



## On Demand Water Pumps - 230v & 110v variants



### Supply pressurised water to toilets, sinks, showers, kitchens and glamping pods

If your construction site, event or glamping location does not have a mains water supply, this on-demand, electric water pump provides pressurised “clean / non-potable” water to toilets, showers, catering units, glamping pods and other facilities.

Designed for clean-water applications, this plug-and-play unit self-primers and draws water from an onsite water storage tank, delivering it to the point of use with consistent pressure. An integrated pump controller automatically starts and stops the pump.

Provided your site can receive water deliveries to a suitable storage tank and you can supply power to the pump, this robust system will deliver up to 100 to 120 litres per minute (depending on the variant).

**THESE UNITS WILL PERFORM BEST WHEN CONNECTED TO A SINGLE TOILET OR SHOWER BLOCK, GLAMPING POD etc.**

**!!! IF IN ANY DOUBT, PLEASE CONSULT US WHEN CONFIGURING COMPLICATED FLOW OR CONNECTION REQUIREMENTS !!!**

### Where are they used?

For off-grid sites where there is no mains water these pumps supply pressurised water from a captive water tank for....

- **Construction sites**  
site offices, toilets, kitchens and showers
- **Outdoor events, shows & festivals**  
VIP toilet blocks, showers and catering stands
- **Glamping sites**  
shepherds' huts, glamping pods, shower blocks
- **Home builds, allotments**

Typical site setup - IBC, pump & protective box



### PLEASE NOTE:

**The achievable flow of water depends on several factors, including:**

- the distance to be pumped
- the internal diameter and material of the pipework used
- any bends in the pipework
- if the pump has to work harder by pumping upwards

**all contributing to friction losses and reducing flow rate.**



## On Demand Water Pumps - How they work

### How they work ↓

- The pump is started when a sink tap (for example) is turned on. The pump controller recognises the pressure within the system has dropped below 1.5 bar.
- The pump controller is more advanced than a standard pressure switch: it manages both flow and pressure:
  - it turns on when the pressure drops below 1.5 bar
  - it turns off when the flow drops below 2 l/min\*.
- Although the 230v and 110v pumps have theoretical performance curves up to a maximum of 120 (230v) & 100 l/min\*(110v) the actual performance is governed by the controller, the distance / height to be pumped, and the material and internal diameter of the pipework.
- Both pumps are most efficient at ca. 60 l/min\*.
- In real terms, even if all 4 toilet cisterns of a 3+1 toilet block are flushed at the same time, the water required to refill the cisterns will be 6 litres per cistern (24 litres) over about 30 seconds - i.e. a flow rate of 48 l/min\*.
- Other typical consumption rates:
  - An electric 7kW shower = ca. 8 l/min\*.
  - A domestic cold tap = ca 4-6 l/min\*.

\* Note: l/min = litres per minute

### The 2 variants ↓

1. 230v version:
  - Pedrollo FUTURE JETm 2A-ST self-priming pump
  - PRESFLO electronic pump controller
2. 110v version:
  - Pedrollo FUTURE JETm 1A-ST self-priming pump
  - EASY PRESS electronic pump controller

Suitable for use with clean water / non-potable\* (see note below) and with liquids that are not chemically aggressive, **FUTURE JET** pumps are self-priming and designed to pump water even where air is present in the system.

The pump controller's electronics protect the pump against unsuitable operating conditions such as:

- dry running
- repeated start-ups (e.g. due to pipework leaks), and
- blockages (due to prolonged idleness).

The controller also includes an emergency stop button.

The 1" brass filter fitted to the pump inlet protects it from any debris which may be present in the water.

Both variants are fitted with a 16amp commando plug to match the pump controller's rating.

\*Note: this pump is not WRAS-approved for potable water

Variant 1: 230v pump with Presflo pump controller



Variant 2: 110v pump with Easy Press® pump controller





## On Demand Water Pumps - typical applications

↓ **Typical application:**  
*from water tank to pump and site cabin / shepherd's hut etc.*

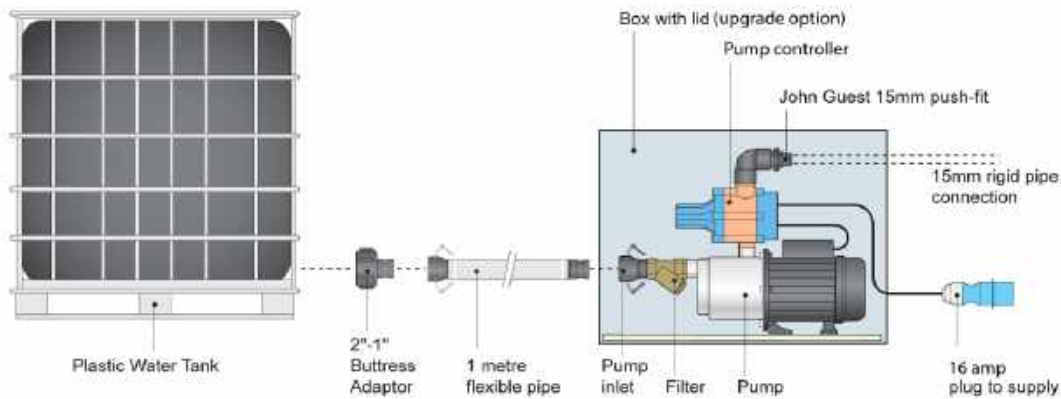

*This graphic depicts the pump connected to a 1000 litre IBC water cube supplying water to a site office or toilet block.*



↓ **Alternative installation:**  
*pumping from below to pump and site cabin / shepherd's hut etc.*

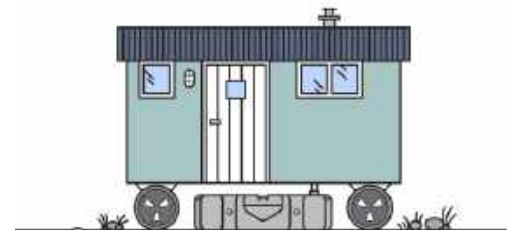
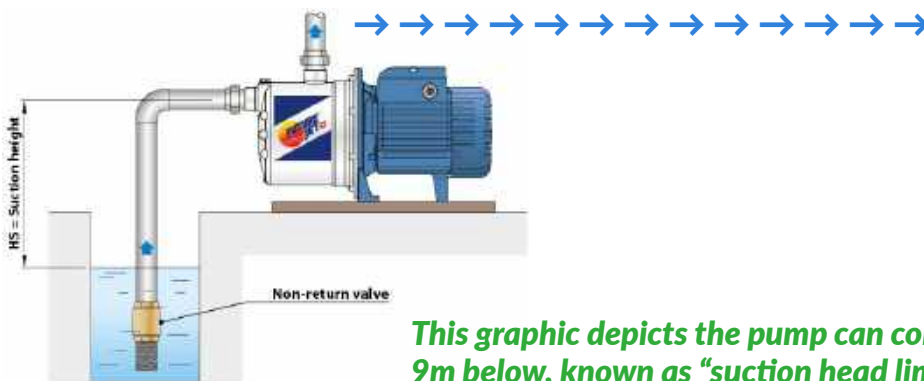

*This graphic depicts the pump can connect to a water source - at up to 9m below, known as "suction head limit" - and then pump water onwards.*



## Key components - on demand water pumps

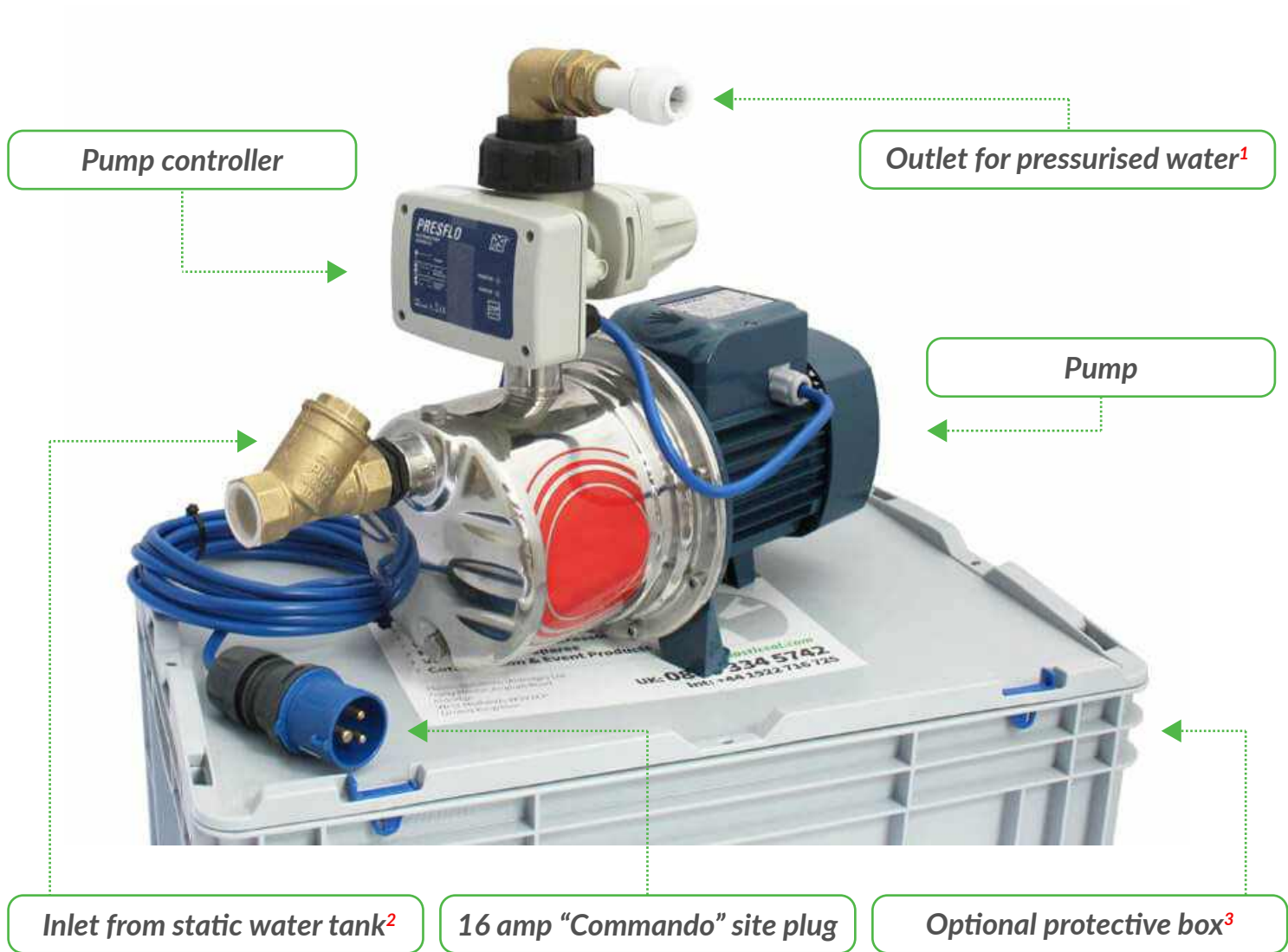

### KEY TO NOTES:

- 1. Outlet for pressurised water from pump to destination**  
Quick-connect fitting for 20mm OD / 15.2mm ID rigid water pipe (plastic or copper).  
This fitting can be removed for customers to use 1" BSP threaded female fitting.
- 2. Inlet from static water tank**  
1" brass inlet with female BSP thread and filter mesh to prevent debris being drawn into pump.
- 3. Optional protective box**  
The FUTURE JET water pump is rated as IPX4 - the box protects the pump from rain / splashing.



# FUTURE JET<sup>m</sup> Water Pump Dimensions

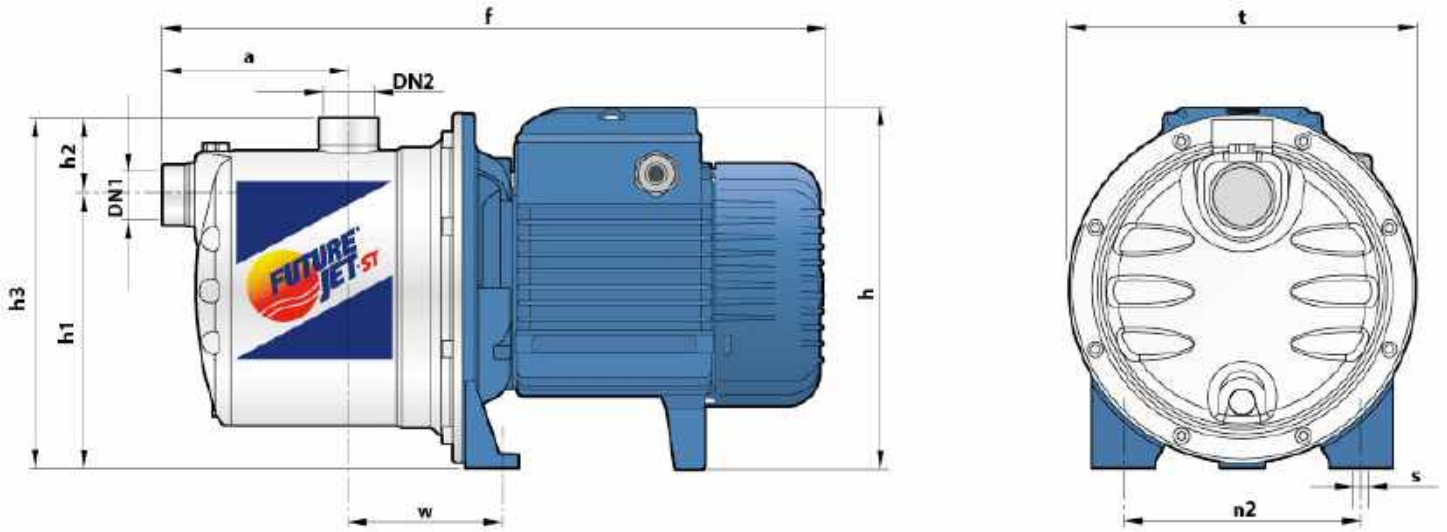

MODEL	PORTS		DIMENSIONS (mm)										Weight (Kg)	FULL MODEL NAME
	DN1	DN2	a	f	h	h1	h2	h3	n2	s	t	w		
<b>230v Pump</b>	1"	1"	111	393	217	162	46	208	142	10	208	91	11.4	FUTURE JET <sup>m</sup> 2A-ST
<b>110v Pump</b>	1"	1"	113	367	183	132	51	183	120	9	182	87	7.4	FUTURE JET <sup>m</sup> 1A-ST

## Flow rate / head / current rating

Data	FUTURE JET <sup>m</sup> 2A-ST	FUTURE JET <sup>m</sup> 1A-ST	Pump Controller
Flow rate	5-120 l/min	5-100 l/min	-
Max. head	58m	48m	-
Max. working pressure	6 bar	6 bar	10 bar
Suction head limit	9m	9m	-
Max liquid temp.	40°C	40°C	55°C
Rated current	6.6 A	4 A	16 A
Max. starts per hour	20	20	-



### THIS PUMP AND PUMP CONTROLLER COMBINATION IS CONFIGURED TO WORK:

- AT UP TO 20 STARTS PER HOUR
- AND IS MOST EFFICIENT PUMPING AT ca. 60 LITRES PER MINUTE (maximum flow is from 100-120 l/min)
- WITH AT LEAST 1 MINUTE BETWEEN STARTS
- TYPICALLY SUPPLYING WATER TO AN ADJACENT TOILET / SHOWER BLOCK / SHEPHERD'S HUT / SITE KITCHEN
- PLEASE CONSULT US IF IN DOUBT AND WHEN CONFIGURING MORE COMPLICATED OR HIGHER VOLUME REQUIREMENTS



## Performance curves - FUTURE JETm Pumps

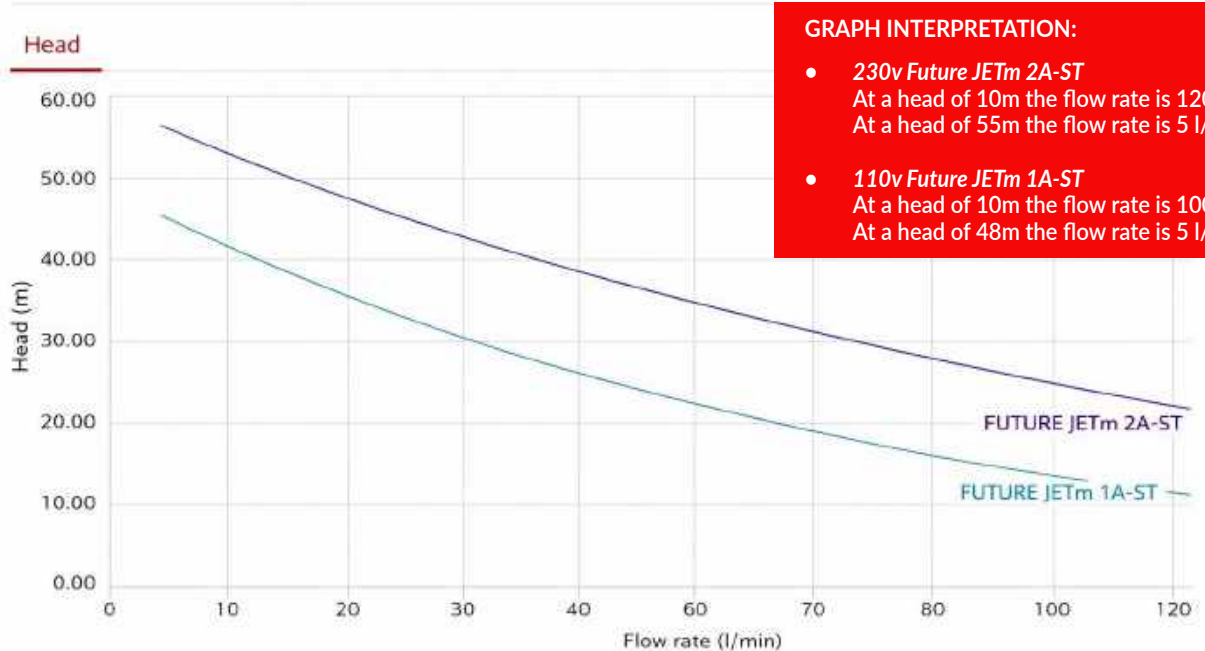

### GRAPH INTERPRETATION:

- 230v Future JETm 2A-ST  
At a head of 10m the flow rate is 120 l/min.  
At a head of 55m the flow rate is 5 l/min.
- 110v Future JETm 1A-ST  
At a head of 10m the flow rate is 100 l/min.  
At a head of 48m the flow rate is 5 l/min.

Impact of head on flow rate

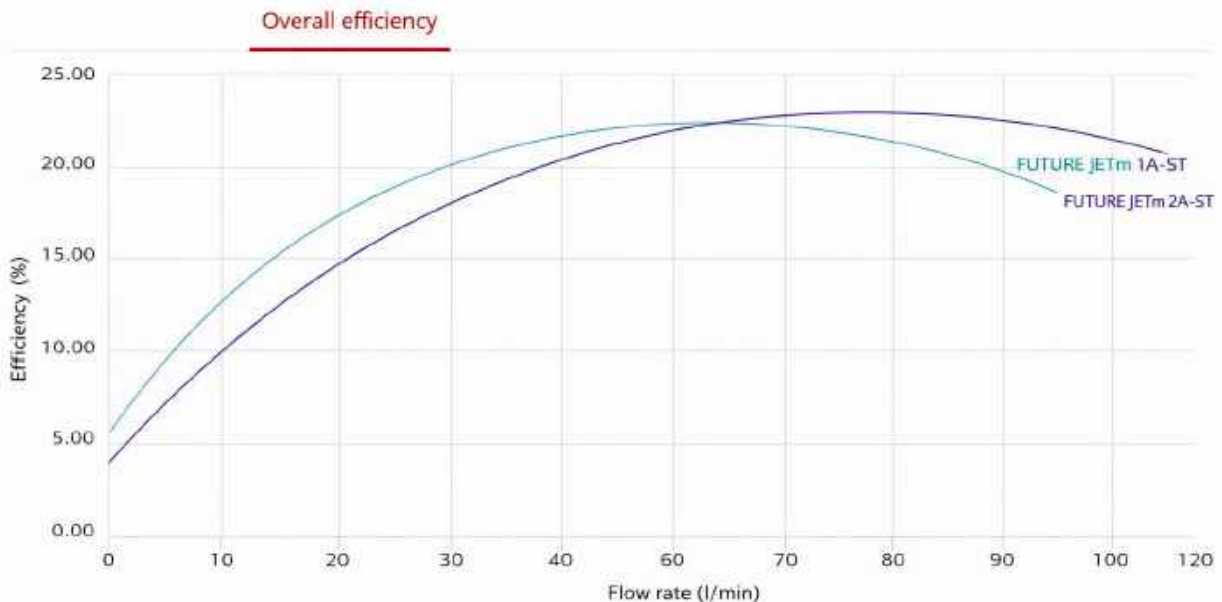

Pumps are at their most efficient in the centre of their performance curves

PLEASE CONSULT US IF IN DOUBT WHEN CONFIGURING COMPLICATED FLOW REQUIREMENTS