

Code	46FJ202AA1
Family	FUTURE JET-ST
Group	Self-priming
Typology	Surface

Extra UE Only	Yes
Uses	Civil Household

Application limits

Liquid Type	Clean Water
Minimum liquid temperature	-10 °C
Maximum liquid temperature	40 °C
Maximum Chlorine Content	- ppm
Maximum Sand Content	- ppm
Manometric suction lift	9 m
Maximum immersion depth	- m
Maximum Ambient Temperature	40.0 °C
Minimum Ambient Temperature	- °C
Maximum Working Pressure	6 bar

Construction and safety standards

- EN 60335-1, IEC 60335-1
- EN 60034-1, IEC 60034-1

Connections

Type of connection	Gas threaded
Size of suction connection	1"
Size of delivery connection	1"

Duty Point

Flow rate (actual)	0.000 l/min
Head (actual)	0.000 m
Overall Efficiency	0.00 %
Motor input power P1	0.00 kW

Input Data

Rated flow rate (requested)	0.000 l/min
Rated head (requested)	0.000 m
System geodetic head	0.000 m
System friction losses	0.000 m
NPSH Available	0.000 m
Liquid	Water
Temperature	20 °C
Density	998.1 kg/m ³
Kinematic Viscosity	1.00 mm ² /s
Vapour Pressure	2,318 Pa

Pump nameplate data

Flow rate	5 - 120 l/min
Head	55 - 13 m
Maximum head	58 m
Minimum head	13 m
Minimum Efficiency Index	-

Motor nameplate data

Voltage	220-230 V
Phases	1
Frequency	50 Hz
Rotation Speed	2900 rpm
Rated output power	1.10 kW
Rated Current	6.6 A
Input power P1	1.45 kW
Efficiency grade	Undefined
Capacitor	25 µF
Capacitor Voltage	450 V
Insulation Class	F
Enclosure class IP	X4

Other Motor Data

Starting/Rated Current	2.833
Max No. Starts Per Hour	20
Service Factor	-
Cos Φ (4/4)	-
Efficiency (4/4)	-
Thermal Protection	Thermally Protected
Plug Type	-
Minimum flow rate for motor cooling	- cm/s
Minimum submersion for S1 duty	- mm

Performance

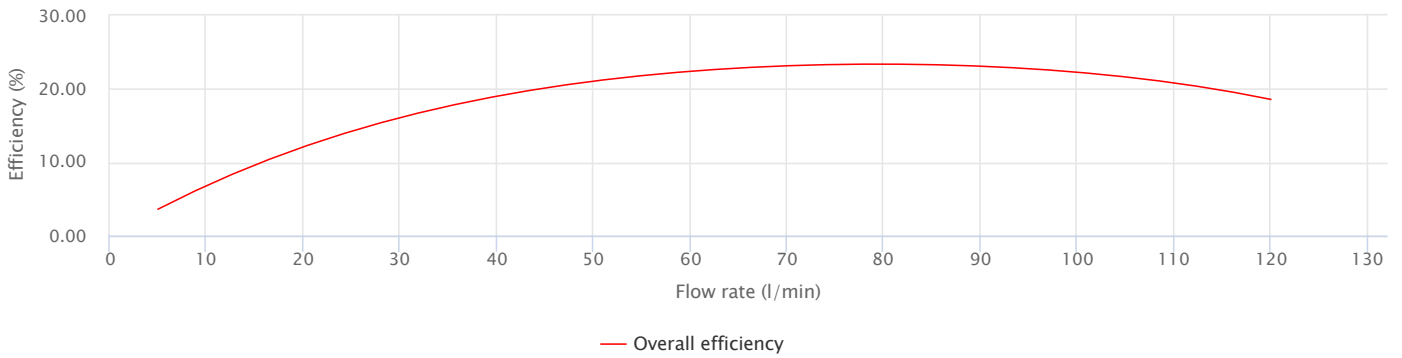
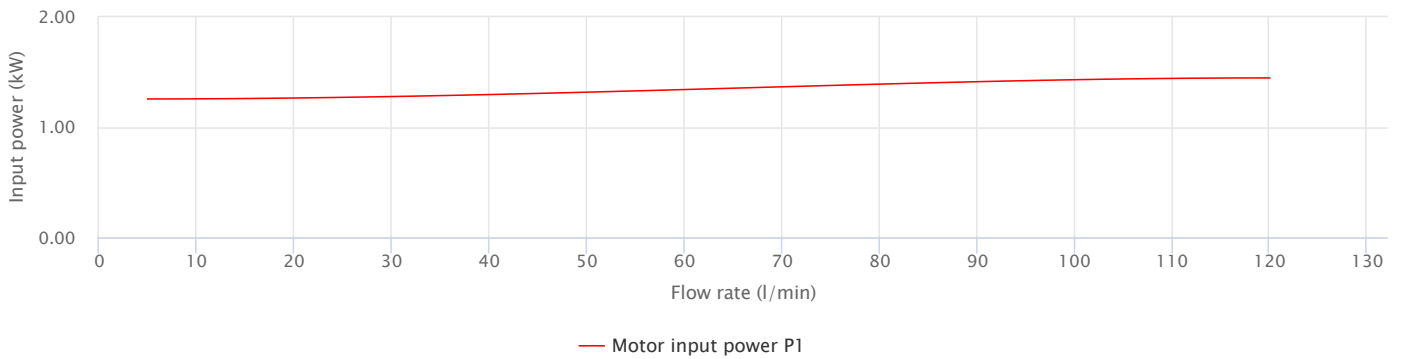
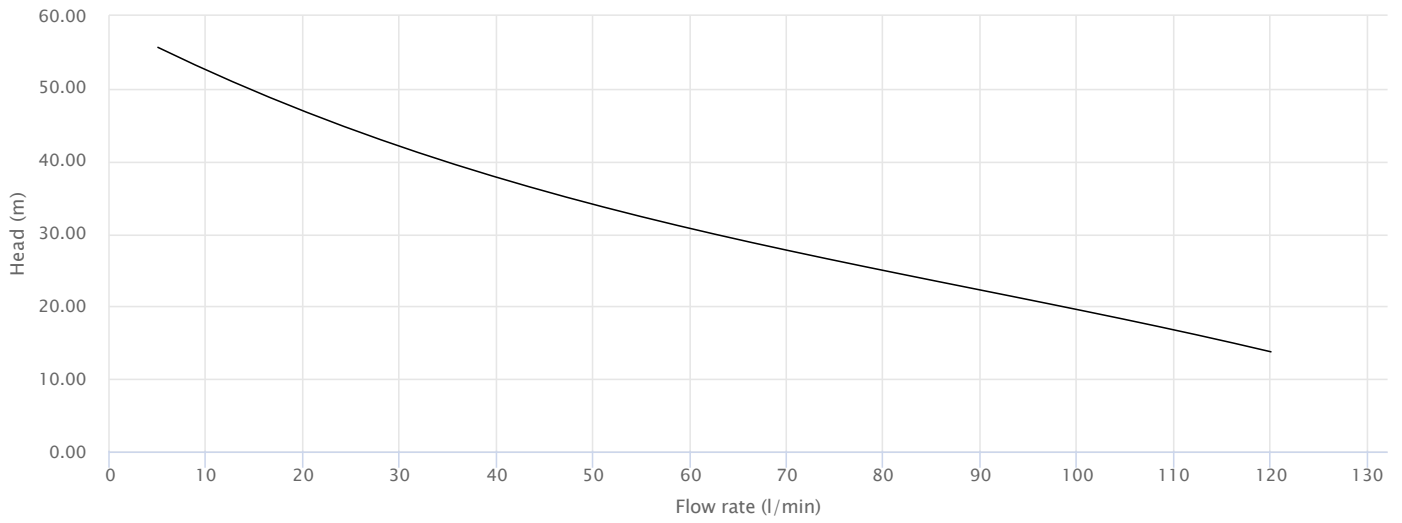

Construction

Bearings

Motor bearing - pump side	6203 ZZ
Motor bearing - opposite side	6203 ZZ

Shaft Seal

Seal Type	Single mechanical seal
Pump Side Model	AR-14
Diameter PS	14
Stationary Ring PS	Ceramic
Rotating Ring PS	Graphite
Elastomer PS	NBR

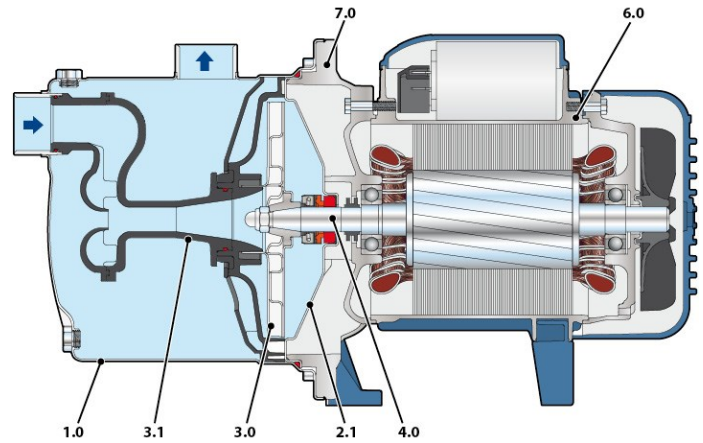

Materials

1.0 - Pump casing	Stainless steel EN 1.4301 (AISI 304)
2.1 - Casing Cover	Stainless steel EN 1.4301 (AISI 304)
3.0 - Impeller	Stainless steel EN 1.4301 (AISI 304)
3.1 - Ejector unit	Reinforced technopolymer
4.0 - Pump Shaft	Stainless steel EN 1.4057 (AISI 431)
6.0 - Motor casing	Die cast Aluminium EN-AB 46100
7.0 - Bracket	Die cast Aluminium EN-AB 46100

Dimensions

DN1	DN2	a	f	h	h1	h2	h3	n2	s	t	w	Kg
[mm]												
1"	1"	111	393	217	162	46	208	142	10	208	91	11.4

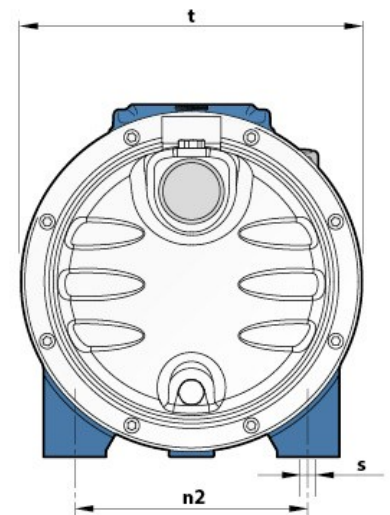
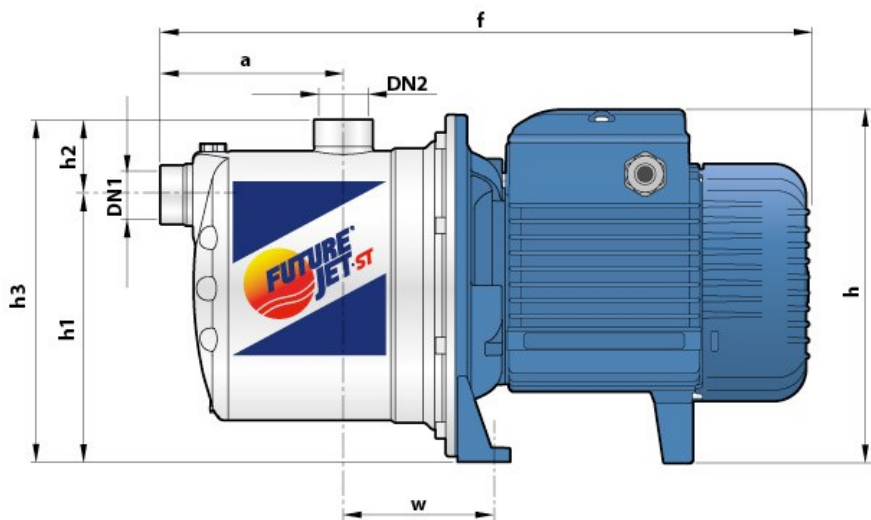

ELECTRONIC PUMP CONTROLLER

PRESFLO® is a device that starts and stops the pump to which it is fitted, thus replacing traditional pressure switch / surge tank systems. The pump is started when, as a tap is turned on, the pressure within the system drops below the "start-up pressure" (Pm), and is stopped when the flow

rate required is zero or less than the "shut-off flow rate" (Qa). PRESFLO®'s electronics protect the pump against unsuitable operating conditions such as dry running or repeated start-ups due to leaks.

PRESFLO



USED WITH PEDROLLO FUTURE JETm 2A-ST 230v PUMP

Technical specifications

- Voltage: ~230 Volt / ~115 Volt
- Frequency: 50-60 Hz
- Current: 10A, max 12A for 3 sec.
- Current: 12A, max 16A for 3 sec.
- Protection grade: IP 65
- Start-up pressure (Pm): 0,8/1,5/2,2 bar (12/22/32 psi)
- Shut-off flow rate (Qa): 2 litres/min (0,5 gpm)
- Connections: 1" BSP / 1" NPT
- Maximum working pressure: 10 bar (145 psi)
- Bursting pressure: 40 bar (580 psi)
- Weight: 650 g
- Protection against:
 - dry running (automatic restart)
 - repeated start-ups
- Max room temperature: 40°C
- Max liquid temperature: 55°C
- Type of drive: 1C
- Max manual operations on push button: 1000
- Max automatic operations on relay: 100000
- Class 3A PTI
- Pollution degree : 2
- Max rated voltage pulse: 2,5 kV
- 230V 12A for EMC test
- Pressure operating differential: 10 bar

Before installing, the product, check that the RATINGS correspond with those required.

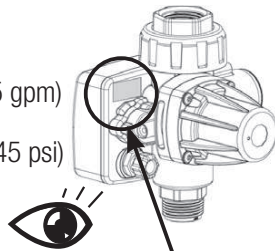

CODE: **50066/115**
 V / Hz: **~230 / 50 - 60**
 I max: **16 A**
 P start: **1.5 Bar**
SN 15060002 **B**

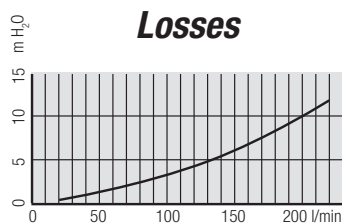

Operating conditions

- A. Compatible/non compatible fluids**
 PRESFLO® is suitable for use with clean water and chemically non-aggressive liquids. If the fluid contains impurities, a filter should be fitted upstream.
- B. Environmental conditions**
 PRESFLO® should not be used where there is the risk of an explosion. The temperature of the location should range between 0°C and 40°C, and the humidity should not exceed 90%.
- C. Power supply**
 Make sure that the variation

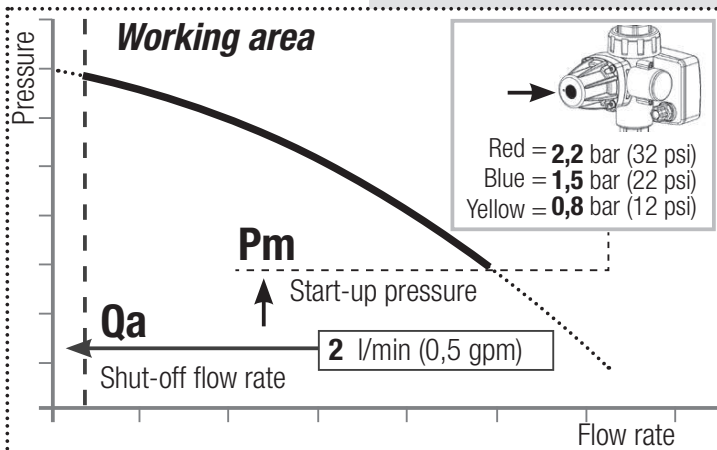

in the power supply is never more or less than 10 % of the RATING value. Higher values may cause

Safety regulations

Before installing or using PRESFLO®, read this manual carefully and thoroughly. The pump should be installed and serviced by qualified personnel, responsible for making the hydraulic and electrical connections in compliance with the relevant regulations. DGFLOW® shall not be held liable for any damage relating to, or resulting from, an improper use of the product, or for any damage relating to, or resulting from, servicing or repairs carried out by unqualified personnel and/or with non-OEM spare parts. The warranty, which is valid for 24 months from the date of purchase, will no longer be applicable should the product suffer damage as a consequence of the use of non-OEM spare parts, tampering or improper use. When starting the installation, check the following:

- the power supply is switched off.
 - the power lines can withstand the maximum current.
 - the cable bushings and circuit board cover have been properly assembled and secured (see Electrical Connections).
 - Power supply network must be fitted with proper protection device (fuse or magneto-thermal relay) upstream of PRESFLO®
- When servicing the product, check the following:
- the system is not pressurised (turn a tap on)
 - the power supply is switched off.
- Emergency Stop**
 When in use, the pump can be stopped in the event of an emergency: press STOP/RESTART.

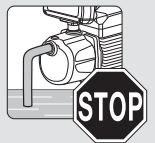

PRESFLO® is put STAND-BY.

Never disassemble water accumulator

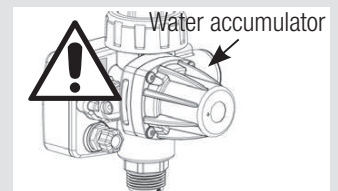

damage to the electronic components. PRESFLO® can only be used with single-phase pumps.

Installation

Preliminary checks

Take the PRESFLO® out of the packaging and check the following:

- check for damage,
- check the RATINGS correspond with those required,
- that the cable bushings and screws are in place,
- that PRESFLO®'s inlets and outlets are clean and free of any packaging materials,
- that the check valve moves smoothly.

Hydraulic connections

the joint in two pieces allows rapid connection to the system. DO NOT apply sealant inside the 2-piece joint because it already has an internal o-ring.

Orientation

PRESFLO® can be installed at any angle depending on the flow direction, as indicated in the diagrams.

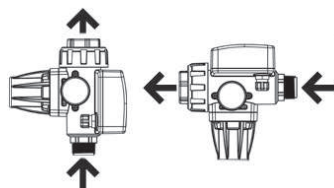

Position

PRESFLO® can either be fitted directly to the pump outlet or anywhere along the delivery line. Never install taps between the pump and PRESFLO®. Do not install a non-return valve between PRESFLO® and the taps, meanwhile it is possible, although not necessary, to install a non-return valve on the suction piping of the pump.

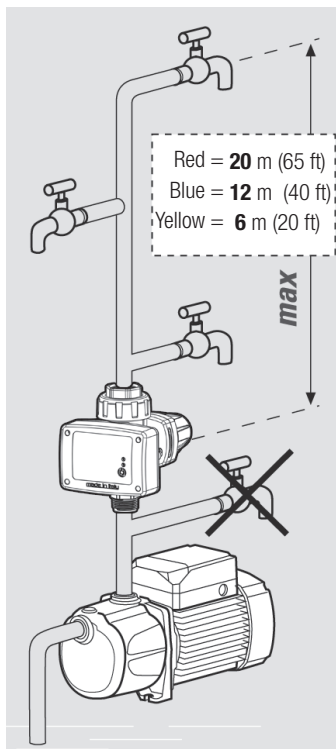

Attention

The pressure applied by the water column above PRESFLO® must not exceed that of the pump start-up pressure (Pm). If, for example, PRESFLO® is installed at a height 15 m (50 ft) below that of the highest tap in the system, the pressure detected by PRESFLO® will be approximately 1.5 bar (22 psi). A model with Pm = 2.2 bar (32 psi) should, therefore, be installed in order to guarantee that the pump is started when a tap is turned on.



Attention

The maximum pressure produced by the pump must be at least 1 bar (15 psi) higher than the start-up pressure (Pm). If the pressure produced by the pump is too low, PRESFLO® will stop the pump and indicate a 'dry running' error message.

Electrical connections

The electrical connections should be made as indicated in the diagram which can also be found on the inside of the circuit cover.

Attention! The cable bushings and circuit board cover must be properly assembled and secured in order to guarantee IP 65 grade protection of the electrical components.

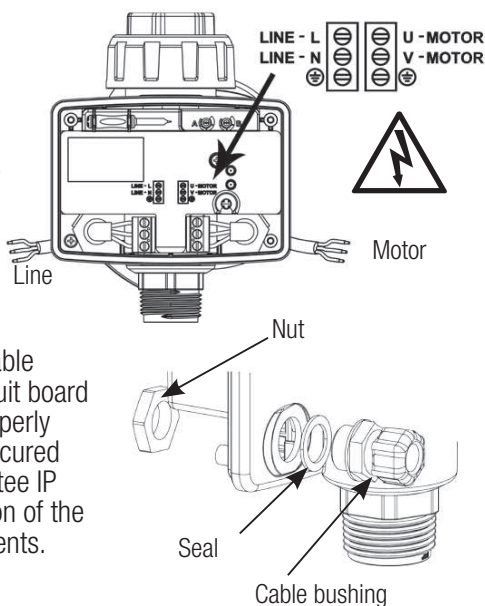

First start-up

Priming the pump

For instructions on how to prime (fill) the pump, see the pump manual.

Attention

PRESFLO® is fitted with a check valve: do not use the PRESFLO®'s outlet to fill the pump for priming.

Switching the pump on

The red (Power On) LED lights up; PRESFLO® instantly detects that there is no pressure within the system and starts the pump (the green 'Pump On' LED lights up).



If, within 15 seconds of starting up, PRESFLO® does not detect the correct priming of the pump, it stops the pump and indicates a 'dry running' error message.



Attention

When the pump is started for the first time, it may have to be run for longer in order to complete the priming procedure.

Press the STOP/RESTART button

to restart the pump and complete the priming procedure.



NOTE 1 - DRY RUN PROTECTION = there is no flow and the pressure is lower than that of the pump start-up pressure (Pm). It occurs when there is no water. After 15 seconds PRESFLO® stops the pump and indicates an ERROR message. PRESFLO® AUTOMATICALLY tries to resume NORMAL SERVICE at intervals of increasing time (1, 15, 30, 60 minutes and successively once every hour - 24 H for AU/NZ -). If PRESFLO® detects any pressure and/or flow, NORMAL SERVICE is resumed, otherwise, the pump is stopped again until the next attempt is made. A MANUAL attempt to resume NORMAL SERVICE can be made at any time.

NOTE 2 - EXCESSIVE STARTS = the repeated stopping and starting of the pump at intervals of less than 1 minute from each other. This occurs when the flow rate is less than 2 litres/min. This may cause damage to the pump. In event of small leaks (dripping),

PRESFLO®'s water accumulator guarantees that the pump starts/stops at time intervals of over 1 minute (less than 60 starts/hour) and that FREQUENT START-UP errors do not occur. In the event of a major leak or extended use at excessively low flow rates (less than 2 litres/min), the pump may be started/stopped as often as once every few seconds, putting the pump at risk of damage. In this case, after about 40 minutes, PRESFLO® stops the pump for the following 30 minutes (in order to let it cool down) and indicates an ERROR message. If the time interval between the starts-stops is more than 10 seconds (and therefore poses less of a risk to the pump), PRESFLO® will allow the pump to be used for more than 30 minutes. Once that enough time has passed to allow the pump to cool down it is restarted AUTOMATICALLY. The pump may be restarted MANUALLY any time.

1 No power supply

POWER ON ○ PRESFLO® is switched off.
PUMP ON ○

Press briefly or hold down = nothing happens

Power is restored = PRESFLO® resumes NORMAL SERVICE and starts the pump (if necessary).

2a NORMAL SERVICE: the pump is inactive.

POWER ON ● The system is pressurised.
PUMP ON ○ All taps are turned off. There is no demand for water.

PRESFLO® detects an assembly pressure higher than that of the start-up pressure (Pm) and no flow.

Press briefly = the pump is started manually and runs for a few seconds before stopping again.

Hold down = the pump is put STAND-BY. For instructions on how to reactivate the pump, see point 3.

A tap is turned on = as soon as the pressure falls below the start-up pressure (Pm), the pump is started.

2b NORMAL SERVICE: the pump is running

POWER ON ● The assembly requires water.
PUMP ON ● One or more taps are turned on. PRESFLO® detects a flow; the assembly pressure is normally higher than the START-UP pressure, but it may also be lower.

Press briefly or hold down = the pump is stopped and put STAND-BY. For instructions on how to reactivate the pump, see point 3.

The taps are turned off = If there is no flow for a few seconds, the pump is stopped.

2c NORMAL SERVICE: pump during shutdown

POWER ON ● The system has just ceased to require water. All taps are closed. The pump is still in operation. The system is pressurised. PRESFLO® detects a system pressure higher than the start-up pressure (Pm) and no flow.

Press briefly or hold down = the pump is stopped and put in STAND-BY. To reset see point 3. If the absence of flow lasts for a few seconds the pump is stopped

3 STAND-BY

POWER ON ⦿ The pump has been stopped manually. The pump will remain inactive until a new command is given.

PUMP ON ○

Press briefly = nothing happens.

Hold down = the pump resumes NORMAL SERVICE. See points 2a - 2b.

4a ERROR: stopped temporarily due to DRY RUNNING

POWER ON ⦿ See NOTE 1) PRESFLO® has detected that the pump is dry running and has therefore stopped it TEMPORARILY.

PUMP ON ⦿

Press briefly = the pump is started and manually and resumes NORMAL SERVICE. See points 2a - 2b.

Hold down = the pump is put STAND-BY. For instructions on how to reactivate the pump, see point 3.

4b ERROR: temporary shut down due to FREQUENT START UP

POWER ON ⦿ (see NOTE 2) PRESFLO® has detected that the pump starting-up too often and has therefore stopped it TEMPORARILY.

PUMP ON ⦿

Press briefly = the pump is started and manually and resumes NORMAL SERVICE. See points 2a - 2b.

Hold down = the pump will not restart and goes OUT OF ORDER. The pump is put STAND-BY. For instructions on how to reactivate the pump, see point 3.

Problems	Signals	Possible causes	Solutions
PRESFLO® will not turn on	POWER ON ○ PUMP ON ○	No power	Check the electrical connections
The pump will not start when a tap is turned on	POWER ON ● PUMP ON ○	PRESFLO® model with an inadequate start-up pressure (Pm) for the chosen application.	Relocate PRESFLO® to another position Install a model with a higher start-up pressure (Pm)
	POWER ON ● PUMP ON ●	Faulty electrical connections or pump out of service	Check the electrical connections and that the pump is working
	POWER ON ☀ PUMP ON ○	PRESFLO® "STAND-BY"	Reset PRESFLO® (See Operation, point 3).
	POWER ON ☀ PUMP ON ☀	PRESFLO® in temporary shut down due to "DRY RUNNING" due to lack of water	Wait for the automatic restart or press START to restart manually (See Operation, point 4a)
		Maximum pump pressure is insufficient	Replace the pump with one with more suitable characteristics Install a model with a lower start-up pressure (Pm)
The pump delivers no or low pressure	POWER ON ● PUMP ON ●	Filters or pipes may be partly blocked	Check the water pipes
		PRESFLO®'s valve will not open completely	Check that the valve is not blocked by any foreign objects and clean if necessary
The pump stops and starts repeatedly	POWER ON ● PUMP ON ○	Leaks within the system (less than the shut-off flow rate Qa)	Check the hydraulic connections and repair any leaks. If a leak cannot be repaired, install an expansion tank
The pump will not stop	POWER ON ● PUMP ON ●	The flow rate is higher than the shut-off flow rate (Qa)	Make sure that all taps are turned off and that there are no leaks within the system
		PRESFLO®'s check valve will not close or is damaged	Check that the valve is not blocked by any foreign objects and clean if necessary

○ = Off ● = On ☀ = Flashing

Exploded view of spare parts

Attention: when ordering spare parts, always state the position n° from the diagram below and the product code number found in the pressure-flow regulator technical data table.

- 1 - Circuit board cover
- 2 - Pressure gauge
- 3 - Circuit board
- 4 - Cable bushings
- 5 - Valve unit
- 6 - two-pieces joint with OR

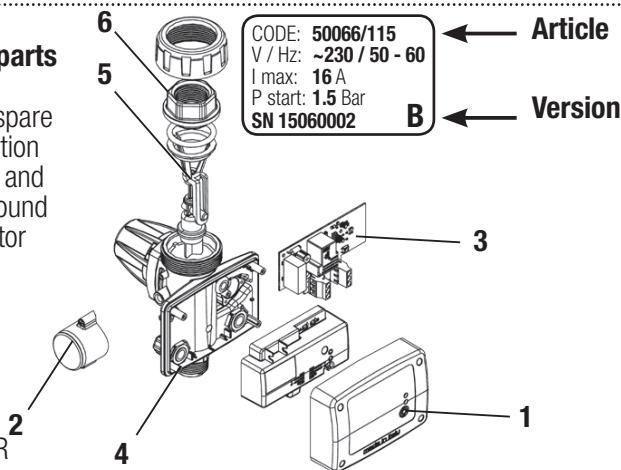

Size

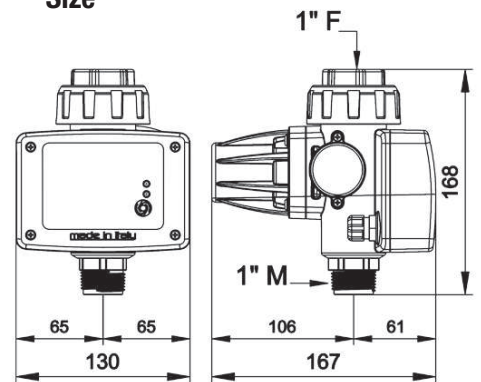

Disposal

When disposing of any PRESFLO® parts, adhere to the relevant laws and regulations in force in the country in which the equipment is being used. Do not dispose of any polluting parts in the environment.



Statement of Compliance: we declare, under our own responsibility, that the product in question is in compliance with the following European Directives and national implementation provisions

2014/35/CE Low Voltage Directive
 2011/65/CE (RoHS)
 2012/19/CE - 2003/108/CEE (WEEE)
 2014/30/CE Electromagnetic Compatibility Directive (EMC)
 EN 60730-2-6
 EN 61000 6-3

Bigarello 01.06.16

DGFLOW S.r.l.
 President
 Stefano Concini

Made in Italy by



DGFLOW srl Via Emilia, 5
 46030 Bigarello (Mantova) Italy
 tel. +39 0376 340922
 fax. +39 0376 249525
 info@dgflow.it - www.dgflow.it