

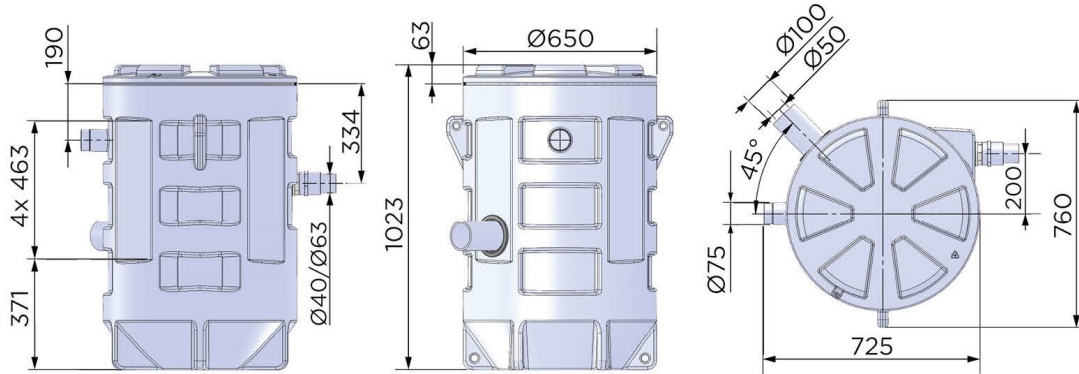

Sewage Lifting Station - Sanifos® 280



DIMENSIONS



Dimensions & Features

Dimensions & Weights	
Tank Volume	280 litres
Overall Dimensions (mm)	1023 H x 696 diameter
Anchor points	2 high level, 2 low level
Dry (empty) weights	Tank = 25 KG, SANIPUMP® = 13 KG
Manhole load bearing capacity	200 KG on an occasional basis Do not install on walkway / vehicle area
Pump on / off level	50% full to 400mm (on) / 100mm (off)

Technical Data

Inlets, Outlets & Ventilation	
Inlet diameters	Ø external 50/100mm to be drilled
Outlet diameters (Grinder)	1 x DN40, Ø external 50mm
Outlet diameters (Vortex)	1 x DN50, Ø external 63mm
Ventilation diameter	1 x Ø external 75mm Vent valve not supplied as standard Install ventilation above flood level
Invert level (FEA)	250-600mm (550-900mm if extended)

Pump details		Notes
Pump type	SANIPUMP® Grinder pump	Submersible sump pump with macerating blades & float switch activation
	SANIPUMP® Vortex pump	Submersible sump pump with vortex action & float switch activation
Motor power / Supply Voltage	1500 W / 220-240 V / 50 Hz	Single phase. Quiet operation with thermal overload protection
Max. current consumption	6A	Consult a qualified electrician for advice / installation
Max. incoming water temp	70° C intermittently (5 mins max)	
Max. flow rate	11 m³/hour (Grinder) 27m³/hour (Vortex)	Performance is dependent on head, pumping distance, pipe bends etc.
Warranty	2 years	Assuming correct installation, pipework and usage within parameters

Hose details		Notes
Rigid pipe for discharge	Smooth bore PVC pressure pipe. Typically sold in 5m lengths, joined with plain PVC fittings.	
Flexible hose for discharge	Smooth bore, flexible PVC hose. Typically sold in 30m lengths, joined with quick-release fittings.	
Installation conditions (take advice)	For domestic applications , comply with buildings regs by installing pipework at least 750mm below ground.	
	If connecting to an existing mains sewer, seek permission from your water authority.	
	For temporary applications , not lived in full-time, generally neither building regs or 750mm depth required (please check).	
Rigid pipe for ventilation	Generally fitted with an air-admittance valve. Ø external 75mm, typically sold in 5m lengths.	



Sewage Lifting Station - Sanifos® 280



Indicative performance*

Vertical/horizontal performance

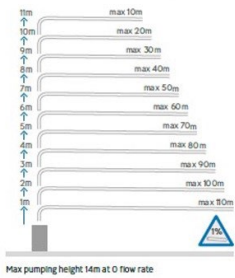

Pump curve*

Discharge H (m)

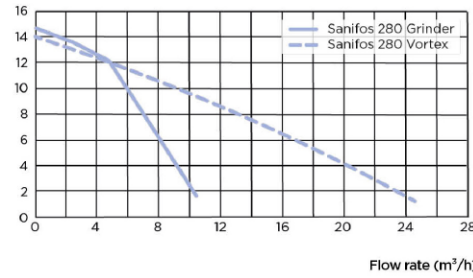

Lifting station accessories



The higher the Sanifos needs to "lift" liquid, so the distance it can pump is reduced. As a very rough guide, for every metre of "lift" required, you will lose 10m of distance pumping.

The higher the Sanifos needs to "lift" liquid, so the pump's flow rate is reduced. If a high flow rate is required, where multiple wastes are created at once, for example, the height Sanifos can "lift" liquid also reduces: it cannot do both high flow and high "lift" concurrently.

Sanifos Alarm - wired alarm unit and float to be fixed in the tank. Warns if liquid inflow is excessive or if pump has failed.
30cm Extension Lid - for deeper installations. Extends inlet level from 250-600mm to 550-900mm

IMPORTANT NOTES:

- * The above charts and these notes are for approximate guidance purposes only. Actual performance may vary depending on the application/site.
- [1] On a technical level, when selecting any Sanifos unit, one should consider several factors including; distance to be pumped; height/head; pipe width (always use correct diameter pipework); pressure; pipe bends; the required flow rate and possible friction losses within the pipework.
- [2] In a long-term, domestic setting (e.g. small dwelling) one should allow for each occupant to generate an average of 150 litres of waste water per day (see note 6). In general, any new plumbing requires building regs. Seek water authority permission to connect into an existing mains sewer.
- [3] In a temporary setting (e.g. glamping pod, shepherd's hut, garden room) one should allow for each occupant to generate an average of 75 litres of waste water per day (see note 6). Temporary installations may fall outside the requirements for planning permission / building regs: please check.
- [4] In all cases, we strongly advise seeking advice on local planning requirements / building regs.
- [5] Only install the equipment as indicated in the official installation manual.
- [6] The waste creation figures listed above (notes 2 and 3) are reproduced courtesy of "British Water's "Flows and Loads 4" (2013 revision).

Equipment provided



Grinder Sanipump® c/w grinder blade



Vortex Sanipump® c/w impeller

Optional "upstream" accessories



2" and 4" Isolation Valves

Installed "upstream" of the Sanifos, prevents liquids flowing into tank during maintenance activities

We reserve the right to amend technical specifications without prior notification.

Contact us for more information