

Solid Edge: Solutions for top ten engineering challenges

White Paper

With respect to 3D design, Solid Edge® software is the best choice for accelerating design in the overall process of bringing products to market. Solid Edge also excels at enabling designers to handle engineering changes in an effort to keep up with rapidly rising customer demands and maximize the re-use of imported 2D and 3D data. This white paper provides an in depth look at how Solid Edge solves top ten engineering challenges.

Answers for industry.

Contents

Executive summary	3
Synchronous technology	4
Better transition and re-use from 2D to 3D.....	7
Complete digital prototyping	8
Advanced sheet metal design.....	10
Optimized for massive assemblies.....	11
Production-proven 2D drafting	12
Integrated design analysis.....	13
Collaboration across the supply chain	14
Transparent design and data management.....	15
Facilitating PLM with Velocity Series	16
Conclusion	17

Executive summary

As companies search for ways to improve their design process, updating their CAD system is a common solution for cutting design time while improving product quality. However, implementing any new software tool comes with a certain level of risk, including dealing with implementation downtimes, functionality that only partially meets design needs, capabilities that fail to support newer design innovations or software that is unable to grow with the company.

Solid Edge from Siemens PLM Software offers designers a proven solution for 3D product development that is easy to implement and learn and is complete with advanced functionality. Solid Edge is the industry's most complete hybrid 2D/3D CAD system that uses synchronous technology. It excels at facilitating accelerated design, faster change and improved re-use of imported data. With superior part and assembly modeling, drafting, transparent data management and built-in finite element analysis, Solid Edge (a core component of the Velocity Series™ portfolio) enables companies to master the growing complexity of product design.

The CAD industry continues to push the envelope, offering better ways to design products. As a result, designers are often left to figure out the best technology for their needs. Some companies test and evaluate 3D CAD systems against known requirements while others make choices based on less empirical methods. This whitepaper helps companies understand how Solid Edge meets the top design requirements of today's manufacturing companies.

In essence, Solid Edge unlocks the secrets of better design by facilitating:

- Synchronous technology
- Better transition and re-use from 2D or 3D
- Complete digital prototyping
- Advanced sheet metal design
- Massive assembly optimization
- Production-proven drafting
- Integrated design analysis
- Collaboration across the entire supply chain
- Transparent design and data management

Synchronous technology

There are primarily two mainstream 3D modeling technologies – history-based or traditional modelers and explicit modeling systems. History-based modelers use a feature-based approach to create and edit a model. In addition, since they generally are dimension-driven, their automated model changes are reliable and predictable. However, achieving any predictability requires much preplanning in order to accommodate unforeseen changes that frequently arise.

Alternatively, there are history-free modeling systems, which are sometimes called explicit modeling systems. These feature-less systems offer little in terms of automated design capabilities with dimensions or relationships. But, they are fast and flexible and can handle a wide variety of changes.

Solid Edge offers a different modeling approach called synchronous technology, which was brought to market in 2008. It delivers the best of both modeling worlds. Solid Edge with synchronous technology provides highly automated features with dimensions that facilitate unbounded flexibility and nearly instant performance. It enables designers to accelerate design, execute the engineering change order process faster and improve the re-use of imported 2D and 3D data. Figure 1 illustrates how synchronous technology combines these positive attributes while providing a wide variety of new capabilities that exceed the bounds of both explicit and history-based modeling.

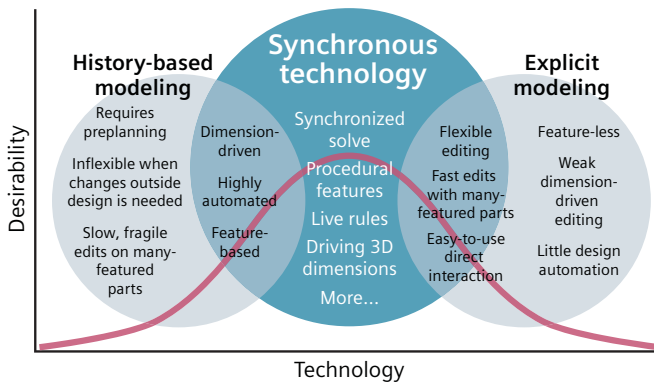
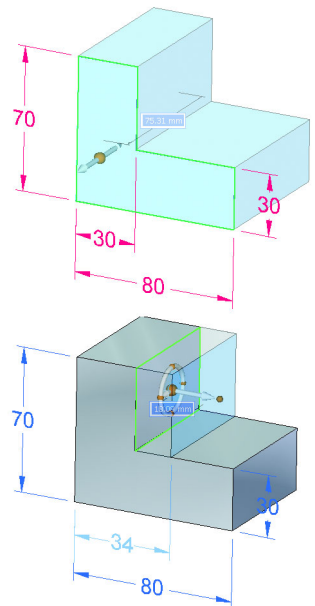

Figure 1. Synchronous technology and how it combines parametric design with explicit modeling for faster construction and change.

Accelerated design

Let's start by showing how design creation can be accelerated with synchronous technology. A unique user interface integrates 2D sketching into the 3D modeling process, where sketches can be dragged into 3D solid shapes. Sketches can be drawn on 3D models by letting users push or pull a cutout or a protruding shape. For precise design, dimensions applied in a 2D sketch automatically propagate to the 3D model, allowing direct modification of the solid. Dimensions can also be added to the 3D model and tied to other dimensions or spreadsheets, or they can simply be locked in place. This process lets designers create models with few or no commands. Parameter-based features such as holes, rounds and patterns can be created using procedural features.

Figure 2. A 2D region (top) is pulled into a 3D shape, and dimensions and intent automatically propagate to the 3D model. Further creation can be done by rotating or pulling faces (lower image). Vertical faces remain constant during the drag even without explicitly defining that rule.



Synchronous technology includes a very unique concept – features are not tied to creation order; this removes the burden of having to plan how future edits are made. During the modeling process, intent is transferred from the sketches to 3D so that designers do not need to “program” how change is managed. For example, as a designer draws concentric cylinders, the matching center points are remembered without having to physically define that condition. Horizontal and vertical faces stay as designed, again without having to build a set of rules to govern that behavior. New users can implement Solid Edge faster to minimize transitional downtimes, while experienced users can speed through modeling faster to accelerate the design process.

Faster change

Faster design is often facilitated by the ability to efficiently deal with planned and unplanned requirements. Because features in synchronous technology are independent of each other, implementing change is much easier and happens much faster. For example, consider Figure 3, where vertical supports need to be rotated. In most cases, users would simply extrude the pillars vertically and remove the interior with a cutout (see the lighter image). Without proper planning ahead of time, this change would require remodeling. Features in synchronous technology can be edited outside the creation order. As a result, designers simply rotate extruded geometry once (see the darker image). Live Rules in Solid Edge automatically recognizes and preserves geometric conditions such as symmetry and tangent blends.

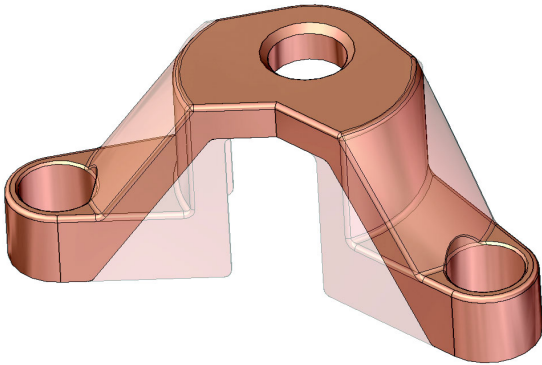

Figure 3. Making a significant change by rotating features initially extruded is easy using synchronous technology. Live Rules recognizes symmetry so an edit can be made to either vertical support.

Edits in synchronous technology only impact related geometry so edit times don't scale with model size. Upon modification, a unique synchronous solve affects the edited features plus any related geometry found via Live Rules. Unrelated features are excluded, thus minimizing solve time. Figure 4 shows the edit performance of synchronous technology compared to a history-based system where unnecessary geometry is updated. Designers can edit what is most important (such as the distance between mounting holes or overall sizes) and get extremely fast performance when making changes.

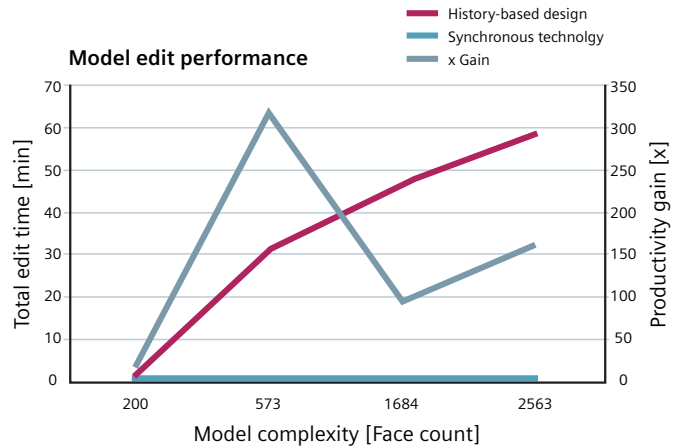

Figure 4. This chart compares performance between edits made in synchronous technology and a typical history-based modeling system. The difference is that synchronous technology edits the minimum amount of geometry, while edits in history-based systems often rebuild the entire model.

More effective re-use of imported data

Synchronous technology also addresses how imported data is handled. Users coming from a 2D system are used to being able to make changes to 2D drawings. But after the move to 3D, designers need to rethink how to handle data supplied in 3D since edits can only be made in the same authoring CAD system. Synchronous technology is different because it can perform many tasks equally as well on imported data – as if the models were in native format.

Constraints that define a model's editing behavior are often lost in translation, but they don't pose an issue for synchronous technology because intent comes from the body. For example, implied relationships (such as faces that are tangent, concentric, orthogonal or symmetric) should probably remain that way. Solid Edge Live Rules capability finds and maintains these geometric conditions during and after the edit. Users can also add 3D driving dimensions directly and tie these together through equations when automated changes are needed. For example, implied that defines the shaft journal for an imported part in Figure 5 needs to be moved (superimposed red faces). The designer simply adds a 3D driving dimension to the center of the hole and keys in the desired value. Live Rules finds the other concentric faces and moves them accordingly.

This same power extends into creating re-usable libraries. Designers can save key geometry in a library but use it later to recreate the shape. Since synchronous technology doesn't require the original features, more flexible geometry-based libraries can be created. With synchronous technology, imported 3D parts can be adapted to meet new uses, helping designers to further cut engineering costs.

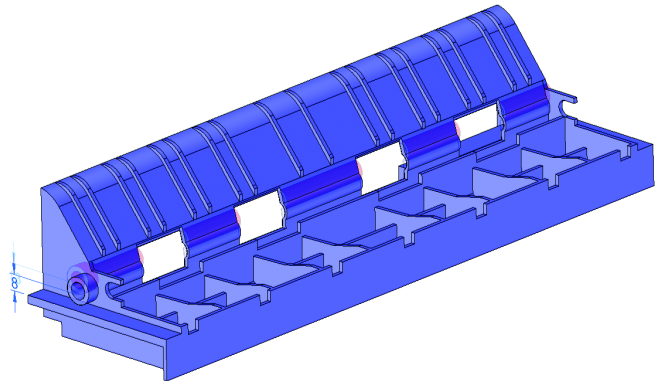

Figure 5. Designers can adapt old parts to new uses with synchronous technology. An edit to an imported part only requires the user to add an editable 3D driving dimension and type in the value. Notice the superimposed results after the edit.

Better transition and re-use from 2D to 3D

Transitioning to any new CAD system is more than just learning the software; it involves leveraging existing data too. Starting with 2D drawings Solid Edge offers a sophisticated 2D import tool that lets designers map drawing entities (such as fonts, color and line styles) with a preview that shows the expected results. Other key 2D elements are retained as well, including model space/paper space and XREF drawings. Opened assembly drawings can be used to drive the fit and position of 3D models; part drawings can be transformed into 3D components with a Create 3D command.

For moving imported 3D data that has a corresponding drawing into Solid Edge, 2D manufacturing dimensions on those drawings can be automatically transferred to the 3D model. Manufacturing dimensions (such as distance between holes and overall height) can be immediately modified and any geometric intent “lost” in translation can be found and maintained with Live Rules.

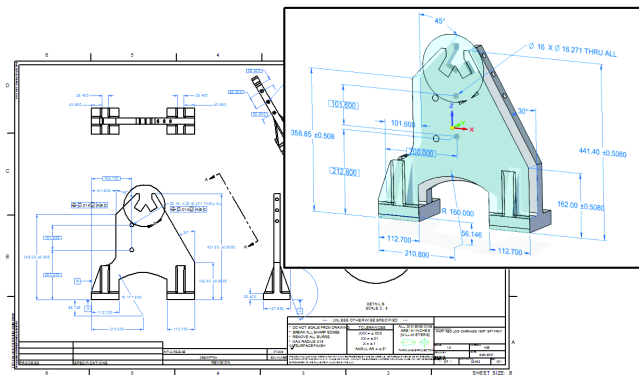

Figure 6. Designers can re-use 2D drawings and 3D parts more effectively with Solid Edge. Manufacturing dimensions of an imported 2D drawing can be automatically applied to its associated 3D model. The results allow designers to edit key parameters, such as distance between holes and overall dimensions.

Opening drawings, parts or assemblies are just the first step; integrating them into existing designs is another powerful capability of Solid Edge. A unique “Zero D” approach lets designers build assemblies (by outlining the assembly structure with a series of virtual or existing components) and

optionally use an assembly layout drawing as a guide. Once complete, the structure can be published into a physical assembly ready for modeling.

Adapting parts or assemblies for new uses can be as simple as a fence stretch and drag using dimensions for precise modification or snapping to key points for an exact match to other parts. Sketch-based edits using Live Sections allow changes to cross sections cut through any part of the model. Transitioning from 2D to 3D involves both a data migration pathway and efficient methods to integrate that data into existing designs – which Solid Edge delivers.

When moving entire 3D projects, the bulk data migration tool in Solid Edge eases import of parts, assemblies and drawings created in SolidWorks, Autodesk Inventor, Pro/E, Autodesk Mechanical Desktop and Siemens NX™ I-deas™ software. This utility retains key design intelligence such as assembly constraints, hole features, pattern recognition, part materials, alternate positions and more, promoting increased re-use of existing data.

Figure 7. Designers can re-use assembly layouts and models more effectively with Solid Edge. Assembly edits across imported and native parts are done with a simple selected fence and drag. This is a familiar process for designers migrating from a 2D system. (Food mixing assembly courtesy of AMF Canada)

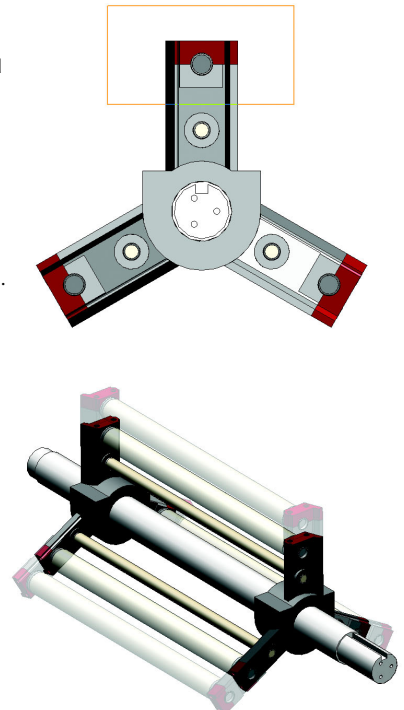

Complete digital prototyping

It is extremely important that a 3D CAD system provide sufficient functionality so that designers can accurately model products before production. Digital prototypes provide numerous benefits such as accurate BOM reporting, part-to-part interference resolution, visualization and the ability to automatically create accurate drawings. Solid Edge enables designers to model all types of products using a highly organized process-specific modeling environment. For example, photorealistic rendering commands are not normally displayed during drawing production (Figure 8).

In Solid Edge, digital prototyping can begin with an assembly using a top-down approach where parts are designed using other components as a guide that ensures fit and position. Alternatively, digital prototyping can begin on a bottom-up basis, where parts are designed outside the assembly and positioned in the assembly later. The latter approach is best used when adding existing parts or imported models from customers or suppliers.

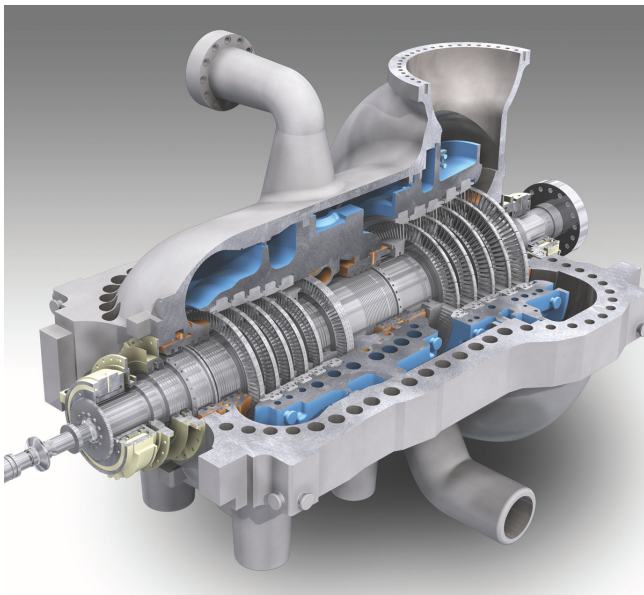

Figure 8. This HIP turbine assembly was modeled in Solid Edge and rendered with its advanced photorealistic rendering application. Material and lighting libraries let designers create life-like product images for customer presentations or promotional activities. (Image courtesy of POMIT Co., LTD, Korea)

Solid Edge has all of the tools needed to create parts for any manufacturing process including processes with machined, casting, plastic injected and sheet metal components. Assembly applications for designing pipes, tubes, structural frames and wire harnesses name the most popular modules. Figure 9 shows an assembly created in Solid Edge that consists of a collection of sheet metal parts for guards, frame components for the main structure, tubing for fuel lines and wiring harness for the electrical connections.

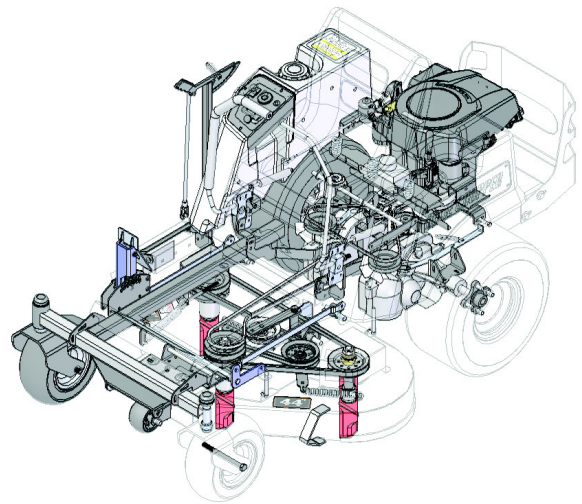

Figure 9. Solid Edge can produce a complete digital prototype complete with sheet metal, machined and supplier components as well as frames, wiring, and tubing designs. (Model image courtesy of the Magic Circle Corporation)

A major requirement of digital prototyping is being able to refine designs quickly. Key edit methods available in synchronous technology help designers make modifications to parts or assemblies. In Figure 10, an interference was found between two parts as shown in red in the top image: editable Live Sections were inserted (center image) and dimensions edited to resolve the conflict (lower image). Other edit methods include adding 3D driving dimensions to a completed part by changing key parameters or by directly pushing, pulling or rotating faces. Live Rules automatically finds and maintains model intent.

Developing digital prototypes also requires fast efficient methods to define and manage alternative configurations. Table-driven part and assembly configurations are available to let designers build siblings and manage parts lists on drawings. Designers can show assemblies in exploded view

or alternate positions. Other capabilities are available to complete the Solid Edge digital prototyping solution, including photorealistic renderings and animations that can be used to enhance design communications without having to build a prototype first.

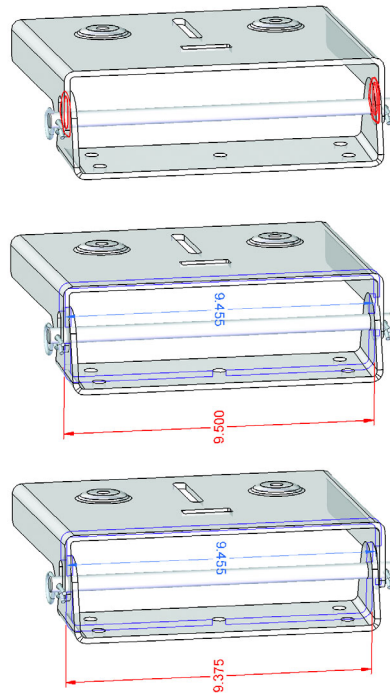

Figure 10. Finding interferences is automatic in Solid Edge. Resolution can be as simple as editing inserted cross sections to size.

Advanced sheet metal design

For sheet metal part modeling, users can develop parts that are manufactured with straight brake, roll, stamp or punch operations. A full complement of features is available to create base shapes, flanges and cutouts, as well as options to create water-tight corners. Punched features can also be added including beads, dimples, drawn cutouts and louvers. Create stamped features by embossing a target part with a tool body. Using synchronous technology, operations such as tabs and flanges can be dragged from existing geometry to greatly reduce command usage.

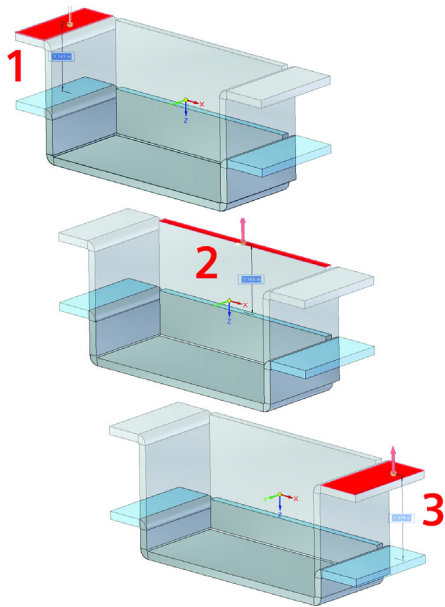

Figure 11. Regardless of how the part was created, designers can edit in the most convenient way. Live Rules keeps designers from creating complex design rules as geometric relationships are found and kept automatically. The top-most faces are flush and should remain so during and after the edit to any of those faces.

Synchronous technology also enhances the editing process by freeing designers to make unplanned changes as needed. The sheet metal cover in Figure 11 could have been created any number of ways, but the designer is not restricted to make edits with that same approach. Flange (1), edge (2) or flange (3) can be moved by a drag or dimension and the others follow along. Because those outer faces are flush, keeping that intent is automatically preserved by Live Rules.

During design, the placement of flanges, cutouts or other features can be validated to ensure manufacturing. Flanges placed too close in proximity may not fit in a press brake – so Solid Edge alerts users to potential issues. Flat patterns can be created from the 3D model and sent directly to manufacturing or added to drawings complete with bend lines, bending sequence tables and all bend details. Also flat pattern sizes can be automatically monitored so they do not exceed blank sheet sizes. Users can create, validate and manufacture sheet parts faster with Solid Edge.

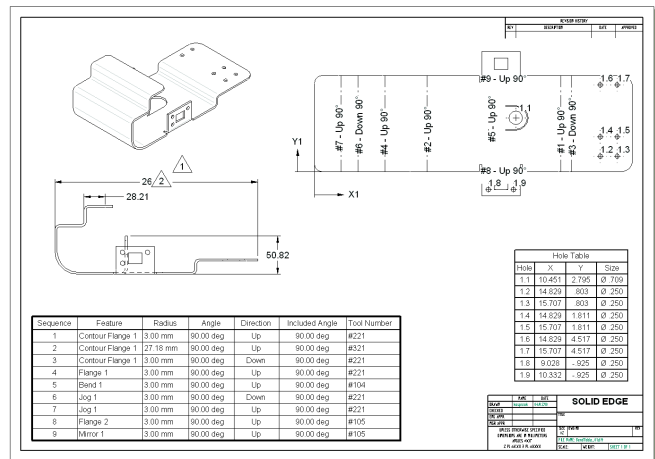

Figure 12. Solid Edge can produce sheet metal drawings complete with folded and flat views. A bending sequence table and a hole table take the risk out of part manufacturing. Bend lines on the folded view can include bend information such as sequence number, direction and angle.

Optimized for massive assemblies

Effective assembly design requires a complete set of tools to manage display data and design areas, as well as a system architecture that is able to handle massive amounts of data. Solid Edge offers a wide range of display management tools. It can support assembly designs of 1 to over 500,000 parts. One of the most important aspects of assembly design is managing display data. Designers must be able to show and hide parts based on type, location and even part size. Solid Edge includes options to show parts based on these conditions, as well as options to show only the selected part or an envelope of parts to quickly identify a subset of data.

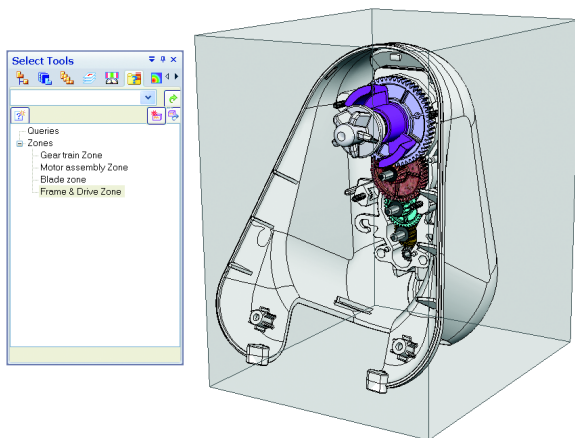
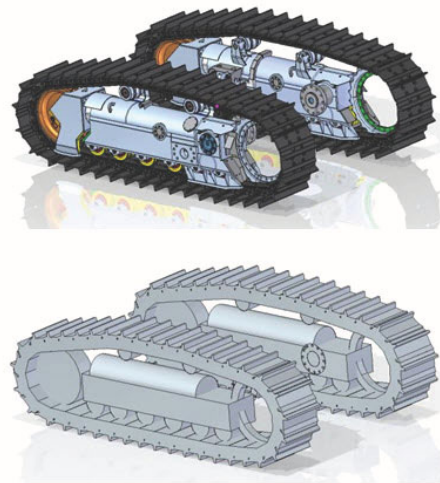

Figure 13. Zones in Solid Edge manage parts display by their physical location, where parts are automatically shown or hidden depending on their proximity to the active zone. Alternatively, display configurations (not shown) manage part display based on the physical part name – users can show all bearings regardless of where they are. (Drive assembly courtesy of SEB France)

Other options let users show just the visible parts while automatically hiding hidden parts – again a smart way to cull the display of unnecessary components. Design zones can be established to control the display data of given regions. These zones let engineers show and focus on specific areas of a model while automatically displaying any new parts that intersect with that zone. Designers can further refine the representation of large assemblies by representing selected components with simple geometric shapes. The resulting shape is associative to the components, and can be modified

to reveal only important external details. This functionality is especially valuable for original equipment manufacturers (OEMs) and suppliers who need to remove proprietary data from assemblies prior to sending the models to final product manufacturers.



Performance is a key part of effective assembly design, encompassing several areas such as display performance, file open times and system performance with large parts counts. Several Solid Edge options are available to optimize display performance. For example, small parts can be automatically culled from display during panning and rotating – which speeds up performance but keeps large parts in view.

An innovative method to reduce memory consumption lets users open files but load only the display and property data, not the underlying geometry. Loading just this data speeds open times and keeps memory usage to a minimum. Should a modeling operation be needed, the geometry can be loaded then unloaded afterwards.

When designers need to work with larger models, a 64-bit version is available that allows for more installed memory. With these display management options, Solid Edge helps designers create and manage all assemblies, including assemblies with over 500,000 parts.

Production-proven 2D drafting

2D drawings are the final deliverable for many engineering processes. Many 3D CAD systems automate 2D drawing production from the 3D model; however, different systems have different features. Solid Edge includes all pertinent comments to make drawing production easier, including capabilities that facilitate easier creation, detailing, updating and routine 2D work. Starting with drawing creation, Solid Edge supports automated development of all view types including orthogonal, isometric, detail, auxiliary, section and other views that enable each view to be shown with or without hidden lines or shading.

To expedite the process, drawings can be created using QuickSheet templates that automatically populate a drawing with predefined standards such as views, parts lists and annotations. Detailing drawing views can be automated by retrieving part or assembly dimensions; a full complement of dimensions and annotation commands are also available. Parts with multiple holes can be easily documented in hole tables, where a table and associated hole callouts are added with a few mouse clicks.

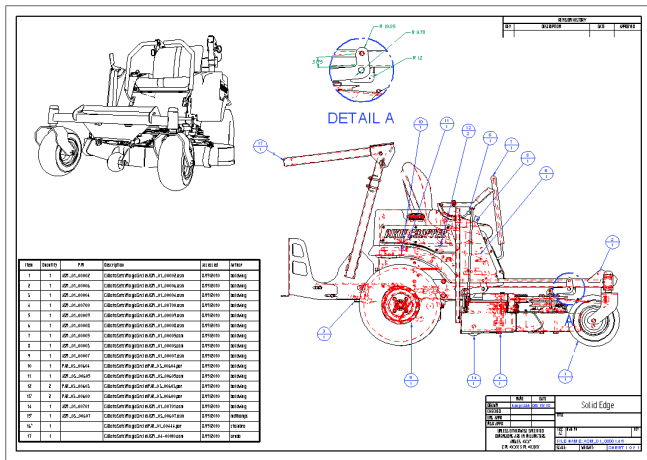

Figure 14. Assembly drawings in Solid Edge can be created with QuickSheet templates where drawing views, parts lists and item ballooning are created automatically. Full dimension and annotations let designers create production-ready drawings with minimal effort. (Model image courtesy of the Magic Circle Corporation)

Documenting the manufacturing of sheet metal parts can be done with bend sequence tables where bend centerlines list the bend sequence, angle and direction. Parts lists with automatic ballooning can be added to assembly drawings, where the list is an exact match of the parts in the model – even for nonphysical parts such as paint. As changes are made to the 3D model, a graphical indication alerts designers when drawing views are out of date, while a build-in tool alerts the user to what changes were made. This provides a perfect tool for automating changes in revision tables.

In certain instances, users will need to create 2D drawings such as assembly layouts or schematics. Solid Edge includes all drawing tools needed to support existing drawings, as well as tools for developing new drawings. Various formats including DXF and DWG (as well as native Solid Edge DFT formats) can be opened; critical details such as layers, colors and fonts are retained. Continued drawing or detailing is supported with a full complement of 2D-specific commands.

Solid Edge provides a set of 2D blocks for creating schematic drawings with electrical, mechanical and piping symbols. For representing wires and pipes, designers can employ specialized commands to create connectors between symbols complete with options to show jumps for intersecting elements. These intelligent connections track with moves to their connected blocks. Designers can start the process of maintaining existing drawings or creating new ones by using Solid Edge 2D Drafting, a free download.

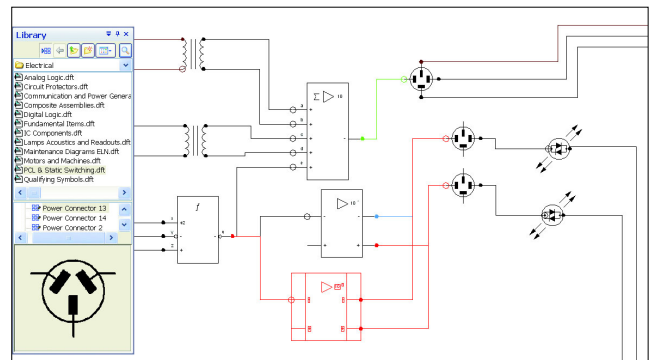

Figure 15. Schematic drawings can be easily created in Solid Edge. Deliverables include symbols for electrical, mechanical and piping that can be tied together with connectors. The above drawing indicates how elements update as blocks are moved.

Integrated design analysis

Simulating product operation involves more than just finite element analysis (FEA). Designers also need the right tools to build parts based on engineering rules, as well as to solve fit and position problems before design and to understand product operation during modeling.

When designing common parts such as shafts, cams, beams and columns, there are standard engineering rules that govern their design. Solid Edge provides a built-in Engineering Reference tool that assists this process. Designers enter key parameters such as speed or torque and the system creates the part of the appropriate size. Optimizing part fit and function while minimizing material costs is crucial in product development. Goal Seek functionality lets designers define complex problems with 2D freebody diagrams or 3D models to solve unknown position or size parameters, or predefined physical property target values.

Figure 16. Part size or physical properties can be optimized with Goal Seek. The designer specifies a constant parameter and the system solves for a variable to maintain the constant.

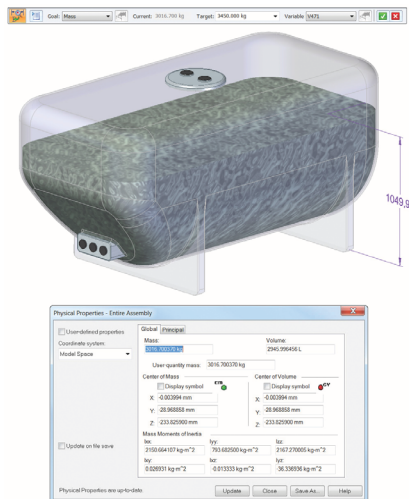

The example in Figure 16 shows a portable tank containing a set volume of fluid. Goal Seek will automatically optimize the height of this fluid off the floor based on that defined volume.

In Solid Edge designers can use motion simulation to understand how moving parts will interact and interference checking to find part collisions. For a detailed analysis on how parts deflect or deform, a complete finite element analysis can be performed. Starting with part analysis, the Solid Edge Simulation Express solution provides quick results as to how parts deform when subject to external forces or what the natural frequencies are in parts that are subject to movement. In this application, meshing and solving are automatic with a level of control to refine the level of accuracy.

For analyzing the performance of parts and assemblies under more realistic situations, Solid Edge Simulation is the application of choice. Designers and engineers can perform studies influenced by structural and thermal boundary conditions (such as bearing loads, torque, bolted parts, convection, conduction and radiation, or where advanced meshing is needed). Optimization functionality helps designers minimize material costs by defining what-if scenarios predicting how a part will react to specified loading conditions while one or more independent variables are iterated over a range of values.

Model simplification can speed up results by temporarily removing insignificant features such as rounds and small holes. Should the results reveal a design issue, refinements can be made using synchronous technology. Designers can add dimensions directly to the model and make changes in order to test design alternatives. This fluid process lets designers test more ideas in less time. When complete system studies are needed, Solid Edge models can be brought into Siemens PLM Software's Femap™ software for advanced analysis. These integrated design analysis tools reduce the need to build physical prototypes.

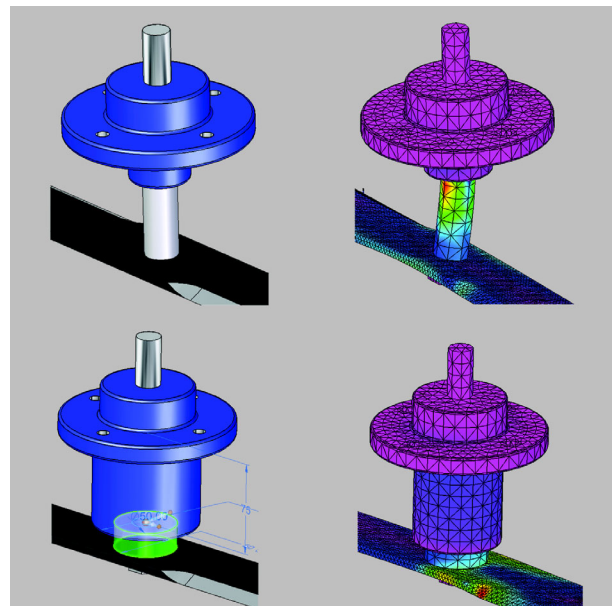

Figure 17. A Solid Edge assembly is analyzed and excessive deflections were found (upper right). A quick design modification using synchronous technology (lower left) solves the problem (lower right).

Collaboration across the supply chain

Designers need to communicate ideas, requirements and concepts across their own operations as well as to outside customers and suppliers. Solid Edge provides sophisticated tools for authoring, distributing, managing and concept testing to help users collaborate more effectively. Starting with documenting designs, users can annotate 2D and 3D models directly with dimensions, annotations and notes, and then package them into a compact package collaboration file (PCF) for easy emailing. Since 3D files are converted to a lightweight JT™ format, this process can be used for handling large amounts of CAD data. Because PCF files are small, distribution can be facilitated with a simple email. Package files can also contain drawings, requirements documents, spreadsheets and images.

Users receiving PCFs can review, measure and redline drawings and parts and leverage Teamcenter® software or Solid Edge SP design management solution to track any added comments. Users can review notes of suggested changes and test design alternatives much easier using synchronous technology. When design ideas need to be shared and explored, Solid Edge gives you the right tools.

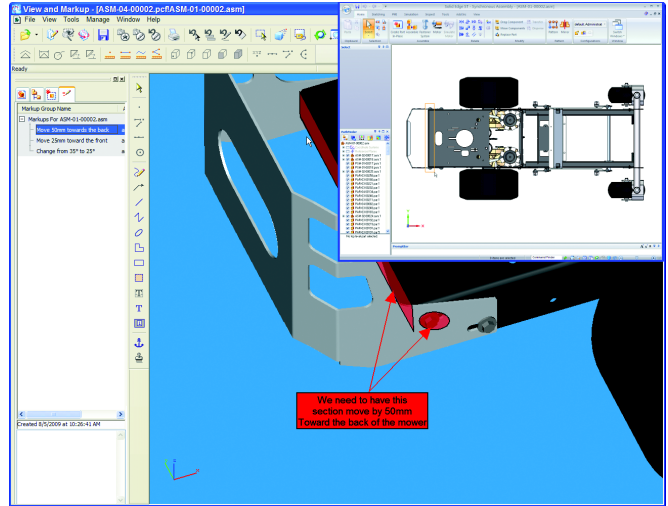

Figure 18. Design changes can be authored in a view and markup application. XpresReview, a free download, lets other users view and redline suggestions. Back in Solid Edge, the modification can be implemented with a simple fence stretch (inset).

Transparent design and data management

One of the most important aspects of any design process is the ability to manage growing volumes of design data, both CAD files and related documents. For effective management, system capabilities need to be built into the CAD file operations so designers don't risk creating unmanaged data. If correctly integrated, transparent product data management (PDM) operations free designers from having to learn separate systems or manipulate files with different commands.

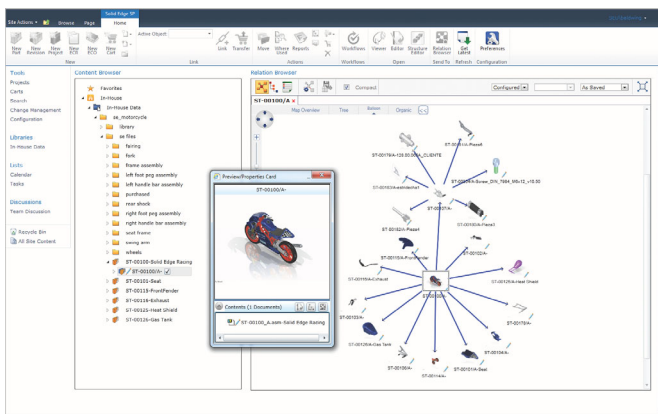

Figure 19. Solid Edge SP is a design management solution that leverages Microsoft® SharePoint® to provide easy vaulting and retrieval of Solid Edge files and related design data, together with a visual approach to managing linked documents, product structures and projects.

Solid Edge provides scalable data management solutions that meet specific customer needs, while enabling design processes to grow as more complex business requirements arise. The Solid Edge SP design management solution based on Microsoft SharePoint provides easy vaulting and retrieval of Solid Edge files and related design data, together with a visual approach to managing linked documents, product structures and projects. With Solid Edge SP, design data can be associated with projects and collection carts providing simple and flexible ways to manage complex data. Solid Edge SP also includes out-of-the-box support for engineering change request (ECR) and engineering change order (ECO) management for fast and consistent completion of these critical engineering tasks. The Relation Browser in Solid Edge SP dynamically displays all the data associated with projects, ECRs and ECOs, so the impact of proposed changes is clear to all. SharePoint also helps to facilitate design collaboration, project management and business-level reporting functions.

For managing wider engineering processes, Teamcenter Rapid Start configuration can be deployed. This collaborative product data management (cPDM) system provides users with a preconfigured, easy-to-deploy and easy-to-use product data management solution they can use to manage data and collaborate across multiple departments, sites and design systems. For managing wider engineering processes, Teamcenter Rapid Start configuration can be deployed for a complete PLM solution that can be customized to meet any need. This is especially appropriate for growing companies with complex requirements. These solutions are completely integrated into Solid Edge, giving users a streamlined approach for managing both data and processes.

Facilitating PLM with Velocity Series

Managing a complete product lifecycle can only be done with integrated products. To help customers achieve maximum productivity, Siemens PLM Software offers the Velocity Series™ portfolio, a comprehensive family of modular, yet integrated solutions that leverage the industry's best practices for ease-of-use and solution deployment.

All Velocity Series products are completely scalable to the full range of Siemens PLM Software's solution portfolio. Understanding that not all companies are the same, Velocity Series products can be purchased on a standalone basis or in an integrated suite. This cost-effective portfolio provides manufacturing companies with a low total cost-of-ownership while ensuring that they are able to realize a dramatic return on their investment.

The Velocity Series portfolio includes:

- Solid Edge – an advanced 3D design suite that simplifies product development while facilitating unprecedented productivity
- Femap – a high performance simulation system that significantly reduces physical testing while speeding time-to-market
- CAM Express – a flexible NC programming solution that improves machining productivity
- Teamcenter Rapid Start – an easy-to-implement collaborative data management system that drives faster project completion

Conclusion

When it comes to 3D design, Solid Edge is the designer's best choice for accelerating design, getting products to market quicker, speeding ECO execution to meet customer demands, and maximizing the re-use of imported 2D and 3D data to cut engineering costs. With superior part and assembly modeling, drafting, transparent data management and built-in finite element analysis, Solid Edge provides the fastest, most flexible design experience possible while easing the growing complexity of product development.

Siemens Industry Software

Headquarters

Granite Park One
5800 Granite Parkway
Suite 600
Plano, TX 75024
USA
+1 972 987 3000

Americas

Granite Park One
5800 Granite Parkway
Suite 600
Plano, TX 75024
USA
+1 314 264 8287

Europe

Stephenson House
Sir William Siemens Square
Frimley, Camberley
Surrey, GU16 8QD
+44 (0) 1276 413200

Asia-Pacific

Suites 4301-4302, 43/F
AIA Kowloon Tower, Landmark East
100 How Ming Street
Kwun Tong, Kowloon
Hong Kong
+852 2230 3308

www.siemens.com/plm

Siemens and the Siemens logo are registered trademarks of Siemens AG. D-Cubed, Femap, Geolus, GO PLM, I-deas, Insight, JT, NX, Parasolid, Solid Edge, Teamcenter, Tecnomatix and Velocity Series are trademarks or registered trademarks of Siemens Product Lifecycle Management Software Inc. or its subsidiaries in the United States and in other countries. All other logos, trademarks, registered trademarks or service marks used herein are the property of their respective holders.

© 2013 Siemens Product Lifecycle Management Software Inc.

Y5 14280 5/13 C

About Siemens PLM Software

Siemens PLM Software, a business unit of the Siemens Industry Automation Division, is a leading global provider of product lifecycle management (PLM) software and services with seven million licensed seats and more than 71,000 customers worldwide. Headquartered in Plano, Texas, Siemens PLM Software works collaboratively with companies to deliver open solutions that help them turn more ideas into successful products. For more information on Siemens PLM Software products and services, visit www.siemens.com/plm.