



---

# Mini-Tx UHD

## Product Manual

Revision B

---

**NORTH AMERICA**  
Broadcast Sports International,  
7455 Race Road  
Hanover, MD 21076  
United States  
Tel: +1-410-564-2600  
Email: [BSI.SALES@BSINTL.COM](mailto:BSI.SALES@BSINTL.COM)

**INTERNATIONAL**  
Broadcast Sports International,  
Axis 3, Rhodes Way  
Watford, Hertfordshire WD24 4YW  
United Kingdom  
Tel: +44 (0)1923 233406  
Email: [BSI.INTLSALES@BSINTL.COM](mailto:BSI.INTLSALES@BSINTL.COM)

Manual part number: 13489-1-000



Revision B

Copyright © 2021, Broadcast Sports International. All Rights Reserved.

This publication or parts thereof may not be reproduced in any form, by any method, for any purpose. Company names, logos and product names are registered trademarks or trademarks of their respective owners. Broadcast Sports International or any of its group companies make no claim to third-party trademarks. The use of Broadcast Sports International's products, services and materials is subject to the Broadcast Sports International General Sales Terms and Conditions.

This manual contains important information regarding the installation and operation of the Mini Tx UHD. For safe and reliable operation, installers must ensure that they are familiar with, and fully understand, all instructions contained herein. Broadcast Sports International reserves the right to revise and improve its products as it sees fit. This publication describes the state of this product at the time of publication and may not always reflect the product in the future.

In this manual, the following symbols call your attention to important information:

|   |  |
|---|--|
|  | <b>CAUTION</b><br>Indicates that care is required when proceeding to avoid damage to the system. |
|  | <b>NOTE</b><br>Used to draw your attention to additional important information.                  |
|  | <b>WARNING</b><br>Indicates a potentially hazardous situation.                                   |

### Warranty Information

All products are warranted to be free from defects in materials or workmanship for a period of 24 months. If returned within the applicable warranty period, BSI will, at its sole discretion and at no cost to the customer, repair or replace the defective product with another unit of the same or equivalent model. This warranty does not cover failures due to abuse, misuse, accident or unauthorized alterations or repairs.

### Contact details and technical support

|  |  |
|--|--|
| Real Freedom Team                                | For product information and help with missing or damaged items.<br>Email: EngineeringDepartment@BSINTL.COM<br>Tel: +1-410-564-2642   |
| Telephone Support Line                           | Product technical support is provided via a telephone support line. Trained technicians are available to offer setup and configuration advice and to assist in troubleshooting technical issues.<br>Tel: +44-(0)1923 810131  |
| Return Merchandise Authorization (RMA) Procedure | Problems that cannot be resolved on the telephone may require the device to be returned to BSI for repair. In such cases, the telephone operator will assist the customer in obtaining an RMA.<br>Please note that no returns can be accepted without a valid RMA. |

### About this manual

This manual contains safety information and information for installing, configuring, and operating a Mini Tx UHD. It applies to the following product: Mini-Tx UHD

# Contents

---

|  |    |
|--|----|
| Contents .....                                     | 3  |
| Introduction.....                                  | 6  |
| Location and functions of parts.....               | 6  |
| Top view .....                                     | 6  |
| Front view & side view .....                       | 7  |
| Bottom view .....                                  | 8  |
| Installation.....                                  | 10 |
| Overview.....                                      | 10 |
| Preparation.....                                   | 10 |
| Power requirements.....                            | 10 |
| Unpack the Mini Tx UHD .....                       | 10 |
| Additional items required for installation .....   | 10 |
| Cable requirements .....                           | 11 |
| Cable for remote ports .....                       | 11 |
| Connections.....                                   | 12 |
| Attach a Mini Tx UHD to a camera .....             | 12 |
| Attach Mini-Tx UHD to its camera back adaptor..... | 14 |
| Connection’s checklist .....                       | 15 |
| Transmitter Configuration.....                     | 16 |
| Overview.....                                      | 16 |
| Before you start.....                              | 16 |
| Mini-Tx UHD configuration.....                     | 16 |
| Main configuration page .....                      | 16 |
| Camera control settings .....                      | 17 |
| Transmit power and frequency .....                 | 18 |
| Advanced transmit settings.....                    | 20 |
| Video source, format, and encoder.....             | 20 |
| Video settings .....                               | 20 |
| Encoder settings .....                             | 21 |
| Advance encoder settings .....                     | 21 |
| Settings .....                                     | 22 |
| Network.....                                       | 23 |
| Audio .....  | 25 |

|   |    |
|---|----|
| Location .....                            | 25 |
| Operation .....                           | 26 |
| Status LEDs .....                         | 26 |
| Routine checks.....                       | 27 |
| Verify the connection to the camera ..... | 27 |
| Monitor audio and signal levels .....     | 27 |
| Troubleshooting .....                     | 28 |
| Troubleshooting main page.....            | 28 |
| Maintenance.....                          | 29 |
| Routine maintenance procedures.....       | 29 |
| Performance monitoring .....              | 29 |
| Visual inspection.....                    | 29 |
| Cleaning .....                            | 29 |
| Storage .....                             | 29 |
| Update the transmitter's firmware .....   | 30 |
| A Technical data .....                    | 31 |
| Dimensions .....                          | 31 |
| Mini- Tx UHD Quad Input .....             | 31 |
| Mini-Tx UHD single input.....             | 32 |
| Specifications.....                       | 33 |
| Audio .....                               | 33 |
| Video.....                                | 33 |
| Camera Control .....                      | 34 |
| RF (Tx).....                              | 34 |
| RF (Rx).....                              | 34 |
| Connectors .....                          | 35 |
| Physical .....                            | 35 |
| Environmental .....                       | 35 |
| Future Releases (*).....                  | 35 |
| Connector pinout assignments .....        | 36 |
| Antenna port – RF output.....             | 36 |
| Antenna port – UHF input .....            | 37 |
| ASI / SDI video input.....                | 37 |
| Audio & Camera control.....               | 37 |

|   |    |
|---|----|
| Power.....  | 38 |
| Audio (Single Front Panel).....                     | 38 |
| Camera Control (Single Front Panel).....            | 39 |
| B Safety and regulatory compliance.....             | 40 |
| Safety notice.....                                  | 40 |
| Electromagnetic compatibility – Class A .....       | 40 |
| Compliance statement (United States) .....          | 40 |
| CE Declaration of Conformity (European Union) ..... | 40 |
| Disposal and recycling – European Union.....        | 40 |

# Introduction

The award winning Mini-TX UHD is the world's smallest ultra-low latency UHD wireless video transmitter on the market, measuring just 85mm long by 56mm wide and 28mm deep. It can transmit in two entirely different frequency bands via its software-defined radio, offering complete on-site spectrum flexibility without the need for changeable radio modules. But, even with its compact size, the Mini-Tx UHD includes all the features expected from a traditional wireless video transmitter, and more, with pre-distortion, GPS, Wi-Fi, and a 3-axis accelerometer as standard and a dual UHF receiver to add robustness and flexibility to the camera control.

The Mini-Tx UHD also includes changeable connector panels for different applications, like a single UHD/HD video input, Quad HD/Single UHD inputs or Quad HD with power and control over SDI. Additional features available with the Mini-Tx UHD include video formats up to 2160p59; HEVC and AVC video encoding at 8/10-bit 4:2:2/4:2:0; up to 32 Mbps video bitrate per pedestal; four channels of embedded SDI audio; two channels of analogue MIC/Line selectable audio with MIC phantom power; MPEG1L2 audio encoding; support for HDR; and Tx frequency options from 1.4 to 7.5 GHz. The transmitter also allows power and BSI data to be transmitted over SDI (HD only).

## Location and functions of parts

This section provides an overview of the components and connectors on the Mini Tx UHD. You should familiarize yourself with this information before installing and operating the transmitter.

### Top view

The top of the Mini-Tx UHD's RF section provides connectors to attach a UHF input antenna and an RF output antenna.

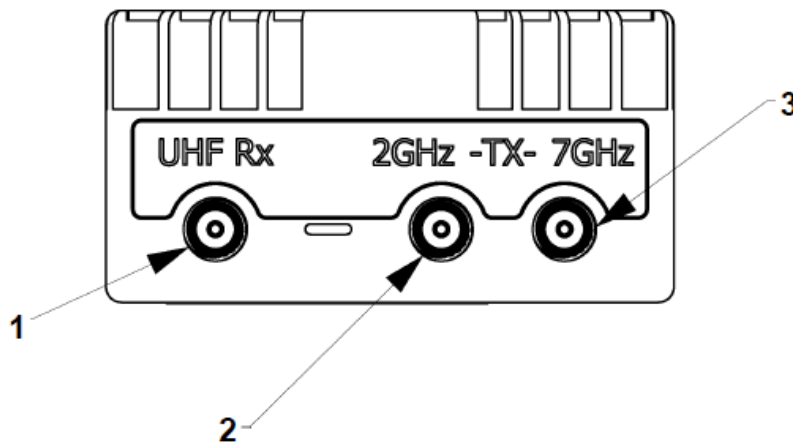

| Key | Component                 | Description  |
|-----|---------------------------|--|
| 1   | SMA connector             | Use to connect a UHF antenna to receive camera control data from a data transmitter. |
| 2   | SMA connector (Low-band)  | Use to connect an RF antenna of frequency 1.4 or 2GHz to the Mini Tx UHD.            |
| 3   | SMA connector (High-band) | Use to connect an RF antenna of frequency 7GHz to the Mini Tx UHD.                   |

## Front view & side view

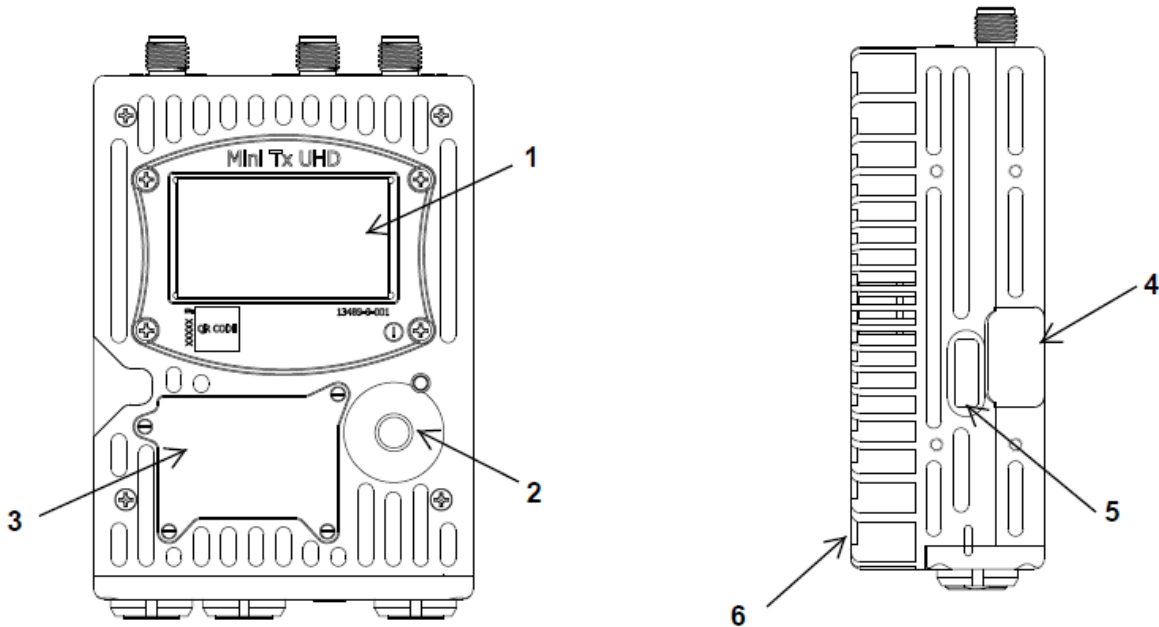

| Key | Component     | Description   |
|-----|---------------|---|
| 1   | LCD           | Use to view status information and configurations of the Mini Tx UHD.   |
| 2   | Joystick      | Use to navigate through the Mini Tx UHD's display screen. Press and hold 'Enter' on the joystick for more than 4sec to enter the menu page.<br>Toggle the joystick up/down to change values and left/right to scroll through the menus. |
| 3   | GPS Antenna   | Use to receive GNSS signals needed for the Mini-Tx UHD to relay location information.   |
| 4   | Wi-Fi Antenna | Use to wirelessly communicate with other networking devices.  |
| 5   | Micro USB     | Use to provide firmware upgrade, peripheral connection, and USB to Ethernet dongle.   |
| 6   | Fan housing   | Ensures proper heat transfer and circulation of air to avoid over-heating of the Mini-Tx UHD.   |



**CAUTION:** Do not cover the Wi-Fi and GPS antennas with any RF blocking items as it can disturb the signal in an unpredictable way.

## Bottom view

View the bottom view of Mini-Tx UHD for single input and quad input below,

### Mini-Tx UHD Single Input

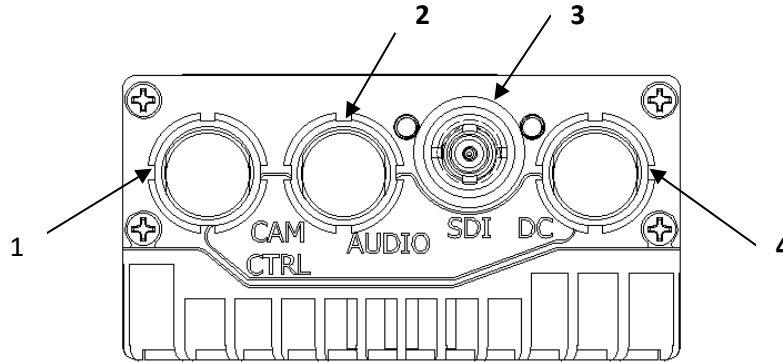

| Key | Component | Description  |
|-----|-----------|--|
| 1   | CAM CTRL  | Use to connect the camera back transmitter to the 'Remote' port on the camera to control camera settings. See <a href="#">Cable for Remote ports</a> to connect different cameras to the Mini-Tx UHD.<br>Connector: LEMO 0B 7-pin. |
| 2   | AUDIO     | Use to connect a microphone or audio signal from signal-processing equipment and mixing consoles.<br>Connector: LEMO 0B 6-pin  |
| 3   | SDI       | Use to connect the Mini-Tx UHD to the camera's SDI port if you are using SDI as the video source.<br>Connector: HD-BNC (F).  |
| 4   | DC        | Use to connect an external DC power supply(8-20 V) to power the Mini-Tx UHD.<br>Connector: LEMO 0B 2-pin   |

## Mini-Tx UHD Quad Input

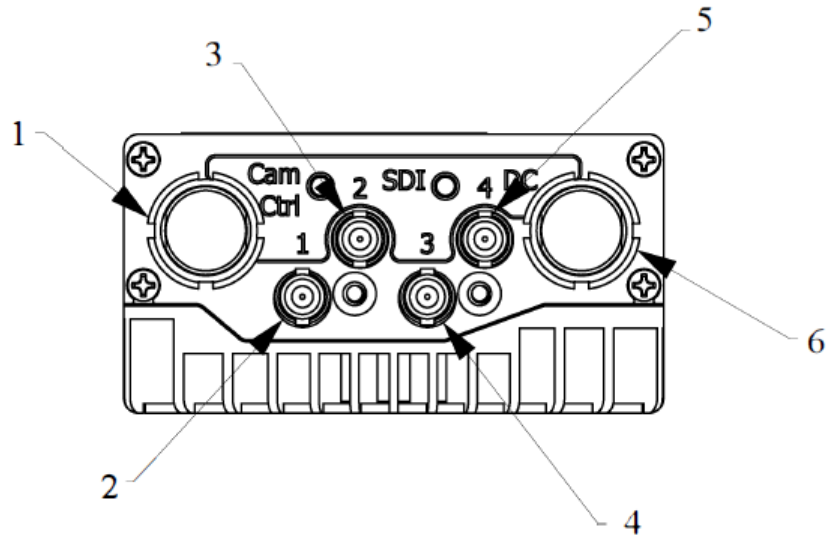

**NOTE:** The front panel board of Mini-Tx UHD has three versions of SDI input which are all valid, single UHD input, Quad 12G, and Quad 3G-CXP input.

| Key | Component | Description  |
|-----|-----------|--|
| 1   | AUX       | Use for auxiliary data and analog audio input.<br>Connector: LEMO 0B 9-pin   |
| 2   | SDI IN 1  | Use to connect the Mini-Tx UHD to the camera's SDI port if you are using SDI as the video source.<br><br>The Mini-Tx UHD has the following versions of SDI input- single UHD input, quad 12G input, and quad 3G-CXP input.<br>Connector: HD-BNC (F). |
| 3   | SDI IN 2  |  |
| 4   | SDI IN 3  |  |
| 5   | SDI IN 4  |  |
| 6   | 8-20 V DC | Use to connect an external DC power supply to power the Mini-Tx UHD.<br>Connector: LEMO 0B 2-pin   |

This chapter contains the installation instructions for the Mini Tx UHD.

Before installing, you should familiarize yourself with the [Location and functions of parts](#), which provides information about the Mini Tx UHD.

## Overview

The main installation steps for a Mini Tx UHD are as follows:

1. Attach the camera mount to the camera.
2. Attach the Mini Tx UHD to the camera mount.
3. Connect the Mini Tx UHD to the camera.

## Preparation

Before connecting and configuring the Mini Tx UHD, you should familiarize yourself with the transmitter's environmental and power requirements.

| Specification | Details              |
|---------------|----------------------|
| Humidity      | 95% non-condensing   |
| Temperature   | -20 to +45 degrees C |

Table 1: Environmental requirements

## Power requirements

The following table summarizes the power requirements for a Mini-Tx UHD.

| Specification | Details                      |
|---------------|------------------------------|
| Connector     | LEMO 0B 2-pin ECG.0B.302.CLV |
| Supply        | 8-20 V DC                    |

Table 2: Power requirements

## Unpack the Mini Tx UHD

Unpack the Mini Tx UHD and refer to the packing list to ensure that all items are included. Report any missing items immediately to the Real Freedom Team.

Inspect the Mini Tx UHD for signs of damage. Report any damage to the Real Freedom Team.

## Additional items required for installation

To install the Mini Tx UHD, you will require the following additional items:

- Camera

The Mini Tx UHD is compatible with most hand-held broadcast cameras.

- Camera mount.

BSI supply custom ‘camera backs’ that attach to different types of commercial cameras. These mounts have an integrated battery sled and power cables and allow the Mini Tx UHD to be connected to the camera.

- 8-20 V DC power supply.

## Cable requirements

To install the Mini Tx UHD, you will require the following cables:

- Coaxial cables with HD-BNC connectors.

It is recommended that you use good quality 75 Ohm cable.

***If you are using a single input panel the LEMO cables are 7-pin and 6-pin.***

- LEMO cable (JGG.0B.302.CLAD32, JGG.0B.309.CLAD52).



**NOTE:** The cable for the remote parts depends on the front panel of the Mini-Tx UHD and the type of camera. To order the cables from [Cable for remote parts](#), contact the Real Freedom Team.

## Cable for remote ports

Below are the list part numbers of cables that is used to connect different cameras to the Mini-Tx UHD.

| Cables Part Number | Camera                         |
|--------------------|--------------------------------|
| 13489-5-020        | Sony Camera                    |
| 13489-5-021        | Sony SDI                       |
| 13489-5-024        | GV LDK Camera                  |
| 13489-5-025        | GV LDXC Camera                 |
| 13489-5-026        | GV LDX Camera                  |
| 13489-5-027        | GV LDX-NEP Camera              |
| 13489-5-033        | Dreamchip Camera               |
| 13489-5-040        | Sony Camera Quad               |
| 13489-5-041        | Sony Camera & Audio Quad       |
| 13489-5-042        | GV LDK Camera Quad             |
| 13489-5-043        | GV LDK Camera & Audio Quad     |
| 13489-5-044        | GV LDXC Camera Quad            |
| 13489-5-045        | GV LDXC Camera & Audio Quad    |
| 13489-5-046        | GV LDX Camera Quad             |
| 13489-5-047        | GV LDX camera & Audio Quad     |
| 13489-5-048        | GV LDX-NEP Camera Quad         |
| 13489-5-049        | GV LDX-NEP Camera & Audio Quad |
| 13489-5-050        | Marshall Camera Quad           |
| 13489-5-051        | Marshall Camera & Audio Quad   |

Table 3: Cable for remote ports

## Connections

Refer to the [Location and functions of parts](#) which shows the locations of the connectors on the Mini-Tx UHD.

### Attach a Mini Tx UHD to a camera

Use an appropriate BSI camera back to attach the Mini-Tx UHD to the camera.

The following procedure describes how to attach a Mini-x UHD to a Sony camera using a BSI camera back (20005-9-002).

1. Attach the shoe assembly, V edge (1), to the camera using four M3 x 10 screws.

Alternatively, attach a BSI camera shoe (3) to the camera using four M3 x 10 screws.

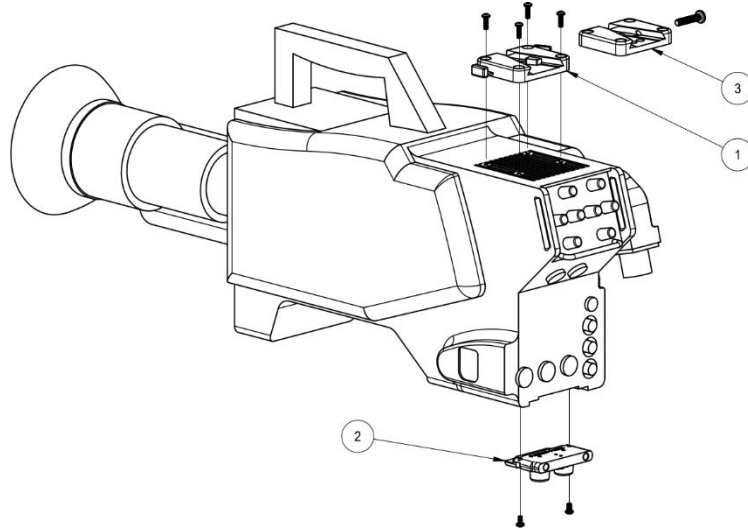

2. Attach the lower hook (2) to the camera using two M3 x 6 screws.
3. Attach the camera back (4) to the camera. To do this slide the V wedge on the camera back into the shoe assembly and the lower mounting block into the lower hook. If you are using a BSI camera shoe, secure the V wedge with an M5 x 25 screw.

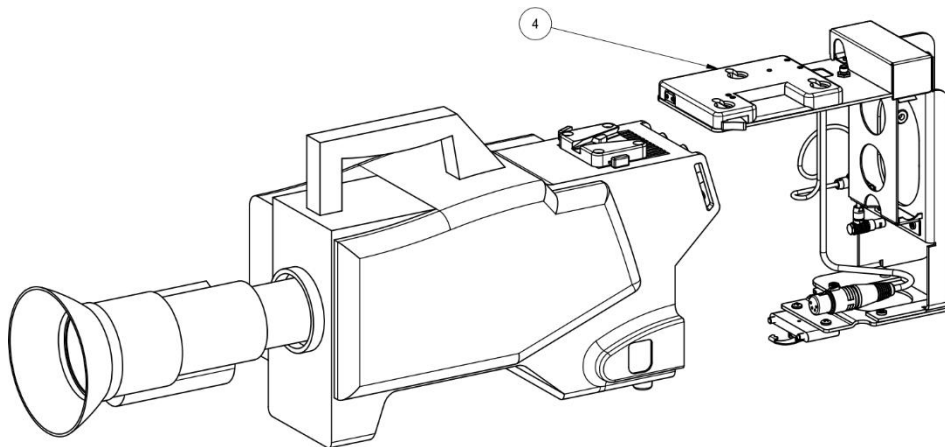

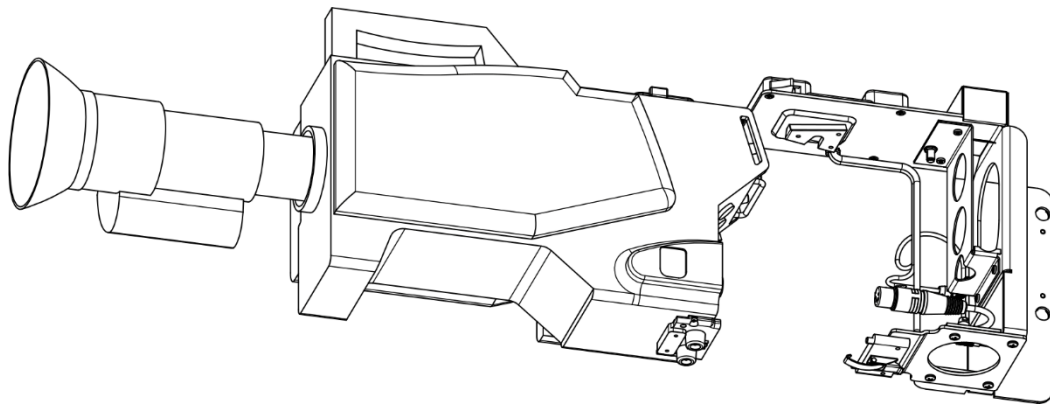

4. Attach mounting studs to the side of the Mini-Tx UHD (5) using M5 x 15 flat head socket cap screws. To attach Mini-Tx UHD to its camera back adaptor like in (5) below, [follow these steps](#).

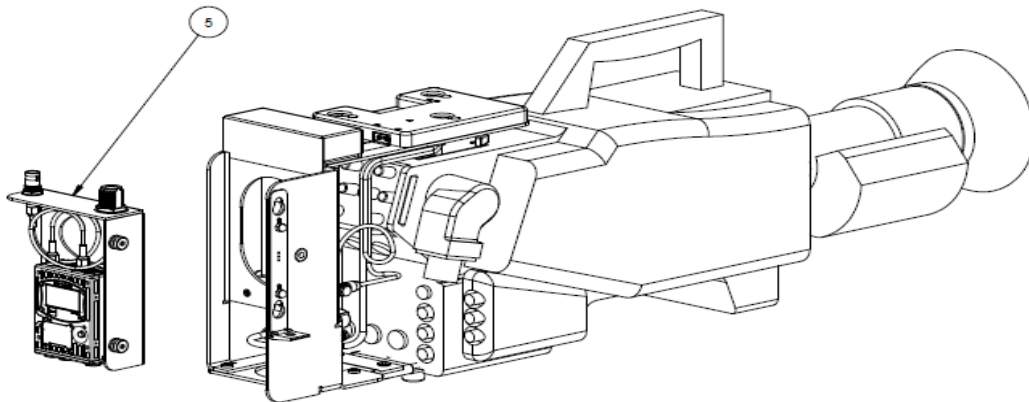

5. Align the mounting studs with the holes in the mounting bracket and engage the Mini-Tx UHD (5). Push the transmitter latch up and close the safety latch.

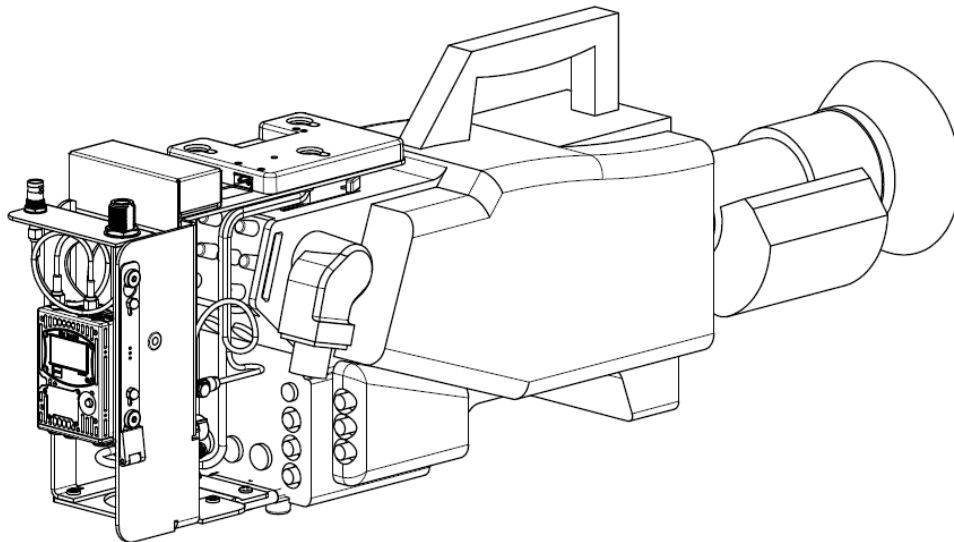

6. Attach the battery (6) to the camera back.

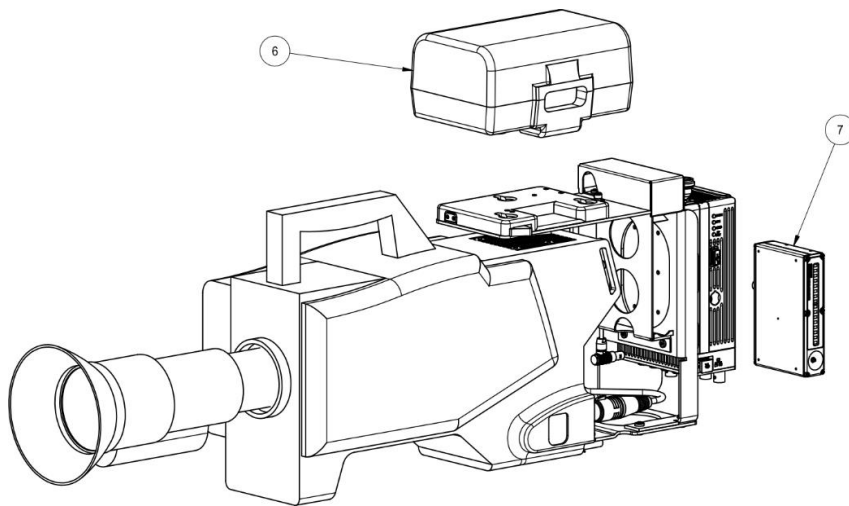

- 7. Insert the return video receiver (7) into the slot in the camera back. The receiver clips into place.
- 8. Attach the power cables to the camera, Mini-Tx UHD, and return video receiver.

### Attach Mini-Tx UHD to its camera back adaptor

- Attach cable assembly antenna (2) to the Mini-Tx UHD antenna connectors.

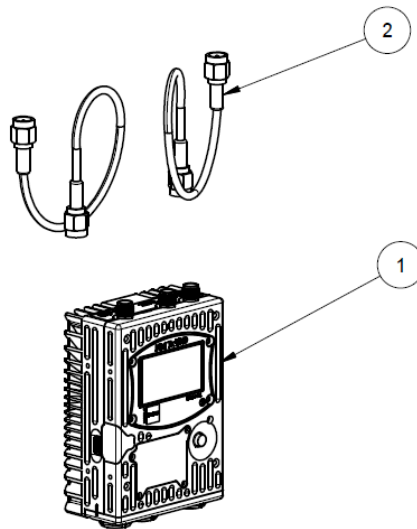

- Place the attached Mini-Tx UHD in its camera back adaptor (3) and secure it with the 20005-9-087 UHD screw.

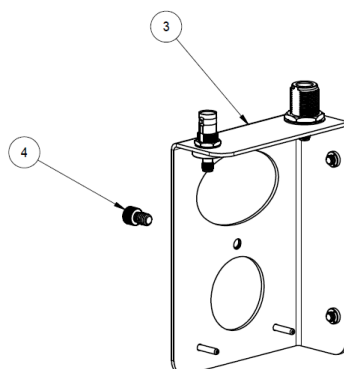

## Connection's checklist

Use the following table to ensure that the connections to the Mini Tx UHD are correct.

| Component           | Connector/cable type       | Notes                       |
|---------------------|----------------------------|-----------------------------|
| Mini Tx UHD power   | LEMO 2-pin to battery pack |                             |
| Mini Tx UHD video   | HD-BNC to camera SDI       |                             |
| Mini Tx UHD antenna | SMA (F)connector           |                             |
| Mini Tx UHD audio   | LEMO 9-pin or AUX          |                             |
|                     | LEMO 6-pin                 | Apply to single front panel |
| Mini Tx UHD control | LEMO 9-pin or AUX          |                             |
|                     | LEMO 7- pin                | Apply to single front panel |

Table 4: Connection's checklist

# Transmitter Configuration

Once powered, use the joystick on the Mini Tx UHD to configure the transmitter and view status information.

## Overview

To configure the Mini Tx UHD, you must do the following:

1. Set the transmit frequency and adjust the transmit power.
2. Set the camera control frequency.
3. Define the camera type and camera number.
4. Assign audio settings.

## Before you start

To configure the Mini Tx UHD, you will need the following information:

- Transmit and camera control frequencies.
- Camera type and camera number from the camera's control panel.

## Mini-Tx UHD configuration

The LCD screens display the configuration setting of the Mini-Tx UHD. Toggle the joystick up/down to set the required number or parameter select the required setting. Once you set the parameter, press joystick in the centre. The information and settings on the main configuration page are as follows:

### Main configuration page

Use this main page to define the camera number, camera type, Real Freedom Receiver frequency, and data frequency.

|                    |   |
|--------------------|---|
| 12-- 62C -67.0     | 1 |
| ID 01 462.93750 TX | 2 |
| POV 2265.000       |   |
| 1: 1080p50 16.1M   | 3 |

1. Displays diagnostic information.
2. Set the required camera ID number and camera type. In the example, 462.93750rx is the data transmitter frequency and 2265.000 is the frequency of video, audio, and telemetry CAN data.
3. Displays the input video format when the Mini-Tx UHD is powered and connected to the camera. In the example, 1080p50 is the video format. 16.1M is bandwidth of total data that include video, audio, and telemetry. This bandwidth is based on the constellation, code rate, and guard interval parameters in [Transmit](#) settings.



**NOTE:** The camera ID is shown on the camera's Operator Control Panel/Remote Control Panel

## Camera control settings

Tap the camera number icon to display the **Camera Control** page. Use this page to enter details of the of the camera that you are using. It is important to enter all the settings correctly so that the camera transmitter can communicate with the camera.

When you have selected the appropriate settings, toggle the joystick left to return to the main page.



| Setting              | Description   |
|----------------------|---|
| Cam Control          | You need to set the required camera control frequency, which is the frequency used by the data transmitter to send camera control data to the Mini-Tx UHD. You also need to ensure that the camera type and it's ID are set correctly.<br>Tap the current value, change the numbers to the required frequency by toggling the joystick up/down. |
| Camera Type/Protocol | Defines the camera type – Auto, Sony, POV, Ike, GV, Pelco, Visca, In car.<br>Tap the current type, toggle the joystick up/down to choose the camera type that you want.   |
| Call: Sony           | Camera Type set to 'Sony'.<br>Sony Call is required on Sony camcorder-style cameras to allow tally to operate.  |
| GV Series            | Camera Type set to 'Grass Valley'.<br>Tap to define the camera series, either 'LDK' or 'LDX'.   |
| Ikegami Mode         | Camera Type set to 'Ikegami'.<br>Tap to select the value mode, 'Absolute' or 'Relative'.<br>Refer to the camera's operator control panel manual for an explanation of these settings.   |



| Power Trigger | In the web/UI menu configuration, you now have the below options for external Tally. |  |
|---------------|--|--|
|               | Power Trigger  | Power Outcome  |
|               | On   | Power is On unconditionally  |
|               | Off  | Power is Off unconditionally(forced for HW missing the pin)  |
|               | TallyR   | Power follows Tally Red  |
|               | TallyG   | Power follows Tally Green  |
|               | Tallies  | Power is Off only if both Tallies are Off  |
|               | CamPwr1  | Power follows Camera Power (1 <sup>st</sup> camera)  |
|               |     | <b>NOTE:</b> This configuration for camera control power pin is available on Mini-Tx UHD single input front panel board from software update v3.2.5 only.  |
|               |     | <b>IMPORTANT:</b> This output is a battery voltage pass-thru and this will probably require some external regulation to drive a tally LED. The output has a load switch to protect against short-circuit and the usual on-site miss wiring, etc. |

Table 5: Camera control settings

## Transmit power and frequency

Use this **Transmit** page to define advanced settings used to transmit the video signal. When you have selected the appropriate settings, toggle the joystick left to return to the main page. You must define the transmit power and frequency. Note that the transmit frequency set here and the receive frequency set on the receiver must be the same.



| Setting                  | Description   |
|--------------------------|---|
| TX Power                 | <p>Defines the transmit output power. Toggle the joystick up/down to set the required power.</p> <p>Transmit power directly impacts signal range. The more power, the longer the range. Increasing the power can also make the signal more stable, but keep in mind it can have a negative effect on battery life.</p> <p>If the power is too low, the camera range may be insufficient resulting in loss of RF signal and video image.</p>   |
| Transmit Frequency (MHz) | <p>Set the transmit frequency assigned for your event.</p> <p>Set the current value, change the numbers to the required frequency and toggle joystick left to return to the main menu.</p> <p>Note that you can keep the transmit and receive frequency at the same value by selecting the <b>Update Receive Frequency</b> option from the receiver's <b>Remote Tx Ctrl</b> menu. Then, if you change the transmit frequency, the receive frequency automatically changes to the same value.</p>                      |
| Bandwidth                | <p>Specifies the bandwidth of operation. For DVB-T, choose from 5 MHz, 6 MHz, 7 MHz, or 8 MHz</p>   |
| Constellation            | <p>DVB-T offers three different modulation schemes: QPSK, 16QAM, and 64QAM.</p> <p>Lower order modulation formats like QPSK (Quadrature Phase Shift Keying) do not transmit as much data compared to higher modulation formats such as 64QAM (Quadrature Amplitude Modulation), but they can be received when signal strengths are lower.</p> <p>Note that as the QAM order increases, there is a higher possibility of introducing data errors since these schemes are less resilient to noise and interference.</p> |
| Code Rate                | <p>Match the code rate to the requirements of the broadcast network. The higher the level of error correction that is applied, the greater the level of supporting error correction data that needs to be transmitted, which reduces the data rate of the transmission.</p> <p>For example, if you select 3/4, for every 3 bits of data, you are sending out 4 bits, one of which is for error correction.</p>  |
| Guard Interval           | <p>Choose the appropriate guard interval so that distinct transmissions do not interfere with each other.</p> <p>In DVB-T, four guard intervals are available: 1/32 provides the lowest protection and the highest data rate, 1/4 results in the best protection but the lowest data rate.</p>  |
| FFT/Carriers             | <p>Choose the mode of operation, either 2K, 4K or 8K mode.</p> <p>Use 2K mode for single transmitter operation and for small single frequency networks with limited transmitter distances.</p> <p>Use 8K mode both for single transmitter operation and for small and large single frequency networks.</p>  |

Table 6: Transmit configuration

## Advanced transmit settings

| Setting        | Description   |
|----------------|---|
| Dual Pedestal  | Specifies whether you want to use a double-capacity wireless link.<br>'Off' creates a single video link.<br>'On' creates a single video link with double capacity.<br>'2-stream' creates pedestals for two separate video streams.<br>In 'BSI control' mode, the selected setting syncs from the receiver to the transmitter.   |
| Pre-Distortion | Specifies whether to use pre-distortion to improve the linearity and efficiency of the transmitter's amplifier and reduce interference. The recommended setting is 'On'. <b>Pre-Distortion is only available for the Low-Band (1.4GHz or 2GHZ)</b><br>Choose 'Power Save' to allow the device to 'sleep' between periods of transmission and reception, which lowers power consumption and can increase battery life. |
| Pilot Offset   | This is an advanced setting used to offset the RF spectrum by one sub-carrier. Default setting is 'Off'.  |

Table 7: Advanced transmit settings

## Video source, format, and encoder

### Video settings

You need to define the video input source and the settings that you want to use to prepare the video for output.

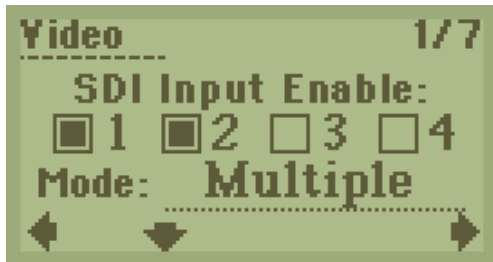

| Setting          | Description   |
|------------------|---|
| SDI Input Enable | <b>SDI Input Enable:</b> Use to enable the input SDI slots when connecting Mini-Tx UHD to the camera's SDI port if you are using SDI as the video source. You must manually enable these slots depending on the input mode 12G, dual 6G or quad 3G.<br><b>Mode:</b> Choose the mode depending on the SDI input- Single (for 12G), Dual-Link (for dual 6G), Quad-Link (for Quad 3G), and Multiple (to choose 1,2,3 or 4 inputs). |
| PoCXP            | Defines warning for the power over Coax-Express. When using external power supply to camera or video source, turn off the DC power in the Mini Tx UHD.  |

Table 8: Video settings

**WARNING: PoCXP****!DC Power to be supplied!**

Defines warning for the Power over CoaXPress. When connecting to a camera that does not support PoCXP it is recommended to turn off the DC power in the Mini Tx UHD. The Mini-Tx UHD will only enable PoCXP when it detects a CXP capable camera.

**Encoder settings**

Use the four LCD control screens to apply encoder settings to individual video inputs. Define the settings that you want to use to prepare the video for output.



| Setting        | Description   |
|----------------|---|
| Video Encoding | Displays the selected standard, HEVC or H.264. Select the codec that you require.   |
| Video Format   | Defines the resolution of the video file. Select the format that you want to use from those available (720p, 1080p, 1080p (3G), and 2160p). |
| Bit Depth      | Choose whether to use 8-bit or 10-bit color.  |

Table 9: Encoder settings

**Advance encoder settings**

| Setting | Description  |
|---------|--|
|         | <p><b>Refresh Settings</b></p> <p><b>Refresh:</b> Defines the number of times a still frame is shown or refreshed per second. Use 'Slow' or 'Fast' for longer latencies and choose 'Fastest' for shorter latencies.</p> <p><b>Direction:</b> Vert/Horiz</p> <p><b>Quantize:</b> Recommended setting is 'Auto'.</p> <p> <b>NOTE:</b> Uniform and (QP) Range are advanced settings for engineering only.</p> |
|         | <p><b>Quantize Range</b></p> <p>The quantization parameters govern the accuracy values. A lower quantization parameter results in a better picture but higher bit-rate. The recommended setting is 'Auto'.</p>   |

| Setting   | Description   |
|---|---|
|  | <p><b>Latency</b><br/>For each SDI input, latency can be defined using the controls, CPB and slices.</p> <p><b>CPB:</b> This is an advanced setting that allows you to control the size of the encoder's Coded Picture Buffer.</p> <p><b>Slices:</b> Use this setting to control subframe encoding, which cuts down latency by pipelining slices instead of frames.</p>   |
| Chroma  | <p>Chroma subsampling is a method for compressing color data in a video signal or file. It reduces the amount of color information in the signal to allow more luminance data instead and allows you to maintain picture clarity while effectively reducing the file size by up to 50%. Select the ratio that you want to use.</p> <p>The Mini-Tx UHD supports 4.2.2.</p> |
| Video Delay Mode  | <p>Defines whether to use 'Normal', 'Low' or 'Ultra Low' video encoder latency.</p> <p>Note that you must ensure that you set the correct Video Latency setting on the receiver, which depends on the Video Delay Mode that you select here. If latency is set incorrectly on the receiver, the image may freeze or judder.</p>   |

Table 10: Advance encoder settings

## Settings

The **Settings** page has the following options:



| Option    | Description  |
|-----------|--|
| LCD Off   | Controls when the LCD screen will turn off when the Mini-Tx UHD is powered on.<br>Default setting is 'Never' |
| Backlight | Use to set the brightness of the entire screen.<br>Default setting is 'Auto'                                 |

Table 11: Settings options

## Network

The **Network** page displays the current network configuration, including whether the IP address is static or allocated by DHCP.

Navigate to **Network** and toggle the joystick down to configure as follows.



| Setting  | Description  |
|--|--|
|   | <b>Net wired</b><br>Displays IP address and netmask of the Mini Tx UHD and provides Mini-Tx terminal access for debugging via wired USB cable. Enter the required IP address and subnet/network mask to identify the Mini-Tx UHD on the network.   |
|   | <b>Net Wi-Fi</b><br>Use to access Mini Tx UHD through multiple devices within the network coverage area over Wi-Fi. Use 'PIN' number that is mentioned on the LCD display as the password while connecting to the Mini Tx UHD Wi-Fi network.   |
|  | <b>Net dongle</b><br>Use to access Mini Tx UHD using a USB to Ethernet dongle, through DHCP or Static IP address. Static IP: Enter the static IP address to identify the Mini Tx UHD on the other network. DHCP: Use DHCP to dynamically assign an IP address and other network configuration parameters to the transmitter. |

Table 12: Network configuration

### Accessing Mini-Tx UHD via Net Wi-Fi

The configuration settings of Mini-Tx UHD can be calibrated by connecting it to mobile phone. When connecting Mini-Tx UHD to the iOS device and if its auto-connected, it is recommended to forget the access point and re-connect to manually enter the password once again.

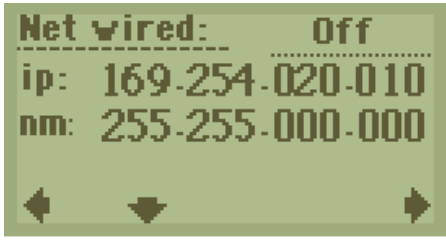
To access the Mini-Tx UHD via mobile phone, follow these steps:

- From the main menu, toggle the joystick left/right to reach **Net Wi-Fi** in [Network](#) settings.
- Connect to the Wi-Fi network **minitxuhd** in your phone or PC.
- When prompted, enter the password '00000000'.
- Mini-Tx UHD can now be configured via connected device.

### Accessing Mini-Tx UHD via Net dongle

To access the Mini-Tx UHD via net dongle, follow these steps:

- From the main menu, toggle the joystick left/right to reach **Net dongle** in [Network](#) Settings.
- Connect Mini-Tx UHD to the ethernet cable using a USB to Ethernet dongle.
- Navigate to your browser and follow the link, <http://minitxuhd.local>
- Mini-Tx UHD can now be configured via browser.

## NOTES:

- The configuration settings of Mini-Tx UHD can be controlled by connecting it to PC.
- Once you're done controlling Mini-Tx UHD on your iOS device, just swipe up to exit the UI. iOS then drops the connection and reconnects to the Wi-Fi connection you were using for Internet. Therefore, you can switch between your Wi-Fi AP for Internet and Mini-Tx UHD Wi-Fi AP for the UI.
- The only address that would work in Safari is [minitxuhd.local](http://minitxuhd.local). It would let you access the UI again, albeit with more steps. iOS would also remember the access point and bypass the login screen, so you're losing the quick switch between Internet and Mini-Tx UHD UI.



**CAUTION:** Do not click "Cancel" to exit the Login screen causes iOS to stay connected to Mini-Tx UHD but no longer display the UI. As Mini-Tx UHD is not an Internet Gateway, the phone may get upset.

Below is an example of the main configuration page of Mini-Tx UHD when accessed on browser via Net Wi-Fi or Net dongle.

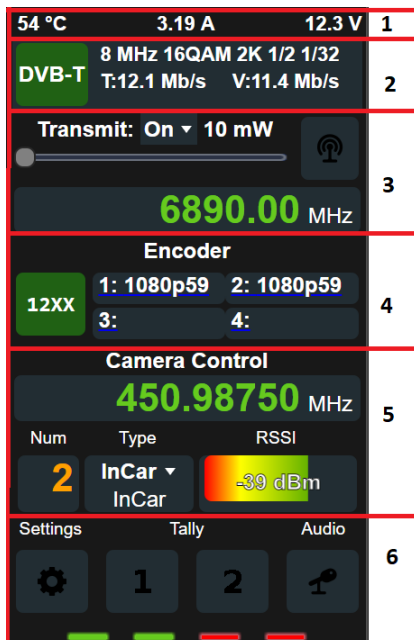

1. Displays diagnostic information.
2. Displays the settings for the transmission standard DVB-T. se this area to change the standard and settings. In the example, V: 26.0 Mb/s is the video bit rate, and 18.1 is the total bitrate including video, audio, and telemetry.
3. Displays the transmit power and frequency. Tap the transmit icon to define advanced transmit settings.
4. Displays the video source and format.
5. Displays the camera control frequency, the camera type and ID, RSSI (Received Signal Strength Indicator) or SNR (Signal to Noise Ratio) and tally indicator. Tap the camera number to define camera settings.
6. Displays settings, including network configuration, tally, and audio settings. The four green/red bars at the bottom of the screen indicate the status of each of the four video inputs.

## Audio

From the main screen, navigate to **Audio** and configure as follows.



| Setting   | Description   |
|---|---|
|  <p>Audio 1/3<br/>1-2: 3-4:<br/>MPEGL2 MPEGL2<br/>SDI:1-2 Analog</p>                                 | <p><b>Channel 1-2:</b><br/>MPEGL2 Compresses audio on channel 1 and 2.</p> <p><b>Channel 3-4:</b><br/>MPEGL2- Compresses audio on channel 3 and 4.</p>            |
|  <p>Audio 2/3<br/>1: 0dB Line<br/>2: 0dB Line</p>  | <p><b>Mic/Line:</b><br/>Sets the strength of the audio signal as either 'Mic' or 'Line' level.</p>  |
|  <p>Audio 3/3<br/>Phantom: Voltage:<br/><input type="checkbox"/>1 <input type="checkbox"/>2 Off</p> | <p><b>Phantom:</b><br/>Phantom is used to enable phantom power by channel if required by the microphone.<br/>User can select a phantom voltage of 5,8 or 48V.</p> |

Table 13: Audio configuration

## Location

From the main screen, navigate to **Location** and configure as follows.

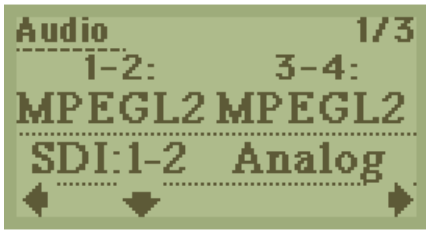

| Setting | Description  |
|---------|--|
| GPS     | Use to locate, navigate, and track the Mini-Tx UHD. GPS in the Mini-Tx UHD supports the following parameters, GNSS fix, Sat. count, date, time, latitude, longitude, altitude, speed, and default units. |
| Lock    | Use to lock the targeted signal and location tracked by the GPS.   |
| Units   | Use to defines the measurement of location as default, metric, or imperial.  |

Table 14: Location configuration

Once connected and correctly configured, no further changes are generally required to the Mini-Tx UHD during routine operation.

## Status LEDs

Use the LED indicators on the Mini Tx UHD to help you to determine whether the transmitter is operating correctly.



**NOTE:** In the bottom view of the Mini-Tx UHD, the left LED represents camera control and UHF. The right LED represents Video, GPS, and Wi-Fi.

| LED            | LED state      | Meaning  | Note                   |
|----------------|----------------|--|------------------------|
| Camera Control | Solid Red      | <ul style="list-style-type: none"> <li>The camera control frequency is set incorrectly at the data transmitter, or the Mini-Tx UHD is too far away from the data transmitter to pick up the control data.</li> </ul> | RSSI <100              |
|                | Solid Amber    | <ul style="list-style-type: none"> <li>There is no good connection between the data transmitter and the Mini-Tx UHD</li> </ul>   | RSSI <80               |
|                | Solid Green    | <ul style="list-style-type: none"> <li>There is a good signal between the data transmitter and the Mini-Tx UHD</li> </ul>  | Good RSSI              |
|                | Flashing Amber | <ul style="list-style-type: none"> <li>There is a limited data for the camera number.</li> </ul>   | RSSI <80               |
|                | Flashing Green | <ul style="list-style-type: none"> <li>Data for the camera number is good</li> </ul>   | Good RSSI              |
| Video          | Red            | <ul style="list-style-type: none"> <li>There is no connection to the link or video format to perform encoding operations.</li> </ul>   |                        |
|                | Amber          | <ul style="list-style-type: none"> <li>Cannot encode some links</li> <li>Invalid forced format</li> <li>Links are missing</li> </ul>   | MultiStream Video Mode |
|                |                | <ul style="list-style-type: none"> <li>Bad links or missing quad links</li> <li>Mismatched forced format</li> <li>Error in encoding operation</li> </ul>   | Auto, others           |
|                |                | <ul style="list-style-type: none"> <li>Encoding on all enabled inputs</li> </ul>   | MultiStream Video Mode |
|                | Green          | <ul style="list-style-type: none"> <li>Encoding successful</li> </ul>  | Auto, others           |
| GPS            | Blue           | <ul style="list-style-type: none"> <li>When GPS is turned On from Off LED blinks blue once. Thereafter, LED blinks blue every 2sec on GPS fix.</li> </ul>  |                        |
| Wi-Fi          | Magenta        | <ul style="list-style-type: none"> <li>Wi-Fi access point is enabled</li> <li>LED blinks magenta every 2sec in alternance with LED of GPS</li> </ul>   |                        |

Table 15: Mini Tx UHD LED status indications

## Routine checks

You should verify the connection to the camera and verify that the Mini-Tx UHD is receiving data from the OCP/RCP and regularly monitor audio and signal levels.



**NOTE:** You should also ensure that the transmit frequency matches the receive frequency set on the receiver and that the camera number matches the camera that you are using.

### Verify the connection to the camera

The camera type label above the camera number on the main configuration page will be flash rapidly if the transmitter is not communicating with camera.

### Monitor audio and signal levels

It is recommended that you monitor audio and signal levels while using the Mini-Tx UHD.

- Signal levels are shown on the main configuration page as RSSI.
- To view audio levels, navigate to **Audio** on the Mini-Tx UHD.

# Troubleshooting

This chapter provides troubleshooting information for the Mini Tx UHD.

Use this information to help you to solve some of the problems that you may encounter when using a Mini Tx UHD.

| Symptom                          | Possible cause  | Actions  |
|----------------------------------|---|--|
| Dark screen/display.             | <ul style="list-style-type: none"> <li>The display has 'timed out'.</li> <li>Status page has timed-out</li> </ul> | <ul style="list-style-type: none"> <li>You can disable the screen timeout from the <a href="#">Settings</a> page.</li> <li>The screen backlight is set to 'Never' by default. Adjust the screen backlight and LCD options from the <b>Settings</b> page.</li> </ul>    |
| No audio signal.                 | Incorrect audio settings.   | <ul style="list-style-type: none"> <li>Check the Mini-Tx UHD's audio settings.</li> </ul>  |
|                                  | Loose or incorrect connections at the receiver.   | <ul style="list-style-type: none"> <li>Check all physical connections on the back of the receiver. Analog audio is available at the 3-pin XLRs on the back of the receiver and embedded audio is always available on the SDI 1 and 2 outputs.</li> </ul>               |
| Connection error.                | Transmit and receive frequency set incorrectly.   | <ul style="list-style-type: none"> <li>Verify that the frequency settings on the receiver and Mini-Tx UHD match.</li> <li>Enable automatic frequency updates in the receiver's configuration so that the transmit and receive frequency is always the same.</li> </ul> |
| Poor audio signal.               | Audio settings are not correct.   | <ul style="list-style-type: none"> <li>Monitor incoming audio channels and determine if gain should be applied or reduced.</li> </ul>  |
| No remote control from receiver. | No active connection to the receiver.   | <ul style="list-style-type: none"> <li>Remote control is only possible when data is active, and the receiver is properly coded and connected to the client RCP.</li> </ul>   |

Table 16: Troubleshooting Mini-Tx UHD issues

## Troubleshooting main page

Error conditions in the main page of the Mini-Tx UHD is indicated by the parameter rapidly flashing. Use this information to analyze the error states in the main page of the Mini-Tx UHD.

| Parameter     | Symptom          | Possible cause                         |
|---------------|------------------|--|
| Camera type   | Rapidly flashing | No connection to the camera            |
| RF frequency  | Rapidly flashing | RF is not locked                       |
| UHF frequency | Rapidly flashing | UHF is not locked                      |
| Camera number | Rapidly flashing | There is a mismatch in the camera data |

Table 17: Troubleshooting Mini-Tx UHD main(status) page

This chapter describes the maintenance, cleaning, and storage procedures for Mini-Tx UHD.

## Routine maintenance procedures

You should perform the following maintenance procedures on a regular basis.



**WARNING:** The Mini Tx UHD does not contain user serviceable parts. Warranty is void if the device is opened. Refer servicing to qualified BSI personnel only.

## Performance monitoring

It is recommended that you periodically monitor the overall performance of the Mini Tx UHD and system. If you experience failure or deterioration in the performance of the system, check cables and adapters, input, and output connectors for damage.

## Visual inspection

Depending on operating environments and use, periodically inspect the Mini-Tx UHD for signs of damage, dirt, or corrosion. Check that all markings and warning labels are in good condition.

## Cleaning

If necessary, use low-pressure compressed air cleaning to remove small particles and debris from the surface of a Mini-Tx UHD.

Clean connector surfaces with a cotton swab moistened with a small quantity of alcohol. Use a lint-free cloth to wipe connector surfaces after cleaning.



**CAUTION:** Do not use abrasive cleaners.

## Storage

Store a Mini-Tx UHD either attached to the camera or in a safe location.

For long term storage:

1. Disconnect all cables from the Mini Tx UHD.
2. Detach the Mini Tx UHD from the camera.
3. Remove the antennas.
4. Cover the connectors with suitable dust covers.
5. Place the Mini Tx UHD in protective packaging and store in a cool, dry environment.

## Update the transmitter's firmware

From time to time, new firmware will become available for the Mini-Tx UHD. Be aware that updating the firmware is a sensitive process that may take some time. Make sure the transmitter is undisturbed during the upgrade and do not switch off the Mini Tx UHD during the update process.



**NOTE:** Download new firmware files from <https://www.bsintl.com/real-freedom>

To update the firmware, follow these steps:

1. From the main menu, toggle the joystick left/right to navigate to the **Firmware Update**.
2. Use the micro-USB to USB cable to insert a USB stick containing the new firmware into the Mini Tx UHD's micro-USB port.
3. Tap **Scan** to locate the new firmware.
4. To begin the update, select **Update**.
5. To complete the firmware update process, power cycle the transmitter when the message on the screen instructs you to do so

Technical drawings, specifications, and connector pinouts for the Mini-Tx UHD.

### Dimensions

#### Mini- Tx UHD Quad Input

The following drawings show the dimensions of the quad input Mini-Tx UHD.

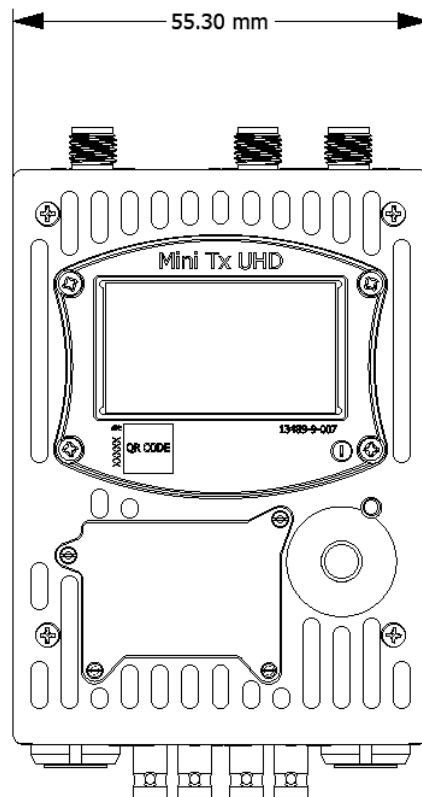

Figure X: Mini-Tx UHD (front view)

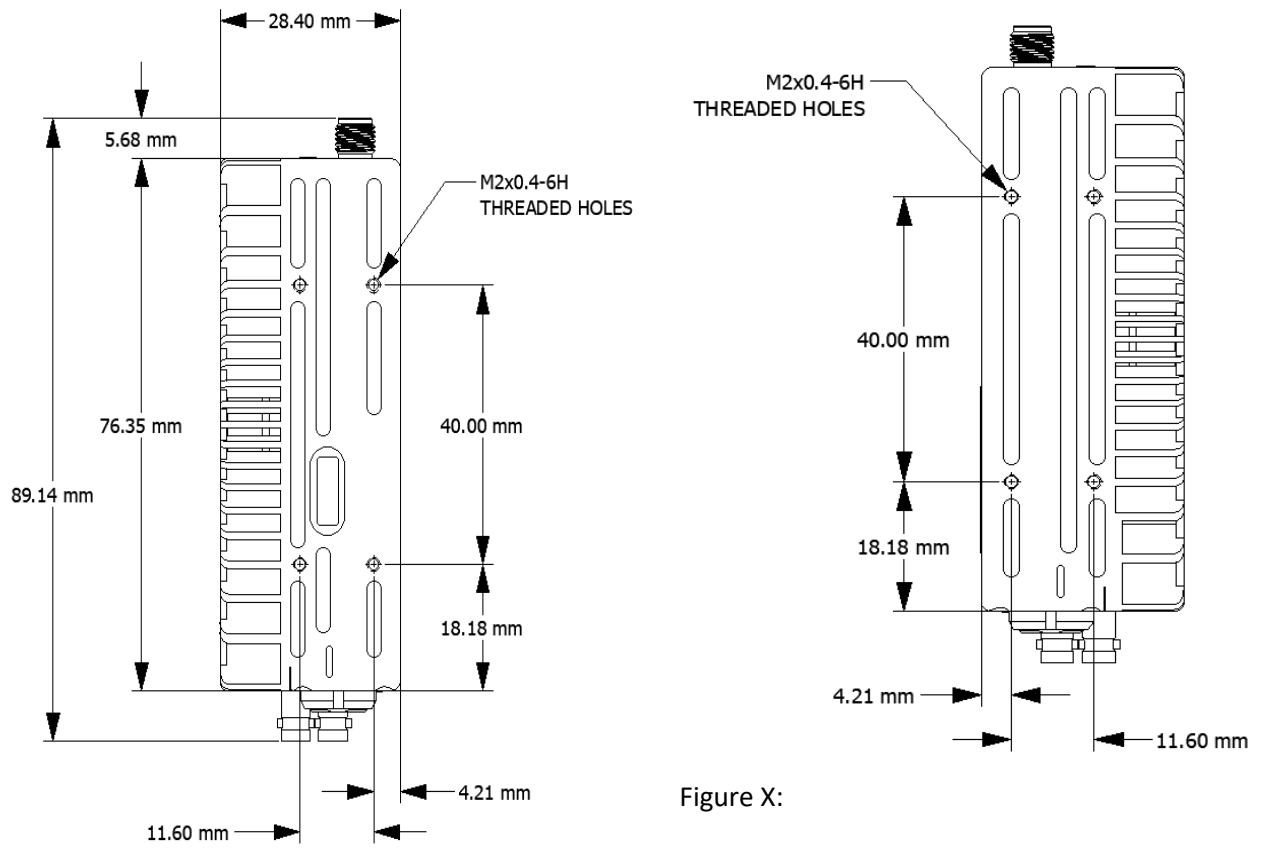

Figure X:

Figure X:

### Mini-Tx UHD single input

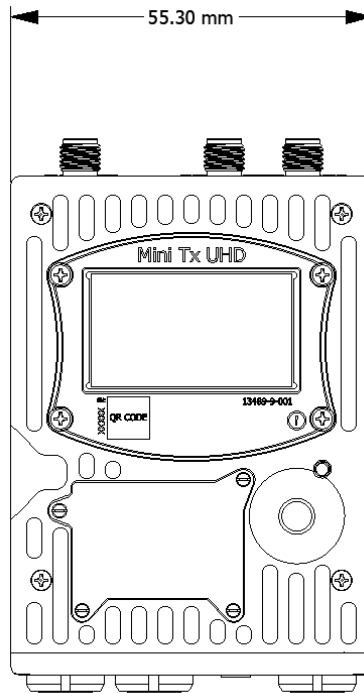

Figure X:

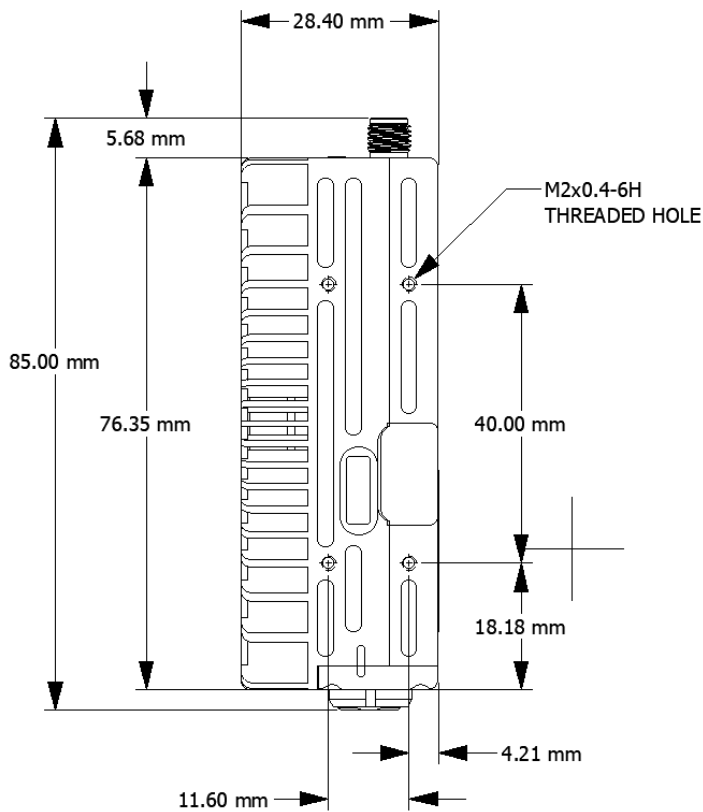

Figure X:

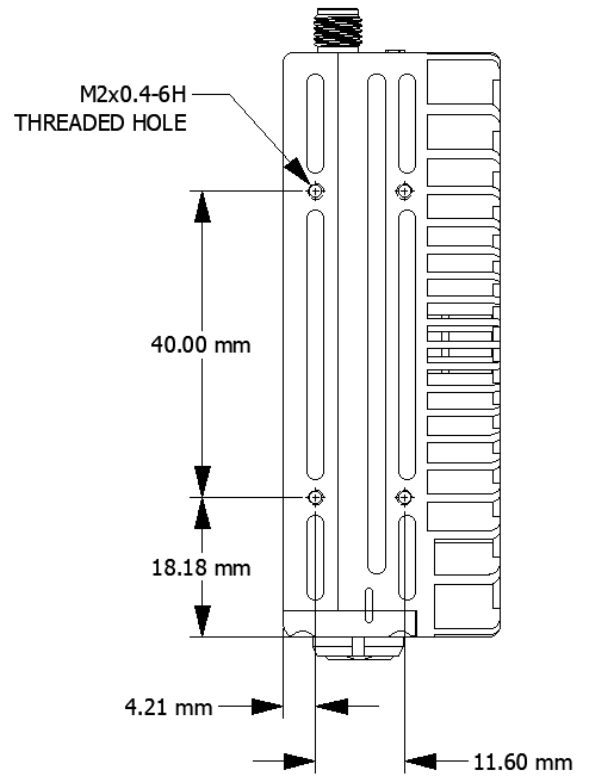

Figure X:

## Specifications

The following tables contain the specifications for the Mini-Tx UHD.

### Audio

| Parameter            | Specification                      |
|----------------------|------------------------------------|
| Embedded SDI         | Up to 4 Channels                   |
| Analog               | Up to 2 Channels                   |
| Analog Level         | Mic/Line Selectable                |
| Analog Level Max     | +18 dBu (balanced)                 |
| Analog Phantom Power | User selectable between 5V and 48V |
| Analog Encoding      | MPEG1-L2                           |

### Video

| Parameter            | Specification  |
|----------------------|--|
| Input Format         | 12G / Dual 6G and Quad 3G / HD SDI   |
| Supported Resolution | 3840x2160p59/50/29/25/24/23, 1920x1080p59/50/29/25/24/23, 720p59/50, 1920x1080i59/50 (Interlaced), Square division UHD, 2048x1080p, 4096x2160p |
| Video Encoding       | HEVC (H.265) and AVC (H.264)   |

|               |  |
|---------------|--|
| Max Bit Rate  | 63.3 Mbps  |
| Bit Depth     | 10-bit or 8-bit  |
| Chroma Format | 4:2:2 and 4:2:0  |
| Quad Features | Independent HD encoder control, Independent bit rate control |

## Camera Control

| Parameter                 | Specification   |
|---------------------------|---|
| Protocols                 | Sony, BSI, Grass Valley, Ikegami, Visca, InCar, POV, Pelco, DreamChip           |
| Data Format               | CAN Bus, RS232, RS485 serial  |
| Return Data               | Status, CAN bus, Battery (Volts), Temp, GNSS, etc.                              |
| Tx Remote Control         | RF Freq, Power, Modulation, Audio gain, etc.                                    |
| Data Transmit*            | Power and SI Data over SDI (HD only)  |
| Camera Power              | Battery volts (2A current limit)  |
| Local & Remote UI         | LCD display and Joystick navigation, Wi-Fi (iPhone/Android), Ethernet (via USB) |
| Integrated GNSS*          | GPS (L1 C/A), Galileo (E1 B/C), BeiDou (B1 L), GLONASS (L1 O/F)                 |
| Integrated Accelerometer* | Not initially supported   |
| Integrated Wi-Fi          | 2.4GHz 802.11b/g/n  |
| Integrated Bluetooth*     | Not initially supported   |

## RF (Tx)

| Parameter       | Specification                                     |
|-----------------|---|
| Scheme          | DVB-T   |
| Bandwidth       | 5, 6, 7, 8MHz                                     |
| Frequency*      | 1.4-1.6GHz & 6.4-7.5GHz , 2.0-2.5GHz & 6.4-7.5GHz |
| Tuning Step     | 250KHz  |
| Level           | 10-100 mW (inc, Pre-Distortion)                   |
| Pedestal        | Single, Dual                                      |
| DVB-T Bit-rates | 3.8 to 31.7 Mbps per pedestal                     |

## RF (Rx)

| Parameter   | Specification    |
|-------------|------------------|
| Band        | 430-470 MHz      |
| Bandwidth   | 25kHz            |
| Tuning Step | 6.25 kHz & 10kHz |

## Connectors

| Parameter            | Specification                        |
|----------------------|--------------------------------------|
| RF Tx Out            | 2 x SMA(f)                           |
| UHF Rx In            | SMA(f)                               |
| SDI Video In         | HD-BNC(f)                            |
| Analog Audio In      | LEMO 0B 6-pin(f)                     |
| Camera Control       | LEMO 0B 7-pin(f)                     |
| Audio/Camera Control | Lemo 0B 9-pin(f) (Quad version only) |
| Power                | LEMO 0B 2-pin(f)                     |
| USB                  | Micro type A/B 5-pin(f)              |

## Physical

| Parameter  | Specification                          |
|------------|--|
| Dimensions | (85.0x55.3x28.4) mm (incl. connectors) |
| Weight     | 185g (Single Input), 190g (Quad Input) |

## Environmental

| Parameter   | Specification        |
|-------------|----------------------|
| Temperature | -20 to +45 degrees C |
| Humidity    | 95% non-condensing   |
| Sealing     | IP65                 |

## Future Releases (\*)

| Parameter                | Specification                                       |
|--------------------------|---|
| Supported Resolutions    | PSF formats   |
| Data Transmit            | Power and BSI Data over SDI (UHD)                   |
| Scheme                   | DVB-T2, ISBD-T                                      |
| Integrated Accelerometer | 9-axis 3D Accelerometer, Gyroscope and Magnetometer |
| Integrated Bluetooth     | Bluetooth 4.1                                       |



**NOTE: Specifications are subject to change without notice.**

## Connector pinout assignments

Pinouts for the connectors on the Mini-Tx UHD

### Antenna port – RF output

Use to connect an RF antenna to the Mini-Tx UHD.

Connector: SMA (F)

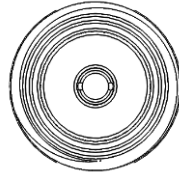

*Figure 1: Front face of the (F) RF output connector*

| Pin | Purpose                 |
|-----|-------------------------|
| 1   | RF                      |
| 2   | Signal/Low-Noise Ground |

## Antenna port – UHF input

Use to connect a UHF antenna to receive camera control data from a data transmitter.

Connector: SMA (F)

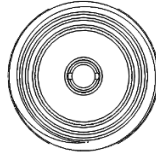

Figure 2: Front face of the (F)UHF input connector

| Pin | Purpose                 |
|-----|-------------------------|
| 1   | UHF                     |
| 2   | Signal/Low-Noise Ground |

## ASI / SDI video input

Use to connect the Mini-Tx UHD to the camera's ASI or SDI port.

Connector: HD-BNC (F) 75 Ohm

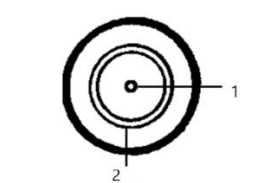

Figure 3: Front face of the HD- BNC (F) video input connector

| Pin | Purpose         |
|-----|-----------------|
| 1   | SDI Video Input |
| 2   | Ground/Shield   |

## Audio & Camera control

Connector: LEMO 0B 9-pin ECG.0B.309.CLV



Figure 4: Front face of LEMO 0B 9-pin audio & camera control connector

| Pin | Purpose |
|-----|---------|
| 1   | GND     |
| 2   | A2_R    |

|   |      |
|---|------|
| 3 | A2_L |
| 4 | A1_R |
| 5 | A1_L |
| 6 | TX_P |
| 7 | TX_N |
| 8 | RX_N |
| 9 | RX_P |

## Power

Use to connect an external DC power supply to power the Mini-Tx UHD.

Connector: LEMO 0B 2-pin ECG.0B.302.CLV



Figure 5: Front face of the LEMO 2-pin power connector

| Pin | Purpose |
|-----|---------|
| 1   | Ground  |
| 2   | Power   |

## Audio (Single Front Panel)

Connector: LEMO 0B 6-pin ECG.0B.306.CLV



Figure 6: Front face of LEMO 0B 6-pin audio(single front panel) connector

| Pin | Purpose |
|-----|---------|
| 1   | GND     |
| 2   | A1+     |
| 3   | A1-     |
| 4   | GND     |
| 5   | A2+     |
| 6   | A2-     |

## Camera Control (Single Front Panel)

Connector: LEMO 0B 7-pin ECG.0B.307.CLV



Figure 7: Front face of LEMO 0B 7-pin camera control(single front panel) connector

| Pin | Purpose              |
|-----|----------------------|
| 1   | GND                  |
| 2   | CAM POWER/ EXT TALLY |
| 3   | RX P                 |
| 4   | GND                  |
| 5   | TX P                 |
| 6   | TX N                 |
| 7   | RX N                 |

# Safety and regulatory compliance

---

Important safety and electromagnetic compatibility information.

## Safety notice

It is extremely important to read and understand all safety information and instructions before using a Mini-Tx UHD. Specific warnings and cautions are found throughout this product manual, and you should follow this guidance during the routine use of a Mini-Tx UHD.

## Electromagnetic compatibility – Class A

Information about Mini-Tx UHD's electromagnetic compatibility.

### Compliance statement (United States)

This device complies with Part 15 of the FCC Rules. Operation is subject to the following two conditions, however, set forth in Section 15.5 of the FCC Rules: (1) this device may not cause harmful interference, and (2) this device must accept any interference received, including interference that may cause undesired operation.

This equipment has been tested and found to comply with the limits for a Class A digital device, pursuant to part 15 of the FCC Rules. These limits are designed to provide reasonable protection against harmful interference when the equipment is operated in a commercial environment. This equipment generates, uses, and can radiate radio frequency energy and, if not installed and used in accordance with the instruction manual, may cause harmful interference to radio communications. Operation of this equipment in a residential area is likely to cause harmful interference in which case the user will be required to correct the interference at his own expense.

Changes or modifications not expressly approved by Broadcast Sports International could void the user's authority to operate the equipment.

### CE Declaration of Conformity (European Union)

This product meets the requirements of the following directives and carries the CE marking accordingly: 2014/35/EU Low Voltage Directive, 2014/30/EU EMC Directive.

Note that the product may operate on non-harmonized frequency bands and the actual operating frequency may differ between EU Member States.

## Disposal and recycling – European Union

This product is required to comply with the European Union's Waste Electrical and Electronic Equipment (WEEE) Directive (2002/96/EC and 2012/19/EU) and is marked with the following symbol:



This symbol indicates that this product is not to be disposed of with household waste, according to the WEEE Directive and your national law. This product should be handed over to a designated collection point or to an authorized collection site for recycling waste Electrical and Electronic Equipment (EEE).

Improper handling of this type of waste could have a possible negative impact on the environment and human health due to potentially hazardous substances that are generally associated with EEE and products of this type. At the same time, your cooperation in the correct disposal of this product will contribute to the effective usage of natural resources. For more information about recycling this product, please contact BSI.