

RemotestTM
SAFETY AT THE HIGHEST LEVEL

+

OSID

Fixfire
LIFE & PROPERTY PROTECTION

your best alliance for complianceTM



www.fixfire/remotest



Remotest™ + OSID

SAFETY AT THE HIGHEST LEVEL

Fire Detection in large open areas is fraught with challenges and Remotest™ by Fixfire® combined with OSID by Xtralis brings together two great solutions to provide game-changing reliable and affordable protection that ticks all the boxes.



Watch our simple demonstration of how OSID operates and mitigates issues associated with standard beam detection at www.fixfire/remotest

OSID Explained

OSID (Open-area Smoke Imaging Detection) by Xtralis is well proven smoke detection technology. By using advanced dual wavelength projected beams and optical imaging technology for early warning smoke detection, OSID provides a low-cost, reliable and easy-to-install solution that overcomes typical beam detection issues such as false alarm incidents and alignment difficulties.



OSID Detection Technology

The OSID devices measure the level of smoke entering beams of light projected over an area of protection. A single OSID Imager can detect up to seven Emitters to provide a wide coverage area.

Two innovations in smoke detection technology have been developed for the revolutionary OSID smoke detector:

1 Dual Wavelength Particle Detection

The beam projected from each Emitter contains a unique sequence of ultraviolet (UV) and infrared (IR) pulses that are synchronised with the Imager and enable the rejection of any unwanted light sources. By using two wavelengths of light to detect particles, the system is able to distinguish between particle sizes. The shorter UV wavelength interacts strongly with both small and large particles while the longer IR wavelength is affected only by larger particles. Dual wavelength path loss measurements therefore enable the detector to provide repeatable smoke obscuration measurements, while rejecting the presence of transient dust particles or solid intruding objects

2 Optical Imaging with a CMOS Imaging Chip

An optical imaging array in the Imager provides the detector with a wide viewing angle to locate and track multiple Emitters. Consequently, the system can tolerate a much less precise installation and can compensate for the drift caused by natural shifts in building structures. Optical filtering, high-speed image acquisition and intelligent software algorithms also enable the detection system to provide new levels of stability and sensitivity with greater immunity to high level lighting variability.

Operation

OSID technology is highly tolerant to transient dust and dirt and requires little maintenance in practice. Preventative maintenance is limited to occasionally cleaning the optical faces of the detector components. The Imagers are equipped with an onboard event memory for diagnostic purposes. Connecting the OSID Diagnostic tool allows this memory log to be downloaded for further alarm and fault analysis and troubleshooting

Features

- Maximum detection range of 200 m (656 ft)
- Requires only 20cm x 20cm view along the detection line
- Dual wavelength LED-based smoke detection
- On-board event log for fault and alarm diagnostics
- High tolerance to false alarm due to building movement
- High tolerance to transient dust, steam and intrusion of solid objects
- No need for precise alignment
- Tolerant of alignment drift providing massive compensation for building movement
- Automatic rapid commissioning in under ten minutes
- Eliminates plastic pipework required with HSSD which is better for the environment and good for improved BREEAM ratings in new construction

Detection Range

OSID may be configured to suit a range of detection spaces by selecting the number of Emitters and type of Imager. Each type of Imager differs by the lens used in the unit, which determines the field of view and range of the system.

OSID Approvals

- UL
- ULC
- FM
- CSFM
- NF-SSI (AFNOR) *
- UKCA
- CE - CPR & EMC
- VdS
- BOSEC
- CCCF
- ActivFire
- VNIPO

Imager Lens Type	Field of View		Detection Range				Max. Number of Emitters
			Standard Power		High Power		
	Horizontal	Vertical	Min	Max	Min	Max	
10°	7°	4°	30m (98ft)	150m (492ft)	100m (328ft)	200m (656ft) / 180m (590ft)*	1

Emitter / Imager Dimensions

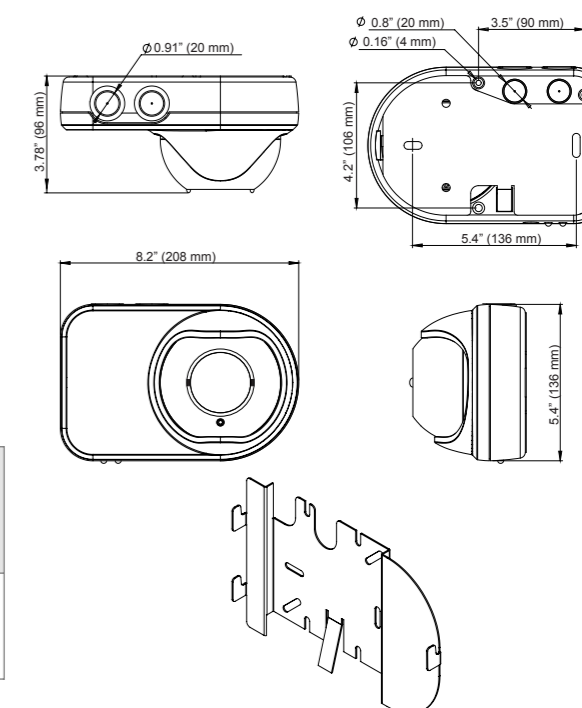



Remotest™

SAFETY AT THE HIGHEST LEVEL

Remotest™ by Fixfire® is a self-test module and backplate which supports the OSID Imager providing an industry first in self-testing OSID detection.

Remotest™ RT100 Explained

OSID is tested by placing a test filter in front of the unit at high-level. The Remotest™ RT100 self-test module incorporates a concealed arm which when remotely actuated is inserted in front of the detector, allowing both fault and fire functionality to be tested without any physical access to the detector being necessary.

The self-test function is either configured to operate via the Fire Alarm system itself or via browser-based controls accessed using the units built-in WiFi capabilities.

The Remotest™ RT100 self-test module requires a low voltage 24v dc supply and incorporates space to accommodate loop powered Fire Alarm modules for Gent by Honeywell and Apollo Fire Detection protocols.

Remotest™ RT100 mounting plate

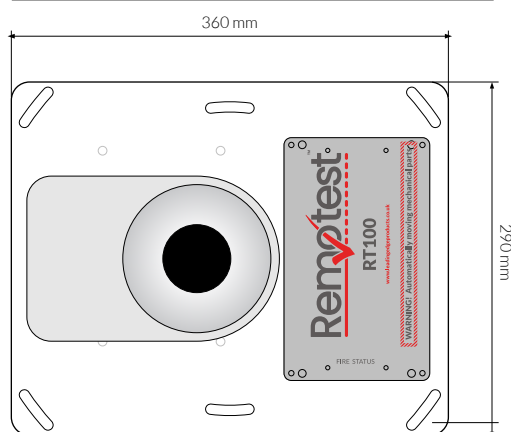

Remotest™ Chassis plate dimensions

Remotest™ by Fixfire is available in two formats as follows:

- Remotest™ standard. This is a complete assembly and incorporates OSID and the Remotest™ RT100 self-test module mounted on a chassis plate.
- Remotest™ chassis. This incorporates OSID mounted on the Remotest™ chassis plate and allows OSID to be installed ready for subsequent installation of the Remotest™ RT100 module.



Typical Remotest™ RT100 installation



Remotest™ RT100 in test-mode



Watch our Remotest video - *Transforming Fire Detection in Warehouses* at www.fixfire/remotest

OSID and Xtralis are trademarks of Garrett Thermal Systems Ltd a subsidiary of Honeywell International Inc.
 'Gent' is a trademark of Honeywell International Inc.
 'Apollo' is a trademark of Apollo Fire Detectors Ltd.

Visit our website
www.fixfire.co.uk



Head Office
 Mayflower House
 Bodmin Road
 Wyken, Coventry
 CV2 5DB

National Sales & Technology Centre
 Jubilee House
 Stenson Road
 Coalville
 LE67 4JP



your best alliance for compliance™

Visit our website www.fixfire.co.uk

[linkedin.com/company/fixfire](https://www.linkedin.com/company/fixfire)



Main Switchboard: 024 7661 6699 • Freephone: 08000 891999

Fixfire® is a trade mark of Avansys LLP registered in UK No OC384483

E-mail: sales@fixfire.co.uk • Website: www.fixfire.co.uk

© Fixfire® 2025