

Randaccio Wall Mirror, Round, Ø60

Designed by Jacques Adnet - 1950

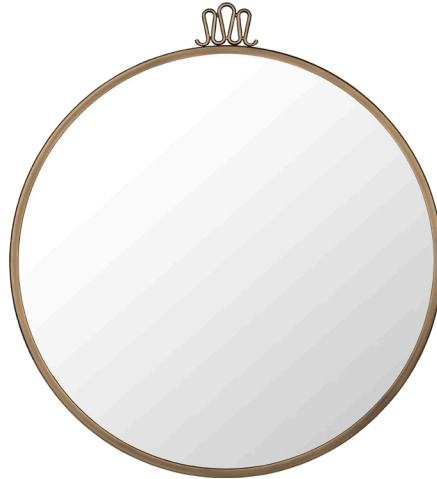

ITEM NUMBER	10994	
	Randaccio Wall Mirror, Round, Ø60	10014735

DESCRIPTION

One of Gio Ponti's signature designs is the Randaccio Mirror from 1925. Designed for his own home on Via Randaccio in Milano, his very first architectural project, the Randaccio Mirror decorated the walls in his bedroom on the 3rd floor together with other furniture designed for the apartment. The Randaccio Mirror unites elegance with simplicity and is characterised by its atypical crown-like detailing on the top, a detail used by Ponti in several of his works within design and art. The mirror, which comes in three different sizes, has references to its original time period but is able to add personality to every contemporary setting and enrich the decoration, whether it is a bedroom, bathroom, hallway or a dressing room.

Materials & Finishes

MIRROR FRAME Antique Brass



MATERIALS Steel, Glass

Dimensions

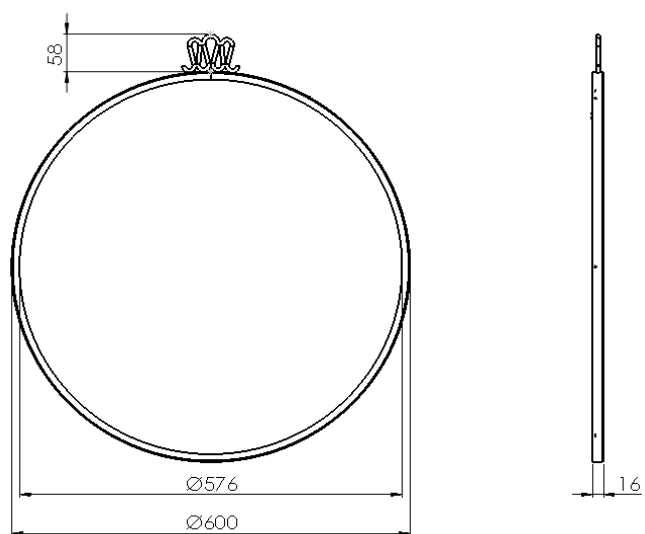

LENGTH \varnothing 60 cm / \varnothing 23.62 in

HEIGHT 66.2 cm / 26.06 in

MIRROR FRAME DEPTH 1.6 cm / 0.62 in

Weight

TOTAL WEIGHT 5 kg / 11.02 lbs

Packaging

NUMBER OF PARCELS 1

PACKAGING LENGTH 69.5 cm / 27.36 in

PACKAGING WIDTH 69.5 cm / 27.36 in

PACKAGING HEIGHT 8 cm / 17.71 in

PACKAGING WEIGHT 2 kg / 8.82 lbs

GROSS WEIGHT 7 kg / 15.57 lbs