

Bølling Tray Table Model 60

by Hans Bølling

BRDR. KRÜGER

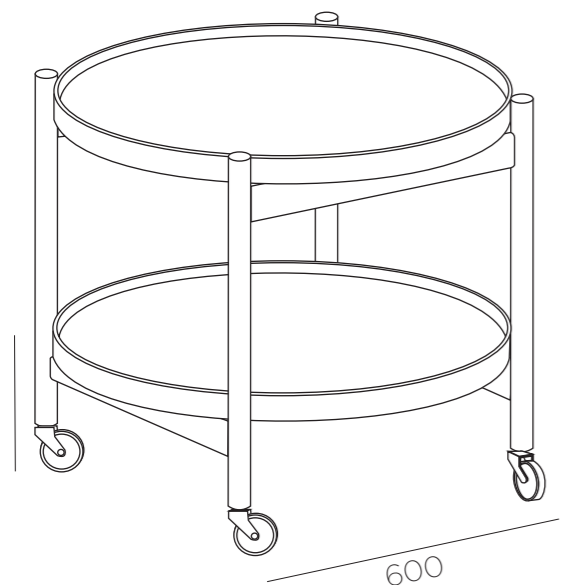

Oak, Oiled
BBO3-OOL











Beech, Oiled
BBO3-BOL



Fumed Oak, Oiled
BBO3-OFU



Walnut, Oiled
BBO3-WOL

| Tray Colour | # Reference |
|---|-------------|
|  BASE (Black / White) | BA |
|  STONE (Grey / Dark Grey) | ST |
|  EARTH (Beige / Brown) | EA |
|  LEAF (Green / Dark Green) | LE |
|  WATER (Blue / Dark Blue) | WA |
|  SUNNY (Cream / Yellow) | SU |
|  CLAY (Cognac / Black) | CL |
|  RED (Red / Black) | RE |

Dimensions

| | |
|-------------|--------------------|
| Diameter | Ø600 mm |
| Height | 520 mm |
| Tray Height | 25 mm |
| Box | 900 x 120 x 650 mm |
| Weight | 5,5 kg |

Responsibility

At Brdr. Krüger, sustainable product lifecycle considerations are at the heart of everything we do with focus on benefits for the environment, workers, and end-users. We source high-quality materials from certified sustainable forest management. The manufacturing processes run on low-emission hydropower and waste-to-energy solutions, achieving a near carbon-neutral effect and minimizing our reliance on fossil fuels. Our commitment to traditional craftsmanship and durable design ensures that our furniture is not only timeless but also built to last, contributing to sustainability for future generations.

Test and Certification

The wood is sourced from sustainably managed forests and certified by PEFC through independent third-party verification.

Meeting Regulations

The Clear Oil features a low VOC content and is fully compliant with EU regulations. This product contains no biocides, ensuring a natural and environmentally responsible finish. Worker safety is a high priority, with all processes conducted under controlled conditions in accordance with unions and national regulations.

Maintenance

Please see our Maintenance & Care instructions at

Easy Assembly

Its foldable design enables easy storage, transport and requires no tools for assembly. It is shipped flat-packed, reducing its environmental footprint.

Variants

The table's frame is offered in a variety of wood finishes, paired with a wide selection of reversible laminate trays—each featuring two carefully matched colors on opposite sides.

Materials, Process and Finishing

Crafted in Denmark using a combination of traditional woodworking techniques and modern precision manufacturing. The frame is made from solid European wood, carefully turned and assembled by hand to ensure structural integrity and lasting quality. The two reversible trays made from high-pressure laminate are mounted on a stable wooden frame. The wooden surfaces are treated with a protective oil finish, to enhance durability and highlight the natural grain.

Fumed Oak Process

For a deeper tone, the oak undergoes a traditional fuming process, where it is exposed to a small amount of ammonia vapors in a sealed environment for 20 hours. This reaction with the wood's natural tannins enhances the grain structure and deepens the color. As a natural, non-surface-based treatment, no dyes are used, preserving the wood's authentic character. Variations in hue may occur depending on the tannin content of each piece.

Craftsmanship Statement

We support and foster the Danish cultural heritage of craftsmanship by preserving and advancing the traditional techniques nurtured in our family workshop since **This commitment reflects** both the preservation of the craft and its evolution through the integration of new techniques, innovation, and design development.

Description

The Bølling Tray Table exemplifies the playful functionalism characteristic of the Danish Modern era. This versatile piece serves multiple purposes—functioning as a serving trolley, bar cart, bedside table, or side table—while maintaining a light and mobile design. The table features two reversible laminate trays, each side showcasing different colors for customizable aesthetics. The curated selection of laminate colors are featuring two complementary colors, which are carefully chosen to create soft contrasts and tone-in-tone harmony, thoughtfully matched to the natural hues of the wooden frame.