

& Tradition

Drip ^{HW115-HW117}

Hee Welling

2025



Drip^{HW115} Hee Welling 2025

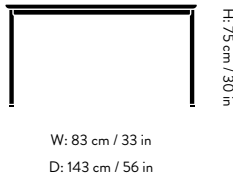

Product description

Dining table

Environment

Indoor

Material

Solid oak and oak veneer or solid walnut and walnut veneer, MDF, extruded aluminium in black. This product has not been treated with any biocides.

Production process

The table top is made of chipboard. Solid wood profiles are glued to the edges of the board, and veneer is then glued to the top of the board. The edges are milled to a rounded shape. Finally the table top is lacquered with a water-based clear lacquer. For the walnut variant, a stain is applied to achieve a uniform colour.

Dimensions

H: 75 cm / 30 in

W: 83 cm / 33 in

D: 143 cm / 56 in

Weight

25 kg

Strength, Durability and Safety Testing

EN Level 2 - Tables

Certifications



FSC® Mix 70%

Gliders

Plastic gliders as standard

Impact

- Uses FSC® certified wood, supporting responsible management of the world's forests.
- Uses water based lacquer, safer for indoor air quality.
- Designed for disassembly, making it easier to repair, renovate, pass on, and responsibly recycle at end of life.
- Uses aluminium, a lightweight, durable metal that is highly recyclable - able to be repurposed in another production cycle, reducing the demand for new material.

Manufacturer

Produced in Poland by Fabryka Mebli Zabroccy Sp. z o.o.

Cleaning Instructions

[Please see our Maintenance & Care instructions here](#)

→ Stock items

Oak with Black Base, Walnut with Black Base



→ Oak with Black Base



→ Walnut with Black Base



W: 83 cm / 33 in
D: 193 cm / 76 in

Drip^{HW116} Hee Welling 2025

Product description

Dining table

Environment

Indoor

Material

Solid oak and oak veneer or solid walnut and walnut veneer, MDF, extruded aluminium in black. This product has not been treated with any biocides.

Production process

The table top is made of chipboard. Solid wood profiles are glued to the edges of the board, and veneer is then glued to the top of the board. The edges are milled to a rounded shape. Finally the table top is lacquered with a water-based clear lacquer. For the walnut variant, a stain is applied to achieve a uniform colour.

Dimensions

H: 75 cm / 30 in
W: 83 cm / 33 in
D: 193 cm / 76 in

Weight

31 kg

Strength, Durability and Safety Testing

EN Level 2 - Tables

Certifications



FSC® Mix 70%

Gliders

Plastic gliders as standard

Impact

- Uses FSC® certified wood, supporting responsible management of the world's forests.
- Uses water based lacquer, safer for indoor air quality.
- Designed for disassembly, making it easier to repair, renovate, pass on, and responsibly recycle at end of life.
- Uses aluminium, a lightweight, durable metal that is highly recyclable - able to be repurposed in another production cycle, reducing the demand for new material.

Manufacturer

Produced in Poland by Fabryka Mebli Zabroccy Sp. z o.o.

Cleaning Instructions

[Please see our Maintenance & Care instructions here](#)

→ Stock items

Oak with Black Base, Walnut with Black Base



→ Oak with Black Base



→ Walnut with Black Base

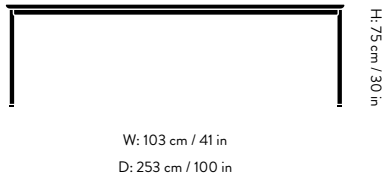

Drip^{HW117} Hee Welling 2025

Product description

Dining table

Environment

Indoor

Material

Solid oak and oak veneer or solid walnut and walnut veneer, MDF, extruded aluminium in black. This product has not been treated with any biocides.

Production process

The table top is made of chipboard. Solid wood profiles are glued to the edges of the board, and veneer is then glued to the top of the board. The edges are milled to a rounded shape. Finally the table top is lacquered with a water-based clear lacquer. For the walnut variant, a stain is applied to achieve a uniform colour.

Dimensions

H: 75 cm / 30 in
W: 103 cm / 41 in
D: 253 cm / 100 in

Weight

47.8 kg

Strength, Durability and Safety Testing

EN Level 2 - Tables

Certifications



FSC® Mix 70%

Gliders

Plastic gliders as standard

Impact

- Uses FSC® certified wood, supporting responsible management of the world's forests.
- Uses water based lacquer, safer for indoor air quality.
- Designed for disassembly, making it easier to repair, renovate, pass on, and responsibly recycle at end of life.
- Uses aluminium, a lightweight, durable metal that is highly recyclable - able to be repurposed in another production cycle, reducing the demand for new material.

Manufacturer

Produced in Poland by Fabryka Mebli Zabroccy Sp. z o.o.

Cleaning Instructions

[Please see our Maintenance & Care instructions here](#)

→ Stock items

Oak with Black Base, Walnut with Black Base



→ Oak with Black Base



→ Walnut with Black Base

Recycling & Disassembly

Drip HW115-HW117

RECYCLING

The Drip table is built to last, and we hope that your Drip will serve you for many years. The table top can be easily separated from its base. All metal and wooden parts can be separated and delivered to a suitable recycling station.

SPARE PARTS

To purchase spare parts for your Drip table, please write to our sales support team at with your query.

5 YEAR WARRANTY

&Tradition provides a 5-year warranty with every Drip table, which covers faults which were present at the time of purchase, or which have occurred as a result of a manufacturing defect. The warranty is valid from the date stated on the original invoice.

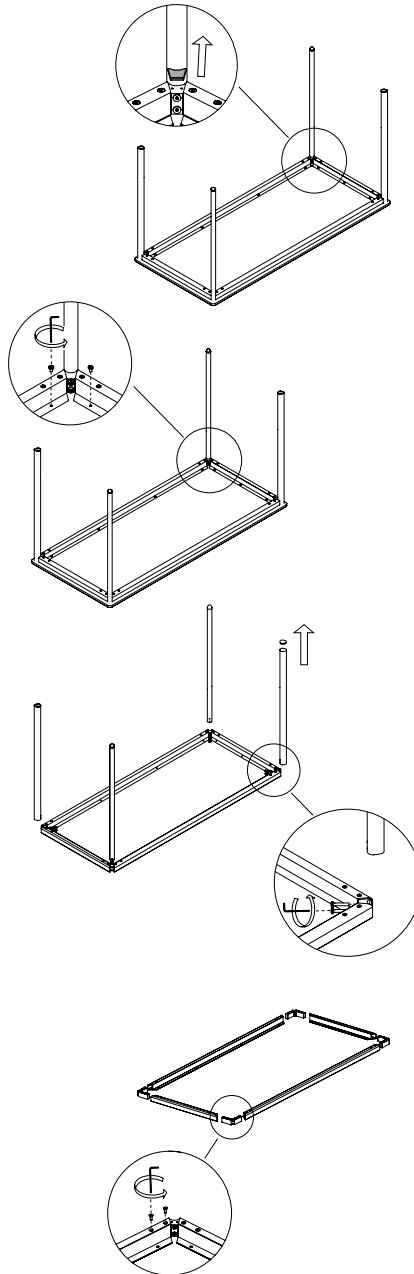

DISASSEMBLY

1. Place the table upside down on a soft, flat surface. Remove the cover components on each of the 4 corners.

2. Separate the tabletop from the frame by removing the screws located around the frame. Turn the screws counterclockwise to loosen them.

3. Next, detach the legs. To do this, remove the two screws facing diagonally outward on each corner. Afterward, remove the glider from each leg.

4. Separate all four corners from the frame elements by removing the screws connecting the parts.