

## Keen Shelving System, 2 Arches, 96, 6 shelves - Glass

Designed by Linda Korndal - 2025

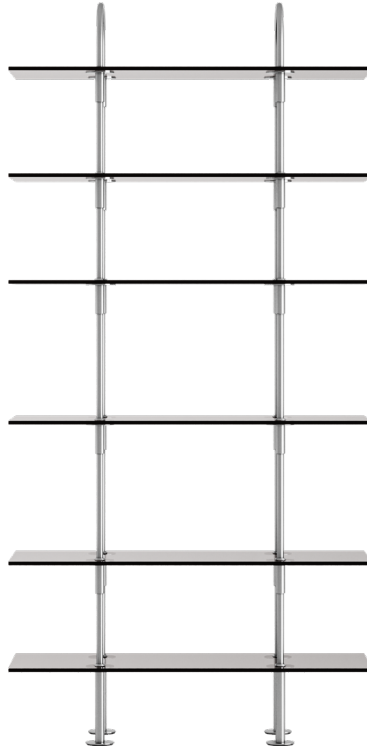

### ITEM NUMBER

Keen Shelving System, 2 Arches, 96, 6 shelves (Frame: Satin Stainless Steel, Shelves: Smoked Tempered Glass) - 10145115  
Keen Shelving System, 2 Arches, 96, 6 shelves (Frame: Black Brass, Shelves: Smoked Tempered Glass) - 10145117

### DESCRIPTION

Created for GUBI by Linda Korndal's studio, Toko Among Friends, Keen is a modular shelving system defined by architectural structure, expressive personality, and quiet adaptability. Designed to evolve with its user, Keen expands both vertically and laterally through an intuitive rod-and-bracket system that keeps the composition visually complete at every stage. With seven core modules, frame options in black brass or satin-polished stainless steel, and shelves in FSC-certified black-brown stained ash, FSC-certified ALPI veneer, or cool-gray stained glass, the system brings sculptural rhythm, material depth, and emotional resonance to homes, hospitality settings, and workspaces alike.

## Materials & Finishes

### FRAME

Satin Stainless Steel, Black Brass



### SHELVES

Smoke Tempered Glass



---

## Dimensions

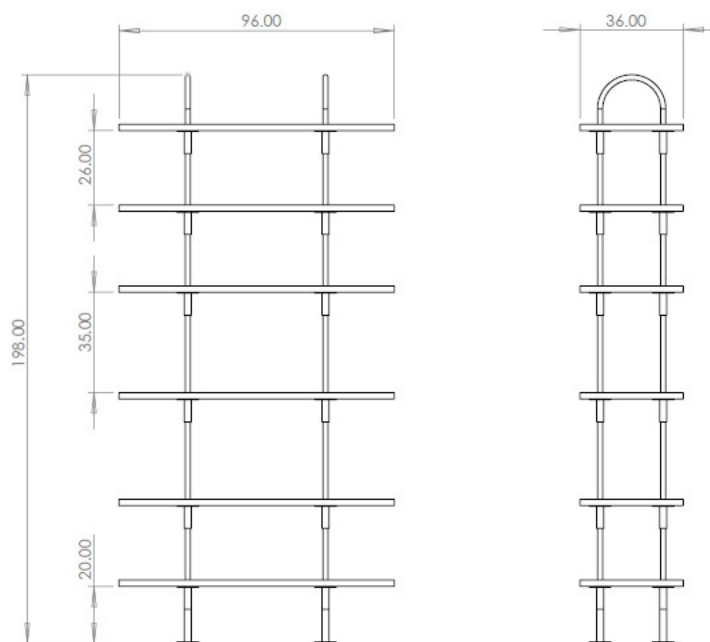

**WIDTH** 96 cm / 37.8 in

**DEPTH** 36 cm / 14.2 in

**HEIGHT** 198 cm / 78.0 in

---

## Weight

**TOTAL WEIGHT** 94 kg / 207.2 lbs

---

Number of parcels 7

**KEEN METAL COMPONENTS BOX S**

**PACKAGING LENGTH** 32.2 cm / 12.6 in

**PACKAGING WIDTH** 48.4 cm / 19.0 in

**PACKAGING HEIGHT** 51 cm / 20.0 in

**GROSS WEIGHT** 19 kg / 41.9 lbs

**KEEN SHELVING SYSTEM SHELF , 160X36CM**

**PACKAGING LENGTH** 104 cm / 40.9 in

**PACKAGING WIDTH** 44 cm / 17.3 in

**PACKAGING HEIGHT** 8.5 cm / 3.3 in

**GROSS WEIGHT** 12.5 kg / 25.6 lbs

---

Test & Certifications

FSC® C176589.

---

Mounting parts

**INCLUDED** Yes

---



## Keen Shelving System, 2 Arches, 96, 6 shelves - Veneer

Designed by Linda Korndal - 2025



### ITEM NUMBER

Keen Shelving System, 2 Arches, 96, 6 shelves (Frame: Satin Stainless Steel, Shelves: Brown/Black Ash Veneer) - 10143813  
Keen Shelving System, 2 Arches, 96, 6 shelves (Frame: Black Brass, Shelves: Brown/Black Ash Veneer) - 10145116  
Keen Shelving System, 2 Arches, 96, 6 shelves (Frame: Satin Stainless Steel, Shelves: ALPI Sottsass Gray Veneer) - 10145768  
Keen Shelving System, 2 Arches, 96, 6 shelves (Frame: Black Brass, Shelves: ALPI Sottsass Gray Veneer) - 10145769

### DESCRIPTION

Created for GUBI by Linda Korndal's studio, Toko Among Friends, Keen is a modular shelving system defined by architectural structure, expressive personality, and quiet adaptability. Designed to evolve with its user, Keen expands both vertically and laterally through an intuitive rod-and-bracket system that keeps the composition visually complete at every stage. With seven core modules, frame options in black brass or satin-polished stainless steel, and shelves in FSC-certified black-brown stained ash, FSC-certified ALPI veneer, or cool-gray stained glass, the system brings sculptural rhythm, material depth, and emotional resonance to homes, hospitality settings, and workspaces alike.

## Materials & Finishes

### FRAME

Satin Stainless Steel, Black Brass



### SHELVES

Brown/Black Ash Veneer, Alpi Sottsass Gray

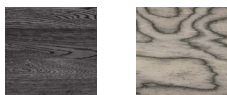

---

## Dimensions

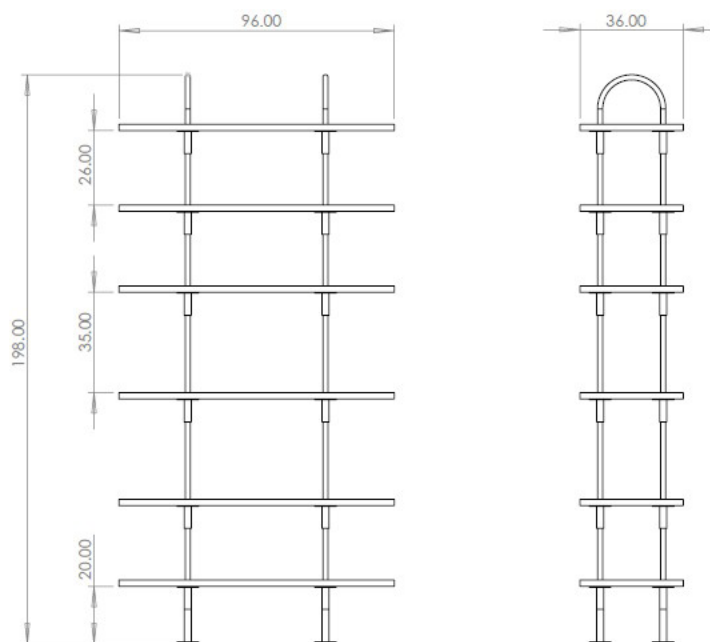

<b>WIDTH</b>	96 cm / 37.8 in
<b>DEPTH</b>	36 cm / 14.2 in
<b>HEIGHT</b>	198 cm / 78.0 in

---

## Weight

<b>TOTAL WEIGHT</b>	61 kg / 134.5 lbs
---------------------	-------------------

---

Number of parcels 7

**KEEN METAL COMPONENTS BOX S**

**PACKAGING LENGTH** 32.2 cm / 12.6 in

**PACKAGING WIDTH** 48.4 cm / 19.0 in

**PACKAGING HEIGHT** 51 cm / 20.0 in

**GROSS WEIGHT** 19 kg / 41.9 lbs

**KEEN SHELVING SYSTEM SHELF , 160X36CM**

**PACKAGING LENGTH** 104 cm / 40.9 in

**PACKAGING WIDTH** 44 cm / 17.3 in

**PACKAGING HEIGHT** 8.5 cm / 3.3 in

**GROSS WEIGHT** 7 kg / 15.4 lbs

---

Test & Certifications

FSC® C176589.

---

Mounting parts

**INCLUDED** Yes

---



## Keen Shelving System, 2 Arches, 160, 1 shelf & box

Designed by Linda Korndal - 2025



### ITEM NUMBER

Keen Shelving System, 2 Arches, 160, 1 shelf & box (Frame: Satin Stainless Steel, Shelves: Brown/Black Ash Veneer) - 10143812  
 Keen Shelving System, 2 Arches, 160, 1 shelf & box (Frame: Black Brass, Shelves: Brown/Black Ash Veneer) - 10145104  
 Keen Shelving System, 2 Arches, 160, 1 shelf & box (Frame: Satin Stainless Steel, Shelves: ALPI Sottsass Gray Veneer) - 10145760  
 Keen Shelving System, 2 Arches, 160, 1 shelf & box (Frame: Black Brass, Shelves: ALPI Sottsass Gray Veneer) - 10145761

### DESCRIPTION

Created for GUBI by Linda Korndal's studio, Toko Among Friends, Keen is a modular shelving system defined by architectural structure, expressive personality, and quiet adaptability. Designed to evolve with its user, Keen expands both vertically and laterally through an intuitive rod-and-bracket system that keeps the composition visually complete at every stage. With seven core modules, frame options in black brass or satin-polished stainless steel, and shelves in FSC-certified black-brown stained ash, FSC-certified ALPI veneer, or cool-gray stained glass, the system brings sculptural rhythm, material depth, and emotional resonance to homes, hospitality settings, and workspaces alike.

## Materials & Finishes

### FRAME

Satin Stainless Steel, Black Brass



### SHELVES

Brown/Black Ash Veneer, Alpi Sottsass Gray

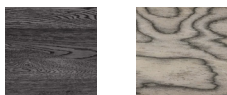

---

## Dimensions

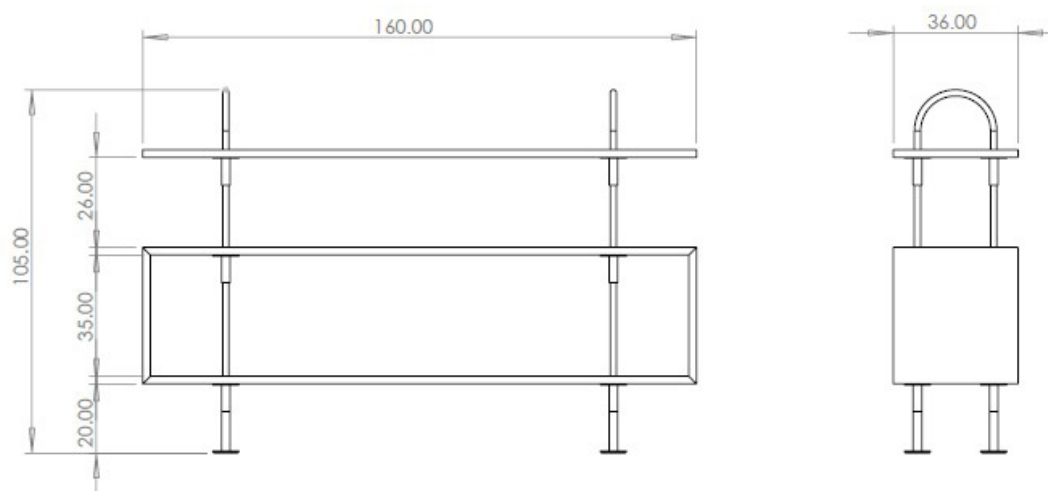

**WIDTH** 160 cm / 63.0 in

**DEPTH** 36 cm / 14.2 in

**HEIGHT** 105 cm / 41.3 in

---

## Weight

**TOTAL WEIGHT** 48 kg / 105.8 lbs

---

Number of parcels 3

**KEEN METAL COMPONENTS BOX S**

**PACKAGING LENGTH** 32.2 cm / 12.6 in

**PACKAGING WIDTH** 48.4 cm / 19.0 in

**PACKAGING HEIGHT** 51 cm / 20.0 in

**GROSS WEIGHT** 12 kg / 26.5 lbs

**KEEN SHELVING SYSTEM SHELF , 160X36CM**

**PACKAGING LENGTH** 168 cm / 66.1 in

**PACKAGING WIDTH** 44 cm / 17.3 in

**PACKAGING HEIGHT** 8.5 cm / 3.3 in

**GROSS WEIGHT** 12 kg / 26.5 lbs

**KEEN SHELVING SYSTEM BOX SHELF**

**PACKAGING LENGTH** 166.5 cm / 65.5 in

**PACKAGING WIDTH** 42.5 cm / 16.7 in

**PACKAGING HEIGHT** 47 cm / 18.5 in

**GROSS WEIGHT** 24 kg / 53.0 lbs

---

Test & Certifications

**FSC® C176589.**

---

Mounting parts

**INCLUDED** Yes

---



---

## Keen Shelving System, 2 Arches, 160, 3 Shelves - Glass

Designed by Linda Korndal - 2025

---

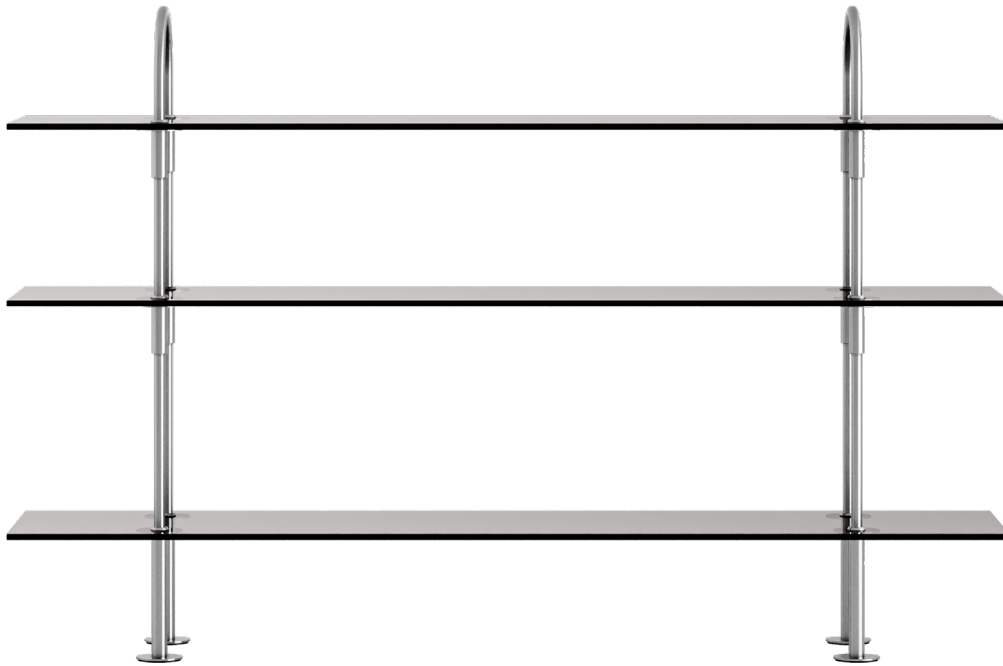

---

### ITEM NUMBER

Keen Shelving System, 2 Arches, 160, 3 shelves (Frame: Satin Stainless Steel, Shelves: Smoked Tempered Glass) - 10145106  
Keen Shelving System, 2 Arches, 160, 3 shelves (Frame: Black Brass, Shelves: Smoked Tempered Glass) - 10145108

### DESCRIPTION

Created for GUBI by Linda Korndal's studio, Toko Among Friends, Keen is a modular shelving system defined by architectural structure, expressive personality, and quiet adaptability. Designed to evolve with its user, Keen expands both vertically and laterally through an intuitive rod-and-bracket system that keeps the composition visually complete at every stage. With seven core modules, frame options in black brass or satin-polished stainless steel, and shelves in FSC-certified black-brown stained ash, FSC-certified ALPI veneer, or cool-gray stained glass, the system brings sculptural rhythm, material depth, and emotional resonance to homes, hospitality settings, and workspaces alike.

---

## Materials & Finishes

### FRAME

Satin Stainless Steel, Black Brass



### SHELVES

Smoke Tempered Glass



## Dimensions

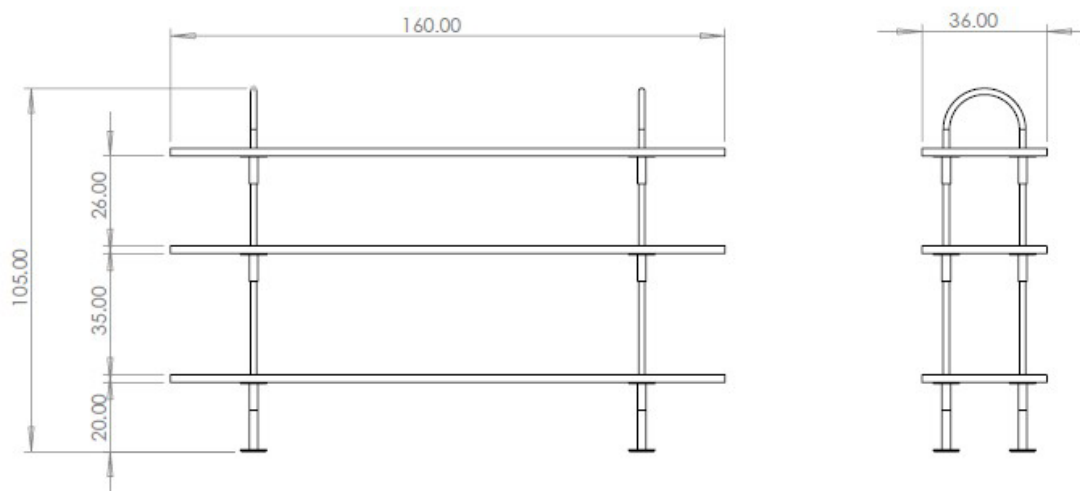

**WIDTH** 160 cm / 63.0 in

**DEPTH** 36 cm / 14.2 in

**HEIGHT** 105 cm / 41.3 in

## Weight

**TOTAL WEIGHT** 66 kg / 145.5 lbs

Number of parcels 4

**KEEN METAL COMPONENTS BOX S**

**PACKAGING LENGTH** 32.2 cm / 12.6 in

**PACKAGING WIDTH** 48.4 cm / 19.0 in

**PACKAGING HEIGHT** 51 cm / 20.0 in

**GROSS WEIGHT** 12 kg / 26.5 lbs

**KEEN SHELVING SYSTEM SHELF , 160X36CM**

**PACKAGING LENGTH** 168 cm / 66.1 in

**PACKAGING WIDTH** 44 cm / 17.3 in

**PACKAGING HEIGHT** 8.5 cm / 3.3 in

**GROSS WEIGHT** 18 kg / 39.7 lbs

---

Test & Certifications

FSC® C176589.

---

Mounting parts

**INCLUDED** Yes

---



## Keen Shelving System, 2 Arches, 160, 3 Shelves - Veneer

Designed by Linda Korndal - 2025

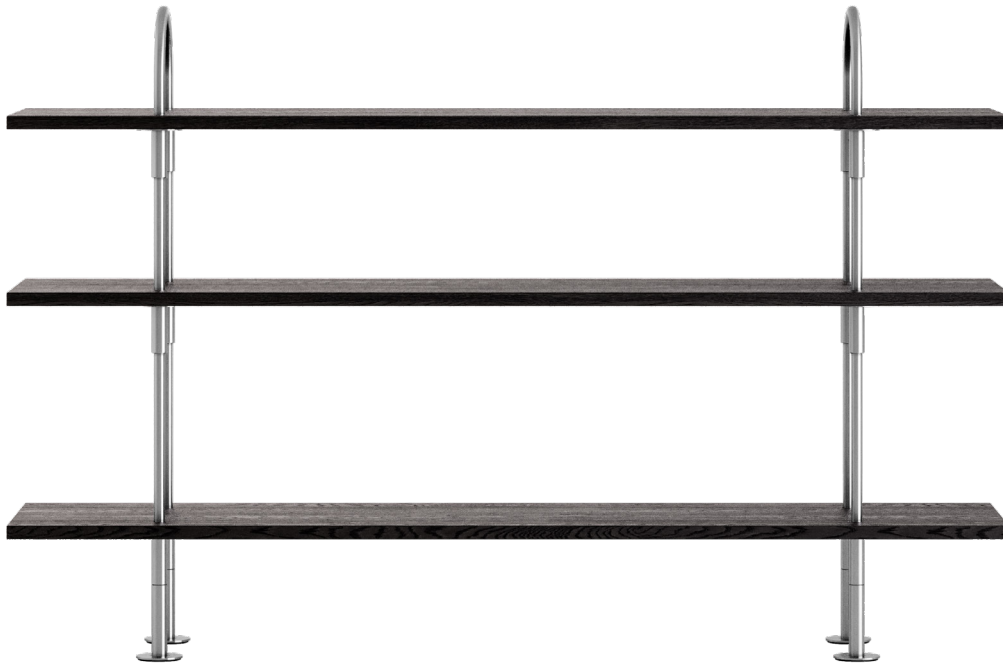

### ITEM NUMBER

Keen Shelving System, 2 Arches, 160, 3 shelves (Frame: Satin Stainless Steel, Shelves: Brown/Black Ash Veneer) - 10143807 ;  
Keen Shelving System, 2 Arches, 160, 3 shelves (Frame: Black Brass, Shelves: Brown/Black Ash Veneer) - 10145107  
Keen Shelving System, 2 Arches, 160, 3 shelves (Frame: Satin Stainless Steel, Shelves: ALPI Sottsass Gray Veneer) - 10145762  
Keen Shelving System, 2 Arches, 160, 3 shelves (Frame: Black Brass, Shelves: ALPI Sottsass Gray Veneer) - 10145763

### DESCRIPTION

Created for GUBI by Linda Korndal's studio, Toko Among Friends, Keen is a modular shelving system defined by architectural structure, expressive personality, and quiet adaptability. Designed to evolve with its user, Keen expands both vertically and laterally through an intuitive rod-and-bracket system that keeps the composition visually complete at every stage. With seven core modules, frame options in black brass or satin-polished stainless steel, and shelves in FSC-certified black-brown stained ash, FSC-certified ALPI veneer, or cool-gray stained glass, the system brings sculptural rhythm, material depth, and emotional resonance to homes, hospitality settings, and workspaces alike.

## Materials & Finishes

### FRAME

Satin Stainless Steel, Black Brass



### SHELVES

Brown/Black Ash Veneer, Alpi Sottsass Gray

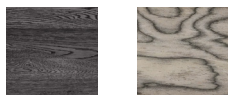

---

## Dimensions

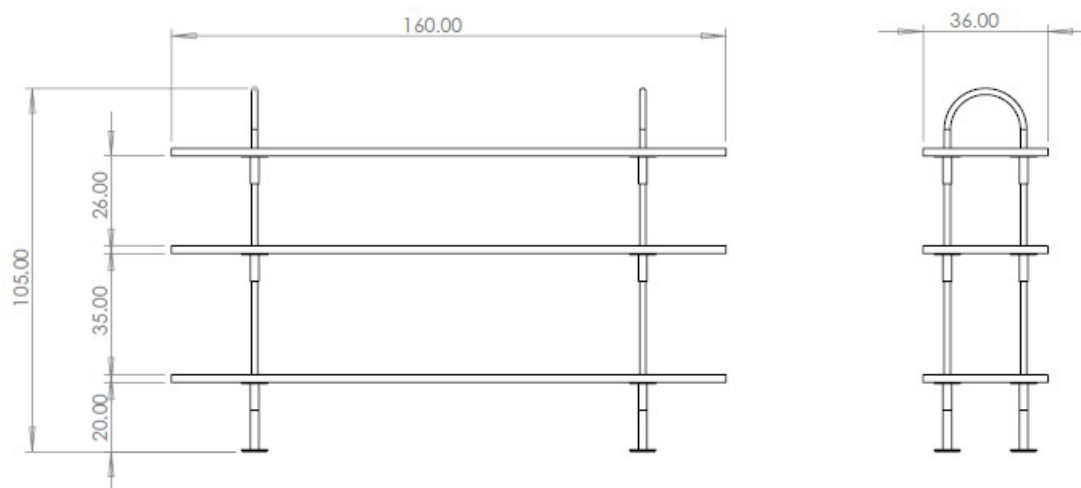

**WIDTH** 160 cm / 63.0 in

**DEPTH** 36 cm / 14.2 in

**HEIGHT** 105 cm / 41.3 in

---

## Weight

**TOTAL WEIGHT** 48 kg / 105.8 lbs

---

Number of parcels 4

**KEEN METAL COMPONENTS BOX S**

**PACKAGING LENGTH** 32.2 cm / 12.6 in

**PACKAGING WIDTH** 48.4 cm / 19.0 in

**PACKAGING HEIGHT** 51 cm / 20.0 in

**GROSS WEIGHT** 12 kg / 26.5 lbs

**KEEN SHELVING SYSTEM SHELF , 160X36CM**

**PACKAGING LENGTH** 168 cm / 66.1 in

**PACKAGING WIDTH** 44 cm / 17.3 in

**PACKAGING HEIGHT** 8.5 cm / 3.3 in

**GROSS WEIGHT** 12 kg / 26.5 lbs

---

Test & Certifications

FSC® C176589.

---

Mounting parts

**INCLUDED** Yes

---



## Keen Shelving System, 2 Arches, 160, 4 shelves & box

Designed by Linda Korndal - 2025



### ITEM NUMBER

Keen Shelving System, 2 Arches, 160, 4 shelves & box (Frame: Satin Stainless Steel, Shelves: Brown/Black Ash Veneer) - 10143816  
 Keen Shelving System, 2 Arches, 160, 4 shelves & box (Frame: Black Brass, Shelves: Brown/Black Ash Veneer) - 10145110  
 Keen Shelving System, 2 Arches, 160, 4 shelves & box (Frame: Satin Stainless Steel, Shelves: ALPI Sottsass Gray Veneer) - 10145764  
 Keen Shelving System, 2 Arches, 160, 4 shelves & box (Frame: Black Brass, Shelves: ALPI Sottsass Gray Veneer) - 10145765

### DESCRIPTION

Created for GUBI by Linda Korndal's studio, Toko Among Friends, Keen is a modular shelving system defined by architectural structure, expressive personality, and quiet adaptability. Designed to evolve with its user, Keen expands both vertically and laterally through an intuitive rod-and-bracket system that keeps the composition visually complete at every stage. With seven core modules, frame options in black brass or satin-polished stainless steel, and shelves in FSC-certified black-brown stained ash, FSC-certified ALPI veneer, or cool-gray stained glass, the system brings sculptural rhythm, material depth, and emotional resonance to homes, hospitality settings, and workspaces alike.

## Materials & Finishes

### FRAME

Satin Stainless Steel, Black Brass



### SHELVES

Brown/Black Ash Veneer, Alpi Sottsass Gray

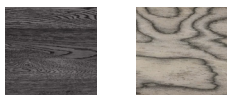

---

## Dimensions

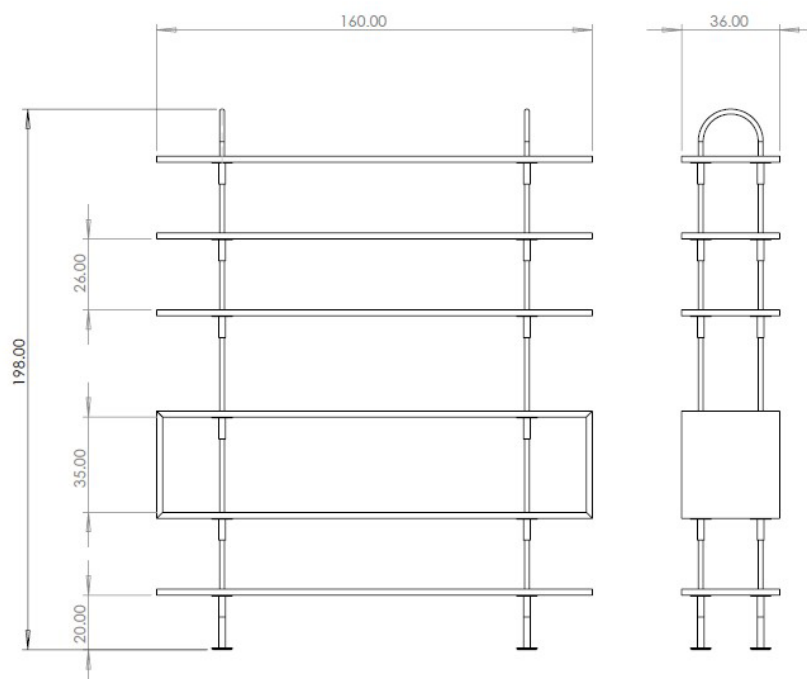

**WIDTH** 160 cm / 63.0 in

**DEPTH** 36 cm / 14.2 in

**HEIGHT** 198 cm / 78.0 in

---

## Weight

**TOTAL WEIGHT** 91 kg / 200.6 lbs

---

Number of parcels 6

**KEEN METAL COMPONENTS BOX S**

**PACKAGING LENGTH** 32.2 cm / 12.6 in

**PACKAGING WIDTH** 48.4 cm / 19.0 in

**PACKAGING HEIGHT** 51 cm / 20.0 in

**GROSS WEIGHT** 19 kg / 41.9 lbs

**KEEN SHELVING SYSTEM SHELF , 160X36CM**

**PACKAGING LENGTH** 168 cm / 66.1 in

**PACKAGING WIDTH** 44 cm / 17.3 in

**PACKAGING HEIGHT** 8.5 cm / 3.3 in

**GROSS WEIGHT** 12 kg / 26.5 lbs

**KEEN SHELVING SYSTEM BOX SHELF**

**PACKAGING LENGTH** 166.5 cm / 65.5 in

**PACKAGING WIDTH** 42.5 cm / 16.7 in

**PACKAGING HEIGHT** 47 cm / 18.5 in

**GROSS WEIGHT** 24 kg / 53.0 lbs

---

Test & Certifications

**FSC® C176589.**

---

Mounting parts

**INCLUDED** Yes

---



---

## Keen Shelving System, 2 Arches, 160, 6 shelves - Glass

Designed by Linda Korndal - 2025

---

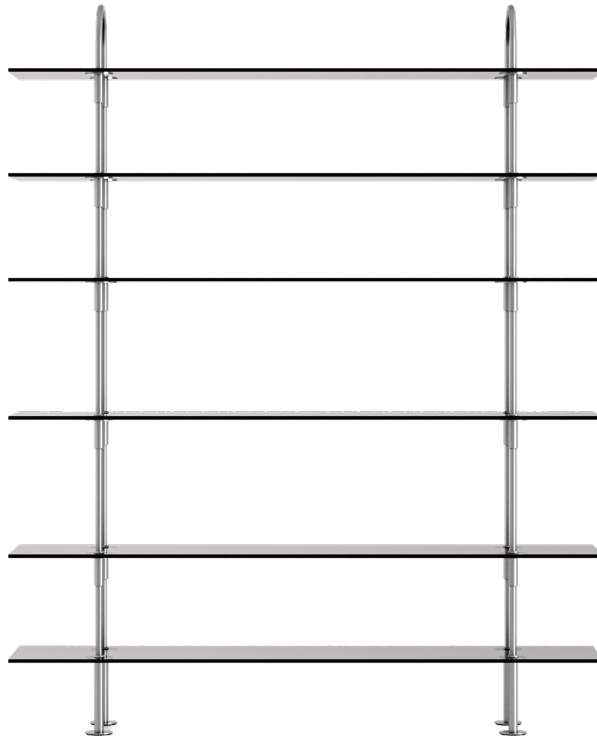

---

### ITEM NUMBER

Keen Shelving System, 2 Arches, 160, 6 shelves (Frame: Satin Stainless Steel, Shelves: Smoked Tempered Glass) - 10145112  
Keen Shelving System, 2 Arches, 160, 6 shelves (Frame: Black Brass, Shelves: Smoked Tempered Glass) - 10145114

### DESCRIPTION

Created for GUBI by Linda Korndal's studio, Toko Among Friends, Keen is a modular shelving system defined by architectural structure, expressive personality, and quiet adaptability. Designed to evolve with its user, Keen expands both vertically and laterally through an intuitive rod-and-bracket system that keeps the composition visually complete at every stage. With seven core modules, frame options in black brass or satin-polished stainless steel, and shelves in FSC-certified black-brown stained ash, FSC-certified ALPI veneer, or cool-gray stained glass, the system brings sculptural rhythm, material depth, and emotional resonance to homes, hospitality settings, and workspaces alike.

---

## Materials & Finishes

### FRAME

Satin Stainless Steel, Black Brass



### SHELVES

Smoke Tempered Glass



## Dimensions

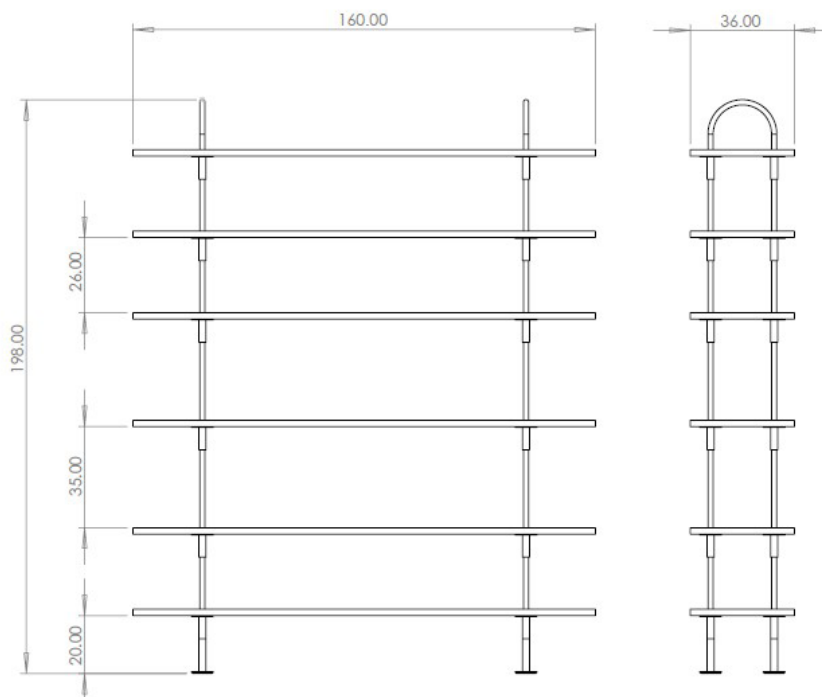

**WIDTH** 160 cm / 63.0 in

**DEPTH** 36 cm / 14.2 in

**HEIGHT** 198 cm / 78.0 in

## Weight

**TOTAL WEIGHT** 127 kg / 258.6 lbs

Number of parcels 7

**KEEN METAL COMPONENTS BOX S**

**PACKAGING LENGTH** 32.2 cm / 12.6 in

**PACKAGING WIDTH** 48.4 cm / 19.0 in

**PACKAGING HEIGHT** 51 cm / 20.0 in

**GROSS WEIGHT** 19 kg / 41.9 lbs

**KEEN SHELVING SYSTEM SHELF , 160X36CM**

**PACKAGING LENGTH** 168 cm / 66.1 in

**PACKAGING WIDTH** 44 cm / 17.3 in

**PACKAGING HEIGHT** 8.5 cm / 3.3 in

**GROSS WEIGHT** 18 kg / 39.7 lbs

---

Test & Certifications

FSC® C176589.

---

Mounting parts

**INCLUDED** Yes

---



## Keen Shelving System, 2 Arches, 160, 6 shelves - Veneer

Designed by Linda Korndal - 2025



### ITEM NUMBER

Keen Shelving System, 2 Arches, 160, 6 shelves (Frame: Satin Stainless Steel, Shelves: Brown/Black Ash Veneer) - 10143815  
Keen Shelving System, 2 Arches, 160, 6 shelves (Frame: Black Brass, Shelves: Brown/Black Ash Veneer) - 10145113  
Keen Shelving System, 2 Arches, 160, 6 shelves (Frame: Satin Stainless Steel, Shelves: ALPI Sottsass Gray Veneer) - 10145766  
Keen Shelving System, 2 Arches, 160, 6 shelves (Frame: Black Brass, Shelves: ALPI Sottsass Gray Veneer) - 10145767

### DESCRIPTION

Created for GUBI by Linda Korndal's studio, Toko Among Friends, Keen is a modular shelving system defined by architectural structure, expressive personality, and quiet adaptability. Designed to evolve with its user, Keen expands both vertically and laterally through an intuitive rod-and-bracket system that keeps the composition visually complete at every stage. With seven core modules, frame options in black brass or satin-polished stainless steel, and shelves in FSC-certified black-brown stained ash, FSC-certified ALPI veneer, or cool-gray stained glass, the system brings sculptural rhythm, material depth, and emotional resonance to homes, hospitality settings, and workspaces alike.

## Materials & Finishes

### FRAME

Satin Stainless Steel, Black Brass



### SHELVES

Brown/Black Ash Veneer, Alpi Sottsass Gray

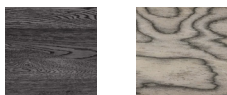

---

## Dimensions

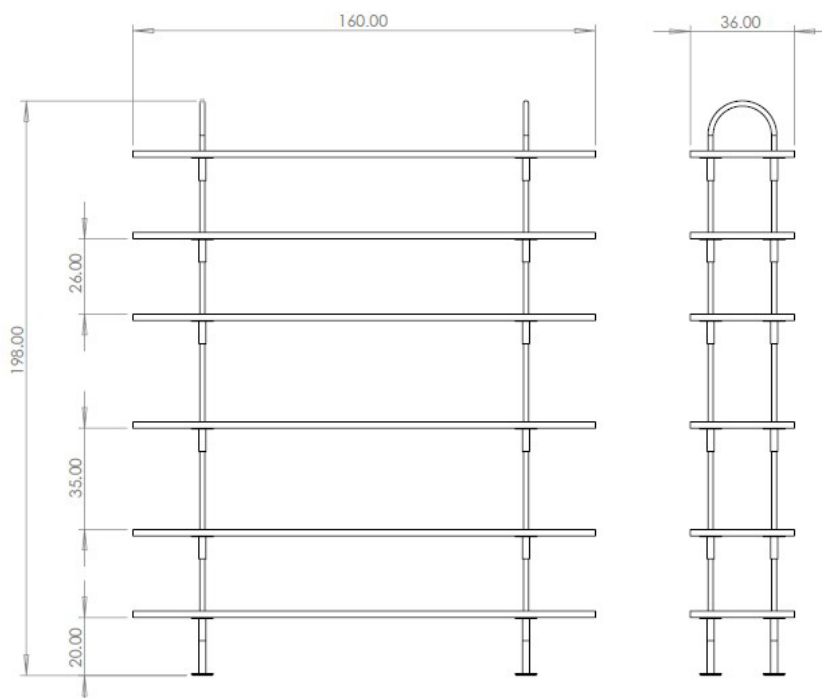

**WIDTH** 160 cm / 63.0 in

**DEPTH** 36 cm / 14.2 in

**HEIGHT** 198 cm / 78.0 in

---

## Weight

**TOTAL WEIGHT** 91 kg / 200.6 lbs

---

Number of parcels 7

**KEEN METAL COMPONENTS BOX S**

**PACKAGING LENGTH** 32.2 cm / 12.6 in

**PACKAGING WIDTH** 48.4 cm / 19.0 in

**PACKAGING HEIGHT** 51 cm / 20.0 in

**GROSS WEIGHT** 19 kg / 41.9 lbs

**KEEN SHELVING SYSTEM SHELF , 160X36CM**

**PACKAGING LENGTH** 168 cm / 66.1 in

**PACKAGING WIDTH** 44 cm / 17.3 in

**PACKAGING HEIGHT** 8.5 cm / 3.3 in

**GROSS WEIGHT** 12 kg / 26.5 lbs

---

Test & Certifications

FSC® C176589.

---

Mounting parts

**INCLUDED** Yes

---



---

## Keen Shelving System, 3 Arches, 208, 3 shelves - Glass

Designed by Linda Korndal - 2025

---

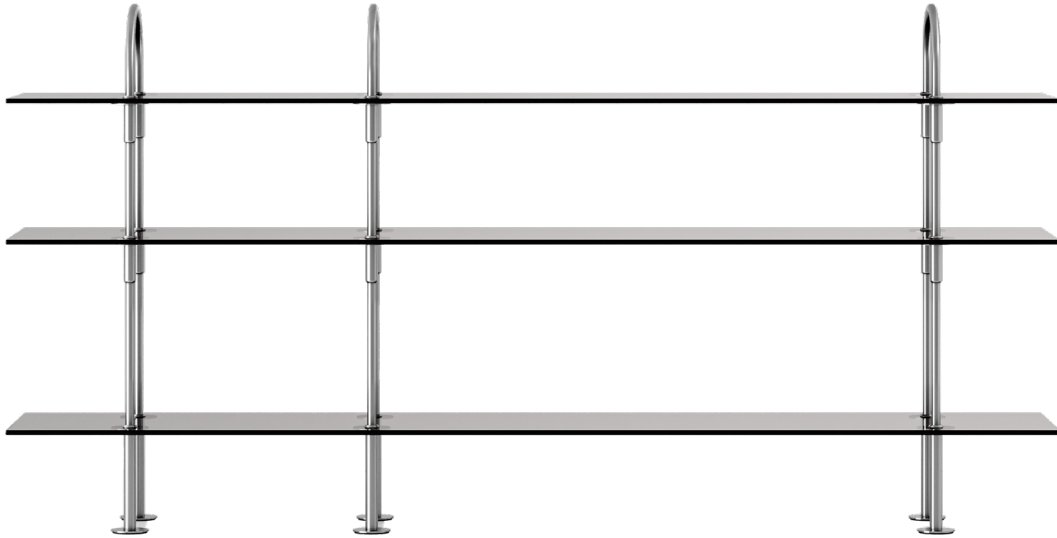

---

### ITEM NUMBER

Keen Shelving System, 3 Arches, 208, 3 shelves (Frame: Satin Stainless Steel, Shelves: Smoked Tempered Glass) - 10145118  
Keen Shelving System, 3 Arches, 208, 3 shelves (Frame: Black Brass, Shelves: Smoked Tempered Glass) - 10145120

### DESCRIPTION

Created for GUBI by Linda Korndal's studio, Toko Among Friends, Keen is a modular shelving system defined by architectural structure, expressive personality, and quiet adaptability. Designed to evolve with its user, Keen expands both vertically and laterally through an intuitive rod-and-bracket system that keeps the composition visually complete at every stage. With seven core modules, frame options in black brass or satin-polished stainless steel, and shelves in FSC-certified black-brown stained ash, FSC-certified ALPI veneer, or cool-gray stained glass, the system brings sculptural rhythm, material depth, and emotional resonance to homes, hospitality settings, and workspaces alike.

---

## Materials & Finishes

### FRAME

Satin Stainless Steel, Black Brass



### SHELVES

Smoked Tempered Glass



---

## Dimensions

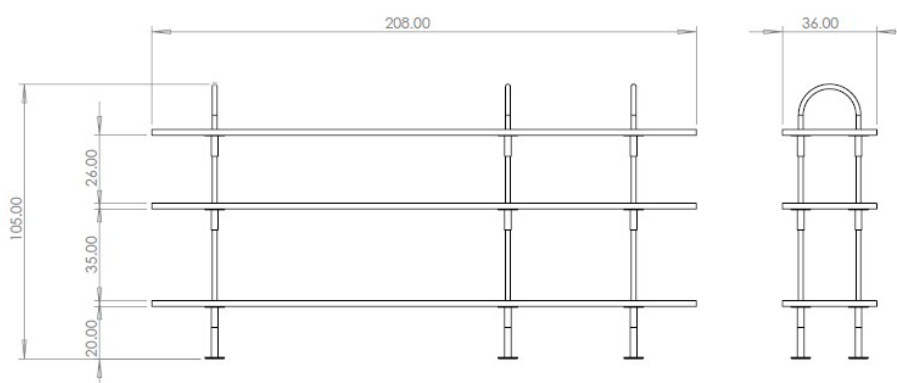

**WIDTH** 208 cm / 81.9 in

**DEPTH** 36 cm / 14.2 in

**HEIGHT** 105 cm / 41.3 in

---

## Weight

**TOTAL WEIGHT** 87.0 kg / 191.8 lbs

---

Number of parcels 4

**KEEN METAL COMPONENTS BOX M**

**PACKAGING LENGTH** 48.4 cm / 19.0 in

**PACKAGING WIDTH** 48.4 cm / 19.0 in

**PACKAGING HEIGHT** 51 cm / 20.0 in

**GROSS WEIGHT** 16.5 kg / 36.4 lbs

**KEEN SHELVING SYSTEM SHELF , 208X36CM**

**PACKAGING LENGTH** 216 cm / 85.0 in

**PACKAGING WIDTH** 44 cm / 17.3 in

**PACKAGING HEIGHT** 8.5 cm / 3.3 in

**GROSS WEIGHT** 23.5 kg / 31.3 lbs

---

Test & Certifications

**FSC® C176589.**

---

Mounting parts

**INCLUDED** Yes

---



## Keen Shelving System, 3 Arches, 208, 3 shelves - Veneer

Designed by Linda Korndal - 2025



### ITEM NUMBER

Keen Shelving System, 3 Arches, 208, 3 shelves (Frame: Satin Stainless Steel, Shelves: Brown/Black Ash Veneer) - 10143817  
Keen Shelving System, 3 Arches, 208, 3 shelves (Frame: Black Brass, Shelves: Brown/Black Ash Veneer) - 10145119  
Keen Shelving System, 3 Arches, 208, 3 shelves (Frame: Satin Stainless Steel, Shelves: ALPI Sottsass Gray Veneer) - 10145770  
Keen Shelving System, 3 Arches, 208, 3 shelves (Frame: Black Brass, Shelves: ALPI Sottsass Gray Veneer) - 10145771

### DESCRIPTION

Created for GUBI by Linda Korndal's studio, Toko Among Friends, Keen is a modular shelving system defined by architectural structure, expressive personality, and quiet adaptability. Designed to evolve with its user, Keen expands both vertically and laterally through an intuitive rod-and-bracket system that keeps the composition visually complete at every stage. With seven core modules, frame options in black brass or satin-polished stainless steel, and shelves in FSC-certified black-brown stained ash, FSC-certified ALPI veneer, or cool-gray stained glass, the system brings sculptural rhythm, material depth, and emotional resonance to homes, hospitality settings, and workspaces alike.

## Materials & Finishes

### FRAME

Satin Stainless Steel, Black Brass



### SHELVES

Brown/Black Ash Veneer, Alpi Sottsass Gray

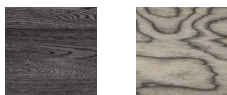

---

## Dimensions

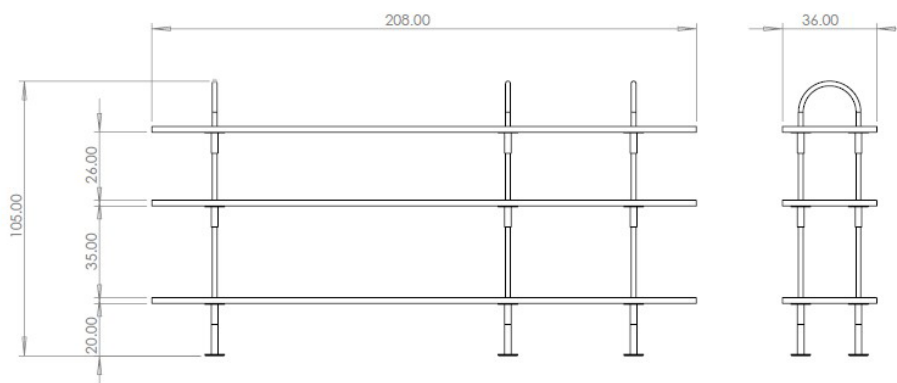

**WIDTH** 208 cm / 81.9 in

**DEPTH** 36 cm / 14.2 in

**HEIGHT** 105 cm / 41.3 in

---

## Weight

**TOTAL WEIGHT** 59.1 kg / 130.3 lbs

---

Number of parcels 4

**KEEN METAL COMPONENTS BOX M**

**PACKAGING LENGTH** 48.4 cm / 19.0 in

**PACKAGING WIDTH** 48.4 cm / 19.0 in

**PACKAGING HEIGHT** 51 cm / 20.0 in

**GROSS WEIGHT** 16.5 kg / 36.4 lbs

**KEEN SHELVING SYSTEM SHELF , 208X36CM**

**PACKAGING LENGTH** 216 cm / 85.0 in

**PACKAGING WIDTH** 44 cm / 17.3 in

**PACKAGING HEIGHT** 8.5 cm / 3.3 in

**GROSS WEIGHT** 14.2 kg / 31.3 lbs

---

Test & Certifications

FSC® C176589.

---

Mounting parts

**INCLUDED** Yes

---



## Keen Shelving System, 3 Arches, 208, 6 shelves - Glass

Designed by Linda Korndal - 2025

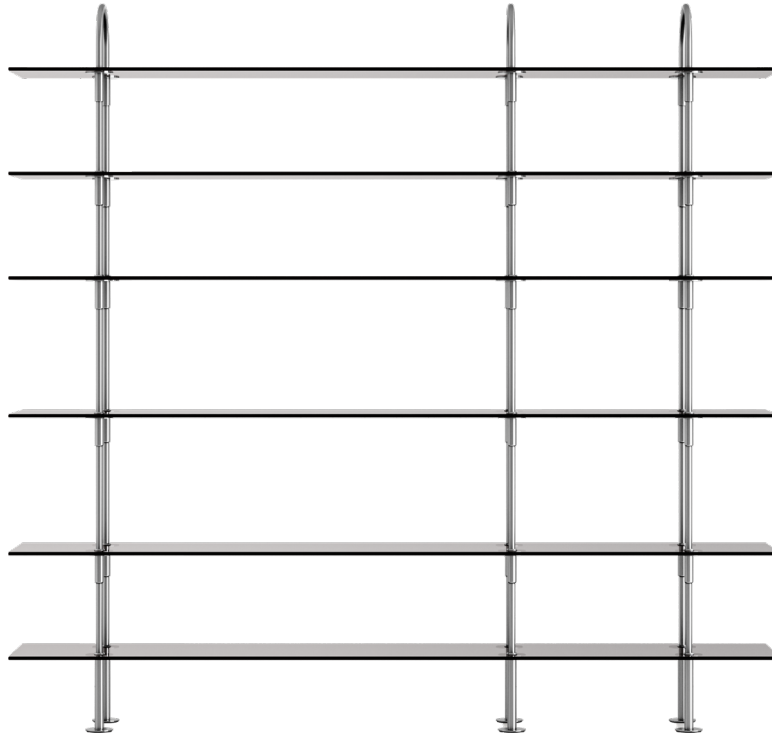

### ITEM NUMBER

Keen Shelving System, 3 Arches, 208, 6 shelves (Frame: Satin Stainless Steel, Shelves: Smoked Tempered Glass) - 10145121  
Keen Shelving System, 3 Arches, 208, 6 shelves (Frame: Black Brass, Shelves: Smoked Tempered Glass) - 10145123

### DESCRIPTION

Created for GUBI by Linda Korndal's studio, Toko Among Friends, Keen is a modular shelving system defined by architectural structure, expressive personality, and quiet adaptability. Designed to evolve with its user, Keen expands both vertically and laterally through an intuitive rod-and-bracket system that keeps the composition visually complete at every stage. With seven core modules, frame options in black brass or satin-polished stainless steel, and shelves in FSC-certified black-brown stained ash, FSC-certified ALPI veneer, or cool-gray stained glass, the system brings sculptural rhythm, material depth, and emotional resonance to homes, hospitality settings, and workspaces alike.

## Materials & Finishes

### FRAME

Satin Stainless Steel, Black Brass



### SHELVES

Smoked Tempered Glass



## Dimensions

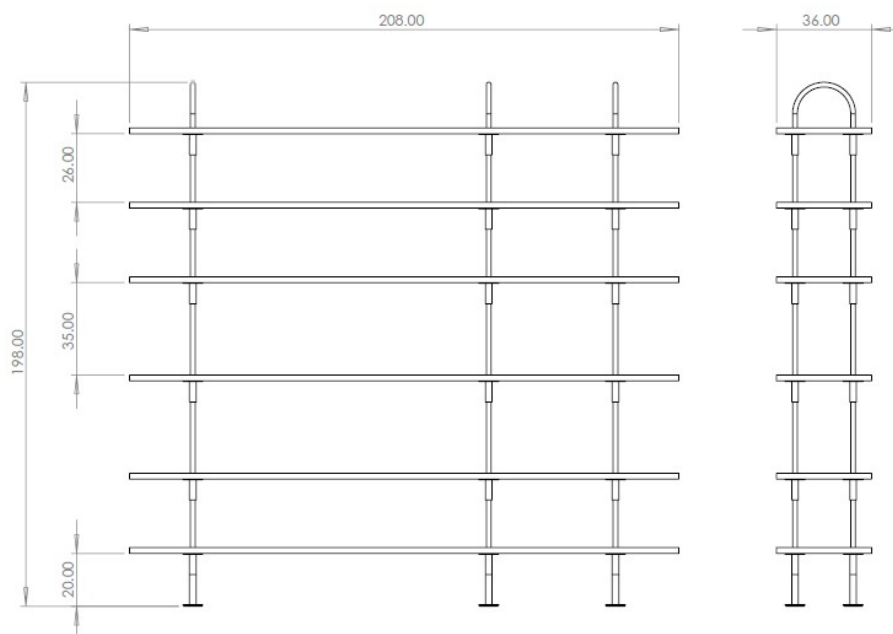

**WIDTH** 208 cm / 81.9 in

**DEPTH** 36 cm / 14.2 in

**HEIGHT** 198 cm / 78.0 in

## Weight

**TOTAL WEIGHT** 168.5 kg / 371.5 lbs

Number of parcels 7

**KEEN METAL COMPONENTS BOX M**

**PACKAGING LENGTH** 48.4 cm / 19.0 in

**PACKAGING WIDTH** 48.4 cm / 19.0 in

**PACKAGING HEIGHT** 51 cm / 20.0 in

**GROSS WEIGHT** 27.5 kg / 60.6 lbs

**KEEN SHELVING SYSTEM SHELF , 208X36CM**

**PACKAGING LENGTH** 216 cm / 85.0 in

**PACKAGING WIDTH** 44 cm / 17.3 in

**PACKAGING HEIGHT** 8.5 cm / 3.3 in

**GROSS WEIGHT** 23.5 kg / 51.8 lbs

---

Test & Certifications

FSC® C176589.

---

Mounting parts

**INCLUDED** Yes

---



## Keen Shelving System, 3 Arches, 208, 6 shelves - Veneer

Designed by Linda Korndal - 2025

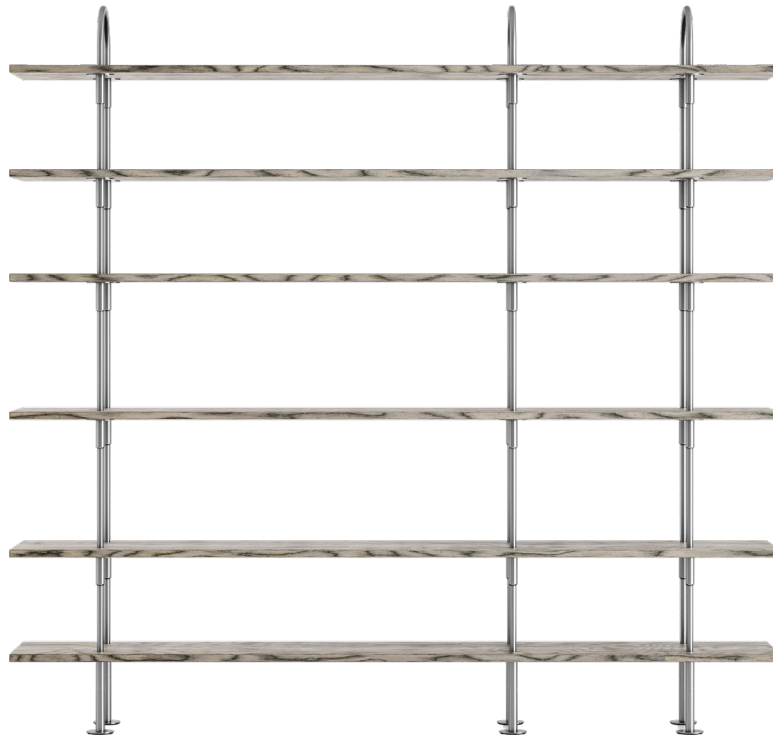

### ITEM NUMBER

Keen Shelving System, 3 Arches, 208, 6 shelves (Frame: Satin Stainless Steel, Shelves: Brown/Black Ash Veneer) - 10143818  
Keen Shelving System, 3 Arches, 208, 6 shelves (Frame: Black Brass, Shelves: Brown/Black Ash Veneer) - 10145122  
Keen Shelving System, 3 Arches, 208, 6 shelves (Frame: Satin Stainless Steel, Shelves: ALPI Sottsass Gray Veneer) - 10145772  
Keen Shelving System, 3 Arches, 208, 6 shelves (Frame: Black Brass, Shelves: ALPI Sottsass Gray Veneer) - 10145773

### DESCRIPTION

Created for GUBI by Linda Korndal's studio, Toko Among Friends, Keen is a modular shelving system defined by architectural structure, expressive personality, and quiet adaptability. Designed to evolve with its user, Keen expands both vertically and laterally through an intuitive rod-and-bracket system that keeps the composition visually complete at every stage. With seven core modules, frame options in black brass or satin-polished stainless steel, and shelves in FSC-certified black-brown stained ash, FSC-certified ALPI veneer, or cool-gray stained glass, the system brings sculptural rhythm, material depth, and emotional resonance to homes, hospitality settings, and workspaces alike.

## Materials & Finishes

### FRAME

Satin Stainless Steel, Black Brass



### SHELVES

Brown/Black Ash Veneer, Alpi Sottsass Gray

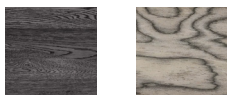

---

## Dimensions

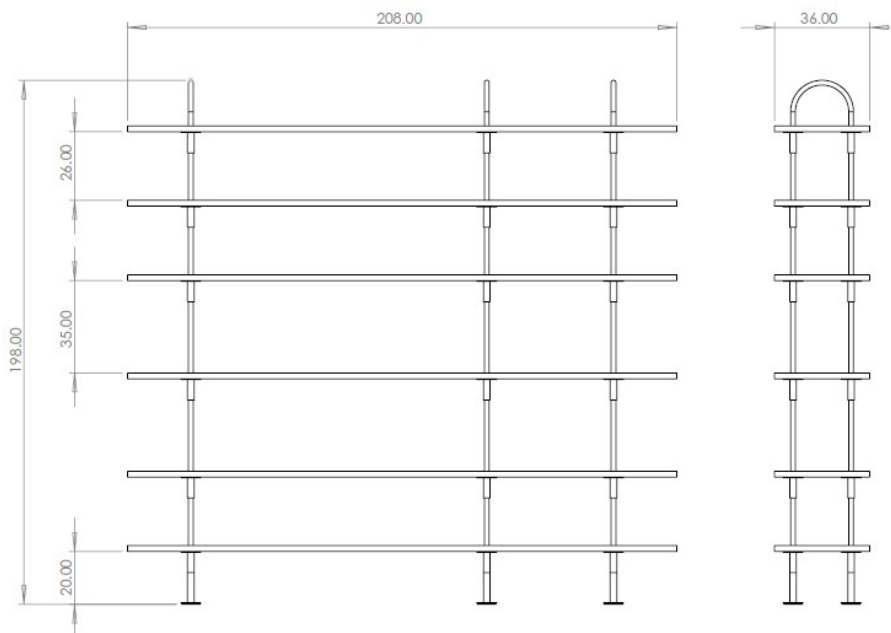

**WIDTH** 208 cm / 81.9 in

**DEPTH** 36 cm / 14.2 in

**HEIGHT** 198 cm / 78.0 in

---

## Weight

**TOTAL WEIGHT** 112.7 kg / 248.5 lbs

---

Number of parcels 7

**KEEN METAL COMPONENTS BOX M**

**PACKAGING LENGTH** 48.4 cm / 19.0 in

**PACKAGING WIDTH** 48.4 cm / 19.0 in

**PACKAGING HEIGHT** 51 cm / 20.0 in

**GROSS WEIGHT** 27.5 kg / 60.6 lbs

**KEEN SHELVING SYSTEM SHELF , 208X36CM**

**PACKAGING LENGTH** 216 cm / 85.0 in

**PACKAGING WIDTH** 44 cm / 17.3 in

**PACKAGING HEIGHT** 8.5 cm / 3.3 in

**GROSS WEIGHT** 14.2 kg / 31.3 lbs

---

Test & Certifications

FSC® C176589.

---

Mounting parts

**INCLUDED** Yes

---

