

Audo

COPENHAGEN



INTERCONNECT CANDLE HOLDER
Designed by *Colin King Studio*

PRODUCT SHEET



INTERCONNECT CANDLE HOLDER
Designed by *Colin King Studio*

A sphere, an angle and a line meet on the Interconnect Candle Holder, a bold and illuminating centrepiece of exaggerated proportions. Available in painted steel, and polished or bronzed brass, it goes beyond its intended use to function as a sculpture.



BLACK STEEL



POLISHED BRASS



BRONZED BRASS

TECHNICAL SPECIFICATIONS

PRODUCT TYPE
Candle holder

COLLI
2

DIMENSIONS
H: 41,5 cm / 16,3"
W: 70 cm / 27,6"
D: 13 cm / 5,1"

PRODUCTION PROCESS
The candle holder is made connecting rods, stamping, and cut components in either in solid brass or painted steel.

COLOURS
Black (RAL 9005)
Brass
Bronzed Brass

GLOSS
Gloss

MATERIALS
Brass or painted steel

WEIGHT
Steel: 2,04 kg / 4,5 lb
Brass: 2,28 kg / 5 lb

PACKAGING TYPE
Gift box

PACKAGING MEASUREMENTS
(H x W x D)
40 cm x 86 cm x 16,5 cm /
.7" x 33,9" x 6,5"

MATERIALS & MAINTENANCE
Please visit [www.colin-king.com](#) for materials, care and maintenance instructions.

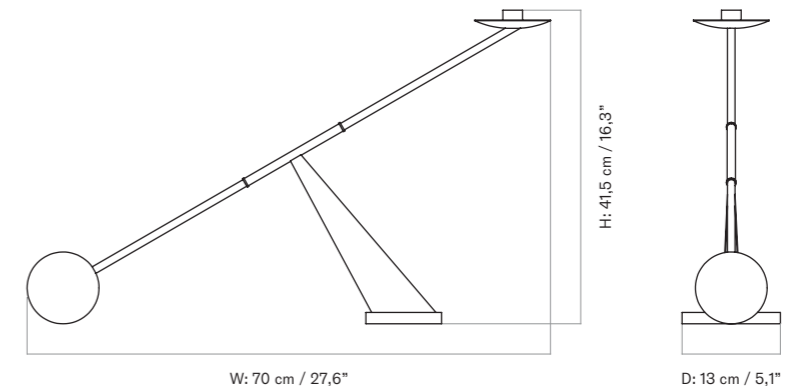



INTERCONNECT CANDLE HOLDER, SMALL
Designed by *Colin King Studio*

A sphere, an angle and a line meet on the Interconnect Candle Holder, a bold and illuminating centrepiece of exaggerated proportions. Available in painted steel, and polished or bronzed brass, it goes beyond its intended use to function as a sculpture.



BLACK STEEL



POLISHED STEEL



BRONZED BRASS

PRODUCT TYPE
Candle holder

COLLI
2

DIMENSIONS
H: 25,5 cm / 10"
W: 42,5 cm / 16,7"
D: 9 cm / 3,5"

PRODUCTION PROCESS
The candle holder is made connecting rods, stamping, and cut components in either in solid brass or painted steel.

TECHNICAL SPECIFICATIONS

COLOURS
Black (RAL 9005)
Polished steel
Bronzed brass

GLOSS
Gloss

MATERIALS
Brass or painted steel

WEIGHT
N / A

PACKAGING TYPE
Gift box

PACKAGING MEASUREMENTS
(H x W x D)
N / A

MATERIALS & MAINTENANCE
Please visit [audocopenhagen.com](#) for materials, care and maintenance instructions.