

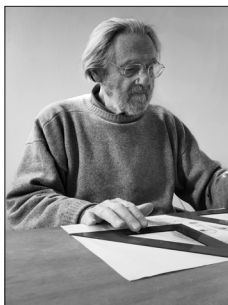

Scarpa 121

Design Afra & Tobia Scarpa

Year 1965



Afra & Tobia Scarpa

Afra Bianchin () and Tobia Scarpa (1935-) first met at the IUAV, University of Venice, where they graduated as architects in . This marked the beginning of a partnership, marriage, and a career with an impressive impact on Italian design in the 1970s and 1980s. The Scarpa's influenced the golden years of design and production 'Made in Italy' with their modernist aesthetic and constant focus on the technical and aesthetic possibilities of materials in their designs. Their work consists of architecture, everyday household items, art glass, and exclusive home interior design pieces.



The iconic 121 Scarpa dining chair is a straightforward dining chair with a design that can complement both classical and cutting-edge interiors.

The design is characterized by a firm and robust wooden frame that creates a striking contrast to the lightness of the seat and back. The seat and back are anatomically shaped in plywood, covered in fine European leather, and attached by bolts to crosspieces along the center for great comfort. Originally inspired by a sketch made by Tobia's father, Venetian architect and designer, Carlo Scarpa, the 121 came to life with a distinct touch from **Afra and Tobia Scarpa** in

The 121 Scarpa dining chair was designed alongside **the classic 925 Scarpa lounge chair** from **The two** chairs are a prime example of Afra and Tobia Scarpa's work and share the same double trestle structure with characteristic rounded joints. Both designs are now a part of the Karakter collection.

PRODUCT DATA

Design	Afra & Tobia Scarpa
Product type	Dining chair
Environment	Indoor
Materials	Frame in solid ash, HR/Cal.117 foam, upholstery in saddle leather, plastic glides

CMHR FOAM

CMHR foam available

DELIVERY - LAUNCHES SEPTEMBER 2025

Lead time	16 to 18 weeks
-----------	----------------

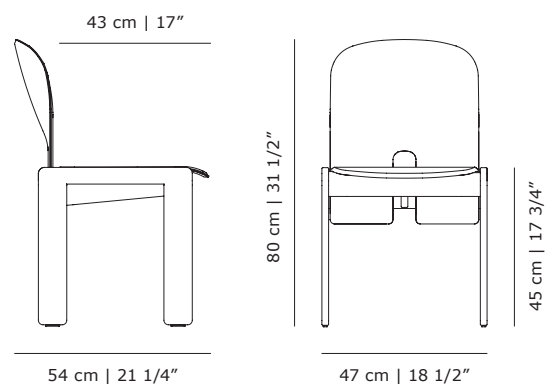



Scarpa 121

Frames and upholstery

Frames

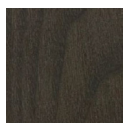

Solid ash
mocca stained



Solid ash
natural

Upholstery - Saddle leather

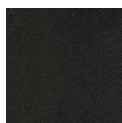

Nero C09

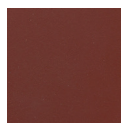

London C05



Naturale C16



Moka C11



Cognac C22



Founded on rebellious curiosity and a passion for the unique, Karakter is a bit out of the ordinary. Rooted in the proud Danish design tradition, but always maintaining an international outlook, Karakter presents a striking portfolio of furniture, lighting and objects from designers who have already written the history of design to those who are aspiring to write the future. All designers collaborating with Karakter are curated for their ideas and creativity and shared by all of them is an inspiring level of curiosity and an uncompromising take on their work. Boasting both the relevant and honest, the beautiful, the playful and the expressive, all designs have a clear, undeniable character. Ready to spark curiosity and start conversations.

Head Office

Karakter
Gammel Lundtoftevej 1C
2800 Kongens Lyngby
Denmark

T