

Black  
Ferrograin

Charcoal  
Satin

Light Grey  
Ferrograin

Light Grey  
High Gloss

Saddle Wood  
Ferrograin

White  
Ferrograin

White Satin

**Frame** Powdercoated Mild Steel  
**Upholstery** Fabric / Leather

**Dimensions (mm)**

420W x 540D x 760H

Seat high: 760 mm

**Dimensions (inches)**

16.5W x 21.2D x 29.9H

Seat high: 29.9 in

**COM** 1m / 1yd

**COL** 1.2m<sup>2</sup> / 13sq ft

Different textures, grains, colouration and densities are all natural characteristics of timbers. We find these variances an inherent and valuable part of the natural beauty of wood, no two pieces are the same making each OKHA design a unique, characterful piece and each product will be different from the next. Timber movement will also occur as this is a natural product.

STONE: Marble is a beautiful natural material with inherent imperfections in its structure, veining and coloration. As such, some slabs may be reinforced with meshing on the underside and may have colour matched resin fills in minor cracks and surface blemishes. Please note that this is standard practice.

METAL: All metals will go through a process of natural aging and oxidization due to environmental conditions. The result of this aging process will bring about colour change, to slow and reduce this natural process, appropriate cleaning and maintenance products can be used.

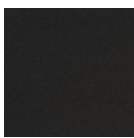
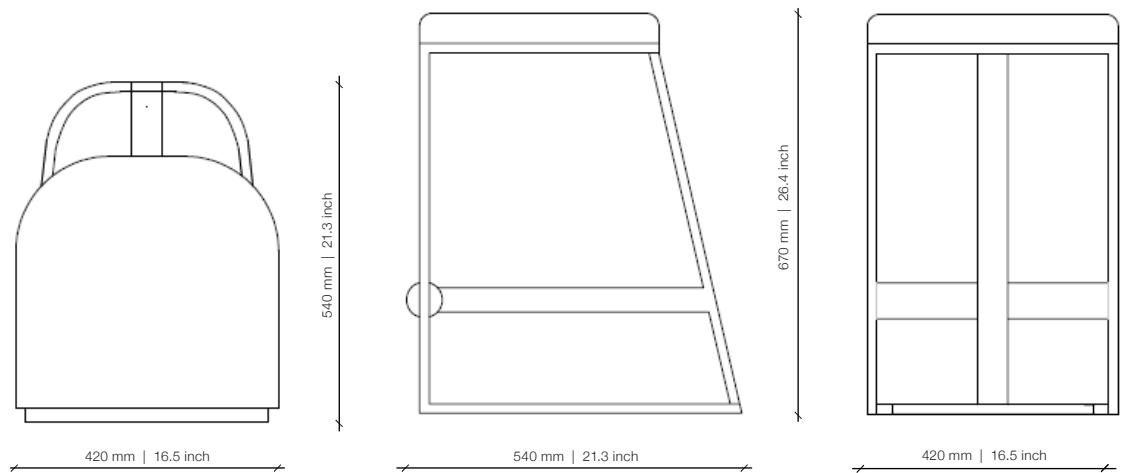

Black  
Ferrograin

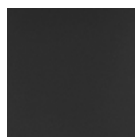

Charcoal  
Satin



Light Grey  
Ferrograin



Light Grey  
High Gloss



Saddle Wood  
Ferrograin

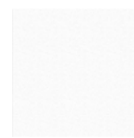

White  
Ferrograin

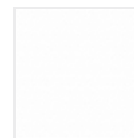

White Satin

**Frame** Powdercoated Mild Steel  
**Upholstery** Fabric / Leather

**Dimensions (mm)**

420W x 540D x 670H

Seat high: 670 mm

**Dimensions (inches)**

16.5W x 21.3D x 26.4H

Seat high: 26.4 in

**COM** 1m / 1yd

**COL** 1.2m<sup>2</sup> / 13sq ft

Different textures, grains, colouration and densities are all natural characteristics of timbers. We find these variances an inherent and valuable part of the natural beauty of wood, no two pieces are the same making each OKHA design a unique, characterful piece and each product will be different from the next. Timber movement will also occur as this is a natural product.

STONE: Marble is a beautiful natural material with inherent imperfections in its structure, veining and coloration. As such, some slabs may be reinforced with meshing on the underside and may have colour matched resin fills in minor cracks and surface blemishes. Please note that this is standard practice.

METAL: All metals will go through a process of natural aging and oxidization due to environmental conditions. The result of this aging process will bring about colour change, to slow and reduce this natural process, appropriate cleaning and maintenance products can be used.