

# SkLO

## Float 1.0

### PENDANT

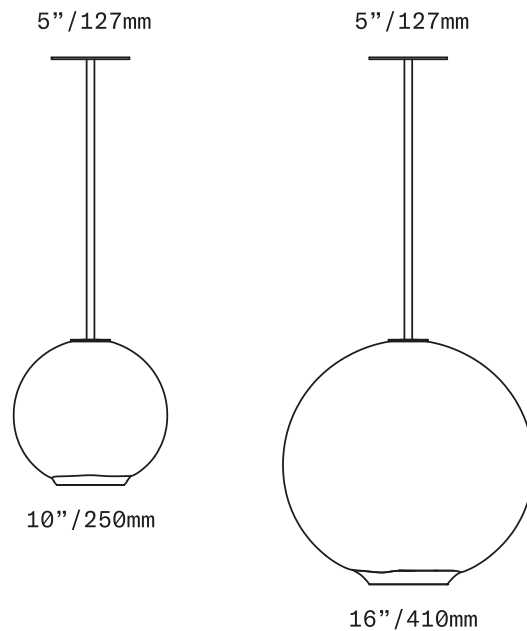

Spheres of lit handblown glass suspended on brass tube stems, the Float 1.0 Pendants are both simple and elegant. The openings at the bottom of the glass feature an organic, layered detail where we dip the spheres twice into the molten glass during production. The lip of the opening is then cut and polished smooth. These details express their handmade nature without sacrificing their minimal feel. Available in two sizes.

UL listed suitable for dry and damp locations (US & Canada)

Socket 120V E26 60W Max

LED bulb included

Requires recessed electrical box for installation

Standard canopy does NOT accommodate sloped ceilings or swagging of this light. Other canopy options are available at an additional cost. Visit the Accessories page on our website to see available canopy options and review compatibility

This fixture is compatible with one or more of SkLO customizable multi-pendant canopy systems. Visit the Accessories page on our website to see available systems and review compatibility

Specify overall drop length – Rigid brass tube stems are not field adjustable

Minimum overall drop length: 22"/560mm

Lengths over 53"/1350mm available at additional cost

Fixture weights (approximate): 8lbs/3.5kg (LT253)  
**lbs/7kg (LT254)**

All glass dimensions are approximate – handblown glass dimensions vary by nature and intent

Made in the Czech Republic

LT253 [---][--]

LT254 [---][--]

Glass colors

10"/250mm glass

16"/410mm glass

- Amber [AMB]
- Clear [CLR]
- Smoke [SMK]
- Smokey Brown [SMB]
- White [WHT]

Metal finishes

- Dark Oxidized [DX]
- Brushed Brass [BB]
- Brushed Nickel [BN]
- Polished Nickel [PN]

