

FEATURES

- Newest design with 5 Manual Switches, easy programming.
- 15M/49ft Patent Protected Module, Effectively anti-interference.
- 12VDC Input, 0-10V Dimming, with Daylight Harvesting and Photocell Function.
- Elegant and classic round design, with rotators for easy programming.
- Rotator & Remote control.

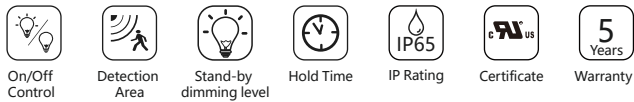

TECHNICAL DATA

Microwave Information	
Frequency	5.8GHz±75MHz
Microwave Power	<0.3mW
Installation Height	≤15m/49.21 Max.
Detection Distance	Radius: 4-8m/13.12-26.24ft
Detection Angle	30-150° (Without Glass Cover)
Working Temp	-40°C~+70°C

Electrical Specifications	
Input Range	12-24VDC
Stand-by Power	<30mA
Warm-up Period	10s
Output control	NO/OFF, 0-10V DIM

Match Emergency Drivers

*Work compatibly with EM driver, please make sure it follows below conditions:

1. Switching capacity <1mA
2. LED driver's OFF voltage at 1mA is 0.25-0.3V
3. Single fixture connected.

Factory default settings

1. Detection area 100%
2. Hold time 5S
3. Daylight threshold disable
4. Standby dimming level 10%
5. standby period 0S

Sensor Parameter	
Control Device	Remote Control #SZ-MS-RC1(purchase separately) Manual Switches
Detection Area	Remote Control : 25% / 50% / 75% / 100% Rotating switch: 25% / 50% / 75% / 100%
Holdtime	Remote Control: 5s / 30s / 1min / 3min / 5min / 10min / 20min / 30min Rotating switch: 5s/1min/ 5min/10min
Daylight Threshold	Remote Control: 2lux / 10lux / 30lux / 50lux / 80lux / 120lux / 200Lux / 250Lux / 300lux / 350Lux / 400Lux / Disable Rotating switch: 50Lux / 200Lux / 400Lux / Disable
Standby Period	Remote Control: 0s / 10s / 30s / 1min / 5min / 10min / 30min / 60min / +∞ Rotating switch: 0s / 10min / 30min / +∞
Standby Dimming Level	Remote Control: 10% / 20% / 30% / 50% Rotating switch: 10% / 20% / 30% / 50%
Automatically Dimming (Daylight Harvesting)	1. Stay in SENSOR MODE 2. STANDBY PERIOD as 0S 3. DAYLIGHT as any of 50Lux / 80Lux / 120Lux / 200Lux / 250Lux / 300Lux / 350Lux / 400Lux 4. Press DAYLIGHT HARVESTING button to ON
Automatically ON/OFF (Photocell)	1. STANDBY DIM LEVEL as any of 10% 20% 30% 2. STANDBY PERIOD as infinite 3. DAYLIGHT as any of 30Lux / 50Lux / 80Lux / 120Lux / 200Lux / 250Lux / 300Lux / 350Lux / 400Lux

DIMENSIONS

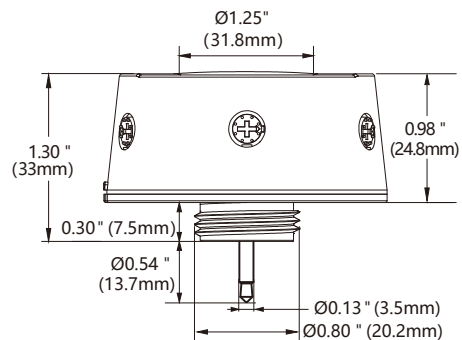
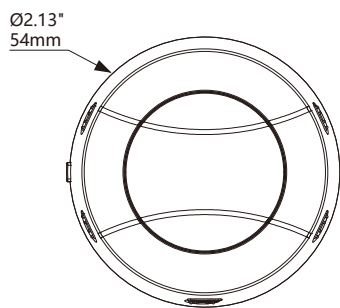

WIRING DIAGRAM

- +12V 12VDC input
- GND 0/1-10V DIM
- DIM+ 0/1-10V DIM+

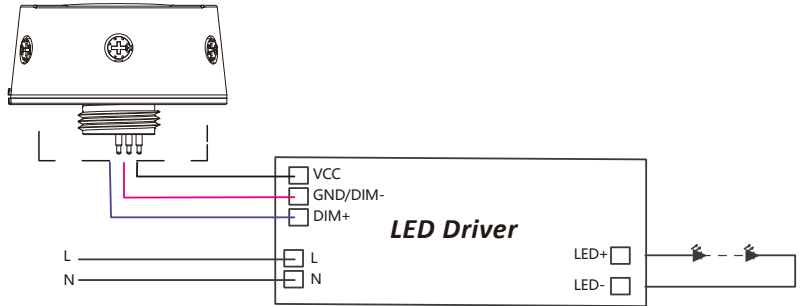

PROGRAMMING

- ① Detection Area
25% / 50% / 75% / 100%
- ② Holdtime
5s/1min/ 5min/10min
- ③ Daylight Threshold
50Lux / 200Lux / 400Lux / Disable
- ④ Standby Period
0s/ 10min/ 30min/ +∞
- ⑤ Standby Dimming Level
10%/ 20%/ 30%/ 50%

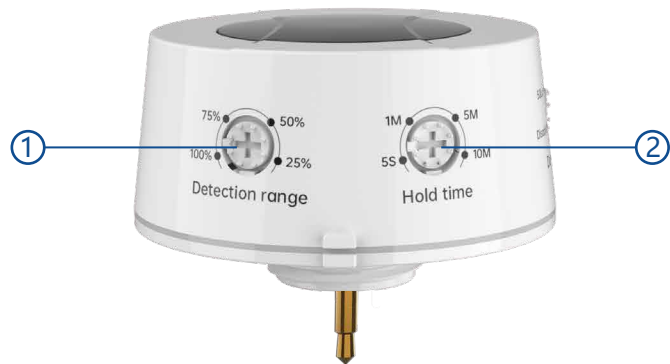

RECEPTACLE OPTIONS

Type	Name	Wire color	Length
3 pogo-pin connection	HD07VRA	Black/white, Pink,Purple	12.99"
	HD07VRA-3	Yellow, Pink,Purple	7.87"
	HD07VRB	Black/white, Pink,Purple	12.99"

HD07VRA

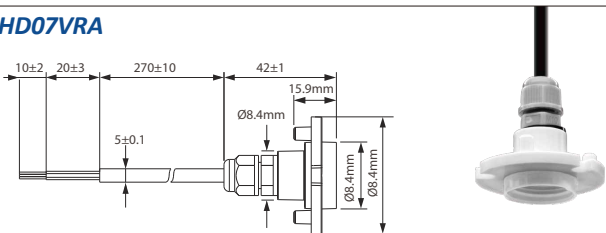

Type	Name	Wire color	Length
Audio Jack connection	HD07VRA 2	Black/white, Pink,Purple	12.99"
	HD07VRA-3-1	Yellow, Pink,Purple	11.81"
3 pogo-pin connection	HD07VRC	Yellow, Pink,Purple	11.81"

HD07VRA 2

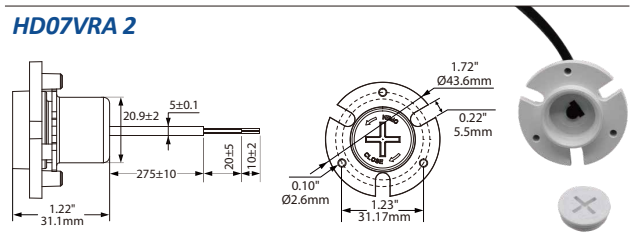

HD07VRA-3

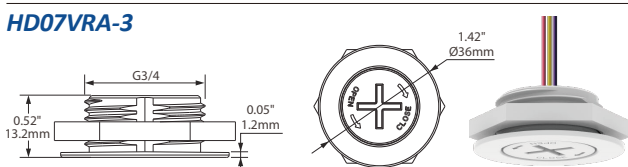

HD07VRA-3-1

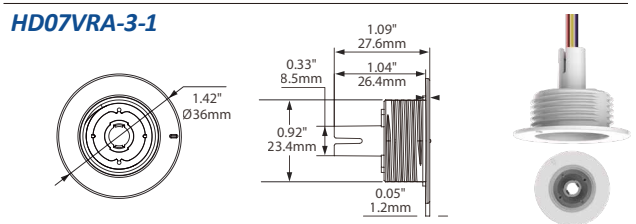

HD07VRB

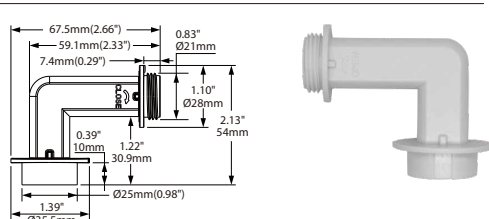

HD07VRC

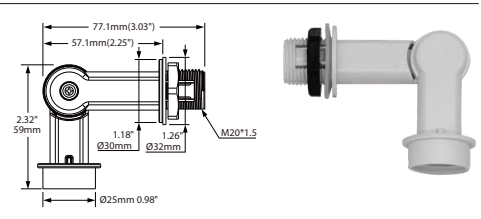

DETECTION COVERAGE

Highest mounting height is 15m

This figure indicates the maximum distance at the highest mounting height with 100% sensitivity.

- Well Detected Area
- Possibly Detected Area

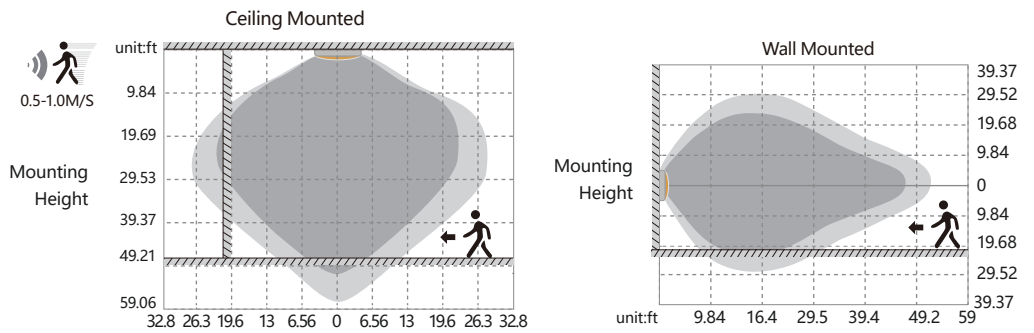

PERFORMANCE

1. Daylight Harvesting

Please follow below setting steps to perform this function:

1. Stay in SENSOR MODE
2. STANDBY PERIOD as 0S
3. DAYLIGHT as any of 50Lux / 80Lux / 120Lux / 200Lux / 250Lux / 300Lux / 350Lux / 400Lux
4. Press DAYLIGHT HARVESTING button to ON

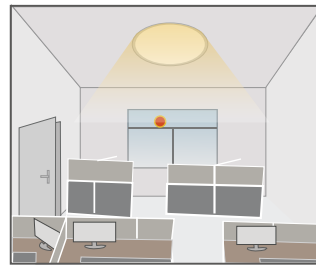
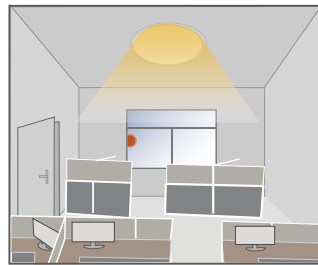
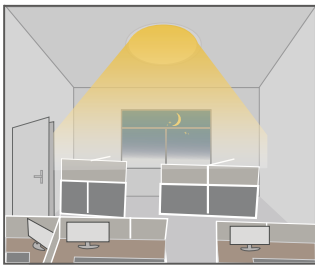
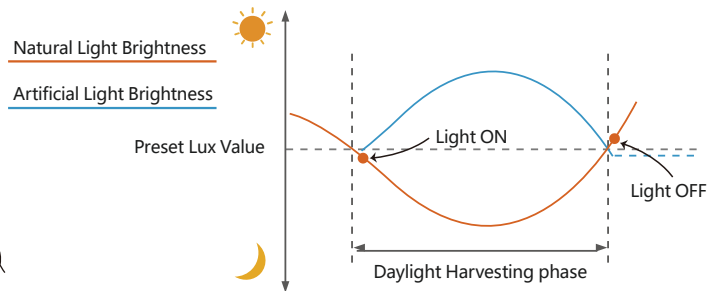

When ambient brightness is lower than preset lux level, sensor will turn on light automatically and keep dimming according to the change of the ambient brightness; when outside is getting darker, the inside will be brighter, and brighter darker.

Light OFF when ambient brightness becomes higher than the preset lux level.

2. Dusk/Dawn function

This series is able to differentiate artificial light brightness from natural light after installed inside the fixture, and automatically turn off light when ambient brightness exceeds preset lux level.

Please follow below setting steps to perform this function:

1. STANDBY DIM LEVEL as any of 10% 20% 30%
2. STANDBY PERIOD as infinite
3. DAYLIGHT as any of 30Lux / 50Lux / 80Lux / 120Lux / 200Lux / 250Lux / 300Lux / 350Lux / 400Lux

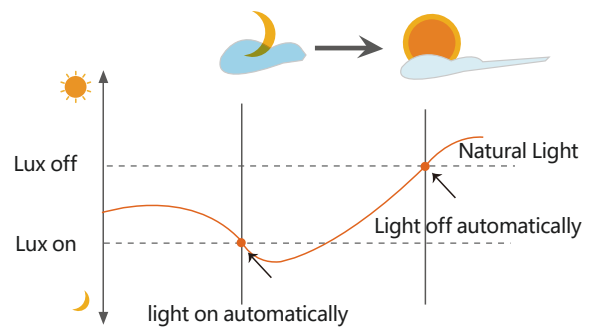

3. With Dusk/Dawn function

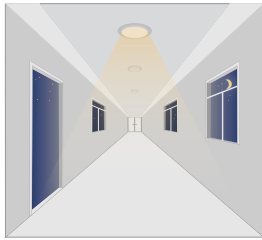

With insufficient ambient brightness, sensor turns on light and keeps it at standby dimming level even if there is no motion or presence.

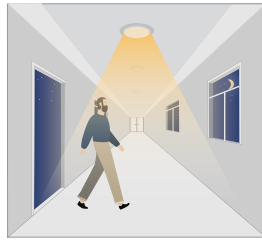

When sensor detects motion or presence it will bring the light level up to 100%.

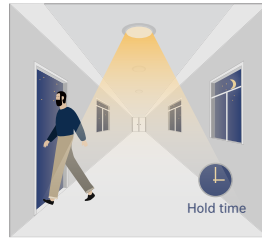

After motion is no longer detected, fixture remains at 100% for hold time.

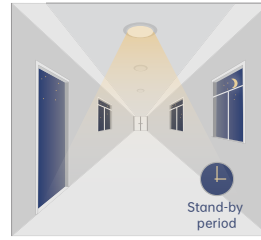

After pre-set hold time period it will dim light to standby dimming level again and always keep it.

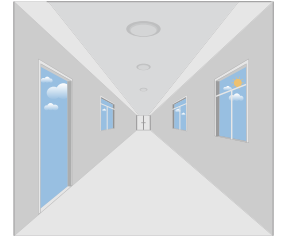

With sufficient ambient brightness, sensor will turn OFF light automatically.

4. Without daylight disabled

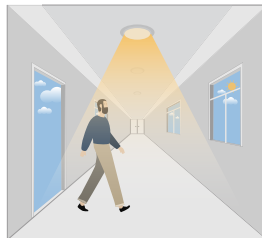

Sensor turns ON light when motion is detected.

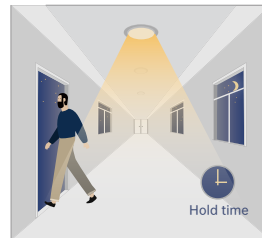

Sensor keeps for a hold time period after motion leaves

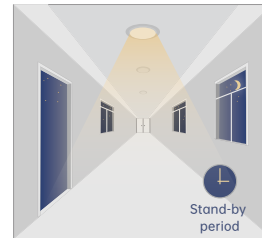

Sensor dims light to standby dimming level after hold time if there is still no motion

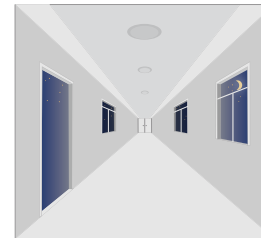

Sensor turns OFF light after standby period

5. With Daylight Threshold

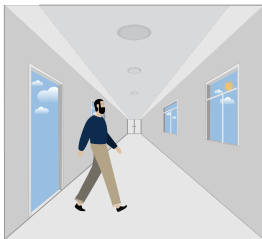

With sufficient daylight, the sensor keeps light OFF even motion gets detected

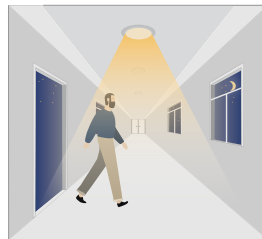

With insufficient daylight, the sensor turns light ON when motion gets detected

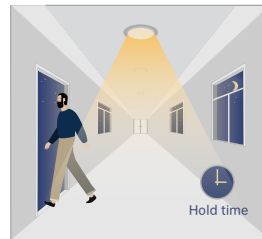

After there's no motion detected, the sensor keeps light ON 100% for holdtime.

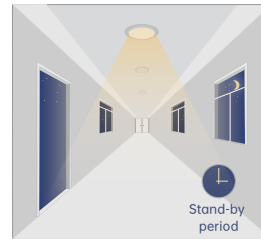

After holdtime, sensor dims light to standby dimming level for standby period. if the standby period has been set as 0s, sensor turns light OFF automatically after holdtime.

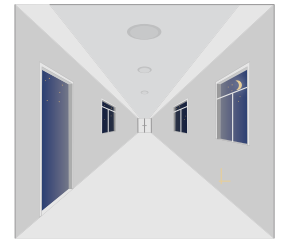

The sensor turns OFF light automatically after the standby period when there's no motion detected.

FACTORY SETTING

1. Detection Area - 100%
2. Holdtime - 5S
3. Daylight Threshold - disable
4. Standby Period - 0S
5. Standby Dimming Level - 10%



Attention

1. The sensor should be installed by qualified electrician and ensure power is OFF before installation.
2. Please read the instruction carefully before using the product and keep it well for other users to read any time.
3. We reserve the right to modify any incorrect text, image and technical parameters.
4. Any unauthorized modification is forbidden. Otherwise all guarantees will be immediately invalid.
5. Product could be optimized without prior notice.

APPLICATION NOTES

1. Suitable for indoor application, half/completely outdoor environment conditions might be captured as moving signals to trigger the sensor.
2. Suitable for ceiling mount installation, adjust sensitivity properly if it's installed on side-wall because it gets more sensitive.
3. Adjust sensitivity properly when the sensor is applied in small/narrow/metal-built/with metal spaces.
4. Microwave sensor can't be placed under/inside metal shell; Microwave module must directly face the detection area with edge lower than light fixture.
5. Keep the sensor away from vibration equipments, air-conditioning outlets, smoke extractors alike conditions to avoid unwanted trigger.
6. Keep the sensor module away from AC input and DC output to avoid high/low frequency signal interference.
7. At least 2m/6.5ft distance between microwave sensors; 1.5m/4.9ft between the sensor and other wireless devices such as routers to avoid possible radio interference.
8. Daylight testing delivered in bright day without shadow or specially designed lampshade or lens.
9. Dimming performance differs when connected to different drivers; If the driver can't completely turn OFF, sensor can't either.
10. Input power voltage must be stable with float less than 10%.
11. The first time powered ON sensor, light will be ON 100% for about 10S then dims to standby level or OFF.
12. Distance detection is delivered by testing person about 165cm in open area as reference, the result differs by size and speed of moving objects, mounting height and real-life situation.