

# Emergency driver

## FEATURES

- UL listed for field or factor installation,CEC title 20 compliant
- Compliance with American NFPA 101 life Safety Code.
- Easy installation,no need to open up a luminaire to connect this device to the driver,connect with the led lamp directly.
- With built-in junction box.
- 2 -in- 1 LED test switch and indicator light included
- Manual testing via remote control (optional)
- Monthly/annual self-testing
- With multi-protection function :
  - Batter overcharge protection
  - Batter over-discharge protection
  - Output overload protection
  - Shor-circuit protection
  - Open load protection
- 5 years limited warranty



## ELECTRICAL SPECIFICATIONS

- Input voltage: 100-347V AC,50/60Hz
- Input current: 0.15A max
- Input power: 12W Max
- Power factor: 0.6@100V AC, 0.5@347V AC
- Output voltage: 120-200Vdc 250V MAX
- Battery: Li-ion
- Recharge duration: 24Hrs
- Emergency duration: 90mins
- Ambient temp: 0-50°C(32°F-122°F)



## MODEL SELECTION TABLE

Models	Emergency Wattage	Recharge Duration	Battery Capacity	Compatible LED Fixture
SZ-EM30WR-HB (02)	30W	24Hrs	14.4V/5200mAh	30-240W LED lamp with 0-10V dimming or LED lamp less than 30W without 0-10V dimming
SZ-EM40WR-HB (02)	40W	24Hrs	14.4V/6600mAh	40-350W LED lamp with 0-10V dimming or LED lamp less than 40W without 0-10V dimming
SZ-EM60WR-HB (02)	60W	24Hrs	14.4V/9600mAh	60-500W LED lamp with 0-10V dimming or LED lamp less than 60W without 0-10V dimming

## NORMAL MODE

Fixtures will operate normally when power is available. When an outage occurs, the fixture will switch to emergency mode, delivering power to the fixture for up to 90 minutes.

## EMERGENCY MODE

1. The emergency battery backup enters the emergency mode immediately after the mains power failure.
2. Stop the emergency and return to the charging state after the mains power call.

# Emergency driver

## SELF-DIAGNOSTIC

### MONTHLY SELF-TEST

It will automatically perform a monthly self-test every 30 days with a duration of 30S to check whether the emergency function is normal, and automatically restore to normal charging after 30S discharged.

### ANNUAL SELF-TEST

An annual self-test will be done every year (12 months) with a duration of 90mins to check whether the capacity of the battery pack is normal, and automatically restore to normal charging after fully discharged. (the condition of annual test is that the battery pack is fully charged).

If the annual inspection is interrupted, it will be retested after recovery and when the test conditions are met. (Possibility of interruption: such as sudden power failure, sudden manual test).

## TEST BUTTON & LED INDICATOR

Operations	Test button operations	Remote control operations	Indicator status	Working status
Normal mode	Press and hold the test button	Press button A	OFF	Emergency mode
	/	Press button B	OFF	Monthly testing
	/	Press button C	OFF	Annual testing
	/	/	ON	Battery is charging or fully charged
Emergency mode	Press the test button 5S	/	OFF	Turn off the battery pack
Malfunction mode	/	/	Flashing	1.The battery pack is disconnected or it is broken. 2.The load is disconnected. 3.Short circuit or open circuit. 4.The wires are not connected properly.

## ACCESSORIES



2pcs M10 Hooks



1pc Safety Rope



20pcs Wire Nuts



5pcs Waterproof Connectors

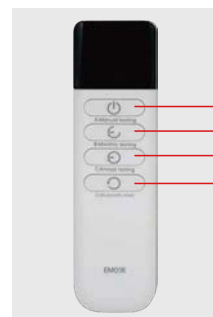

1pc Remote Control  
\*Optional

- A: Manual testing
- B: Monthly testing
- C: Annual testing
- D: Bluetooth reset

# Emergency driver

## BUILT-IN JUNCTION BOX

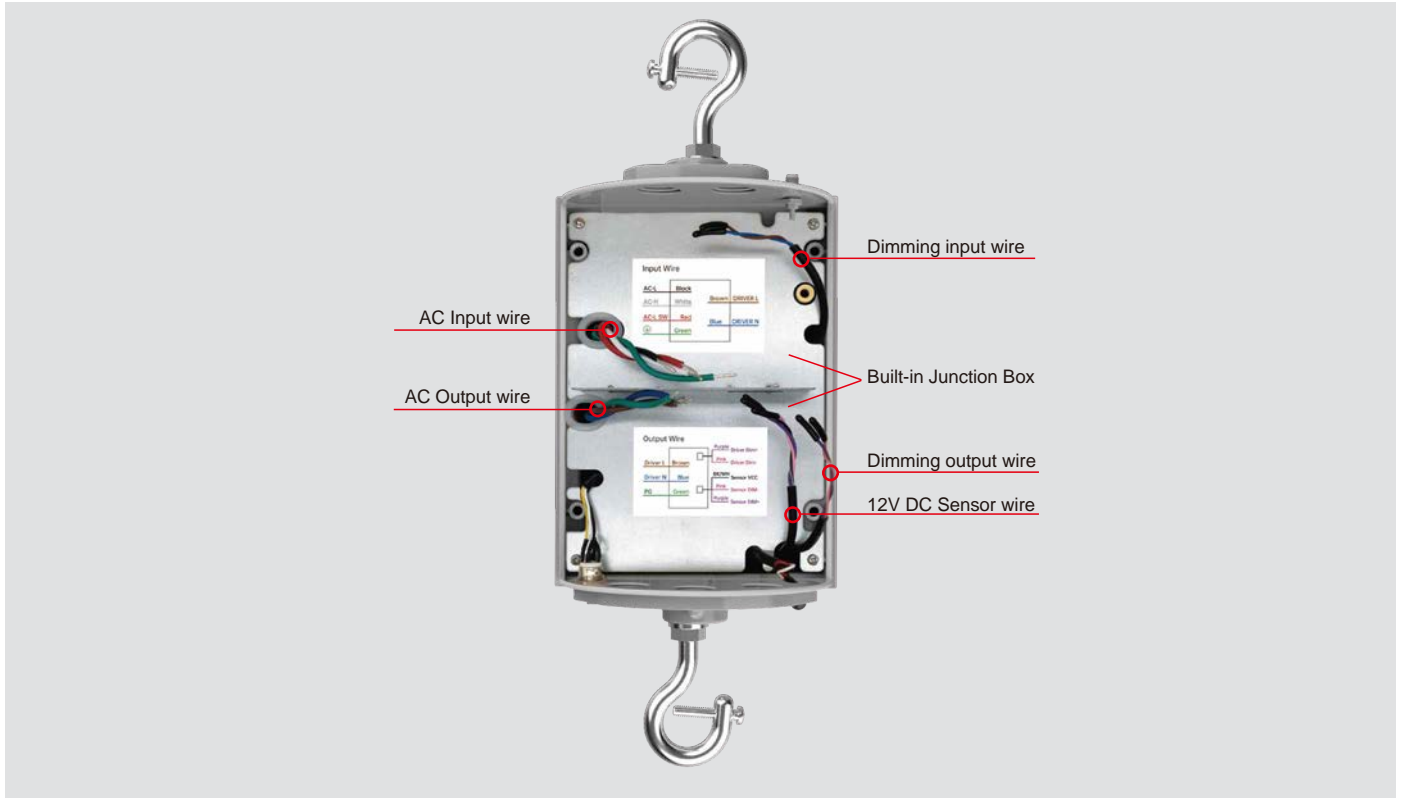

## HSE UFO EMERGENCY COMPATIBLE TO WORK WITH THE HSE SENSOR

HSE EM WORKS WITH HAISEN SENSOR	OTHER BRAND EM WORKS WITH THE SENSOR				
	<p>VS</p>				
<p>1. The sensor gets the power from the fixture and is mounted on the fixture; 2. When there's power outage, the EM will bypass the sensor and have 100% on for more than 90 min</p>	<p>Case 1</p>	<p>1. Sensor has to be connected with the 12V AUX from the emergency led driver. 2. The installation way is more complex.</p>	<p>Case 2</p>	<p>✘</p>	<p>When in emergency mode, the sensor still works, it will turn off the light when no motion is detected, the emergency led driver will switch to malfunction mode (No-load protection)</p>

# Emergency driver

## MOUNTING CONFIGURATION

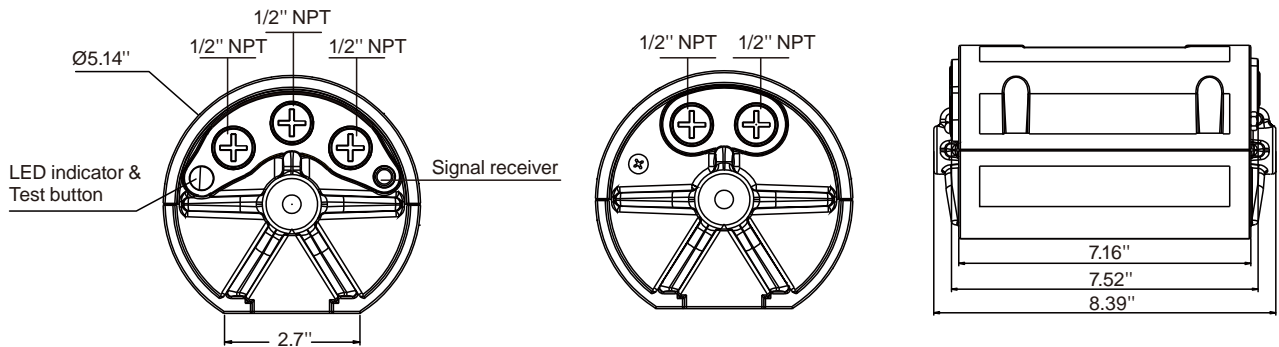

## INSTALLATION INSTRUCTION

1. Remove the plastic caps and install the hooks, waterproof connectors & bluetooth antenna (Only for bluetooth version) on the emergency driver.
2. Turn off the mains power and select a suitable location on the ceiling for hangable device.
3. Hang the emergency driver on the mounting hook and fix it with the screws.
4. Lock the safety rope on the emergency driver and Fix it on the ceiling.
5. Install the luminaire onto the hook of the emergency driver, then lock the safety screw.
6. Open the front cover of the emergency driver, then route the AC power cables, luminaire power and dimming cables through the waterproof connector into the the J-box, and wire according to the diagram.
7. Fasten all the screws of the front cover for the emergency driver, and installation is complete.

\*Remark: 1.The maximum weight of lighting fixture should less than 20kg(44.09lbs).

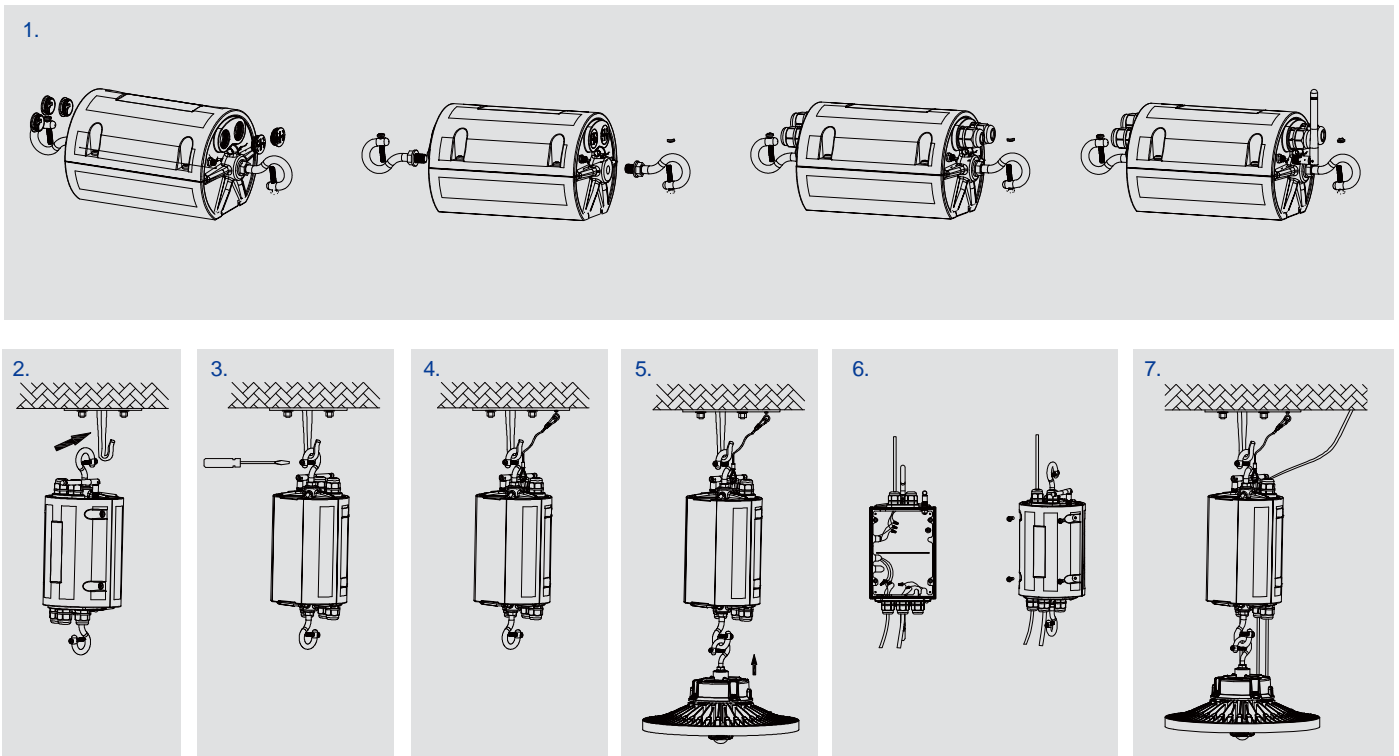

# Emergency driver

## WIRING DIAGRAM (Note: The LED fixture must be integrated with 0/1-10V dimmable LED driver)

### 1. With Dimmer ▲ Driver Power ≥ Emergency Power

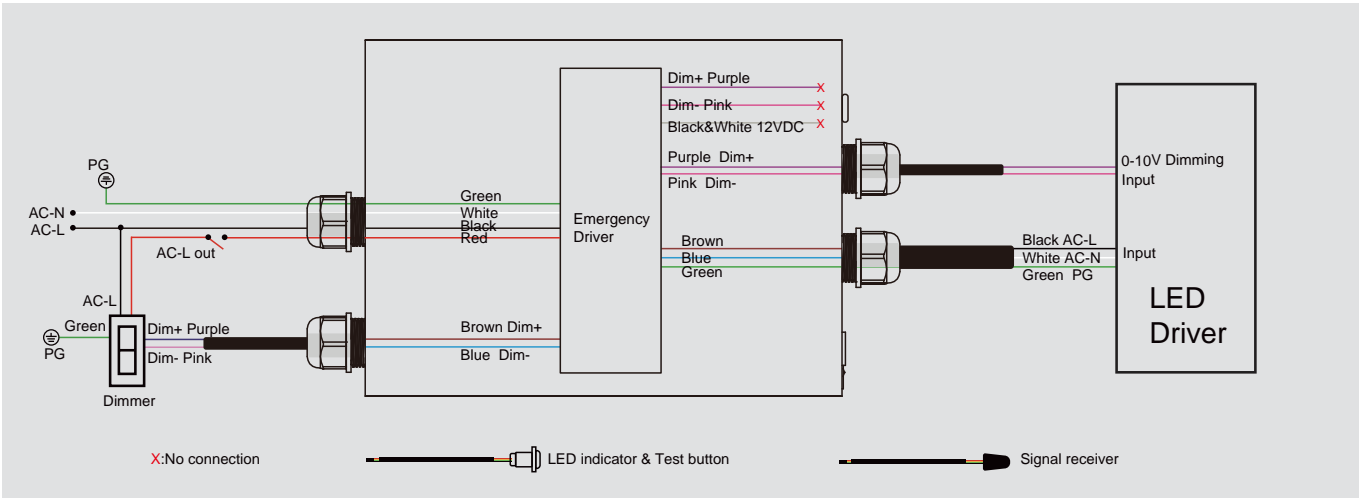

### 2. With Wall Switch ▲ Driver Power ≥ Emergency Power

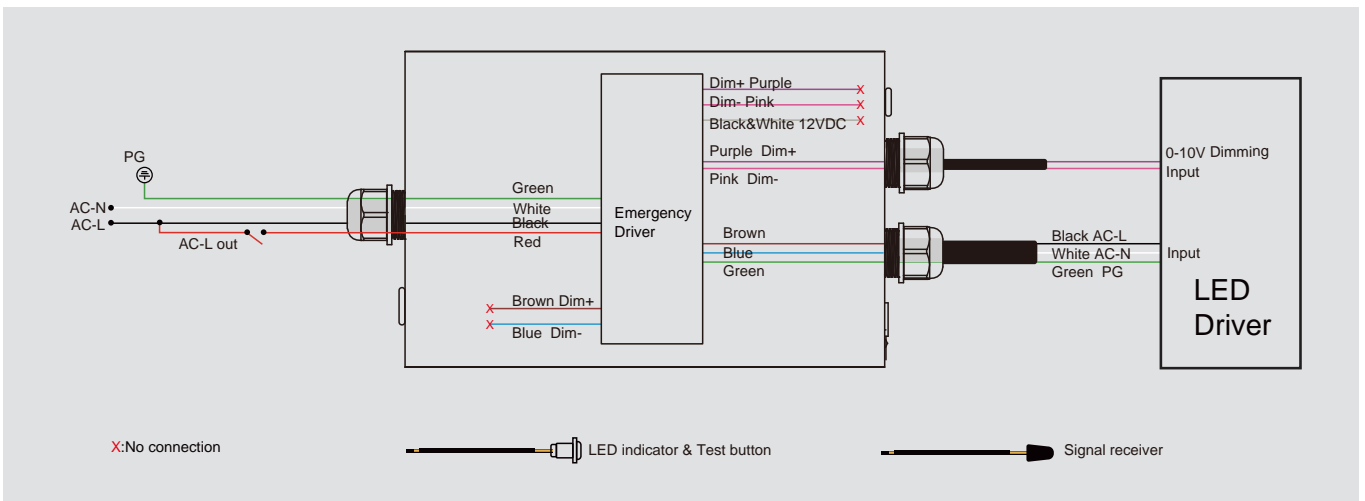

### 3. With 12VDC Sensor ▲ Driver Power ≥ Emergency Power

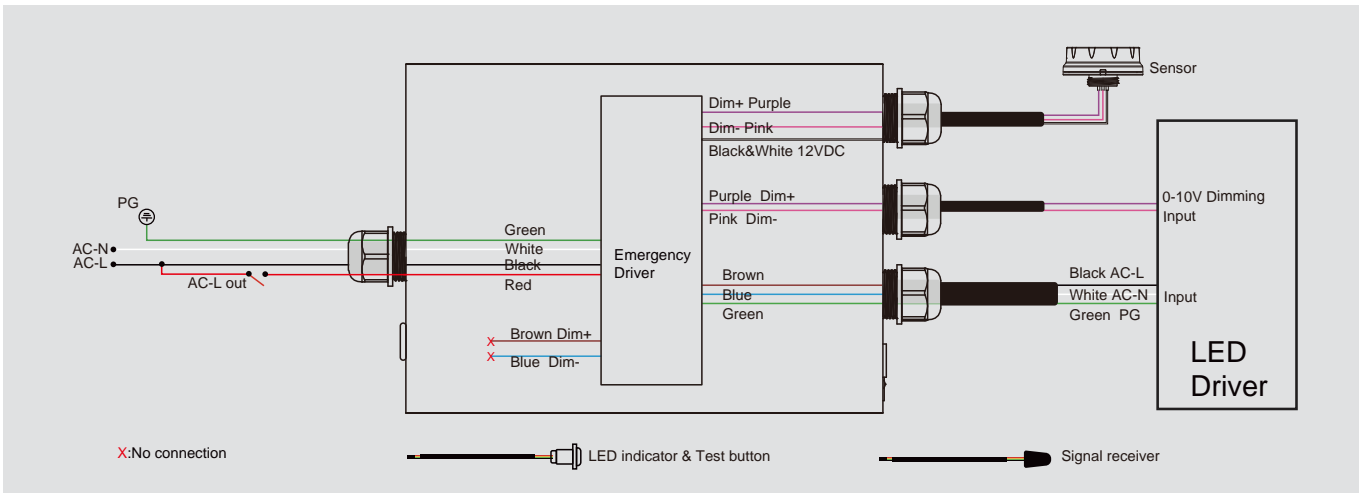

# Emergency driver

## 4. With AC Sensor ⚠ Driver Power ≥ Emergency Power

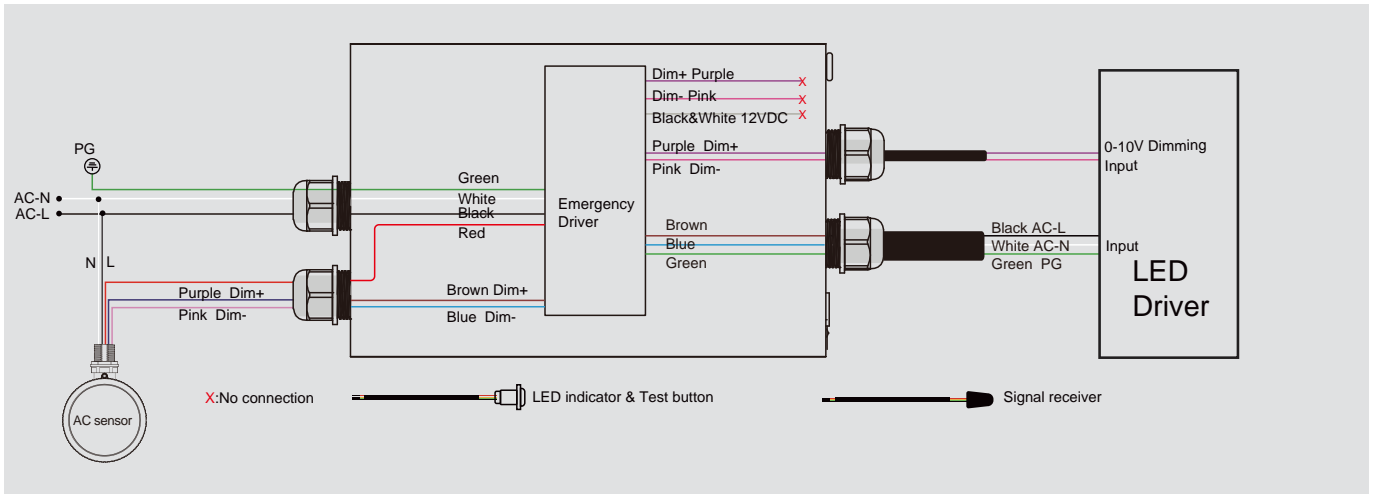

## 5. With Wall Switch ⚠ Driver Power < Emergency Power

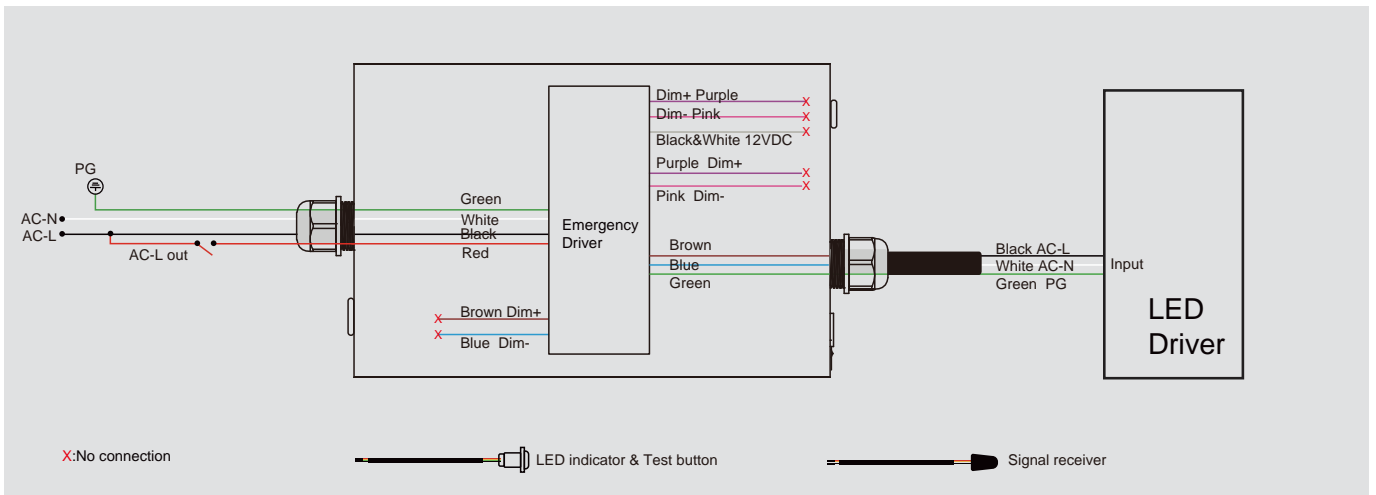

## IMPORTANT SAFEGUARDS

When using electrical equipment, basic safety precautions should always be followed, including the following:

**CAUTION**

**READ AND FOLLOW ALL SAFETY INSTRUCTIONS**

1. CAUTION – To prevent electrical shock, do not mate unit connector until installation is complete and AC power is supplied to the unit.
2. CAUTION – This fixture provides more than one power supply output source. To reduce the risk of electrical shock, disconnect both normal and emergency sources by turning off the AC branch circuit and by disconnecting the unit connector.
3. CAUTION – This is a sealed unit. Components are not replaceable. Replace the entire unit when necessary.
4. CAUTION – Installation and servicing should be performed by qualified personnel only. De-energize before opening.
5. This series is for use with grounded LED luminaires listed to UL standards. Not for use in heated air outlets or hazardous locations.

## Emergency driver

5. This series is for use with grounded LED luminaires listed to UL standards. Not for use in heated air outlets or hazardous locations.
6. This series requires an unswitched AC power source of 100 to 347 volts, 50/60 Hz.
7. This series and AC driver must be on the same branch circuit.
8. Do not mount near gas or electric heaters.
9. This series should be mounted in locations and at heights where it will not readily be subjected to tampering by unauthorized personnel.
10. This series will supply 120-200 VDC output at the individual rated specification for 90 minutes.
11. Suitable for use in damp locations and plenum spaces.
12. Flexible metal conduit is optional, depends on installation environment.
13. For use in 0° C minimum, 50° C maximum ambient temperatures.
14. Do not use this equipment for other than intended use.
15. Install in accordance with the National Electrical Code and local regulations.
16. Lighting fixture manufacturers, electricians, and end-users need to ensure product system compatibility before final installation.