

Orthobiologics

Next Generation in Biologics Technology

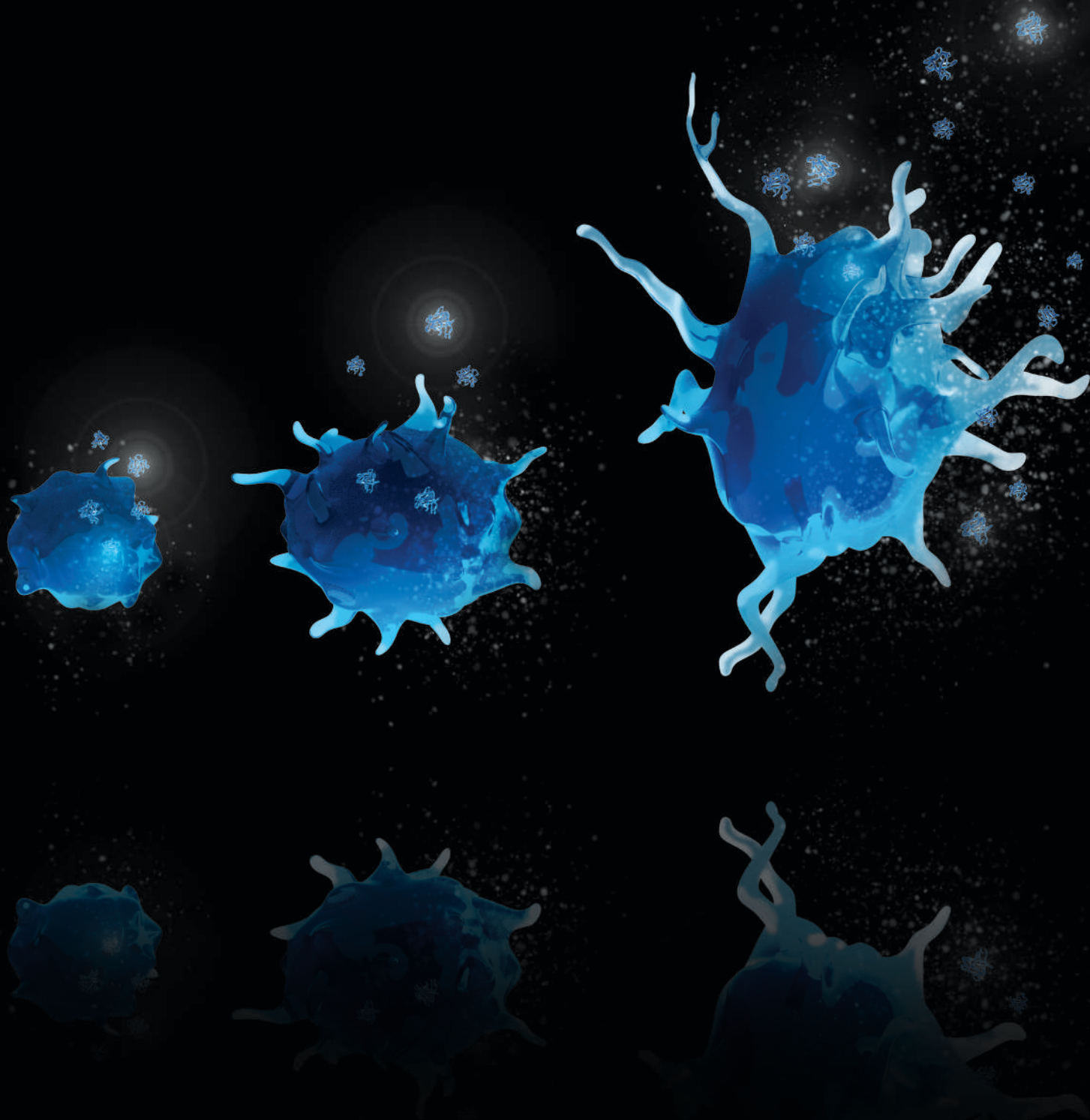

Helping Surgeons Treat Their Patients Better®

Since its inception, Arthrex has been committed to one mission: Helping Surgeons Treat Their Patients Better. We are strategically focused on constant product innovation through scientific research, surgeon collaboration, and medical education to make less invasive surgical procedures simple, safer, and more reproducible. Each year, we develop more than 1,000 new innovative products and procedures to advance minimally invasive orthopedics worldwide.

Arthrex has always remained a privately held company, which allows for the rapid evaluation of new technologies and ideas and the freedom to develop products and techniques that truly make a difference. Our experienced team of dedicated professionals represents a shared passion and commitment to delivering uncompromising quality to the health care providers who use our products and the millions of patients whose lives we impact.

The medical significance of our contributions serves as our primary benchmark of success and will continue into the future as the legacy of Arthrex.

05	Cellular and Molecular Biologics
15	Bone Repair
39	Cartilage and Meniscus
57	Soft Tissue
73	Surgical Incision Management
78	Notes

Cellular and Molecular Biologics

- 06 Arthrex ACP® Double-Syringe System
- 07 ACP Max™ PRP System
- 08 Angel® cPRP System
- 09 Bone Marrow Aspiration
- 10 Vortex™ Threaded Recovery Needle With Angel® cPRP System
- 11 Viscous Delivery Systems
- 12 Thrombinator™ System for Use With Arthrex PRP Systems
- 13 AutoPose™ System for Adipose Tissue Harvesting

Arthrex ACP® Double-Syringe System

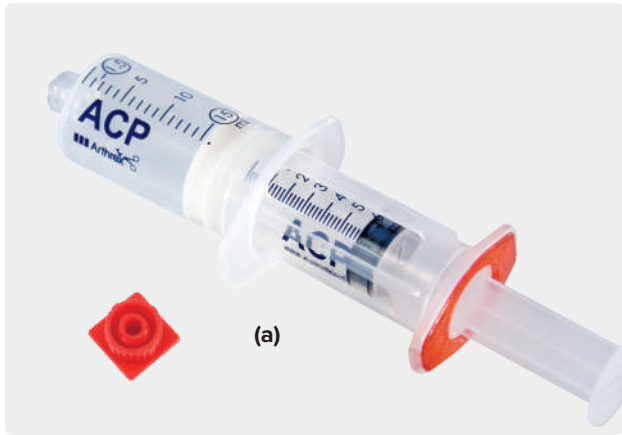

There has been increased interest in autologous blood products for use in a number of orthopedic therapies. The main effects of platelet-rich plasma (PRP) are thought to be caused by growth factors released from the platelets, which may play a beneficial role within these therapies.

- › The Arthrex ACP (autologous conditioned plasma) system allows for rapid and efficient concentration of platelets and growth factors from autologous blood for use at the treatment site
- › The unique double-syringe design allows for convenient and safe handling, as the whole preparation process takes place in a closed system
- › The Arthrex ACP system is easy to use and has a quick procedure time
- › White blood cells, specifically neutrophils, are NOT concentrated within the ACP system. These cells, which release degradative proteins and reactive oxygen species, can be detrimental to the healing process.^{1,2}

ACP double syringe w/ cap (a)	ABS-10010S
Series I ACP blood draw kit (c)	ABS-10011
Series I ACP kit w/ ACD-A	ABS-10011T
Series II ACP blood draw kit (d)	ABS-10012
Centrifuge, Drucker	00389-129-000K
Bucket	03-1-0007-0123HK
Bucket spacer	03-1-0001-0098K
Counterbalance	ABS-10027
Arthrex biologics cart (b) (compatible with both Angel® and ACP centrifuge systems)	ABS-10100

References

1. Scott A, Khan KM, Roberts CR, Cook JL, Durnio V. What do we mean by the term "inflammation"? A contemporary basic science update for sports medicine. *Br J Sports Med.* 2004;38(3):372-380. doi:10.1136/bjism.2004.011312
2. Jiang N, Tan NS, Ho B, Ding JL. Respiratory protein-generated reactive oxygen species as an antimicrobial strategy. *Nat Immunol.* 2007;8(10):1114-1122. doi:10.1038/ni1501

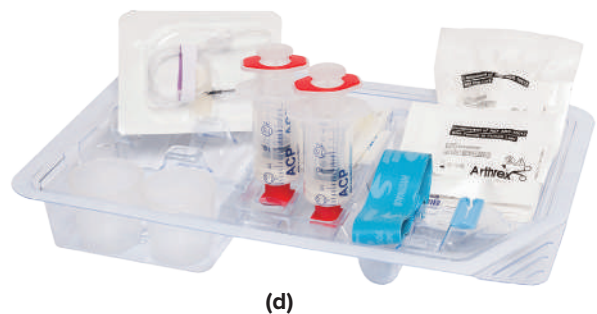

ACP Max™ PRP System

The ACP Max system offers a streamlined approach for the concentration of platelets from whole blood (WB) volumes of 30 mL, 60 mL, or 90 mL. The system's final output results in a neutrophil-poor PRP solution and highly concentrated platelet product compared to baseline.¹⁻³

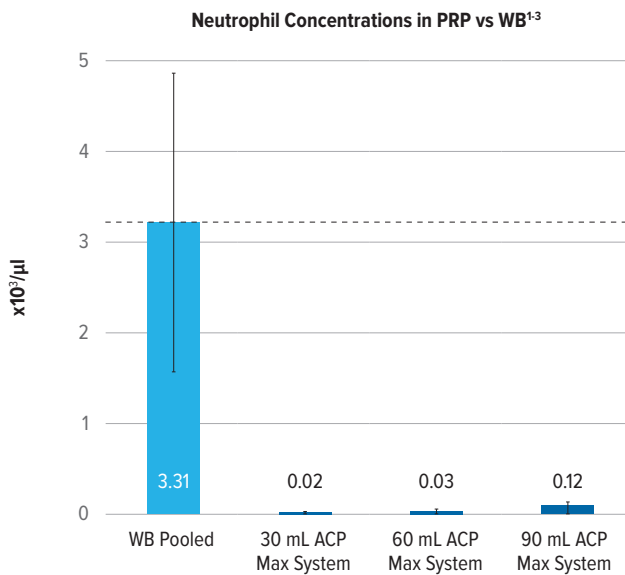
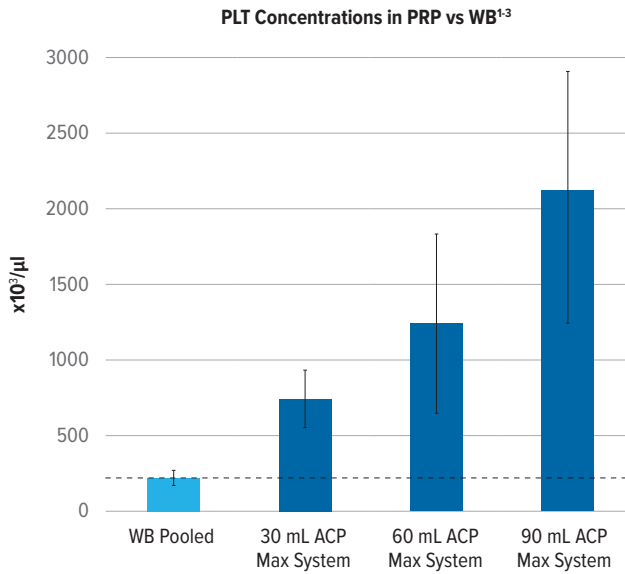

ACP Max PRP system	ABS-10013
ACP Max PRP system (inner tray only)	ABS-10013-B
ACP Max PRP system w/ ACD-A	ABS-10015

References

1. Arthrex, Inc. Data on file (APT-5368). Naples, FL; 2021.
2. Arthrex, Inc. Data on file (APT-5535). Naples, FL; 2022.
3. Arthrex, Inc. Data on file (APT-5756). Naples, FL; 2022.

ACPMAX™

Angel® cPRP System



The Angel cPRP system is the only fully automated system that utilizes 3-sensor technology (3ST) and one-button automation to prepare customized formulations of PRP from whole blood or bone marrow aspirate (BMA). It can deliver platelet concentrations up to 18× over baseline with adjustable leukocyte concentrations.

- › Flexibility to process either whole blood or BMA
- › Proprietary platelet sensor system
- › Adjustable platelet and white blood count (WBC) concentrations
- › Flexible processing volume from 40 mL to 180 mL
- › Each processing kit can process 3 cycles of up to 180 mL on the same patient
- › Programmable and capable of storing up to 30 custom processing protocols
- › Closed system, delivers PRP, platelet-poor plasma (PPP), and red blood cells (RBCs) into separate, sterile compartments

Angel system centrifuge	ABS-10060
Angel system centrifuge, refurbished	ABS-10060R
Angel PRP kit w/ blood draw components	ABS-10061T
Angel kit	ABS-10063
Arthrex biologics cart	ABS-10100



Bone Marrow Aspiration

Bone marrow is a source of stem cells and progenitor cells that differentiate into a variety of tissues (eg, bone, cartilage, tendon, ligament, fat, muscle, nerve). There has also been discussion that bone marrow stem cells have a role in the maintenance and repair of several other tissues.¹

BMA provides a cell suspension that can be readily processed intraoperatively for immediate implantation. BMA is commonly withdrawn from the vertebral body and iliac crest, but it can also be aspirated from the femur, calcaneus, and humerus. BMA is usually concentrated with the Angel system to remove red blood cells and concentrate other cellular material in a small volume for use at repair site.

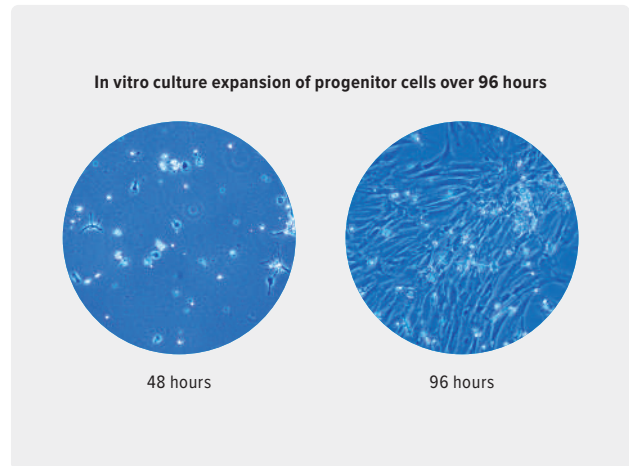

Angel® cPRP System for Bone Marrow Processing	Platelet Concentration (K/mL)	Nucleated Cell Concentration (K/mL)	Hematopoietic Cell Concentration (K/mL)	Total Neutrophil (×10 ⁶)
BMA	87.7 ± 6.4	24.5 ± 15.6	0.002 ± 0.001	612.1
PRP concentrate from BMA	787.0 ± 317.6	240.5 ± 186.6	0.081 ± 0.056	132.9
Increase above baseline	~9×	~10×	~33×	↓80%

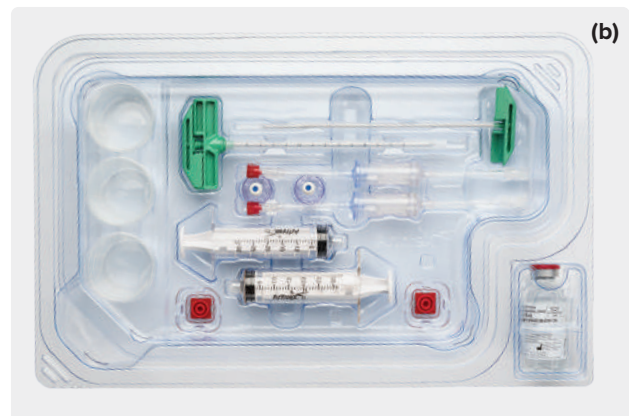
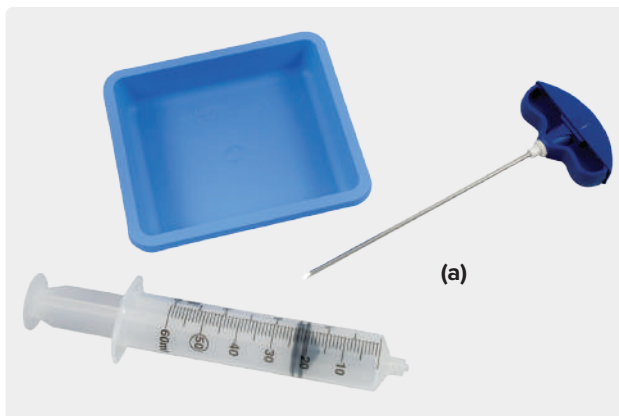

Bone Aspiration Kit

The Bone Aspiration Kit is a convenient, sterile combination of instruments useful for aspirating bone marrow.

Bone aspiration kit (a)	AR-1101DS
<ul style="list-style-type: none"> > 1 bone marrow aspiration needle > 1 syringe, 60 mL > 1 prep tray 	
Angel cPRP system w/ aspiration kit (w/ anticoagulant solution) (b)	ABS-10062T

Reference

- Kramer J, Böhrnsen F, Lindner U, et al. In vivo matrix-guided human mesenchymal stem cells. *Cell Mol Life Sci.* 2006;63(5):616-626. doi:10.1007/s00018-005-5527-z



Vortex™ Threaded Recovery Needle With Angel® cPRP System

Vortex threaded recovery needle	
Threaded BMA needle, 8 ga, closed tip	AR-1101TH-8CT
Threaded BMA needle, 8 ga, open tip	AR-1101TH-8OT
Threaded BMA needle, 13 ga, closed tip	AR-1101TH-13CT
Threaded BMA needle, 13 ga, open tip	AR-1101TH-13OT
Vortex threaded recovery needle kit, 8 ga, open tip	AR-1101THK-8
<ul style="list-style-type: none"> > Vortex threaded recovery needle, 8 ga, open tip > Prep tray > Syringe 	
Vortex threaded recovery needle kit, 13 ga, open tip	AR-1101THK-13
<ul style="list-style-type: none"> > Vortex threaded recovery needle, 13 ga, open tip > Prep tray > Syringe 	
Vortex needle power adapter	AR-1001-TH-PWR
DrillSaw Sports 400™ power system	
Dual trigger rotary drill	AR-01-01-001
Li-ion battery, small	AR-01-03-BP
Hudson modified trinkle reamer attachment	AR-01-02-011
Vortex threaded recovery BMA kit	
BMA processing kit, 8 ga, closed tip, w/o ACD-A	ABS-10062-TH8CT
BMA processing kit, 8 ga, open tip, w/o ACD-A	ABS-10062-TH8OT
BMA processing kit, 13 ga, closed tip, w/o ACD-A	ABS-10062-TH13CT
BMA processing kit, 13 ga, open tip, w/o ACD-A	ABS-10062-TH13OT
Vortex threaded recovery needle Angel kit	
Angel BMA processing kit w/ Vortex threaded recovery needle, 8 ga, closed tip, w/ ACD-A	ABS-10062K-TH8CTA
Angel BMA processing kit w/ Vortex threaded recovery needle, 8 ga, open tip, w/ ACD-A	ABS-10062K-TH8OTA
Angel BMA processing kit w/ Vortex threaded recovery needle, 13 ga, closed tip, w/ ACD-A	ABS-10062K-TH13CTA
Angel BMA processing kit w/ Vortex threaded recovery needle, 13 ga, open tip, w/ ACD-A	ABS-10062K-TH13OTA

The Vortex threaded recovery needle features a unique design that facilitates precise depth and directional control, allowing the user to reposition the tip of the needle easily and accurately within the bone, to optimize bone marrow aspiration. Studies have shown that the first 2 cc of aspiration for any one depth and location have the highest concentration of osteoprogenitor cells.¹

The Vortex needle can be ordered with the Arthrex Angel cPRP processing kit for efficient aspiration from a wide array of orthopedic and spine applications such as a vertebral body, the anterior superior iliac spine (ASIS), the posterior superior iliac spine (PSIS), the calcaneus, the femur, and the humerus.

Reference

1. Martin GJ, Boden SD, Titus L, Scarborough NL. New formulations of demineralized bone matrix as a more effective graft alternative in experimental posterolateral lumbar spine arthrodesis. *Spine*. 1999;24(7):637-645. doi:10.1097/00007632-199904010-00005

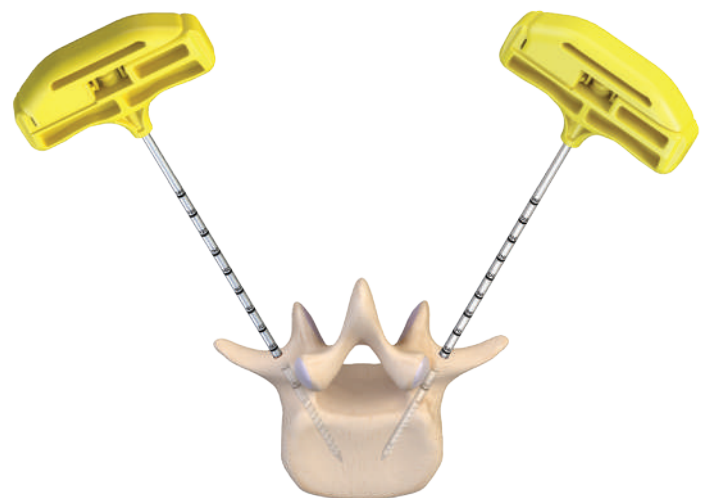
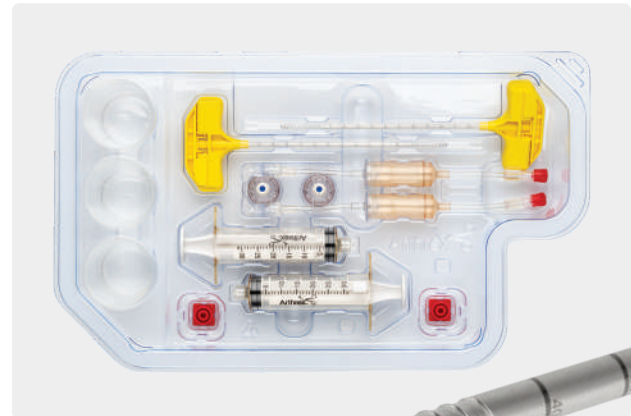

VORTEX
Threaded Bone Marrow Recovery Needle

ARTHREX
angel
SYSTEM

Viscous Delivery Systems

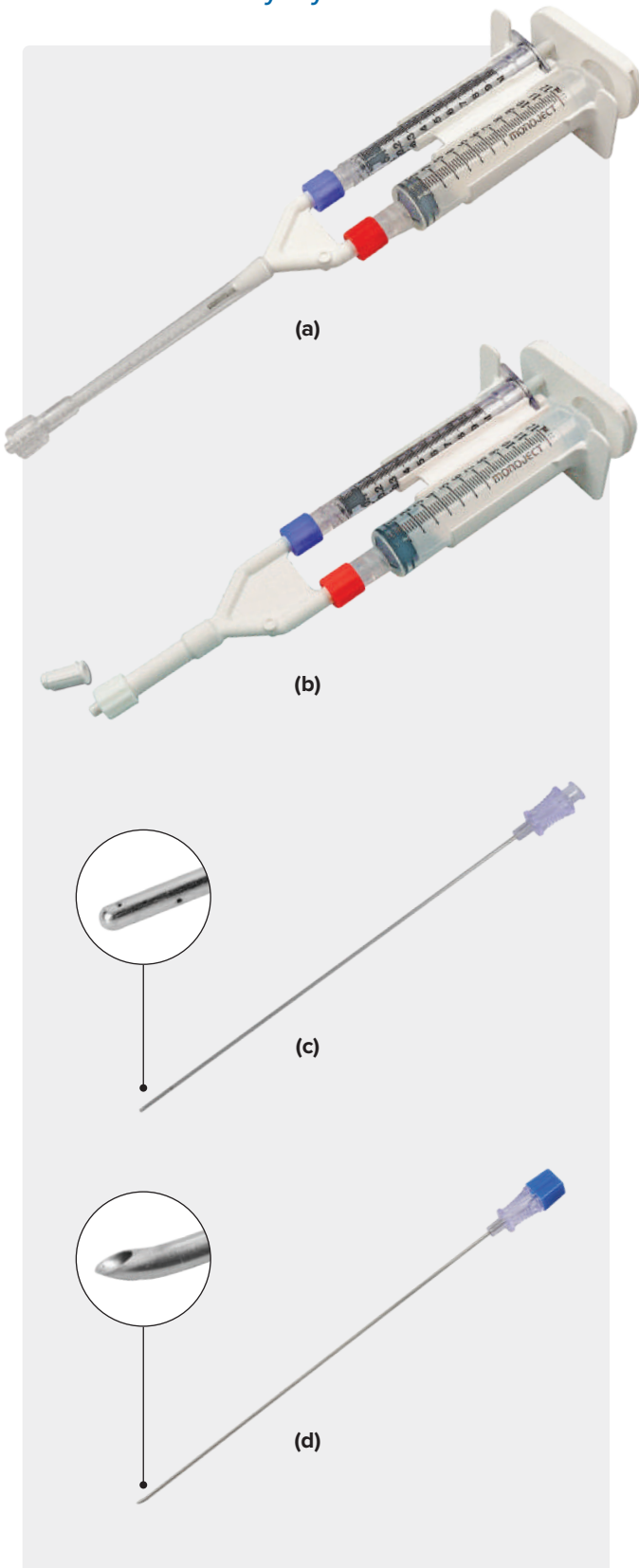

- > Quick and simple to attach and detach
- > Easy to fill—no need to disassemble
- > 11:1 ratio allows homologous mixture of off-the-shelf thrombin or CaCl_2 with autologous fluid
- > Use to provide a low- or high-viscosity fluid
- > Autologous fluid from Arthrex PRP systems can be mixed with allograft or autograft bone prior to application to an orthopedic surgical site as a spray, gel, or clot
- > Extra long, blunt, fenestrated, and beveled delivery needles
- > 1:1 ratio applicators allow homologous mixture of Thrombinator serum with autologous fluids

Viscous-gel applicator, high-viscosity (a)	ABS-10050
Viscous-spray applicator, low-viscosity (b)	ABS-10051
Viscous-spray II applicator, low-viscosity	ABS-10052
Fenestrated delivery needle (c)	ABS-20000
Tuohy delivery needle (d)	ABS-21000
Cannula bending tool	AR-6650
Ratio applicator assembly, 11:1 ratio	SA-1001
Applicator w/ dual spray tips, 11:1 ratio	SA-1060
6 ga × 10 cm (4 in)	SA-3600
20 ga × 5 cm (2 in)	SA-3615
20 ga × 10 cm (4 in)	SA-3618
20 ga × 18 cm (7 in)	SA-3619
Dual cannula semiflexible endoscopic, 32 cm	SA-3650
Dual-spray tip	SA-3660
Blending connector w/ single spray	SA-3674
Applicator procedure kit, 11:1 ratio	SA-4400
Dual spray procedure kit, 11:1 ratio	SA-4460
Applicator assembly, 3 cc, 1:1 ratio	SA-3303

Thrombinator™ System for Use With Arthrex PRP Systems

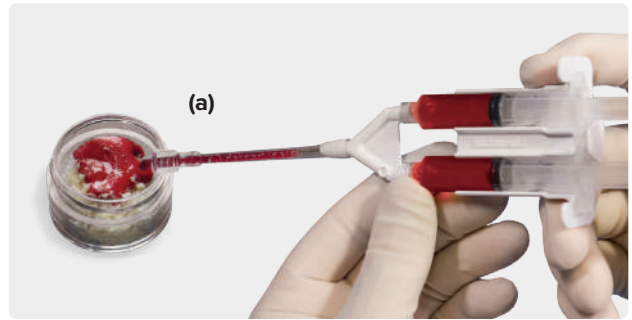

The Thrombinator system for use with PRP is designed to produce an autologous activated serum at the point of care. The serum produced by the Thrombinator system can be used to improve the handling of bone grafts hydrated with PRP or can be mixed with minced osteochondral fragments for the AutoCart™ procedure. Autologous activated serum improves handling by activating the clotting cascade through the production of thrombin. The Thrombinator process uses the principles of the clotting cascade to produce an activated serum without the use of harsh chemical reagents such as ethanol. The Thrombinator design eliminates the need for lengthy incubation times and heating requirements. Autologous activated serum can be produced in less than 20 minutes from peripheral (whole) blood, platelet-poor plasma (PPP), or PRP at the point of care.

By its ability to activate platelets to produce a gel that serves as a binding agent, autologous activated serum can be used to improve the handling of bone grafts hydrated with PRP.

- > Rapid preparation, less than 20 minutes
- > Prepare from WB, PPP, or PRP
- > Produces clot in as little as 15 seconds
- > Centrifugation not required

Thrombinator system for use with the Angel® cPRP system	ABS-10080
Accessories	
Dual-cannula semiflexible endoscopic, 32 cm	SA-3650
Applicator assembly 10 cc, 1:1 ratio	SA-3310
Dual-spray tip	SA-3660
Blending connector w/ single spray	SA-3674
Blending connector w/ mixer (a)	SA-3678



AutoPose™ System for Adipose Tissue Harvesting

The AutoPose system enables the safe and rapid preparation of autologous microfragmented adipose tissue (MFAT) for injection. AutoPose Access assists with harvesting of adipose tissue, while the dual-chamber AutoPose Restore syringe is used to aspirate, concentrate, and resize. The resulting washed autologous MFAT provides cushioning and support to facilitate natural healing of damaged or injured tissues.

Features and Benefits

AutoPose Access

AutoPose Access is a sterile, single-use device that guides the safe harvest of autologous adipose tissue. The Access device utilizes a sterile vacuum cavity to lift and immobilize the dermis. A retractable piercing needle facilitates introduction of the AutoPose Restore dual-syringe cannula used to harvest tissue.

- › Vacuum regulator eliminates the need to control vacuum pressure
- › Minimally invasive piercing needle eliminates the need for an incision or suture
- › Ensures uniform introduction of harvesting cannula through immobilized dermis at a depth of 1 cm
- › Articulating arm guides tissue harvest

AutoPose Restore Syringe

The AutoPose Restore dual-chamber syringe is a sterile, single-use syringe intended for harvesting, concentrating, and transferring resized adipose tissue. The Restore syringe can be used alone or in conjunction with the AutoPose Access device to harvest a sample of adipose tissue.

- › Dual-chamber syringe enables harvesting, purification, and microsizing of fat within a closed system, minimizing risk of environmental contaminants
- › Harvesting cannula compatible with piercing needle of the AutoPose Access for controlled harvesting of adipose tissue 1 cm below the skin surface
- › Vacuum-lock syringe assists with tissue harvest
- › Adipose resized through an 800-micron filter is suitable for delivery through 18- to 21-ga injectors
- › Gentle processing preserves viability of the graft tissue

AutoPose Restore Syringe Stand

The AutoPose Restore syringe stand is used along with the AutoPose Restore dual-chamber syringe for concentrating, washing, and transferring of autologous fat tissue.

- › Reusable
- › Can be sterilized with steam or a germicide
- › Accommodates both the AutoPose Restore syringe and up to four 1 cc injection syringes
- › Holds the AutoPose Restore syringe in a fixed position during decantation and resizing

AutoPose access (a)	ABS-101024-1
AutoPose restore syringe (b)	ABS-101035-1
AutoPose syringe stand (c)	101-034-02



Bone Repair

16	ArthroCell™ Viable Bone Matrix
17	ArthroCell Plus™ Viable Bone Matrix
18	AlloSync™ Expand Demineralized Bone Fibers
19	AlloSync™ Pure Demineralized Bone Matrix
20	AlloSync™ Putty, Gel, and Paste
21	BioXpress™ Graft Delivery Device
21	Tuohy Delivery Needles
22	Arthrex Trochanteric Nail Augmentation System
23	AlloSync™ Button
24	AlloSync™ Demineralized Cancellous Sponges, Chips, and Cortical Fibers
25	BioSurge™ Cell and Bone Graft Processing System
25	AlloSync Cancellous Chips, Cubes, and Cancellous Crush
26	AlloSync™ Cotton and Evans Wedges
27	AlloSync™ Bone PIP Dart for Hammertoe Arthrodesis
28	Cannulated Revision Bone Dowels
29	Bone Dowel Revision Kit
30	1 cc BoneSync™ Calcium Phosphate Cement
30	BoneSync™ Fast-Setting, Drillable Calcium Phosphate Cement
31	BoneSync™ Putty and Strips
32	BoneSync™ BioActive Matrix
33	Arthrex Calcium Sulfate BioBeads
34	Quickset™ Calcium Phosphate Cement
35	OSferion Wedges
36	OsteoAuger™ Bone Graft Harvesting System
37	GraftNet™ XL Bone Collection Device

ArthroCell™ Viable Bone Matrix

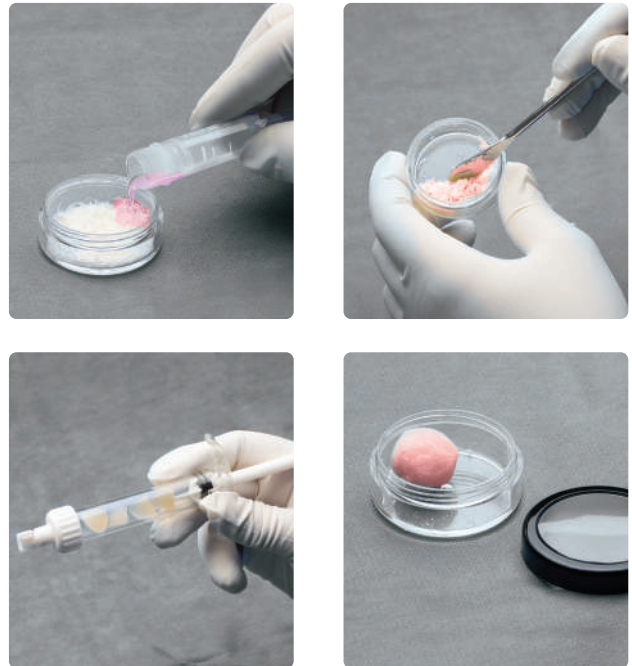

Viable Bone Matrix

ArthroCell viable bone allograft contains cellular, scaffold, and gel components derived from human bone. The cellular component consists of mesenchymal stem, osteoprogenitor, and pluripotent cells.

- > A safe/nonimmunogenic viable allogenic bone matrix intended for use as a bone void filler for bone defects, fusions, and nonunion orthopedic applications
- > Osteogenic, osteoconductive, and osteoinductive potential
- > Final product is moldable for ease of use and optimal handling
- > Novel cryoprotectant (DMSO-free) and noncytotoxic
- > Conveniently store in a cryogenic freezer (-65 °C) for up to 2 years

ArthroCell viable bone matrix, 2.5 cc	ABS-2009-02
ArthroCell viable bone matrix, 5 cc	ABS-2009-05
ArthroCell viable bone matrix, 10 cc	ABS-2009-10
Mixing delivery syringe, 14 cc	ABS-2000



ArthroCell Plus™ Viable Bone Matrix

ArthroCell Plus is a next-generation viable bone graft that extends our current offerings. ArthroCell Plus allograft is delivered in a premixed syringe, with sizes of 1 cc, 2.5 cc, 5 cc, and 10 cc. ArthroCell Plus grafts contain the same novel cryoprotectant as our current ArthroCell graft offering, providing a product with minimal preparation time.

- › Osteogenic, osteoconductive, and osteoinductive potential
- › Final product is moldable for ease of use and optimal handling
- › Novel cryoprotectant (DMSO-free) and noncytotoxic
- › Conveniently store in a cryogenic freezer (-65 °C) for up to 2 years

ArthroCell Plus allograft, 1 cc	ABS-2090-01
ArthroCell Plus allograft, 2.5 cc	ABS-2090-02
ArthroCell Plus allograft, 5 cc	ABS-2090-05
ArthroCell Plus allograft, 10 cc	ABS-2090-10



AlloSync™ Expand Demineralized Bone Fibers



AlloSync Expand fibers, 1 cc	ABS-2017-01
AlloSync Expand fibers, 2.5 cc	ABS-2017-02
AlloSync Expand fibers, 5 cc	ABS-2017-05
AlloSync Expand fibers, 10 cc	ABS-2017-10

The unique geometry of AlloSync Expand 100% demineralized bone is ideal for intraoperative handling and controlled expansion into bone voids. AlloSync Expand fibers come preloaded in a syringe that allows for consistent hydration of the graft with biologic fluids, such as BMA.

100% Demineralized Bone Fibers

- › No added fillers for maximum demineralized bone content and osteoinductive potential
- › Specific fiber geometry provides exceptional handling and controlled expansion
- › Lyophilized fibers extend shelf life while preserving the osteoinductive potential

Expands to Fill Gaps

- › Wicks blood, bone marrow, and other physiological fluids that allow the graft to expand and improve fill

Cellular Highways

- › Fibers have demonstrated superior bone-forming capacity compared to standard particulate demineralized bone matrix¹
- › Entangled fibers create a 3D interconnected matrix that can promote cell migration and fusion

Simplicity of Hydration

- › Luer lock portal delivers a simple yet thorough hydration process
- › Flexibility to select various hydration fluids

Reference

1. CellRight Technologies, LLC. Data on file (ConCelltrate® 100 histology and in-vitro alkaline phosphate induction assay). Universal City, TX; 2017.



ALLOSYNC

AlloSync™ Pure Demineralized Bone Matrix

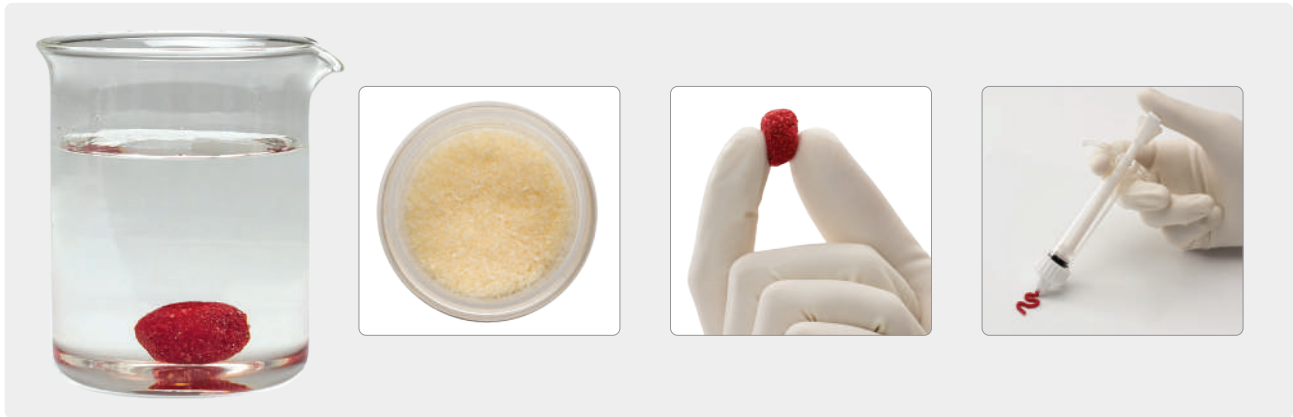

AlloSync Pure osteoinductive demineralized bone matrix (DBM) is derived from 100% human allograft bone with no extrinsic carriers. When prepared, AlloSync Pure DBM resists irrigation and can be used in a fluid environment. The clinician can control the handling properties of AlloSync Pure DBM, which includes decreasing the viscosity for injectable applications or increasing the viscosity to add autograft and/or allograft. The proprietary rice-shaped fiber technology used to process AlloSync Pure DBM increases the osteoinduction and osteoconductive surface area to accelerate cellular ingrowth.¹

- > Derived from 100% human allograft bone without any extrinsic carriers
- > Poststerilization, every lot is tested in vivo to ensure osteoinductivity
- > Demineralization process preserves native bone morphogenetic proteins (BMPs) and growth factors
- > Resists irrigation

- > Histologically proven to contain all 5 elements of bone formation, including new bone, bone marrow, osteocytes, chondrocytes, and cartilage postimplantation at 28 days²
- > May be hydrated with BMA, PRP, blood, saline, or other cellular components
- > Sterile to device-grade standards (10⁻⁶) and stored at ambient temperature
- > Provided in a ready-to-use mixing jar
- > 4 sizes available
- > 5-year shelf life

AlloSync Pure DBM, 1 cc	ABS-2010-01
AlloSync Pure DBM, 2.5 cc	ABS-2010-02
AlloSync Pure DBM, 5 cc	ABS-2010-05
AlloSync Pure DBM, 10 cc	ABS-2010-10

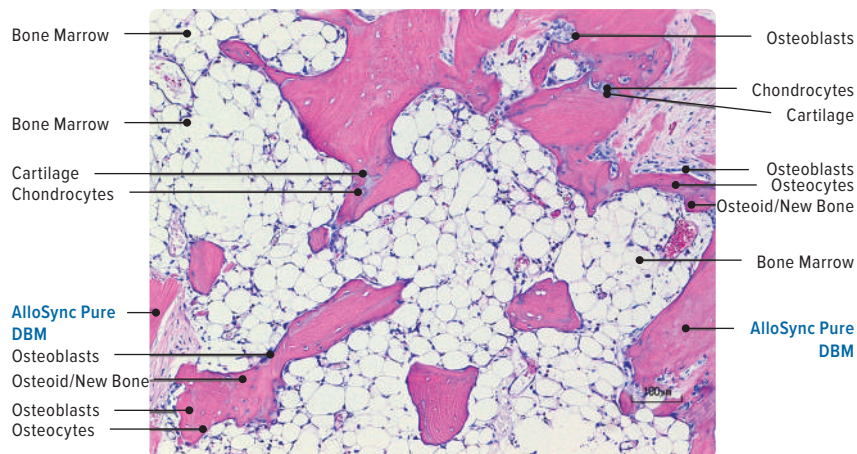

AlloSync Pure demineralized bone matrix histology

References

1. Arthrex, Inc. LA1-000006-en-US_A. Naples, FL; 2019.
2. CellRight Technologies, LLC. Data on file (ConCelltrate™ 100 histology and in-vitro alkaline phosphate induction assay). Universal City, TX; 2017.

ALLOSYNC PURE

AlloSync™ Putty, Gel, and Paste

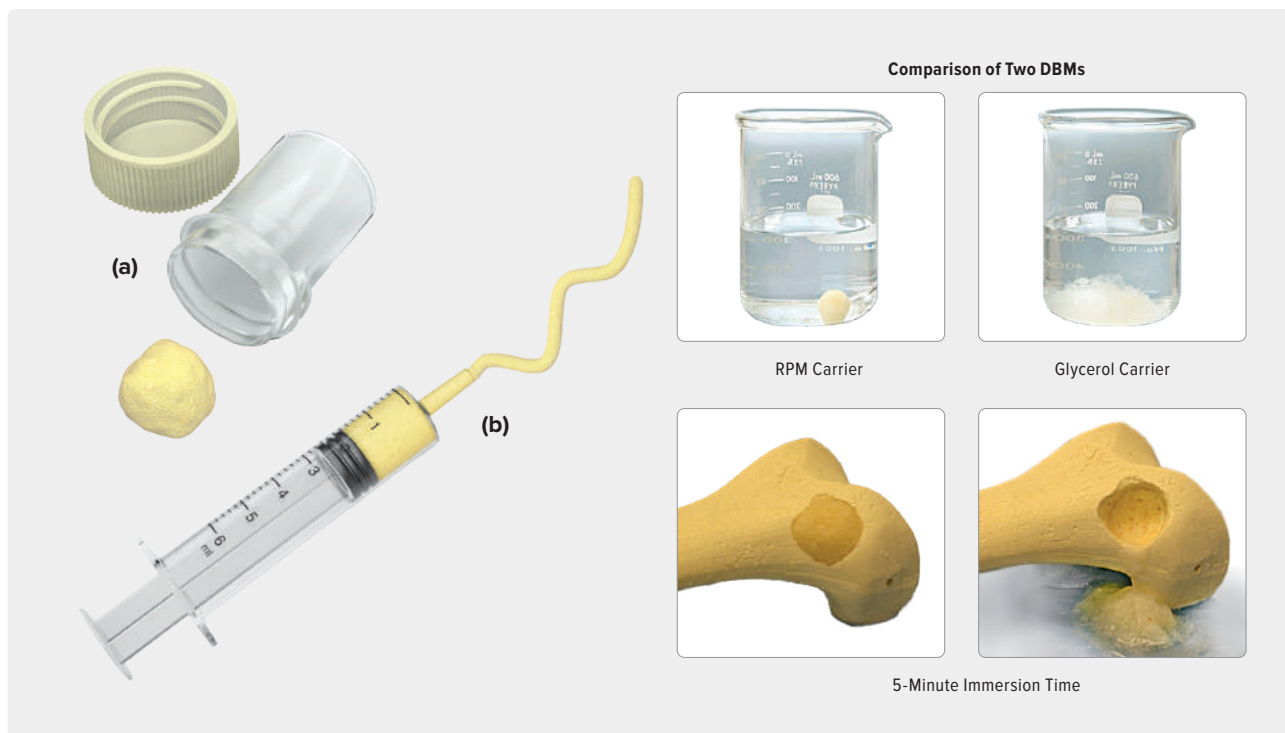

AlloSync Bone Products May Provide Osteoinductive and Osteoconductive Properties

- › Osteoinduction—signaling molecules such as BMPs that aid in cell differentiation down osteoblastic pathways
- › Every lot of DBM is tested for osteoinductive potential, using either an in vitro assay or in vivo model
- › Osteoconduction—scaffolding from DBM particles for osteoblasts to form new bone
- › Additional scaffolding properties are provided in AlloSync cancellous bone with the addition of cancellous bone chips

Superior Handling Characteristics via the Reverse-Phase Medium (RPM) Carrier

- › RPM is an inert, biocompatible copolymer consisting of polypropylene oxide and polyethylene oxide
- › Material is flowable at room temperature and thickens to become more viscous at body temperature
- › RPM allows the DBM graft to be moldable and packed into any defect size or shape
- › AlloSync bone products will resist irrigation and can be used in a fluid environment without the fear of graft migration, unlike some other DBMs

AlloSync Bone Products Offer Ease of Use and Terminal Sterility

- › Provided as a ready-to-use, off-the-shelf product that requires no thawing or premixing
- › Terminal sterilization using electron beam results in a sterility assurance level (SAL) of 10^{-6} ; process is not harmful to the DBM or its bioactivity
- › Room temperature storage

AlloSync DBM putty	
Putty, 1 cc (a)	ABS-2012-01
Putty, 2.55 cc	ABS-2012-02
Putty, 5 cc	ABS-2012-05
Putty, 10 cc	ABS-2012-10
AlloSync DBM gel	
Gel, 1 cc (b)	ABS-2013-01
Gel, 5 cc	ABS-2013-05
Gel, 10 cc	ABS-2013-10
AlloSync CB DBM putty	
Putty, 5 cc	ABS-2014-05
Putty, 10 cc	ABS-2014-10
AlloSync CB DBM paste	
Paste, 1 cc	ABS-2015-01
Paste, 3 cc	ABS-2015-03
Paste, 8 cc	ABS-2015-08

ALLOSYNC

BioXpress™ Graft Delivery Device

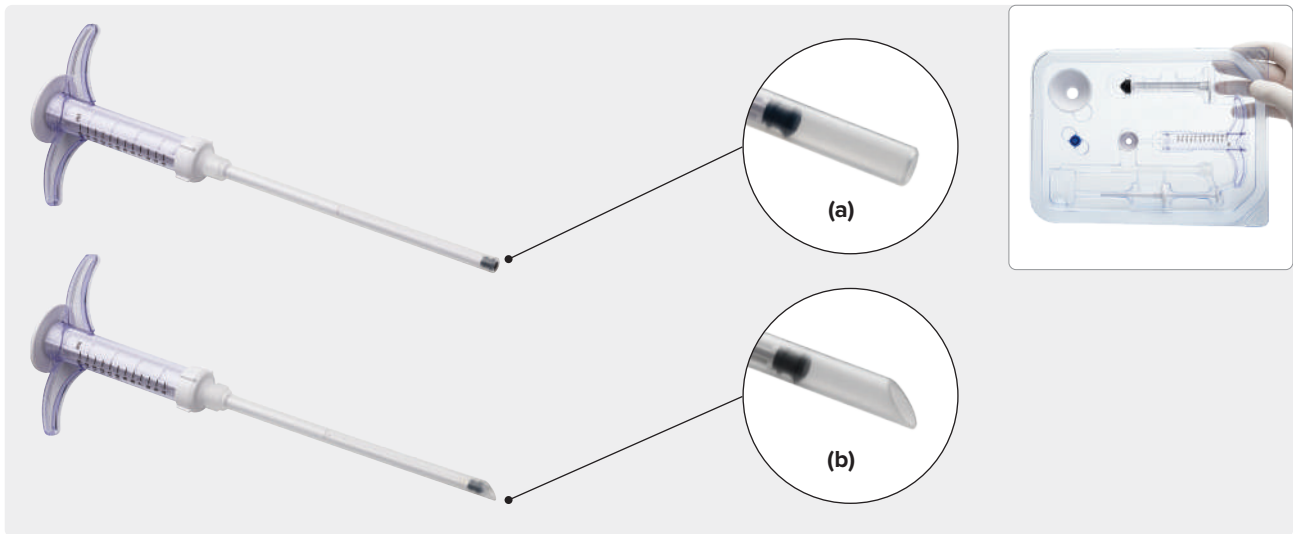

The BioXpress graft delivery device is designed for targeted delivery of hydrated allograft, autograft, or synthetic bone graft materials to an orthopedic surgical site while maximizing material use.

Blunt tip cannula, 10 cm (a)	ABS-10053-10
Angled tip cannula, 10 cm (b)	ABS-10053-10-45
Blunt tip cannula, 15 cm	ABS-10053-15
Angled tip cannula, 15 cm	ABS-10053-15-45



Tuohy Delivery Needles

Tuohy delivery needles are a versatile and easy-to-use solution for bone graft delivery. The 45° curved tip provides control and facilitates the delivery of hydrated allograft, autograft, or synthetic bone graft materials, particularly in harder-to-reach angled areas.

Tuohy needle w/ obturator	ABS-1001
Tuohy needle, long	ABS-1001-L
Tuohy needle, short	ABS-1001-S



Arthrex Trochanteric Nail Augmentation System



The Arthrex Trochanteric Nail Augmentation System is designed for precise delivery of bone graft to the bone surrounding the lag screw of the trochanteric nail. A variety of allograft or synthetic bone graft products can be delivered to help promote bone remodeling and repair.

Kit components include:

- > 3.2 mm guide pin
- > Delivery cannula
- > Three 1 cc syringes
- > Female-to-female Luer

These components aid in ensuring precise and efficient delivery of bone graft to the peripheral bone.

Arthrex Trochanteric Nail Augmentation System

ABS-1094



AlloSync™ Button



The AlloSync button is a 12 mm (round) × 3 mm (thick) demineralized cancellous bone disc. This disc maintains the same superior handling characteristics as the AlloSync demineralized cancellous sponges. The compressible nature of this graft allows it to be delivered to a repair site through an arthroscopic portal.

AlloSync button, 12 mm × 3 mm

ABS-2011

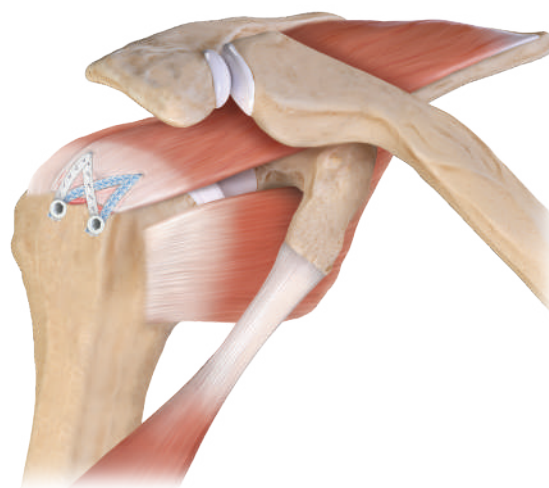
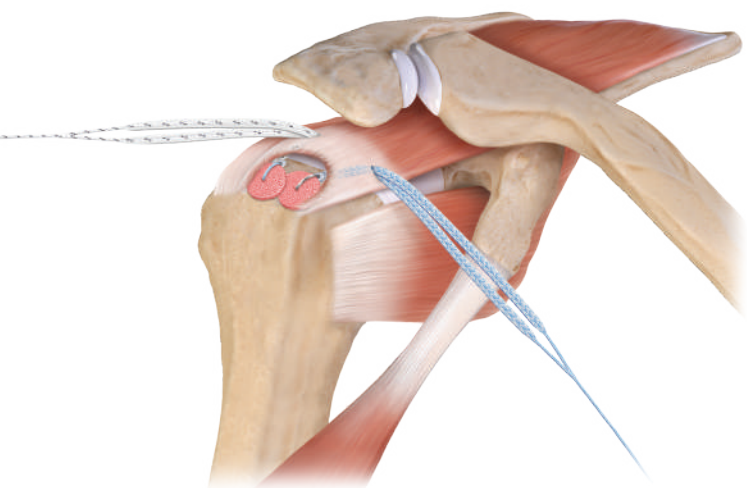

AlloSync™ Demineralized Cancellous Sponges, Chips, and Cortical Fibers

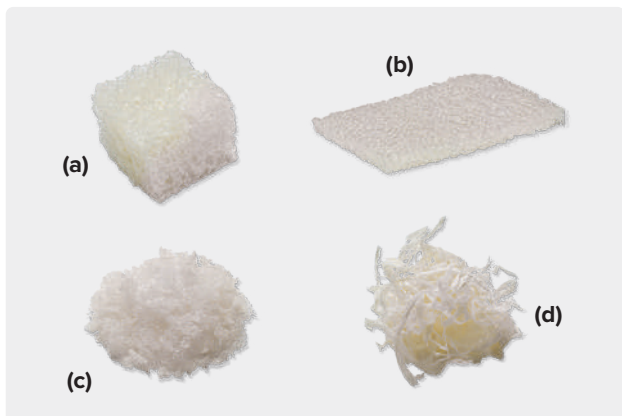

AlloSync demineralized strip used to augment an ankle arthrodesis procedure

Cancellous Sponges

Cubes	
Cube, 8 mm × 8 mm × 8 mm (a)	ABS-2005-01
Cube, 10 mm × 10 mm × 10 mm	ABS-2005-02
Cube, 12 mm × 12 mm × 12 mm	ABS-2005-03
Strips	
Strip, 10 mm × 10 mm × 3 mm (b)	ABS-2006-01
Strip, 15 mm × 40 mm × 3 mm	ABS-2006-02
Strip, 26 mm × 19 mm × 7 mm	ABS-2006-03
Strip, 10 mm × 20 mm × 7 mm	ABS-2006-04
Chips	
Chips (1 mm-4 mm), 1 cc (c)	ABS-2007-01
Chips (1 mm-4 mm), 2.5 cc	ABS-2007-02
Chips (1 mm-4 mm), 5 cc	ABS-2007-03
Cortical fibers	
Fibers, 1 cc (d)	ABS-2008-01
Fibers, 2.5 cc	ABS-2008-02
Fibers, 5 cc	ABS-2008-03
Fibers, 10 cc	ABS-2008-04

Cancellous Sponges

- › Poststerilization, every lot is tested in vivo to ensure osteoinductivity
- › Demineralized cancellous matrix is comprised of 100% cancellous bone
- › Maintains natural bone architecture with interconnected porosity
- › Provides optimal scaffold for cellular attachment and proliferation
- › Contains exposed natural growth factors with verified osteoinductivity¹
- › Naturally absorbs and retains bioactive fluids like PRP and BMA
- › After rehydration, the product is compressible like a sponge, allowing for flexibility to fit in and around different types of bone defects
- › Sterile to device-grade standards (10⁻⁶) and stored at ambient temperature

Demineralized Cortical Fibers

- › New form of 100% DBM offering excellent handling characteristics without the need for an additional carrier
- › Osteoconductive and verified osteoinductive properties¹
- › The cortical fibers are demineralized using a proprietary process, optimizing the residual calcium level and osteoinductivity
- › Demineralized cortical fibers provide an optimal scaffold for cellular attachment and proliferation
- › Customizable hydration—naturally wicks up bioactive fluids such as PRP and concentrated BMA
- › Sterile to device-grade standards (10⁻⁶) and stored at ambient temperature

Reference

1. CellRight Technologies, LLC. Data on file (ConCelltrate® 100 histology and in-vitro alkaline phosphate induction assay). Universal City, TX; 2017.

BioSurge™ Cell and Bone Graft Processing System

The BioSurge cell and bone graft processing system combines the superior matrices of the AlloSync™ bone grafting solutions line with the Angel® system's proprietary technology to prepare customized PRP concentrate from BMA. Hydrated AlloSync bone grafts provide the optimal scaffold for cPRP from BMA, which is a rich source of platelets, nucleated cells, and progenitor cells.

BioSurge I, 2.5 cc AlloSync pure w/ Angel cPRP and BMA tray	ABS-2016-01
BioSurge II, 5 cc AlloSync pure w/ Angel cPRP and BMA tray	ABS-2016-02
BioSurge III, 15 mm × 40 mm × 3 mm AlloSync DBM cancellous strip w/ Angel cPRP and BMA tray	ABS-2016-03
BioSurge V, 12 mm × 3 mm AlloSync button disc w/ Angel cPRP and BMA tray	ABS-2016-05

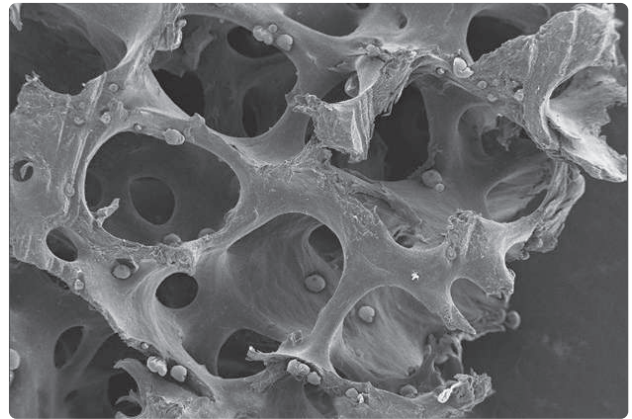

Electron microscopy image showing many healthy cells attached to the AlloSync bone graft scaffold after hydration.



AlloSync Cancellous Chips, Cubes, and Cancellous Crush



AlloSync cancellous cubes, chips, and cancellous crush provide an osteoconductive scaffold for bone ingrowth and allow for remodeling with the patient's own bone. AlloSync cancellous bone grafts are available in multiple sizes and quantities.

AlloSync cancellous cubes	
AlloSync cancellous cube, 15 cc	ABS-2900-15
AlloSync cancellous cube, 30 cc	ABS-2900-30
AlloSync cancellous chips	
AlloSync cancellous (1 mm-4 mm) chips, 5 cc	ABS-2901-05
AlloSync cancellous (1 mm-4 mm) chips, 15 cc	ABS-2901-15
AlloSync cancellous (1 mm-4 mm) chips, 30 cc	ABS-2901-30
AlloSync cancellous (4 mm-10 mm) chips, 5 cc	ABS-2910-05
AlloSync cancellous (4 mm-10 mm) chips, 15 cc	ABS-2910-15
AlloSync cancellous (4 mm-10 mm) chips, 30 cc	ABS-2910-30
AlloSync cancellous crush	
AlloSync cancellous crush, 5 cc	ABS-2905-05



AlloSync™ Cotton and Evans Wedges



AlloSync allograft reconstruction wedges are anatomically contoured grafts for Cotton and Evans procedures. These wedges are identical to the shapes and sizes currently provided in the BioSync® titanium wedge line.

- > 100% allograft cancellous bone
- > Dense cancellous bone material harvested from the femoral head, condyles, distal tibia, and talus for added strength during insertion
- > Sterile to device-grade standards (10^{-6} SAL)
- > Ambient temperature storage
- > Grafts are stored hydrated in saline solution
- > 4-year shelf life

AlloSync Wedges

AlloSync Cotton wedges

16 mm × 4.5 mm (a)	ABS-2800-1645
16 mm × 5.5 mm	ABS-2800-1655
16 mm × 6.5 mm	ABS-2800-1665
16 mm × 7.5 mm	ABS-2800-1675
20 mm × 4.5 mm	ABS-2800-2045
20 mm × 5.5 mm	ABS-2800-2055
20 mm × 6.5 mm	ABS-2800-2065
20 mm × 7.5 mm	ABS-2800-2075

AlloSync Evans wedges

18 mm × 18 mm × 6.5 mm	ABS-2810-1806
18 mm × 18 mm × 8 mm	ABS-2810-1808
18 mm × 18 mm × 10 mm	ABS-2810-1810
18 mm × 18 mm × 12 mm	ABS-2810-1812
20 mm × 20 mm × 6.5 mm	ABS-2810-2006
20 mm × 20 mm × 8 mm	ABS-2810-2008
20 mm × 20 mm × 10 mm	ABS-2810-2010
20 mm × 20 mm × 12 mm	ABS-2810-2012
22 mm × 22 mm × 6.5 mm	ABS-2810-2206
22 mm × 22 mm × 8 mm	ABS-2810-2208
22 mm × 22 mm × 10 mm	ABS-2810-2210
22 mm × 22 mm × 12 mm	ABS-2810-2212

AlloSync™ Bone PIP Dart for Hammertoe Arthrodesis



The AlloSync bone dart implant is a biologic alternative to traditional hammertoe implants. Made from allograft bone, AlloSync bone dart implants provide an optimal scaffold for bone incorporation and may reduce the potential complications of future hardware removal from hammertoe PIP arthrodesis.

AlloSync bone dart implants were manufactured with numerous design characteristics to make them effective and easy to use. The reversed barbs were created to ensure the implant stays in place. Tapered ends and a depth mark were incorporated into the design to make implantation easier. Soaking the implant in ACP/PRP or BMA will allow for the patient's own growth factors and cells to assist with the healing process.

AlloSync bone dart, 3 mm × 22 mm	ABS-2802
AlloSync bone dart disposables kit	ABS-2802DS
<ul style="list-style-type: none"> > 2.5 mm drill bit, cannulated > 2.7 mm drill bit, cannulated > 3 mm drill bit, cannulated > 1.1 mm guidewire > Profile drill > Inserter 	

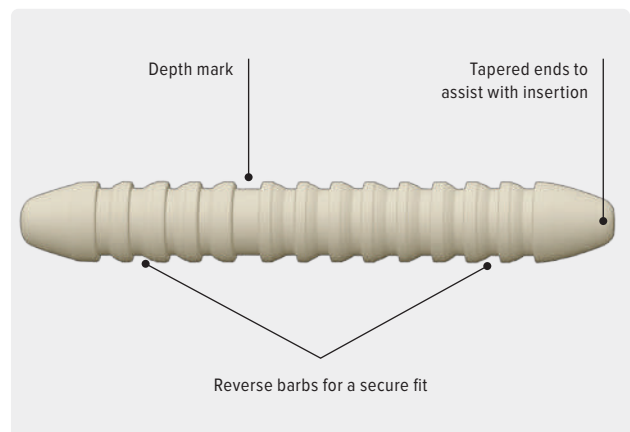

AlloSync Bone Dart Implant

Cannulated Revision Bone Dowels

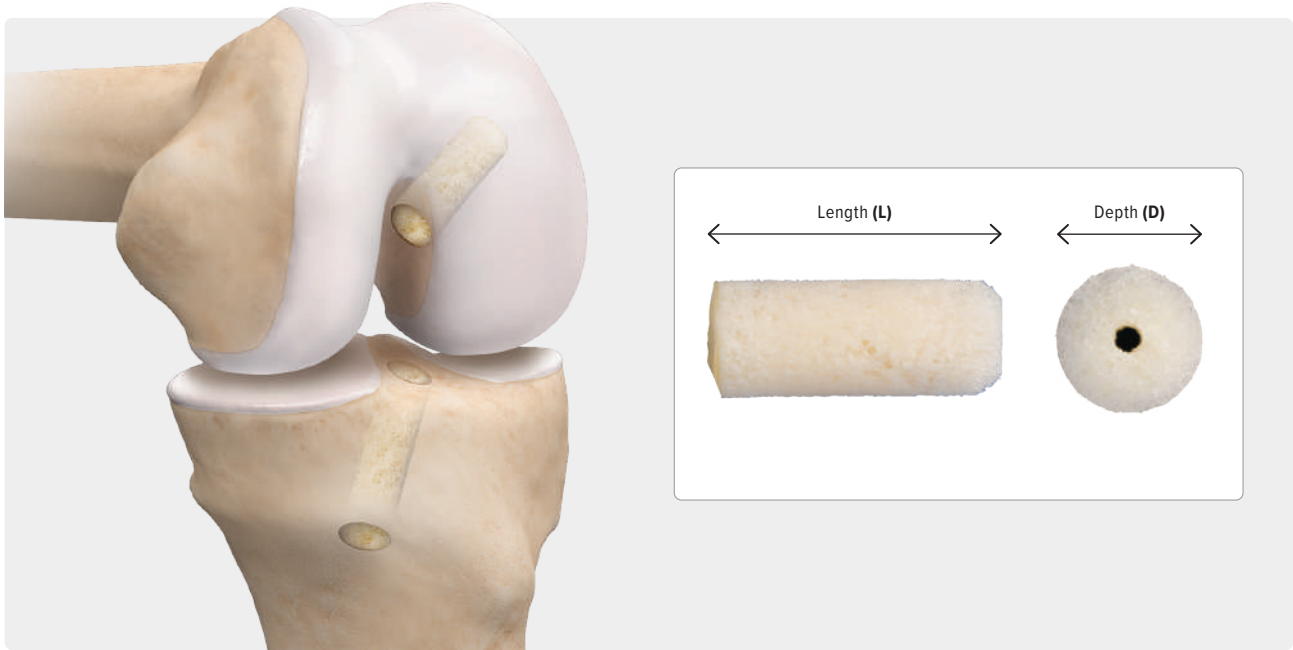

Cannulated revision bone dowels offer surgeons a quick, effective solution for filling bone tunnels during staged ACL/PCL revision cases. They are also an effective solution for filling the bone void in the 1st metatarsal head after the removal of a failed synthetic cartilage implant. The use of bone dowels provides an immediate structural and biologic architecture for stability and incorporation. Soaking the dowels in PRP or BMA infuses growth factors and cells that assist with incorporation of the scaffold.

Cannulated revision bone dowels, treated with the Allowash XG® process to clean the scaffold, are preshaped with a tapered tip and cannulated for easier implantation. Treatment with Preservon® technology allows for the revision bone dowels to be stored in a prehydrated state for up to 5 years.

- > Ready to use
- > Room temperature storage with Preservon technology
- > 5-year shelf life
- > 10^{-6} SAL
- > Cannulated
- > Chamfered tip

Length 25 mm–29 mm

Diameter	LifeNet Health Part No.
9 mm	PCD9
10 mm	PCD10
11 mm	PCD11
12 mm	PCD12
13 mm	PCD13
14 mm	PCD14
16 mm	PCD16
18 mm	PCD18
20 mm	PCD20
22 mm	PCD22

Length 30 mm–35 mm

Diameter	LifeNet Health Part No.
9 mm	PCDXL9
10 mm	PCDXL10
11 mm	PCDXL11
12 mm	PCDXL12
13 mm	PCDXL13
14 mm	PCDXL14
16 mm	PCDXL16
18 mm	PCDXL18

Allowash XG and Preservon are registered trademarks of LifeNet Health.



Bone Dowel Revision Kit

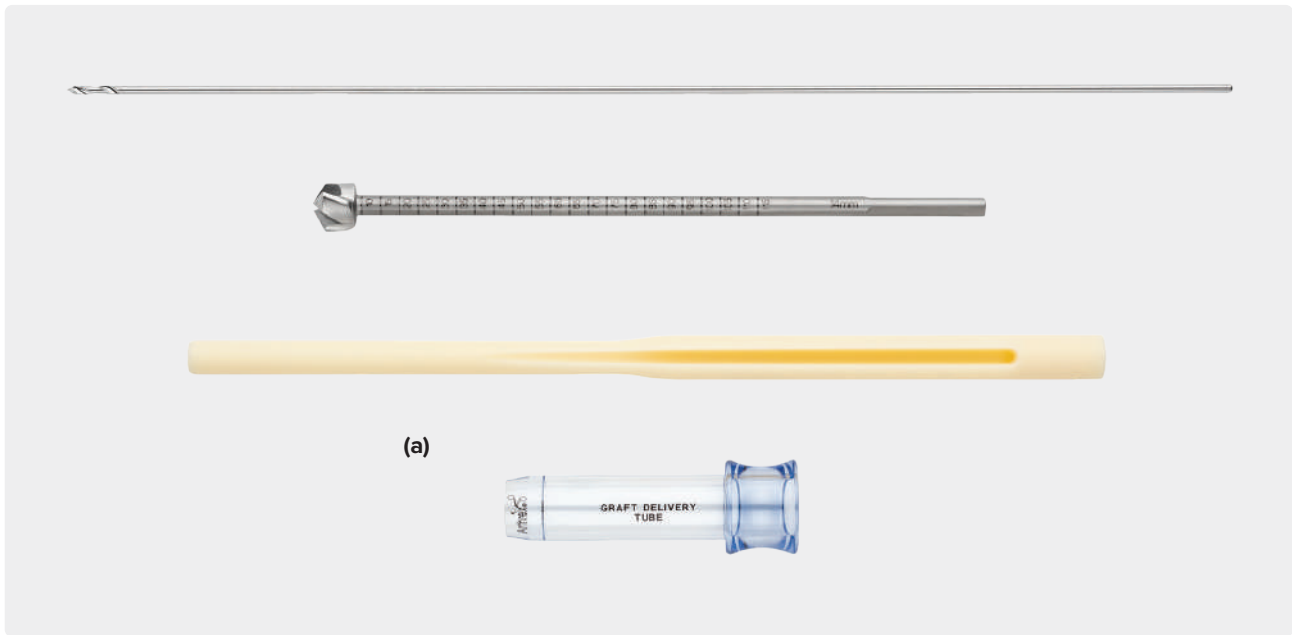

The Arthrex cannulated bone dowel kit simplifies bone tunnel restoration for revision procedures by combining properly sized reamers and a cannulated bone tamp in a single-use kit. The bone tamp was designed for use with a guide pin to allow for proper placement of the cannulated bone dowels into bone tunnels. Using allograft bone dowels to fill bone voids allows for the immediate management of widened tunnels and cystic bone areas.¹ It is estimated that between 1.8% and 10.4% of patients with an ACL reconstruction will require a revision.² Restoration of widened tunnels can be challenging, sometimes requiring a two-stage approach.³ Favorable outcomes have been reported for patients undergoing single-stage ACL reconstruction using allograft bone dowels.⁴

Bone dowel revision kit, 9 mm	ABS-2850-09
Bone dowel revision kit, 10 mm	ABS-2850-10
Bone dowel revision kit, 11 mm	ABS-2850-11
Bone dowel revision kit, 12 mm	ABS-2850-12
Bone dowel revision kit, 13 mm	ABS-2850-13
Bone dowel revision kit, 14 mm (a)	ABS-2850-14
Bone dowel revision kit, 16 mm	ABS-2850-16
Bone dowel revision kit, 18 mm	ABS-2850-18

Kits contain a cannulated bone tamp, 2.4 mm guide pin, delivery tube, and cannulated reamer.

References

1. Demyttenaere J, Claes S, Bellemans J. One-stage revision anterior cruciate ligament reconstruction in cases with excessive tunnel osteolysis. Results of a new technique using impaction bone grafting. *Knee*. 2018;25(6):1308-1317. doi:10.1016/j.knee.2018.08.015
2. MARS Group, Ding DY, Zhang AL, et al. Subsequent surgery after revision anterior cruciate ligament reconstruction: rates and risk factors from a multicenter cohort. *Am J Sports Med*. 2017;45(9):2068-2076. doi:10.1177/0363546517707207
3. Richter DL, Werner BC, Miller MD. Surgical pearls in revision anterior cruciate ligament surgery. When must I stage? *Clin Sports Med*. 2017;36:173-187. doi:10.1177/0363546517707207
4. Werner BC, Gilmore CJ, Hamann JC, et al. Revision ACL reconstruction: results of a single-stage approach using allograft dowel bone grafting for femoral defects. *J Am Acad Orthop Surg*. 2016;24(8):581-587. doi:10.5435/JAAOS-D-15-00572

1 cc BoneSync™ Calcium Phosphate Cement

Adding to the size offerings of BoneSync calcium phosphate cement, this 1 cc option is delivered in a kit that includes all components needed for an efficient mixing and application workflow. This size is an ideal option for for augmenting poor-quality bone surrounding the lateral-row anchors during rotator-cuff repairs or supporting the bone repair process for small-bone fractures.

BoneSync cement, 1 cc

ABS-3101

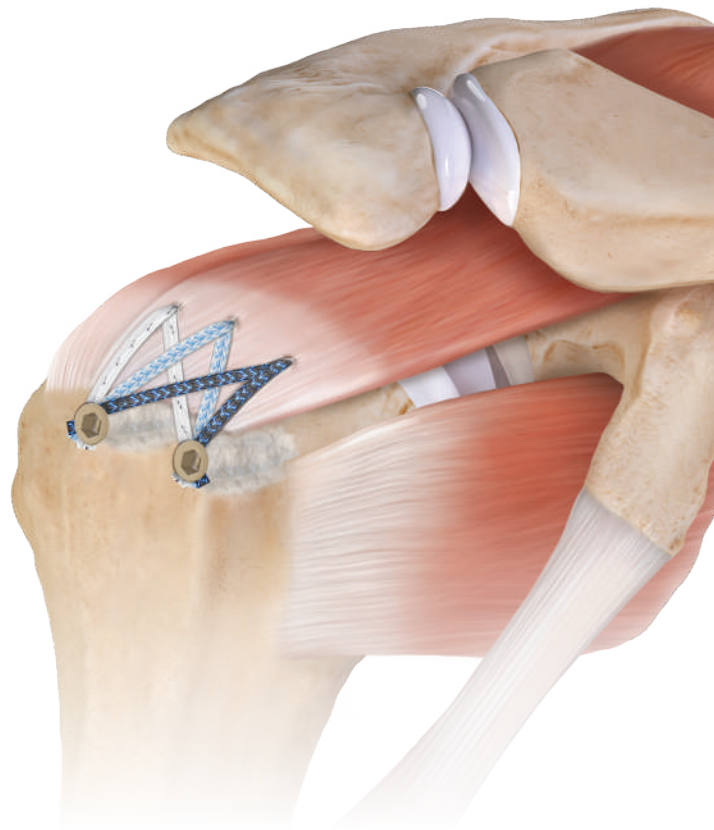

BoneSync™ Fast-Setting, Drillable Calcium Phosphate Cement

BoneSync kit package (a)

BoneSync cement, 3 cc	ABS-3103
BoneSync cement, 5 cc	ABS-3105
BoneSync cement, 10 cc (2× 5 cc kit) (a)	ABS-3105-2



BoneSync cement is a fast-setting, synthetic bone void filler that sets within 5 to 8 minutes, depending on whether it's prepared with saline, blood, or bone marrow.

- > BoneSync bone void filler is provided in a self-contained mixing and delivery system to decrease preparation time and improve delivery
- > BoneSync cement may be mixed with saline, blood, or BMA
- > BoneSync cement is fast-setting to allow immediate supplemental fixation or to add strength to the surgical repair site
- > Following curing, BoneSync cement is drillable to assist fracture repair and fixation
- > Final product expands to improve contact forces with surrounding bone and/or plates or screw fixation
- > BoneSync bone void filler is a resorbable bone cement

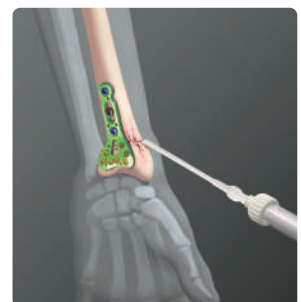

BONESYNC

BoneSync™ Putty and Strips

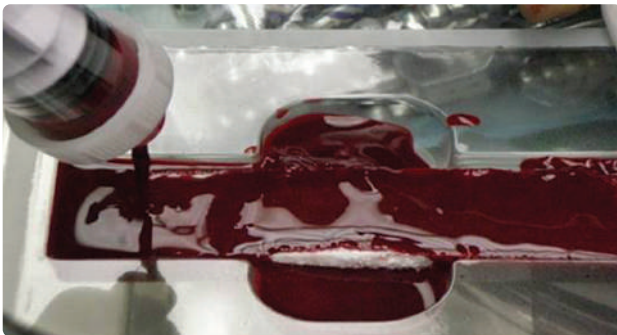

The blend of 20% type I collagen and 80% highly purified beta-tricalcium phosphate (β -TCP) in BoneSync putty and strips provides an osteoconductive material for bone regeneration. It was developed to resemble the composition and pore structure of natural human bone.¹

Benefits of the Collagen-Engineered Matrix in Orthopedic Applications

- > Specifically engineered to provide a scaffold with porosity
- > Facilitates incorporation of cells in BMA and tissue cells during the healing process²
- > BoneSync collagen is composed of highly purified type I collagen, the most abundant type of collagen found in bone
- > Purification and biocompatibility minimizes the potential for immune response
- > Can be hydrated with biologic fluids, such as BMA

BoneSync putty

Putty, 2.5 cc	ABS-3202
Putty, 5 cc	ABS-3205
Putty, 10 cc	ABS-3210
Putty, 15 cc	ABS-3215

BoneSync strips

Strip, 10 cc	ABS-3310
Strip, 15 cc	ABS-3315

References

1. Mataragas, N. Integra LifeSciences. Data on file (Radiographic analysis of fusion success with Integra Collagen Ceramic Matrix, as compared to autograft use, in posterolateral lumbar spine arthrodesis). Princeton, NJ; 2010.
2. Geiger M, Li RH, Friess W. Collagen sponges for bone regeneration with rhBMP-2. *Adv Drug Deliv Rev.* 2003;55:1613-1629.

BONESYNC

BoneSync™ BioActive Matrix

BoneSync BioActive is a second-generation bone void filler that includes bioglass 45S5 and provides an osteoconductive and osteostimulative matrix.¹ BoneSync BioActive bone void filler is available in putty and strip versions to fit various application needs. BoneSync BioActive filler is comprised of 50% carbonate apatite anorganic bone mineral, 30% 45S5 bioactive glass, and 20% Type I collagen. BoneSync BioActive was developed to resemble the composition and pore structure of natural human bone.^{2,3} The synthetic bone void filler is slowly resorbed and replaced by new bone tissue during the healing process.

BoneSync BioActive matrix strip, 5 cc	ABS-3500-05
BoneSync BioActive matrix strip, 10 cc	ABS-3500-10
BoneSync BioActive matrix strip, 20 cc	ABS-3500-20
BoneSync BioActive matrix strip, 40 cc	ABS-3500-40
BoneSync BioActive matrix strip, 2.5 cc	ABS-3400-02
BoneSync BioActive matrix strip, 5 cc	ABS-3400-05
BoneSync BioActive matrix strip, 10 cc	ABS-3400-10
BoneSync BioActive matrix strip, 20 cc	ABS-3400-20

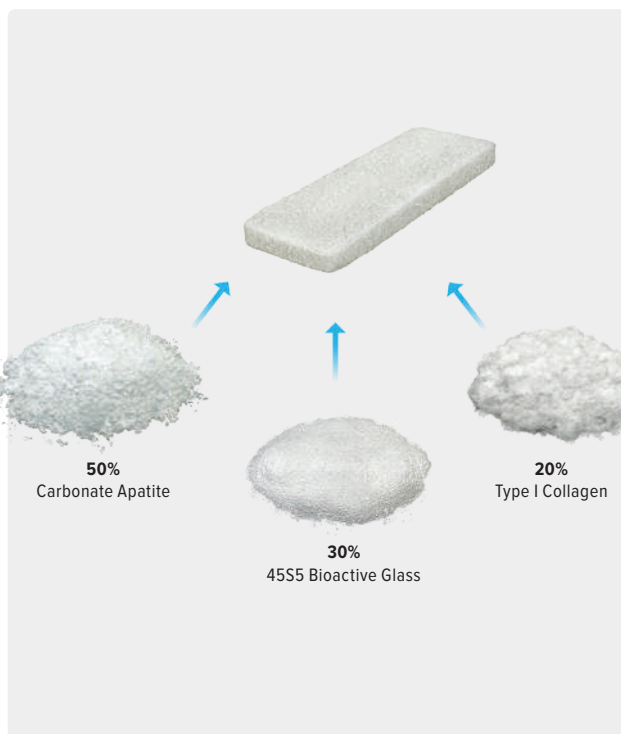
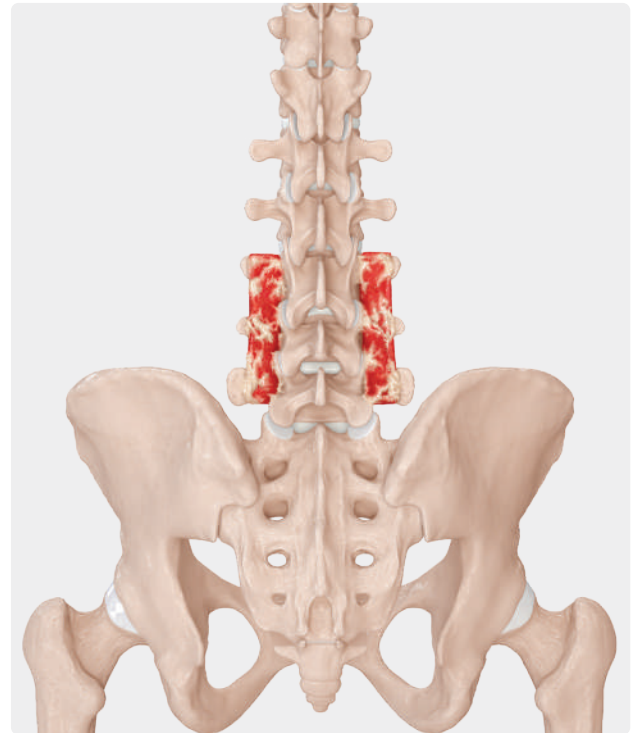

References

1. Hench LL, Polak JM, Xynos ID, Buttery LDK. Bioactive materials to control cell cycle. *Mater Res Innov.* 2000;3(6):313-323. doi:10.1007/s100190000055
2. Matsuura A, Kubo T, Doi K, et al. Bone formation ability of carbonate apatite-collagen scaffolds with different carbonate contents. *Dent Mater J.* 2009;28(2):234-242. doi:10.4012/dmj.28.234
3. Ellies LG, Carter JM, Natiella JR, Featherstone JD, Nelson DG. Quantitative analysis of early in vivo tissue response to synthetic apatite implants. *J Biomed Mater Res.* 1988;22(2):137-148. doi:10.1002/jbm.820220206

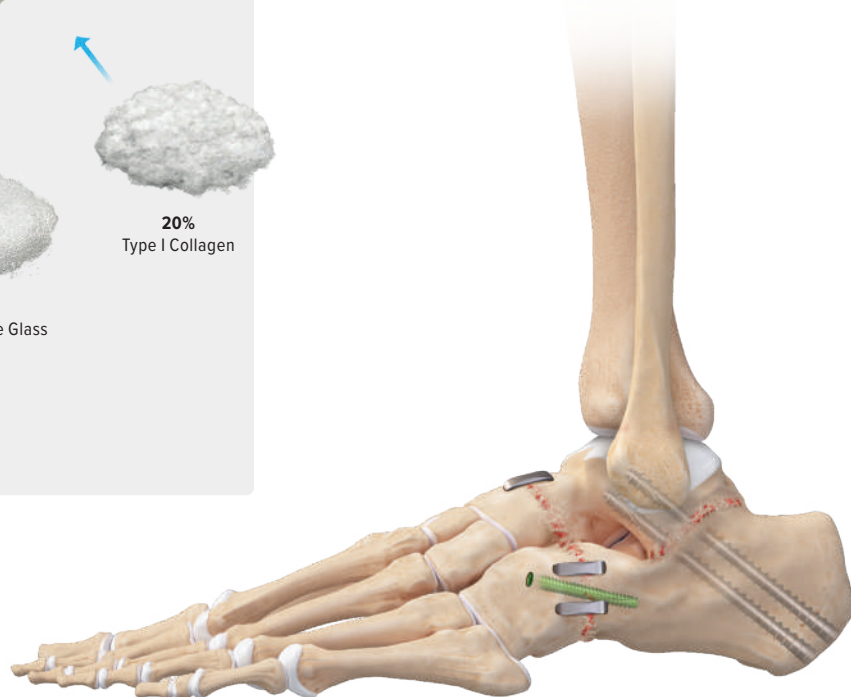

BONESYNC
BIOACTIVE

Arthrex Calcium Sulfate BioBeads

Arthrex Calcium Sulfate (CS) BioBeads provide a high purity, medical-grade calcium sulfate solution that is resorbed and replaced with bone during the repair process. Ideal for filling bony voids, Arthrex CS BioBeads are biocompatible and biodegradable and can be used in infected sites.

Features and Benefits

- › Bead sizes of 3 mm, 4.5 mm, 6 mm, as well as a paste option, for case-by-case flexibility
- › Easy-to-use mixing and delivery kit
- › Fast setting time of 5 minutes
- › Radiopaque for placement visibility

Arthrex CS BioBeads, 5 cc	ABS-3000-05
Arthrex CS BioBeads, 10 cc	ABS-3000-10
Arthrex CS BioBeads, 20 cc	ABS-3000-20

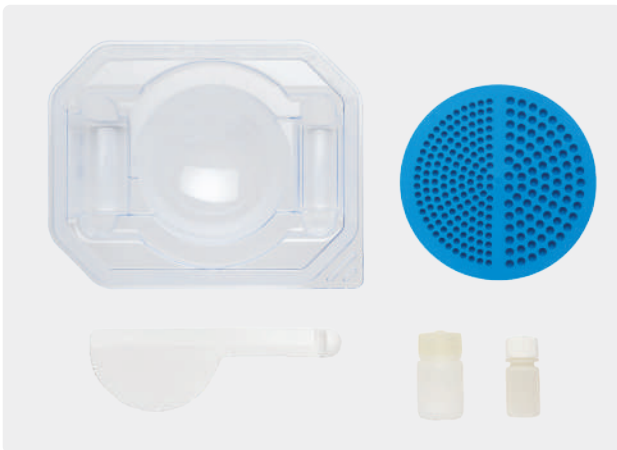

Quickset™ Calcium Phosphate Cement



Quickset cement, 5 cc	ABS-3005
Quickset cement, 8 cc	ABS-3008
Quickset cement, 16 cc	ABS-3016

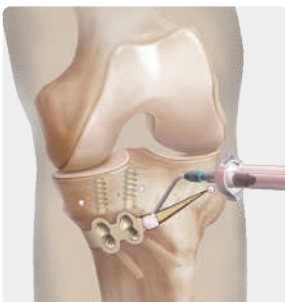

iBalance® HTO

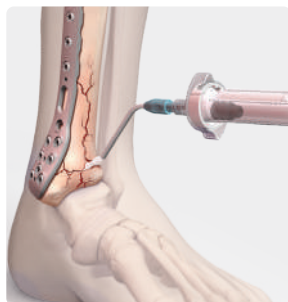

Pilon Fracture



Calcaneus Fracture

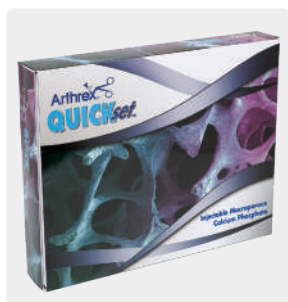

Quickset cement is a macroporous, injectable, hardening, resorbable bone cement provided in an easy-to-use, closed mixing system.

Composition

- › The mixing system is a dual-chambered syringe containing a powder and mixing liquid
- › The powder chamber contains a mixture of calcium phosphates and an organic polysaccharide polymer; the polysaccharide is a highly biocompatible polymer that optimizes the viscosity, cohesiveness, and macroporosity
- › The mixing liquid consists of a sodium phosphate solution that facilitates the setting time (crystallization) of the cement
- › The end product is a calcium-deficient apatite very similar to the mineral phase of bone

Physical and Chemical Properties

- › Global porosity of 70%
 - › Microporosity (<10 µm): 88%
 - › Mesoporosity (10 µm-100 µm): 2%
 - › Macroporosity (>100 µm): 10%
- › Porosity is present by the time it reaches complete hardening (24 hours after implantation)
- › Mechanical compressive strength of 24 MPa (24 hours after implantation)
- › Excellent cohesiveness, which prevents “washout” by biological fluids
- › No shrinkage during crystallization
- › Nonexothermic reaction
- › Radiopaque

Preparation

- › Mixing time (room temperature): 2 minutes
- › Injection time (room temperature): 2 minutes
- › Initial setting time (body temperature): 8 minutes
- › Complete hardening (body temperature): 24 hours

Quickset cement is intended for bony voids or defects that are not intrinsic to the stability of the bony structure. Quickset cement is intended to be placed or injected into bony voids or gaps of the skeletal system (ie, the extremities and pelvis). These defects may be surgically created osseous defects or osseous defects created from traumatic injury to the bone. The product provides bone void filler that resorbs and is replaced with bone during the healing process.

Quickset cement is available in the US as a convenience kit containing Quickset cement, a cannula, and a delivery gun.

Quickset is a trademark of Graftys, S.A.



OSferion Wedges

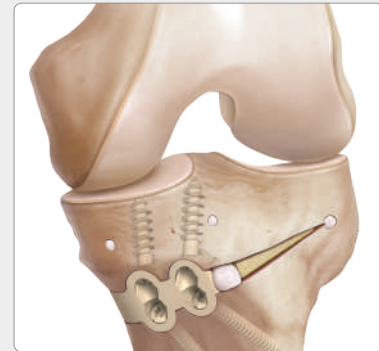

Quickset™ calcium phosphate cement and OSferion wedge used to fill the bony void created during an iBalance® HTO procedure

OSferion Osteotomy Wedge

OSferion osteotomy wedge, 7 mm × 30 mm	AR-13370-1
OSferion osteotomy wedge, 10 mm × 30 mm	AR-13370-2
OSferion osteotomy wedge, 12 mm × 35 mm	AR-13370-3
OSferion osteotomy wedge, 15 mm × 35 mm	AR-13370-4

OSferion Trapezoid

OSferion trapezoid, 8 mm × 25 mm × 7 mm × 75°	AR-13372-1
OSferion trapezoid, 9 mm × 25 mm × 7 mm × 75°	AR-13372-2
OSferion trapezoid, 10 mm × 25 mm × 7 mm × 75°	AR-13372-3

OSferion is an osteoconductive bone graft substitute and bone void filler consisting of 100% high-purity beta-tricalcium phosphate (β -TCP). OSferion wedges are intended to be used together with the distal femoral and high tibial opening wedge osteotomy plates and screws to promote healing and provide added rigidity to the repair.

- > Allows for simultaneous controlled absorption and promotion of osteogenesis
- > Microporous and macroporous structure promotes vascularization¹ and the entry of proteins into cells for bone formation²
- > The material has a compressive force of up to 20 MPa (2900 lb/in²)

OSferion Trapezoids

- > Intended to be used as a bone-patellar tendon-bone (BTB) graft harvest site bone void filler in the patella and tibia
- > OSferion naturally wicks up autologous blood and/or bone marrow
- > Can easily be customized using a rongeur or oscillating saw

References

1. Tanaka T, Kumagae Y, Saito M, et al. Bone formation and resorption in patients after implantation of beta-tricalcium phosphate blocks with 60% and 75% porosity in opening-wedge high tibial osteotomy. *J Biomed Mater Res B Appl Biomater.* 2008;86(2):453-459. doi:10.1002/jbm.b.31041
2. Dong J, Uemura T, Shirasaki Y, Tateishi T. Promotion of bone formation using highly pure porous beta-TCP combined with bone marrow-derived osteoprogenitor cells. *Biomaterials.* 2002;23(23):4493-4502.

OsteoAuger™ Bone Graft Harvesting System

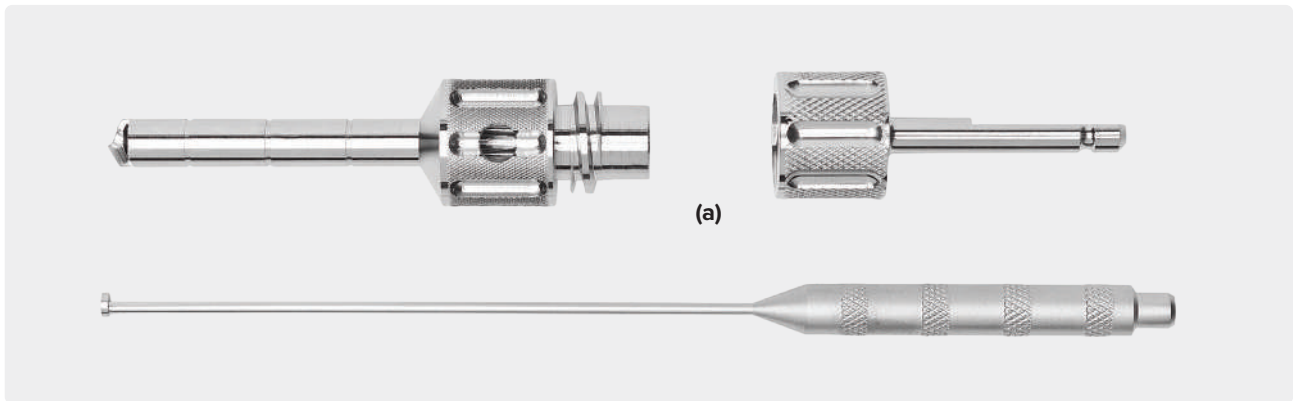

The OsteoAuger bone graft harvesting system allows for the quick and efficient recovery of autologous bone from various anatomic sites. The system morselizes and collects the bone graft for reimplantation at the repair site. The new bone graft harvesters conveniently feature an AO connection and can be easily disassembled from the reamer. A plunger is included with each harvester to assist with removing the procured autograft.

OsteoAuger bone graft harvesting system, 6 mm (a)	ABS-8000-06
OsteoAuger bone graft harvesting system, 8 mm	ABS-8000-08
OsteoAuger bone graft harvesting system, 10 mm	ABS-8000-10

Harvest Sites Include:

- > Distal tibia (6 mm, 8 mm, and 10 mm)
- > Proximal tibia (8 mm and 10 mm)
- > Iliac crest (6 mm and 8 mm)
- > Distal radius (6 mm)



GraftNet™ XL Bone Collection Device



The suction-activated GraftNet XL bone collection device is designed to collect autologous bone for a multitude of applications. When connected to an arthroscopic shaver suction, the GraftNet XL device can collect a large volume of bone graft, making access to autograft tissue as simple as Resect and Collect™.

Features and Benefits

- › Ability to collect autologous bone during a variety of surgical procedures
- › Universal adapters for easy assembly

Potential Bone Repair Applications

- › When preparing an ACL tunnel for BTB reconstruction, the GraftNet XL device can be used to recover bone that can be used to backfill the harvest site
- › When connected to a Frazier suction tip, the GraftNet XL device can collect autologous bone during spine procedures where autologous bone harvesting is desired
- › A suction wand with drip irrigation may be helpful to recover bone in a nonarthroscopic environment
- › Once recovered, mix the autograft bone with ACP or cPRP from BMA processed with the Angel® system



Collection of bone graft from ACL tunnel drilling during a BioACL™ procedure



Use of high-speed bur and Frazier suction tip to collect bone during a laminectomy

GraftNet XL autologous tissue collector

ABS-1052

GraftNet^{XL}
BONE COLLECTION DEVICE

Cartilage and Meniscus

40	GraftNet™ Autologous Tissue Collector
41	BioCartilage® Extracellular Matrix
42	Fresh Cartilage
43	Precut Fresh OCA Cores
43	Allograft OATS System
44	BioUni® OCA Instrument Set
45	BioPatella™ OATS® System
45	Talus OATS® Instrumentation Set
46	BioTalus™ OATS® Technique and Kit
47	Cartiform® Viable Osteochondral Allograft
48	Autograft OATS® 2.0 Kits
49	OATS® AlloPlug and FlexiGRAFT® Cancellous Plugs
50	Meniscal Allografts
51	Meniscal Transplantation Techniques
52	Segmental Meniscus Transplant
53	IntraOsseous BioPlasty® (IOBP®) System
54	IOBP® System (Cont.)

GraftNet™ Autologous Tissue Collector



The suction-activated GraftNet device is designed to collect autologous tissue for a multitude of applications. When connected to an arthroscopic shaver, the GraftNet device may be used to remove tissue debris, soft tissue, or cartilage from a surgical site. This recovered autologous tissue is collected in an easily accessed, sterile filtered chamber. The GraftNet autologous tissue collector makes gaining access to autograft tissue as simple as Resect and Collect™.

- › Universal adapters make for easy assembly
- › Collect autologous bone, cartilage, or soft tissue
- › Quickly access recovered tissue volume
- › Control the particulate size when using a shaver device

GraftNet autologous tissue collector	ABS-1050
Accessories	
Mixing and delivery kit, large joint	ABS-1000-L
Mixing and delivery kit, small joint	ABS-1000-S
Mixing and delivery kit, hip joint	ABS-1000-H

Cartilage

- › Autograft OATS® procedures are the benchmark when treating small, symptomatic articular cartilage lesions
- › Assemble the GraftNet tissue collector to the BoneCutter device in oscillate mode to resect and particulate an osteochondral autograft from OATS harvest sites
- › Data indicates chondrocytes maintain excellent viability (>80%) and metabolic activity¹

Reference

1. Arthrex, Inc. Data on file (APT-03989). Naples, FL; 2019.



GraftNet™
AUTOLOGOUS TISSUE COLLECTOR

BioCartilage® Extracellular Matrix

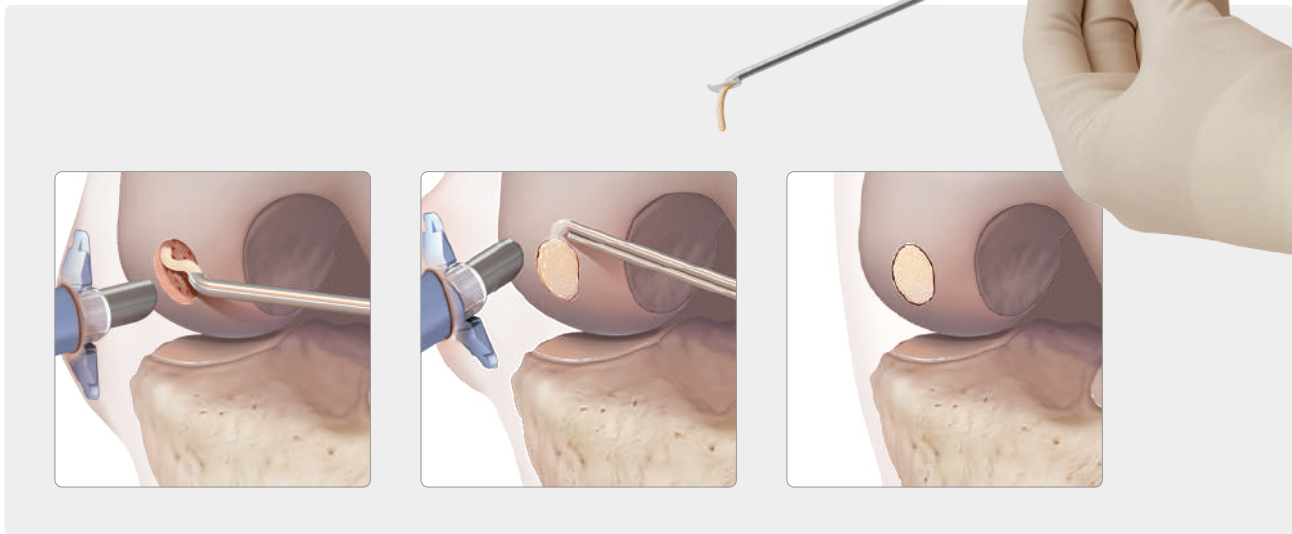

BioCartilage extracellular matrix was designed to provide a reproducible, simple, and inexpensive method to augment traditional marrow stimulation procedures. There is scientific evidence to support the premise that a dehydrated, allograft-cartilage scaffold used as an adjunct to marrow stimulation may improve the degree and quality of tissue healing within a properly prepared articular cartilage defect.^{1,2} Primate study indicates repopulation of the defect with hyaline-like cartilage at 12 weeks.³

BioCartilage extracellular matrix is an injectable cartilage-scaffold paste that can fill a cartilage defect subsequent to marrow stimulation. Difficult-to-reach focal defects can be treated open or arthroscopically with a unique delivery system.

- › BioCartilage allograft contains the extracellular matrix that is native to articular cartilage, including key components such as type II collagen (Figure 1), proteoglycans (Figure 2), and additional cartilaginous growth factors
- › The principle of BioCartilage extracellular matrix is to serve as a scaffold over an articular cartilage defect to provide a tissue network that can potentially signal autologous cellular interactions
- › Marrow elements will fill the cartilage lesion and interact with the scaffold created by BioCartilage extracellular matrix instead of the lesion being expected to create its own fibrin scaffold, as typically anticipated from a marrow stimulation procedure

BioCartilage extracellular matrix, 0.75 cc	ABS-1007-BC
BioCartilage extracellular matrix, 1 cc	ABS-1010-BC
Mixing and delivery kit, large joint	ABS-1000-L
Mixing and delivery kit, small joint	ABS-1000-S
Mixing and delivery kit, hip kit	ABS-1000-H
Accessories	
PowerPick™ XL microfracture instrument, 45°, 6 mm depth	AR-8150PX-45

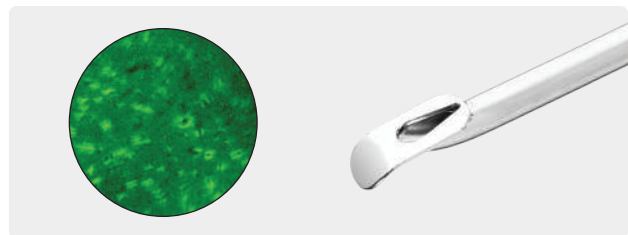

Figure 1. Immunohistochemistry staining for type II collagen.^a



Figure 2. Toluidine blue stain highlighting proteoglycan content.^a

^aThe tissue was stained after the dehydration step.

References

1. Cheng NC, Estes BT, Awad HA, Guilak F. Chondrogenic differentiation of adipose-derived adult stem cells by a porous scaffold derived from native articular cartilage extracellular matrix. *Tissue Eng Part A*. 2009;15(2):231-241. doi:10.1089/ten.tea.2008.0253
2. Chadha N, Dang A, Sampson E, et al. Porous cartilage-derived matrix scaffolds for repair of articular cartilage defects. Poster presented at: Orthopaedic Research Society Annual Meeting; February 4-7, 2012; San Francisco, CA.
3. Malinin T, Temple HT, Carpenter EM. Induction of regeneration of articular cartilage defects by freeze-dried particulate cartilage allografts. Poster presented at: International Cartilage & Joint Preservation Society Annual Meeting; 2009; Miami, FL.

Fresh Cartilage

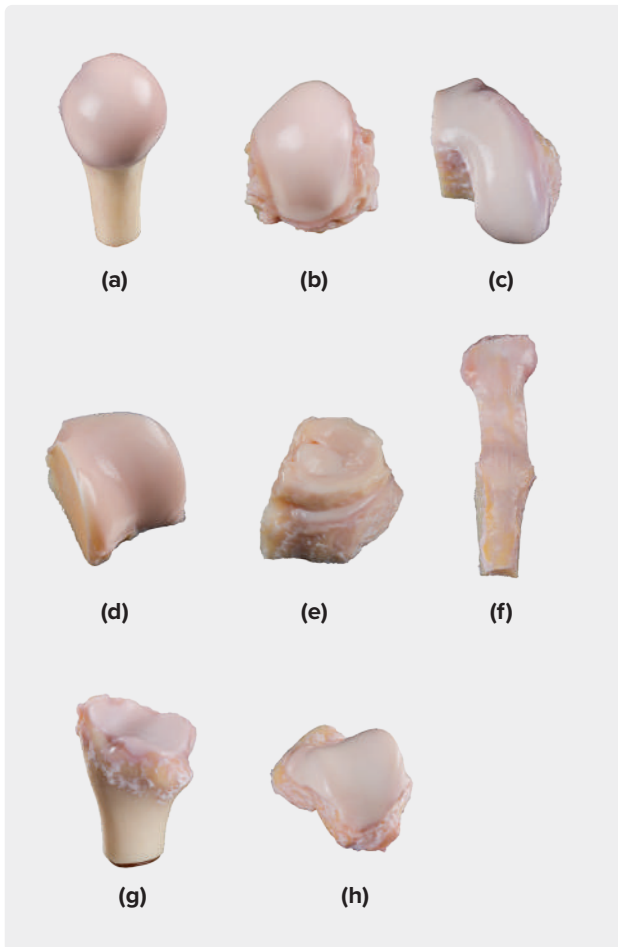

Arthrex has a long-standing partnership with leading tissue banks to provide fresh osteochondral allografts (OCAs) for use in joint restoration procedures. Fresh OCAs allow the surgeon to transplant mature hyaline cartilage with viable chondrocytes and subchondral bone in a single procedure.

	JRF Ortho Part No.	LifeNet Health Part No.
Upper extremity/shoulder		
Humeral head, right (a)	41247001	HHR80
Humeral head, left	41247002	HHL80
Elbow		
Distal humerus, right	44647001	
Distal humerus, left	44647002	
Proximal ulna, right	45847001	
Proximal ulna, left	45847002	
Lower extremity/hip		
Femoral head, right	41847001	FHR80
Femoral head, left	41847002	FHL80

	JRF Ortho Part No.	LifeNet Health Part No.
Knee		
Medial partial hemi-condyle, right	43647001	PCC80
Medial partial hemi-condyle, left	43647002	PCB80
Lateral partial hemi-condyle, right	43747001	PCD80
Lateral partial hemi-condyle, left (b)	43747002	PCA80
Medial femoral hemi-condyle, right	32247001	FCC80
Medial femoral hemi-condyle, left	32247002	FCB80
Lateral femoral hemi-condyle, right (c)	32147001	FCD80
Lateral femoral hemi-condyle, left	32147002	FCA80
Whole femoral condyle, right	33547001	FCR80
Whole femoral condyle, left	33547002	FCL80
Femoral trochlea, right (d)	43547001	FTR80
Femoral trochlea, left	43547002	FTL80
BiCompartment, right lateral and trochlea	43747003	FTD80
BiCompartment, left lateral and trochlea	43747004	FTA80
BiCompartment, right medial and trochlea	43647003	FTC80
BiCompartment, left medial and trochlea	43647004	FTB80
Medial hemi-tibial plateau w/ meniscus, right (e)	44947001	
Medial hemi-tibial plateau w/ meniscus, left	44947002	
Lateral hemi-tibial plateau w/ meniscus, right	45047001	
Lateral hemi-tibial plateau w/ meniscus, left	45047002	
Whole tibial plateau w/ meniscus, right	32447001	TFR80
Whole tibial plateau w/ meniscus, left	32447002	TFL80
Patella bone w/ attachment, right (f)	33647001	PAR80
Patella bone w/ attachment, left	33647002	PAL80
Foot and ankle		
Distal tibia, right (g)	32747001	TDR80
Distal tibia, left	32747002	TDL80
Talus, right (h)	32647001	ATR80
Talus, left	32647002	ATL80
Proximal metatarsal bone, right	44747001	
Proximal metatarsal bone, left	44747002	
Distal metatarsal bone, right	44847001	
Distal metatarsal bone, left	44847002	

Precut Fresh OCA Cores

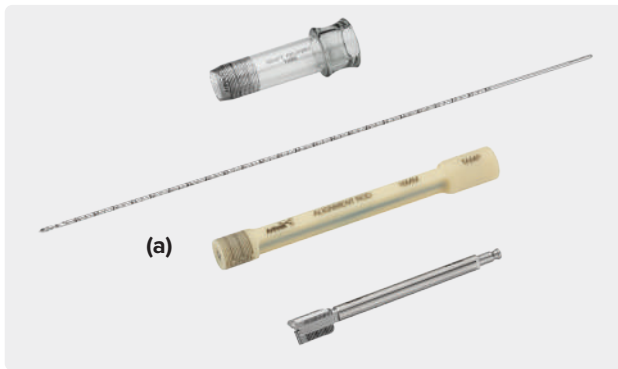

Precut OCA cores provide a biologic and structural repair for full-thickness osteochondral lesions. OCA cores provide the optimal architecture, biomechanical support, and viable hyaline cartilage to support the repair during healing. The availability of fresh OCA cores now provides surgeons with a convenient new tool in their cartilage treatment algorithm without the challenge of harvesting sufficient and suitable autologous donor cartilage.

The 16 mm allograft OATS® disposable kit contains an assortment of single-use instruments designed to prepare a 16 mm-diameter socket through cartilage and subchondral bone. Paired with a precut, fresh 16 mm osteochondral allograft from JRF Ortho or LifeNet Health, these instruments allow for quick preparation and implantation of viable and mature hyaline cartilage and bone.

	Arthrex Item Number	JRF Ortho Item Number	LNH Part Number
Precut osteochondral core, fresh, 10 mm		45647010	RFP10
Precut osteochondral core, fresh, 12 mm		45647012	
Precut osteochondral core, fresh, 16 mm		45647016	RFP16
Single-use OATS set, 16 mm (a)	ABS-1981-16S		

Allograft OATS System

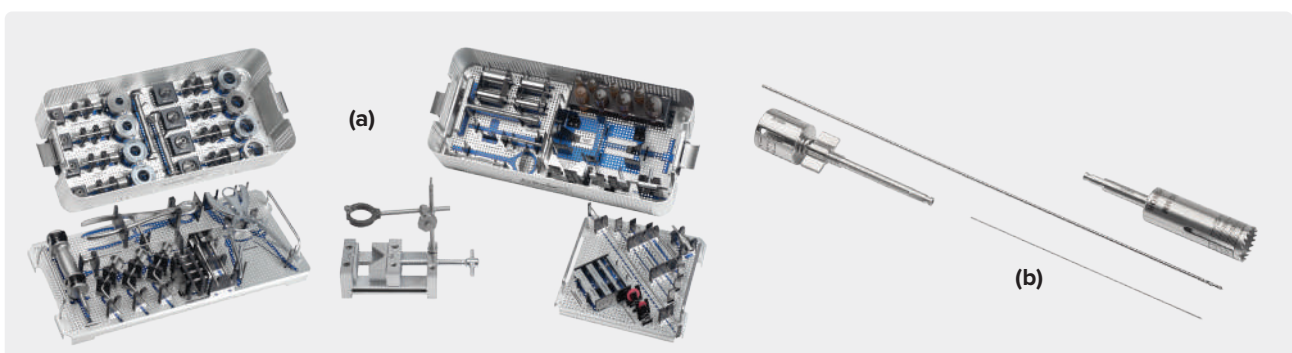

The allograft OATS system can be used for intraoperative harvesting of 15 mm to 35 mm diameter cores from fresh allografts.

There are few treatment options for patients with large symptomatic lesions of osteoarticular surfaces. Using allografts for osteoarticular resurfacing gives surgeons the ability to match the contour and cartilage morphology of the recipient site, while avoiding multiple surgical sites and the possible donor site morbidity associated with recovering an autograft from the knee. Fresh grafts are

stored in a proprietary storage media and maintained at 4 °C. These grafts should be implanted as soon as possible to maintain the highest levels of viable chondrocytes.

Allograft OATS instrument set (a)	RAR-4058MS
Allograft OATS disposable kit (b) Sizes: 15, 18, 20, 22.5, 25, 27.5, 30, 35 mm	ABS-4057D-15 to -35

The allograft OATS instrumentation set is made available when working with your Arthrex Technology Consultant to secure a fresh osteochondral allograft through an Arthrex tissue partner.

BioUni® OCA Instrument Set

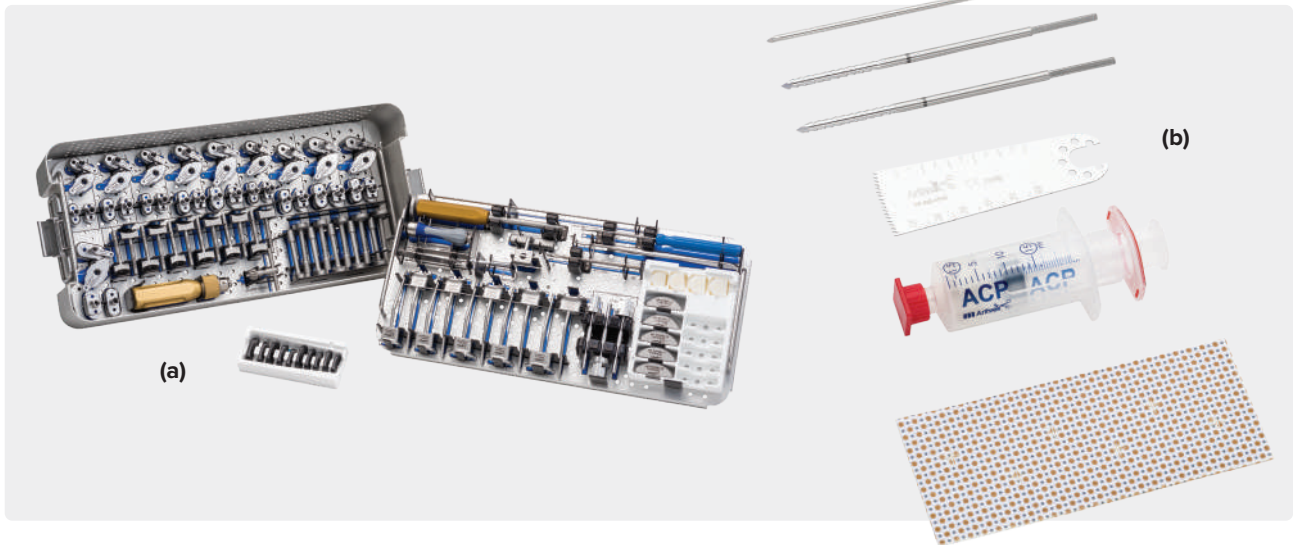

The BioUni OCA instrument set is the new standard for restoration of the articular surface when presented with elongated cartilage defects in the medial femoral condyle. Through a series of precisely designed cutting instruments, surgeons can replace damaged cartilage with a single, elliptical piece of viable hyaline cartilage.

The BioUni instruments address many of the challenges and risks associated with the recovery and implantation of multiple small and large cartilage cores. Overlapping multiple cores adds complexity of curve matching, fit, and surgical time for each procedure. The BioUni instruments were designed to match the natural curvature of the femoral condyle to remove those complexities. Multiple sizes allow flexibility for the surgeon to adjust the width and length of the cartilage defect and to ensure proper restoration of the articular surface with a single cartilage piece.



BioUni OCA instrument set (a)	RAR-4058MS
BioUni disposable kit (b)	ABS-4080D
BioUni cutting kits Sizes: S14, S17, M14, M17, M20, L14, L17, L20, X17, X20	ABS-4080D-S14 to -X20
Accessories	
PowerPick™ microfracture instrument, 45°, 6 mm depth	AR-8150PX-45
PowerPick microfracture instrument, 30°, 4 mm depth	AR-8150PP-30
PowerPick microfracture instrument, 45°, 6 mm depth (5 pk)	AR-8150PP-45
Autologous conditioned plasma (ACP)	ABS-10010S
AlloSync™ gel, 1 cc	ABS-2002-01
AlloSync gel, 5 cc	ABS-2002-05

BioPatella™ OATS® System

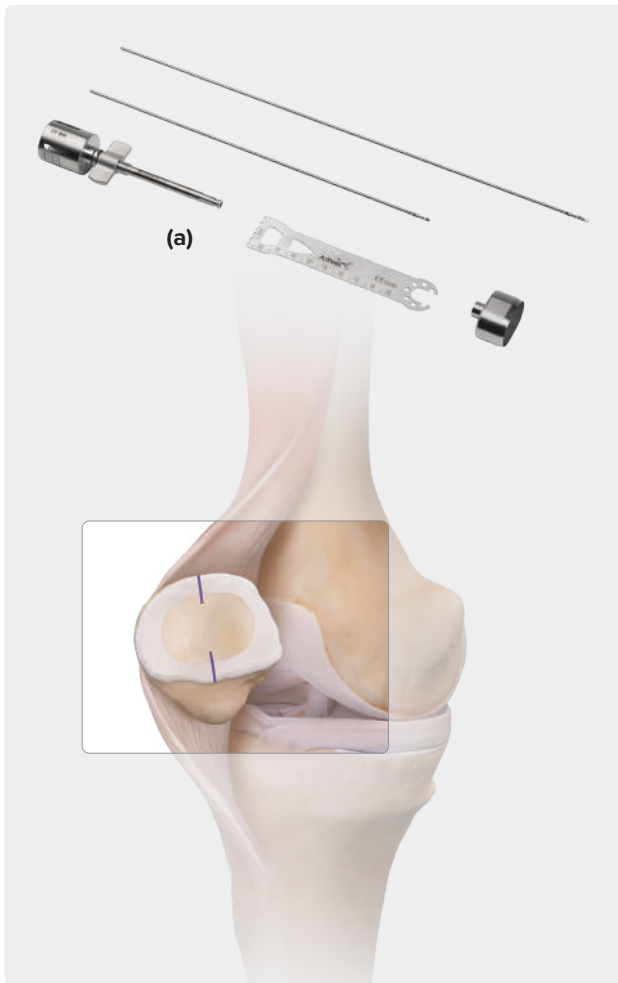

The BioPatella instrument set is the new standard for restoration of the articular surface of the patella when presented with oblong cartilage defects involving a significant amount of the patellar articular surface. Through a series of precisely designed cutting instruments, surgeons can replace damaged cartilage with a single, elliptical piece of viable, hyaline cartilage.

The BioPatella instruments address many of the challenges and risks associated with the recovery and implantation of standard smaller cylindrical cartilage cores. Positioning a standard round graft often does not suffice to adequately resurface the entirety of the injured articular surface. The BioPatella instruments were designed to match the natural curvature of the patella to resurface the entire functional articular surface. Multiple sizes allow flexibility for the surgeon to adjust the width and length of the cartilage defect and to ensure proper restoration of the articular surface with a single cartilage piece.

BioPatella instrument set, small, 20 mm × 30 mm (a)	ABS-4085D-S
BioPatella instrument set, medium, 25 mm × 35 mm	ABS-4085D-M
BioPatella instrument set, large, 27.5 mm × 37.5 mm	ABS-4085D-L

BioPatella instrumentation includes sizes small, medium, and large, each with an accompanying disposable kit.

Technique described by Thomas M. DeBerardino, MD (San Antonio, TX).

Talus OATS® Instrumentation Set

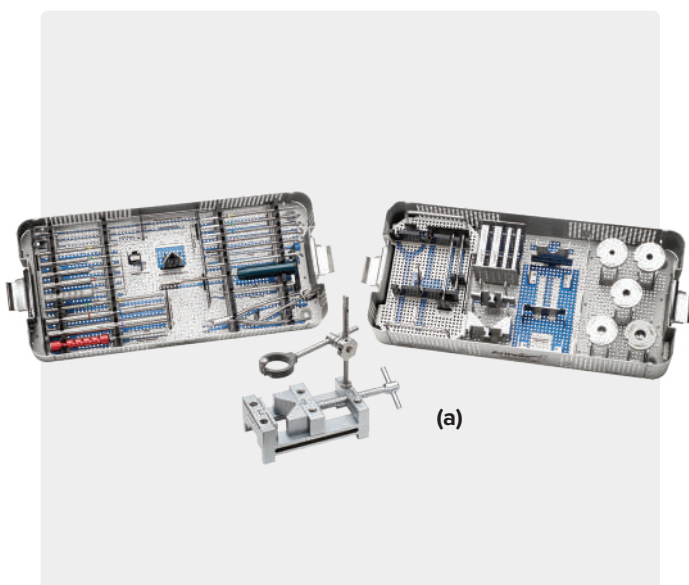

The Talus OATS instrumentation set facilitates harvesting of small-diameter (6 mm to 15 mm) osteochondral/hyaline cartilage cylinders from allograft bone. The core is made by placing the fresh talus into the workstation and harvesting it with the donor harvester. A recipient socket is created 0.5 mm undersized with the appropriately sized recipient harvester. The exact depth of the allograft, to match the socket, is obtained using the depth measurement guide and the allograft is trimmed to the same depth and obliquity. Dilation of the socket results in a line-to-line fit once the donor allograft is inserted into the recipient socket. Final seating of the allograft is achieved with an oversized tamp, resulting in a perfectly flush, press-fit graft that does not require fixation implants.

Talus allograft OATS workstation and instrumentation set, 6 mm, 8 mm, 10 mm, 12 mm, 15 mm (a)	RAR-8901S
---	-----------

BioTalus™ OATS® Technique and Kit

The BioTalus technique enables the recovery of a large, wedge-shaped allograft to replace large-oblong defects of the talus with subchondral bone involvement. The BioTalus cutting guide, sizing accessory, and osteotome are provided in the Talus OATS tray. The BioTalus Disposable Kit includes a guidewire, breakaway pins, and malleable tissue retractor to facilitate a precise and reproducible technique.

With an anterior approach, the BioTalus technique addresses large osteochondral defects of the talus and eliminates the need for malleolar osteotomies. Expanding the allograft OATS technique with BioTalus instrumentation advances the Arthrex cartilage repair algorithm for the talus.

BioTalus disposable kit (a)	ABS-4090D
Talus OATS instrumentation (b)	RAR-8901S

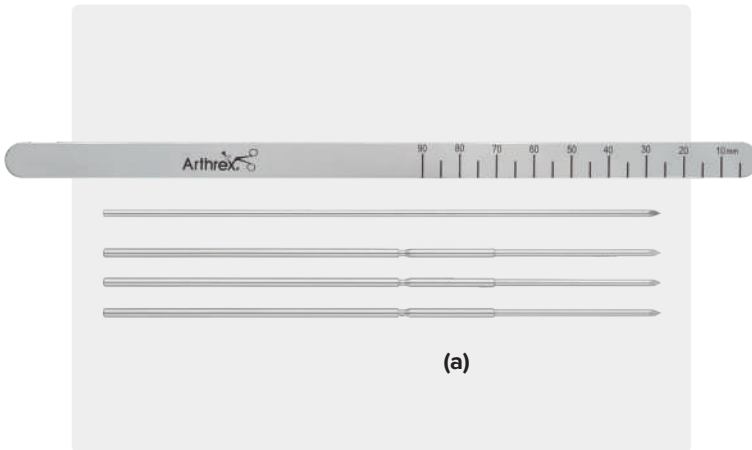
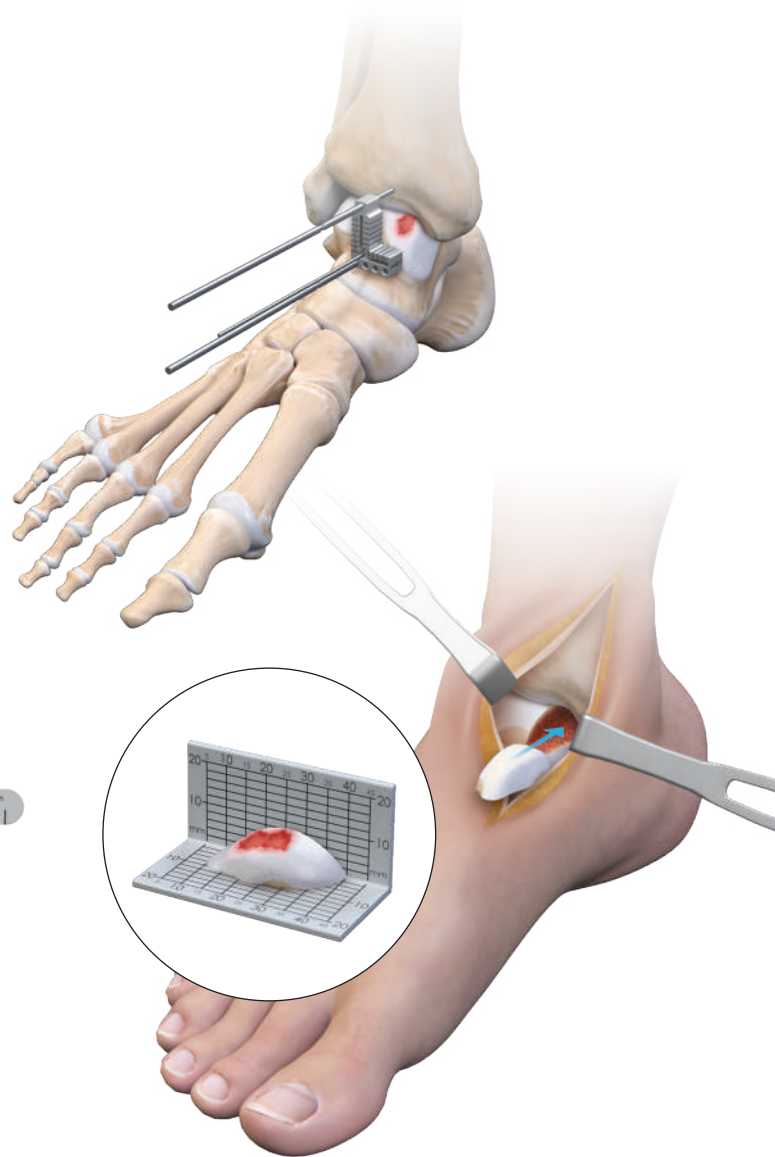

BioTalus Disposable Kit

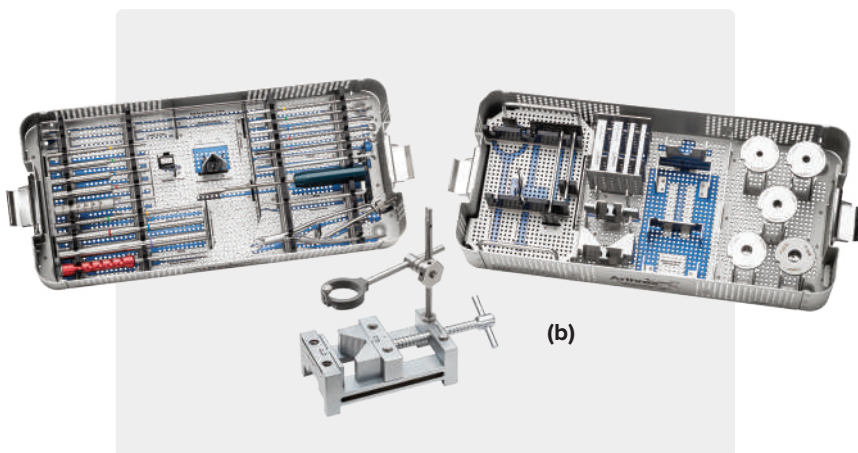

Talus OATS Instrumentation

Cartiform® Viable Osteochondral Allograft

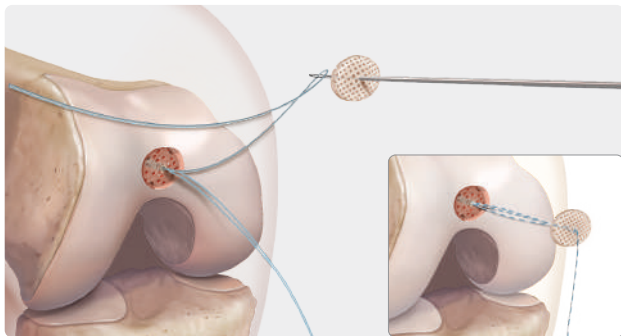
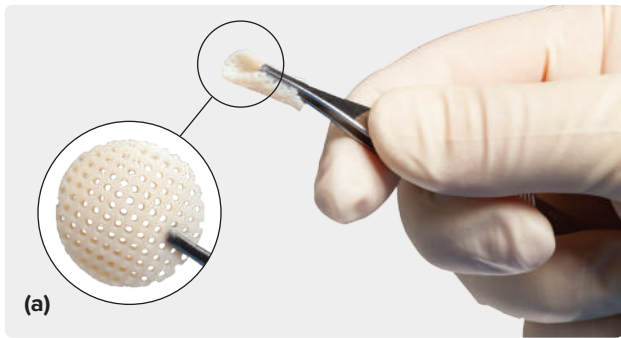

Fixation of Cartiform viable osteochondral allograft in the trochlea is achieved using the Knotless SutureTak® percutaneous insertion kits.

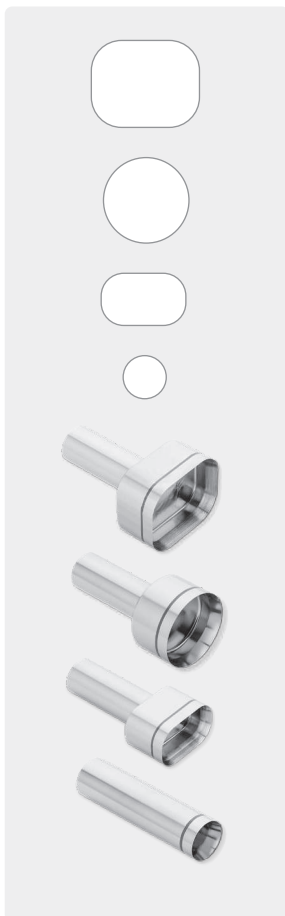

Cartiform viable osteochondral allograft may be trimmed to fit the articular cartilage lesion. Templates and scorers are available to aid in preparation of the graft and recipient site.

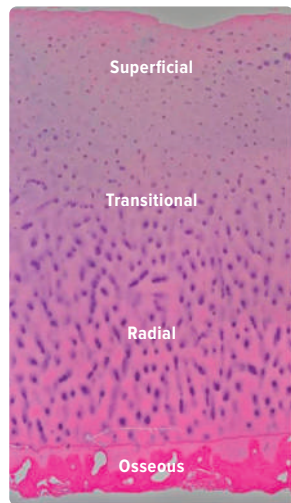

Figure 1. Structural organization of Cartiform allograft. Cartiform viable osteochondral allograft preserves the microstructure of 3 distinct cartilage zones (superficial, transitional, and radial) and an osseous layer as evident on histological staining (H&E).

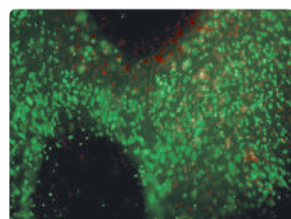

Figure 2. Live (green) and dead (red) cell staining of Cartiform unit post-thaw after 2.7 years storage at -80 °C, 70% cell viability.

Cartiform allograft is a cryopreserved osteochondral allograft composed of viable chondrocytes, chondrogenic growth factors, and extracellular matrix proteins. While maintaining an intact cartilage structure (Figure 1), the bony portion of the osteochondral allograft is minimal and the graft is porated to offer unique handling characteristics and simple fixation techniques.

Cartiform viable osteochondral allograft is recovered with minimal bone and porated for a variety of reasons:

- › The minimal bone and pores impart flexibility to the allograft
- › The pores increase the surface area and allow for the proprietary cryopreservative solution to preserve chondrocyte viability
- › The pores facilitate enhanced growth factor release from Cartiform viable osteochondral allograft

Cartiform viable osteochondral allograft combines the safety and success of traditional fresh stored osteochondral allografts with ease of use, as the graft is trimmable and flexible to match any lesion size and contour.

Stored in a proprietary cryopreservative solution, Cartiform viable osteochondral allograft is readily available and is stored at -80 ± 5 °C. (Figure 2).¹

Cartiform viable osteochondral allograft, 10 mm disc	ABS-1101-10
Cartiform viable osteochondral allograft, 12 mm × 19 mm	ABS-1102-19
Cartiform viable osteochondral allograft, 20 mm disc (a)	ABS-1101-20
Cartiform viable osteochondral allograft, 20 mm × 25 mm	ABS-1102-25
Cartiform templates	ABS-1100-T
Cartiform scorer, 10 mm	ABS-1101-10S
Cartiform scorer, 20 mm	ABS-1101-20S
Cartiform scorer, 12 mm × 19 mm	ABS-1102-19S
Cartiform scorer, 12 mm × 25 mm	ABS-1102-25S

Cartiform is a registered trademark of Osiris Therapeutics, Inc.

Reference

1. Arthrex, Inc. and Osiris Therapeutics, Inc. LA1-00007-EN_A. Naples, FL; 2015.

Autograft OATS® 2.0 Kits



The single-use OATS (Osteochondral Autograft Transfer System) 2.0 kit facilitates harvesting of 6, 8, 10, or 12 mm osteochondral cartilage cylinders from a donor site, superior and lateral to the notch or above the sulcus terminalis, for reimplantation at the damaged cartilage site.

The completely disposable, size-specific system includes a recipient reamer, donor harvester, alignment rod, tamp, graft delivery tube, core extruder for controlled push-in core insertion, and optional graft driver.

The OATS 2.0 set includes depth-stop features to control the recipient site and donor plug to either 8 mm or 13 mm lengths.

Single Use OATS 2.0 Set

Single-use OATS set, 6 mm	ABS-8981-06S
Single-use OATS set, 8 mm	ABS-8981-08S
Single-use OATS set, 10 mm (a)	ABS-8981-10S
Single-use OATS set, 12 mm	ABS-8981-12S

OATS® AlloPlug and FlexiGRAFT® Cancellous Plugs

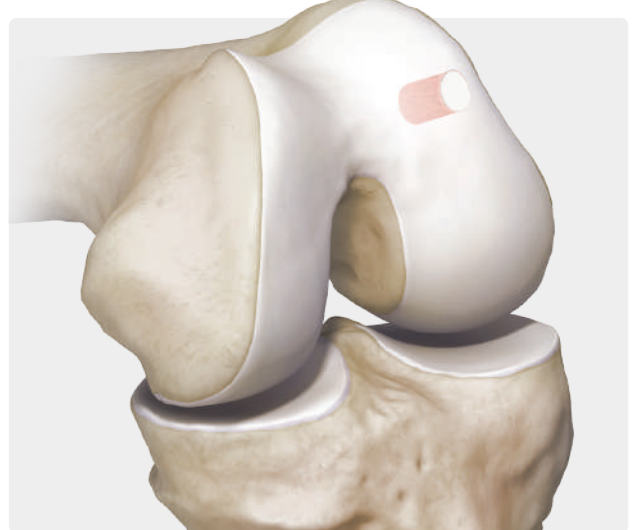
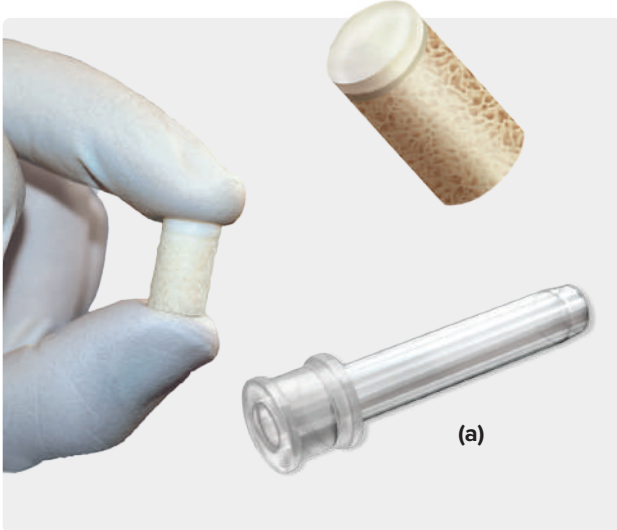

Surgeons concerned about possible donor site morbidity caused by leaving the donor site sockets open may now use these specially designed cancellous backfill plugs to fill the donor site and promote natural bone healing for a complete biologic repair.

AlloPlugs are processed from the articular surface, resulting in a multiphasic plug composed of a dense cancellous layer, a cortical layer, and a cartilage layer. These plugs come in a range of sizes from 7 mm to 11 mm in diameter and 16 mm in length.

FlexiGRAFT cancellous plugs are comprised of 100% human cancellous bone for use in backfill and bone void procedures. These plugs are provided sterile via the Allowash XG® process and stored in Preservon®, a proprietary glycerol-based preservation technology that allows allografts to be stored in a fully hydrated state at ambient temperature for up to 5 years. Preservon preservation technology eliminates the lengthy thawing and rehydrating times and does not require freezer storage. These plugs are available in sizes from 6 mm to 11 mm in diameter (1 mm increments) and 16 mm in length.

When selecting a graft for backfill applications, the implant should be sized 1 mm larger than the harvested OATS core. For example, in a case where an 8 mm OATS harvester is used, a 9 mm allograft plug is used to provide a line-to-line fit in the donor site.

An additional allograft plug delivery sleeve may be ordered to facilitate implantation of the plug.

	LifeNet Health Item Number
AlloPlug frozen backfill plug w/ cartilage, 7 mm	FCPD7
AlloPlug frozen backfill plug w/ cartilage, 8 mm	FCPD8
AlloPlug frozen backfill plug w/ cartilage, 9 mm	FCPD9
AlloPlug frozen backfill plug w/ cartilage, 10 mm	FCPD10
AlloPlug frozen backfill plug w/ cartilage, 11 mm	FCPD11

	LifeNet Health Item Number
FlexiGRAFT cancellous plug, 6 mm	PCPD6
FlexiGRAFT cancellous plug, 7 mm	PCPD7
FlexiGRAFT cancellous plug, 8 mm	PCPD8
FlexiGRAFT cancellous plug, 9 mm	PCPD9
FlexiGRAFT cancellous plug, 10 mm	PCPD10
FlexiGRAFT cancellous plug, 11 mm	PCPD11

Allograft plug delivery sleeve, 7 mm (a)	AR-1981BI-07
Allograft plug delivery sleeve, 9 mm	AR-1981BI-09
Allograft plug delivery sleeve, 11 mm	AR-1981BI-11

Meniscal Allografts



Better understanding of the biomechanical consequences of total and partial meniscectomy has led surgeons to explore methods of meniscus preservation. However, in many cases, the damage is far too extensive to preserve the meniscus and few options exist for these patients.

Meniscal allografts have proven to be effective in improving function and reducing pain for selected patients with a meniscus-deficient knee.¹ Arthrex can provide medial and lateral meniscal allografts that come with sufficient bone block to perform various anchorage procedures, including double-bone plug, keyhole, and dovetail techniques.

Meniscal allografts are most commonly used in symptomatic patients with prior meniscectomy and persistent pain. Patients should have normal alignment and should not have articular damage greater than grade III. Serious articular disease, osteophyte formation, or flattening of the femoral condyle are common contraindications for meniscal transplant.

	JRF Ortho Part No.	LifeNet Health Part No.
Lateral meniscus, right	28325001	FMN RL
Lateral meniscus, left	28325002	FMN LL
Medial meniscus, right	28225001	FMN RM
Medial meniscus, left	28225002	FMN LM

Meniscal allograft tissue is also available upon request for nonknee transplantation, such as carpometacarpal or metatarsophalangeal joint procedures.

Reference

1. Crook TB, Ardolino A, Williams LA, Barlow IW. Meniscal allograft transplantation: a review of the current literature. *Ann R Coll Surg Engl.* 2009;91(5):361-365. doi:10.1308/003588409X428559

Meniscal Transplantation Techniques

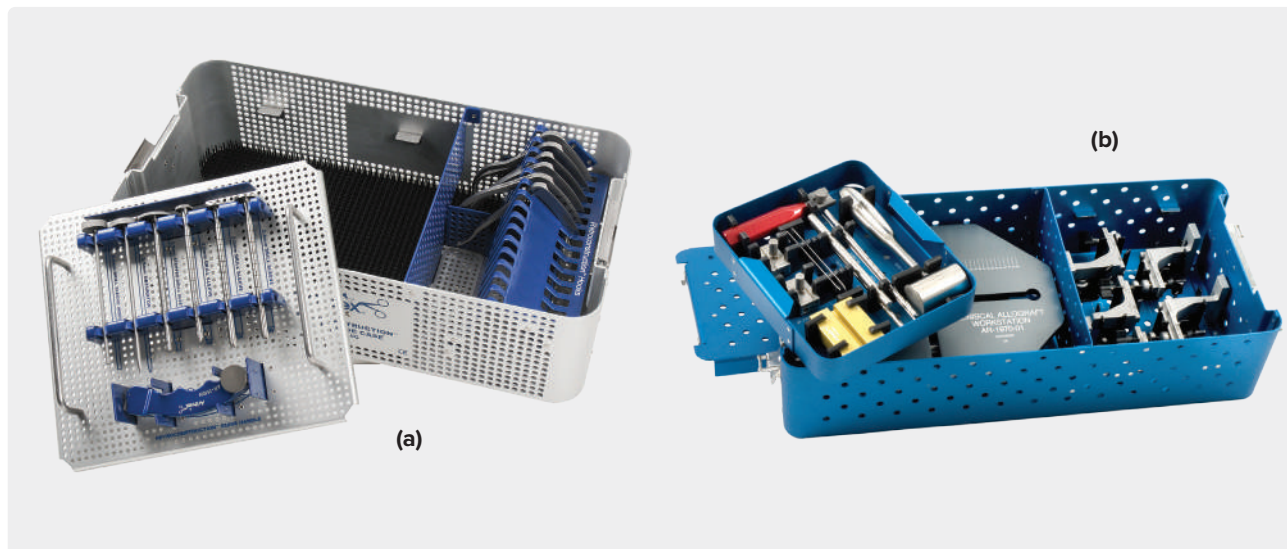

Meniscal allografts have proven to be a viable alternative in reducing the sequelae of arthritis that can result from meniscal excision.¹ The surgical technique for meniscal allograft transplantation of the knee continues to evolve.

Simplified preparation of the graft and recipient tibia, which allow the transplant to be positioned anatomically and anchored with reliable fixation, is the ultimate goal of the procedure.

Double–Bone-Plug Meniscal Reconstruction

The double–bone–plug technique for meniscal allograft reconstruction provides a method for implanting the meniscal allograft with rigid fixation at the horn attachments. It has been demonstrated that bony fixation at the attachment site allows for the maintenance of functional hoop stress by the meniscal allograft.¹

Dovetail Meniscal Reconstruction

The dovetail technique simplifies graft preparation with a time-saving series of cuts preparing the bone component of the graft to sit securely in the recipient semitrapezoidal slot created in the tibia. A matching semitrapezoidal recipient slot created in the tibia with a series of step drills, rasps, and dilators matches the bone block preparation.

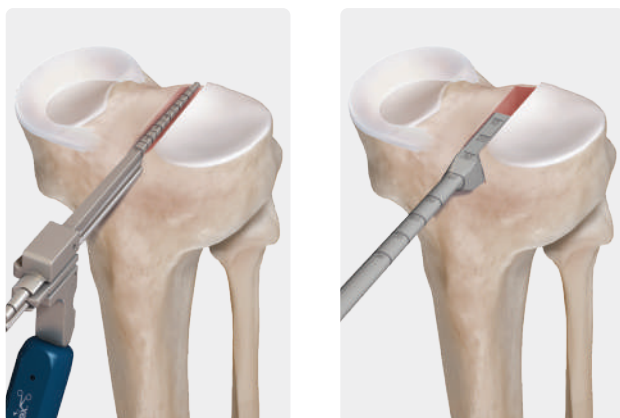

A “box” technique that requires interference screw fixation is also available.

RetroConstruction™ drill guide set (a)	AR-1510S
Dovetail meniscal allograft instrumentation set (b)	AR-1970S

The dovetail meniscal allograft instrumentation set is made available when working with your Arthrex Technology Consultant to secure a meniscus allograft.

Reference

1. Chen MI, Branch TP, Hutton WC. Is it important to secure the horns during lateral meniscal transplantation? A cadaveric study. *Arthroscopy*. 1996;12(2):174-181.

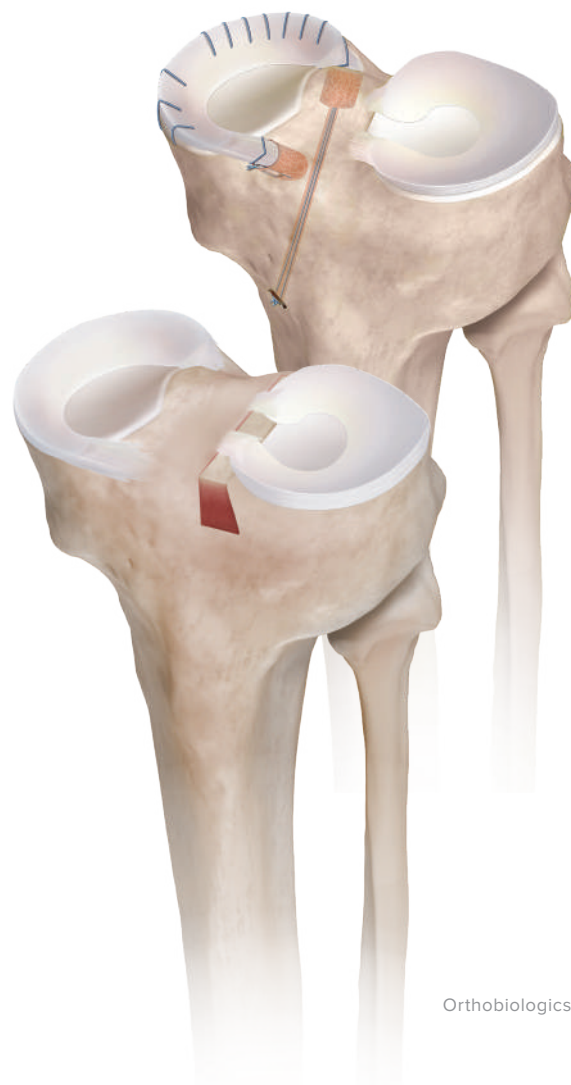

Segmental Meniscus Transplant

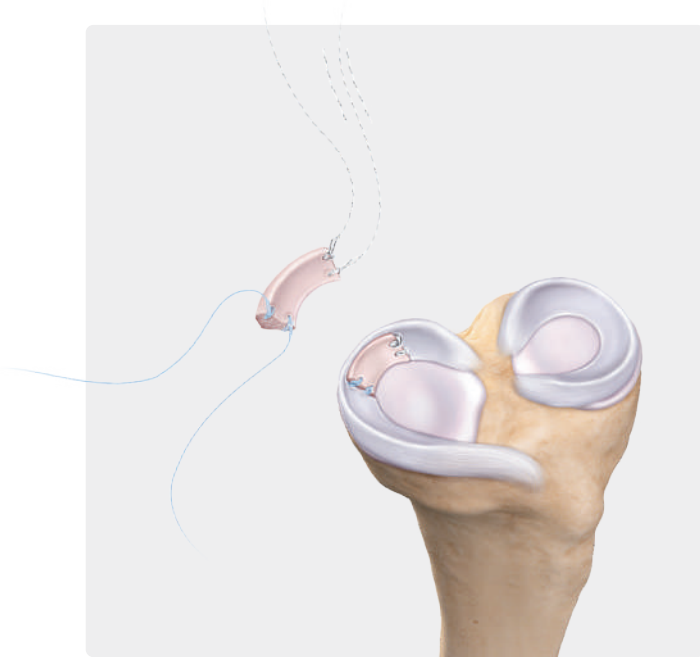

	JRF Ortho Part No.	LifeNet Health Part No.
Lateral meniscus, right	28325001	FMN RL
Lateral meniscus, left	28325002	FMN LL
Medial meniscus, right	28225001	FMN RM
Medial meniscus, left	28225002	FMN LM

Features and Benefits¹

- › Intact portions of the meniscus are maintained
- › Restoration of joint contact pressure when the segmental defect is restored
- › Preserved mechanoreceptors within the native meniscus may improve proprioception and joint homeostasis
- › Segmental meniscus transplant is firmly secured with suture anchors at the junction of allograft-to-native meniscus

ZoneNavigator™ system handle	AR-7900
ZoneNavigator system anterior cannula	AR-7905
ZoneNavigator system middle cannula, left posterior	AR-7910L
ZoneNavigator system middle cannula, right posterior	AR-7910R
Knee Scorpion™ suture passer	AR-12990
FiberStitch™ implant, curved	AR-4570
FiberStitch implant, 24° curve	AR-4570-24
FiberStitch implant, reverse curve	AR-4570R
FiberStitch implant, straight	AR-4570S

Reference

1. Seiter MN, Haber DB, Ruzbarsky JJ, Arner JW, Peebles AM, Provencher MT. Segmental meniscus allograft transplantation. *Arthrosc Tech.* 2021;10(3):e697-e703. doi:10.1016/j.eats.2020.10.059

Segmental meniscus is a meniscus preservation option for prior failed repairs, partially menisectomized and/or nonrepairable meniscus with intact roots. The allograft meniscus can be appropriately sized to the patient's defect area to maintain the intact portions of the meniscus, such as the meniscal roots.

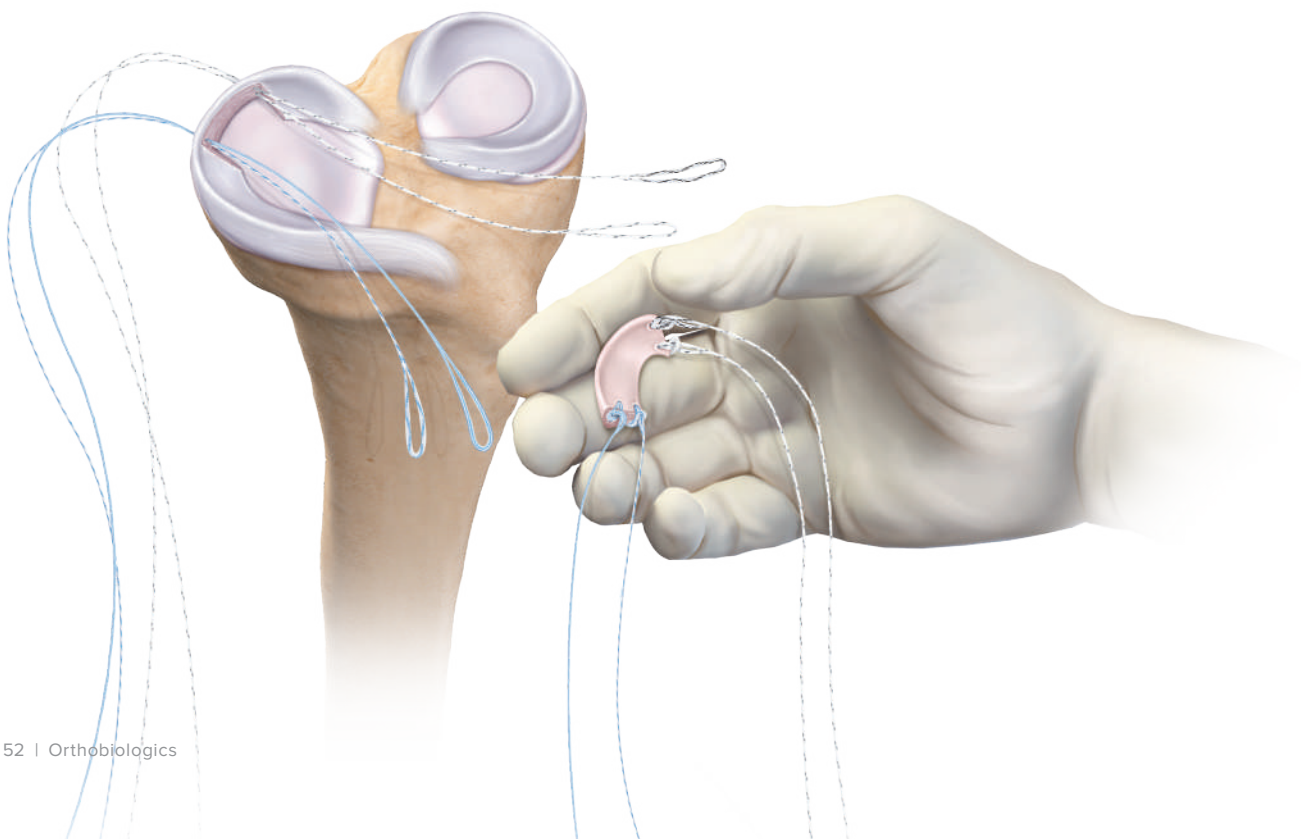

IntraOsseous BioPlasty® (IOBP®) System

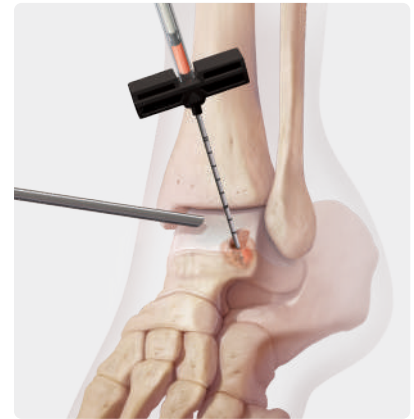
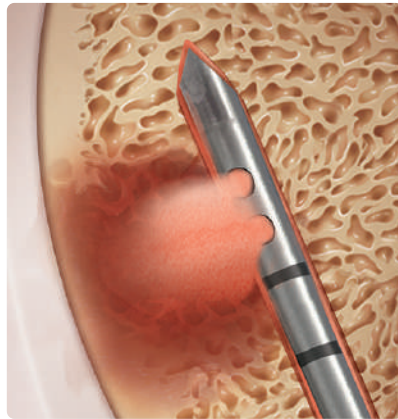
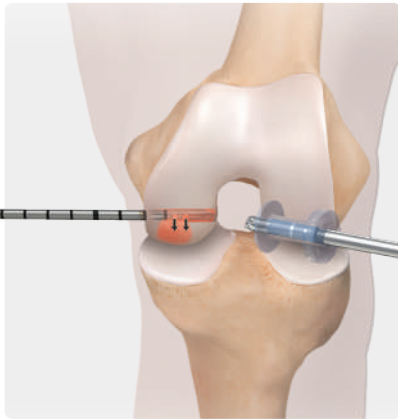

The IntraOsseous BioPlasty (IOBP) surgical technique is intended for the treatment of bone pathologies resulting from acute or chronic injury, including bone marrow lesions (BMLs) associated with insufficiency fractures, persistent bone bruises, osteoarthritis, and early stages of avascular necrosis. Arthrex offers a biologic option for the treatment of these pathologies by performing a core decompression of the lesion and a direct application of cPRP from BMA using the Angel® cPRP and bone marrow processing system.

A prospective clinical trial looked at 20 patients with symptomatic BMLs that had failed conservative treatment and were indicated for the IOBP procedure. The authors mixed AlloSync™ Pure DBM with cPRP from BMA using the Angel system to deliver the mixture to the BML. The authors concluded that biologic treatment of BML is an “effective adjunct to arthroscopy that provides short-term pain relief for BMLs associated with degenerative conditions of the knee. This procedure is associated with clinically significant improvements in knee pain and function over a short-term follow-up.”¹

Additionally, research has shown the positive clinical outcomes of treating BMLs and persistent bone fractures, or nonunions, with bone marrow concentrate.² Clinical outcomes from another study indicate pain and function improve following intraosseous delivery of a biologic into BMLs associated with osteoarthritis.³

The IOBP procedure is the biologic treatment of BMLs with techniques that encourage physiologic bone remodeling and repair.

Note: AlloSync Pure DBM or AlloSync gel, provided separately, may be mixed with the autologous blood solution.

Concentration of Stem Cells in Bone Graft Affect Outcome⁴

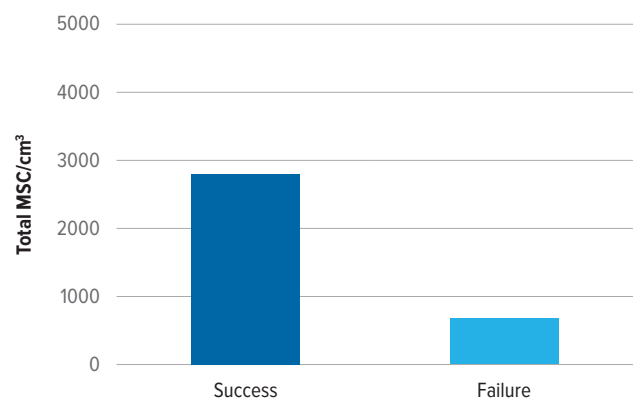

Clinical Outcomes When Treating Osteoarthritis³

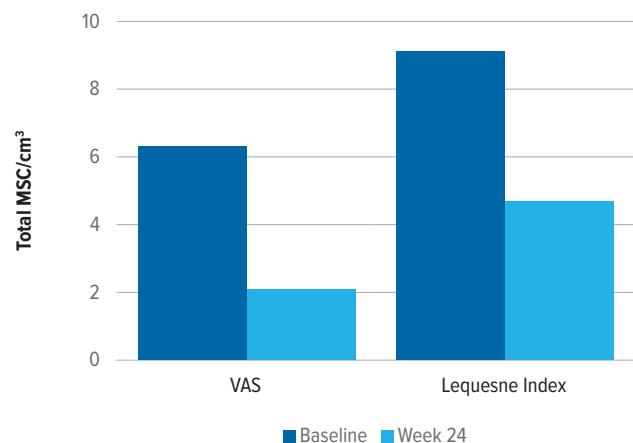

References

1. Kasik C, Martinkovich S, Mosier B, et al. Short-term outcomes for the biologic treatment of bone marrow edema of the knee using bone marrow aspirate concentrate and injectable demineralized bone matrix. *Arthrosc Sports Med Rehabil.* 2019;1(1):e7-e14. doi.org/10.1016/j.asmr.2019.07.001
2. Chen MI, Branch TP, Hutton WC. Is it important to secure the horns during lateral meniscal transplantation? A cadaveric study. *Arthroscopy.* 1996;12(2):174-181.
3. Sánchez M, Delgado D, Sánchez P, et al. Combination of intra-articular and intraosseous injections of platelet rich plasma for severe knee osteoarthritis: a pilot study. *Biomed Res Int.* 2016;4868613. doi:10.1155/2016/4868613
4. Hernigou P, Poignard A, Beaujean F, Rouard H. Percutaneous autologous bone-marrow grafting for nonunions. Influence of the number and concentration of progenitor cells. *J Bone Joint Surg Am.* 2005;87(7):1430-1437. doi:10.2106/JBJS.D.02215

IOBP® System (Cont.)

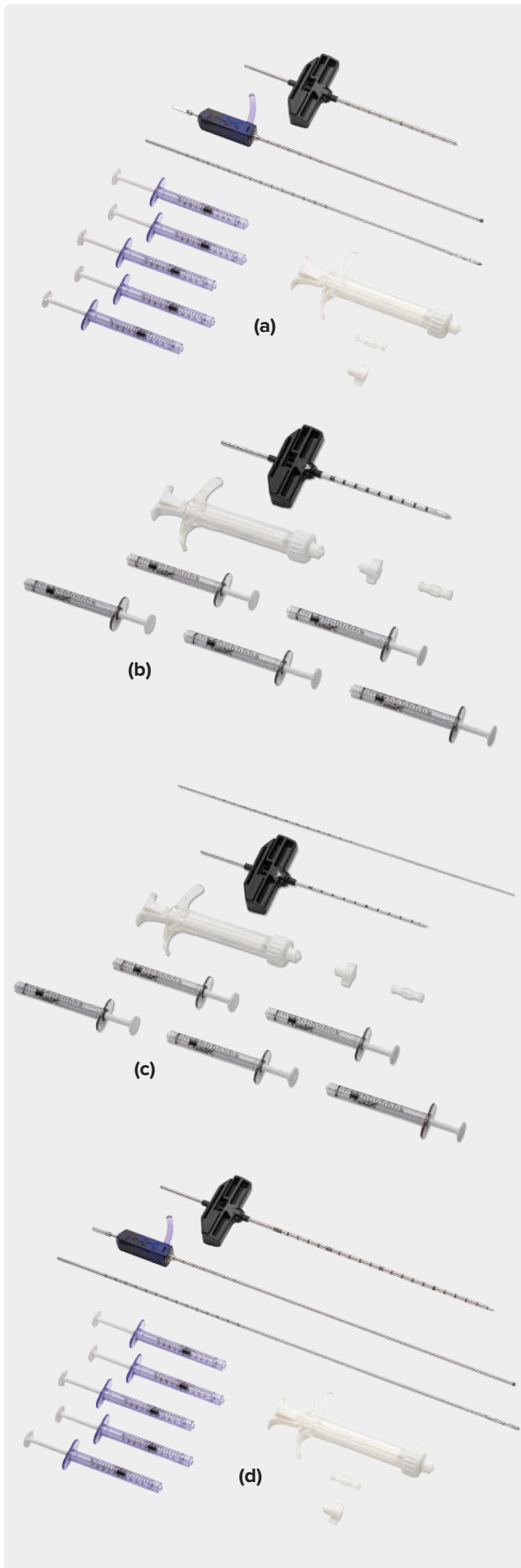

Knee IOBP® procedures

IOBP core decompression and delivery kit, open tip **(a)** ABS-2001-OT

Includes:

- > Open-tip 8 ga × 11 cm delivery cannula
- > 14 cc mixing syringe
- > 2.4 mm guide pin
- > 7 mm decompression device
- > Luer cap
- > Female-to-female Luer adaptor
- > 5 × 1 cc delivery syringes

IOBP core decompression and delivery kit, closed tip **(b)** ABS-2000-CT

Includes:

- > Closed-tip 8 ga × 11 cm delivery cannula
- > 14 cc mixing syringe
- > 5 × 1 cc delivery syringes
- > Luer cap
- > Female-to-female Luer adaptor

Foot and ankle IOBP procedures

IOBP core decompression and delivery kit, foot and ankle **(c)** ABS-2020-OT

Includes:

- > Open-tip 13 ga × 11 cm delivery cannula
- > 14 cc mixing syringe
- > 1.5 mm

Hip IOBP procedures

IOBP delivery kit w/ decompression device, open tip **(d)** ABS-2010-OT

Includes:

- > Open-tip 8 ga × 23 cm delivery cannula
- > 7 mm IOBP decompression device
- > 14 cc mixing syringe
- > 3.3 mm guide pin
- > 5 × 1 cc delivery syringes
- > Luer cap
- > Female-to-female Luer adaptor

IOBP delivery kit w/ decompression device, closed tip ABS-2010-CT

Includes:

- > Closed-tip 8 ga × 23 cm delivery cannula
- > 14 cc mixing syringe
- > 5 × 1 cc delivery syringes
- > Luer cap
- > Female-to-female Luer adaptor

Accessories

Angel® cPRP and BMA tray	ABS-10062T
Viscous-Spray, low viscosity applicator w/ 3 cm mixing tip	ABS-10051
Delivery cannula, 8 ga × 4.5 in, closed tip	RAN-811-CT
Delivery cannula, 8 ga × 6 in, open tip	RAN-815-OT
RetroConstruction™ drill guide (knee applications)	ABS-1510HR
Marking hook, femoral AC (knee applications)	ABS-1510F-01
GPS-targeting drill guide set (foot and ankle applications)	AR-8656GS
AlloSync™ Pure DBM, 2.5 cc	ABS-2010-02
AlloSync Pure DBM, 5 cc	ABS-2010-05
AlloSync DBM gel, 5 cc	ABS-2013-05
Radiopaque contrast	N/A

Soft Tissue

58	ArthroFLEX® Dermal Allograft
59	CuffMend™ Rotator Cuff Augmentation System
60	Biologic TuberoPlasty Augmentation
61	TenoWrap™ Collagen Tendon Wrap
62	Tendon Allografts: Presutured Construct Tendons
63	Tendon Allografts: Standard Grafts
64	Aseptic Tendons
65	GraftNet™ Autologous Tissue Collector for Soft Tissue
66	Arthrex Amnion™ Matrix
67	AmnionXpress™ Graft Delivery Device
68	Biovance® Human Amniotic Membrane
69	Biovance® 3L Human Amniotic Membrane
70	CentaFlex™ Decellularized Human Placental Matrix
71	Interfyl® Human Connective Tissue Matrix

ArthroFLEX® Dermal Allograft



ArthroFlex dermal allograft is an acellular dermal extracellular matrix intended for supplemental support and covering for soft-tissue repairs. Matracell® technology, a patented and validated process by LifeNet Health, renders the ArthroFlex allograft dermis acellular, without compromising biomechanical or biochemical properties. This process allows the matrix to retain its growth factors, native collagen scaffold, and elastin, which are required for healing.

- Augmentation with ArthroFlex dermal allograft has demonstrated improved clinical outcomes¹
- ArthroFlex dermal allograft improves the strength of the repair and protects the repair to allow healing^{1,2}
- Augmentation with ArthroFlex dermal allograft can reduce re-tear rates^{1,2}
- Biomechanical testing has shown that ArthroFlex dermal allograft provides high ultimate load and suture retention strength³
- ArthroFlex dermal allograft used in superior capsular reconstruction has demonstrated improved clinical outcomes and decreased pain 2 years postoperatively^{4,5}
- ArthroFlex dermal allograft has demonstrated the ability to remodel and integrate with host tissue after implantation⁶

References

1. Gilot GJ, Alvarez-Pinzon AM, Barcksdale L, Westerdahl D, Krill M, Peck E. Outcome of large to massive rotator cuff tears repaired with and without extracellular matrix augmentation: a prospective, comparative study. *Arthroscopy*. 2015;31(8):1459-65. doi:10.1016/j.arthro.2015.02.032
2. Ely EE, Figueroa NM, Gilot GJ. Biomechanical analysis of rotator cuff repairs with extracellular matrix graft augmentation. *Orthopedics*. 2014;37(9):608-614. doi:10.3928/01477447-20140825-05
3. Arthrex, Inc. Data on file. Biomechanical properties of tendon augmentation material. material (LA0822-EN, TR-492) Naples, FL; 2011.
4. Hirahara AM, Andersen WJ, Panero AJ. Superior capsular reconstruction: clinical outcomes after minimum 2-year follow-up. *Am J Orthop*. 2017;46(6):266-278.
5. Burkhart SS, Pranknum JJ, Hartzler RU. Superior capsular reconstruction for the operatively irreparable rotator cuff tear: clinical outcomes are maintained 2 years after surgery. *Arthroscopy*. 2020;36(2):373-380. doi:10.1016/j.arthro.2019.08.035
6. Hartzler RU, Softic D, Qin X, Dorfman A, Adams CR, Burkhart SS. The histology of a healed superior capsular reconstruction dermal allograft: a case report. *Arthroscopy*. 2019;35(10):2950-2958. doi:10.1016/j.arthro.2019.06.024

	LifeNet Health Part No.
Decellularized dermis, 35 mm × 35 mm × 1.5 mm	AFLEX100
Decellularized dermis, 40 mm × 70 mm × 1.5 mm	AFLEX101
Decellularized dermis, 50 mm × 90 mm × 1.5 mm	AFLEX103
Decellularized dermis, 15 mm × 140 mm × 1.5 mm	AFLEX150
Decellularized dermis, 35 mm × 35 mm × 2 mm	AFLEX200
Decellularized dermis, 40 mm × 70 mm × 2 mm	AFLEX201
Decellularized dermis, 25 mm × 30 mm × 2 mm	AFLEX202
Decellularized dermis, 20 mm × 30 mm × 3 mm	AFLEX352
Decellularized dermis, 40 mm × 50 mm × 3 mm	AFLEX300
Decellularized dermis, 40 mm × 70 mm × 3 mm	AFLEX301
Decellularized dermis, 50 mm × 60 mm × 3 mm	AFLEX302
Decellularized dermis, 40 mm × 40 mm × 1 mm	AFLEX400
Decellularized dermis, 40 mm × 70 mm × 1 mm	AFLEX401
Decellularized dermis, 20 mm × 25 mm × 1 mm	AFLEX402
Decellularized dermis, 25 mm × 30 mm × 1 mm	AFLEX403
Decellularized dermis, 30 mm × 40 mm × 0.5 mm	AFLEX500
BioWasher® decellularized dermis, 10 mm × 14 mm × 2 mm (a)	AFLEX822
Decellularized dermis, 20 mm × 30 mm × 4 mm	AFLEX602
Decellularized dermis, 25 mm × 35 mm × 4 mm	AFLEX600
Decellularized dermis, 40 mm × 70 mm × 4 mm	AFLEX601
Decellularized dermis, 25 mm × 35 mm × 5 mm	AFLEX650
Decellularized dermis, 40 mm × 70 mm × 5 mm	AFLEX651
Decellularized dermis, 20 mm × 30 mm × 5 mm	AFLEX652



CuffMend™ Rotator Cuff Augmentation System

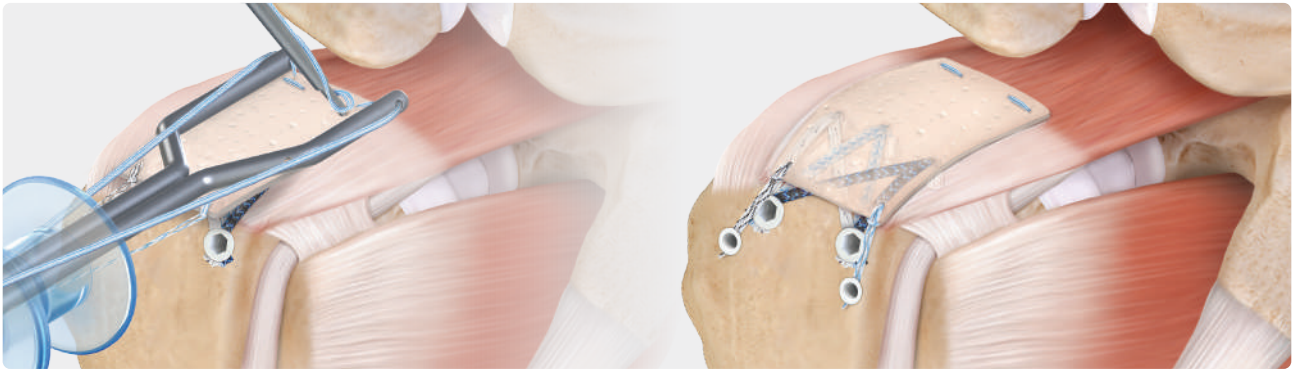

The CuffMend™ system provides an efficient, simplified approach for augmentation of partial- and full-thickness rotator cuff tears. The system employs the benefits of an ArthroFLEX® dermal allograft, which provides mechanical strength and supports healing.^{1,2} The graft is introduced using the graft spreader and attached medially with the FiberStitch™ RC implants for soft-tissue fixation to the rotator cuff tendon. This allows the augmentation to span the complete tendon length. PushLock® anchors are used, spanning the graft over the tuberosity footprint, for lateral bony fixation. Scientific literature supports the use of acellular dermal grafts as a safe and effective solution for rotator cuff augmentation.³

Implants	
CuffMend Rotator Cuff Augmentation Implant System	AR-19041S
Includes:	
▶ Two FiberStitch curved RC implants	
▶ Two 3.5 mm BC PushLock w/ SP PEEK eyelet	
▶ Three #0 FiberWire sutures w/ needles	
▶ One each FiberLink and TigerLink 0.9 mm SutureTape	
▶ HD Scorpion needle w/ MegaLoader	
▶ Graft spreader	
▶ Knot pusher/suture cutter w/portal skid	
FiberStitch 1.5 RC implant, straight w/ two polyester implants and 2-0 FiberWire®	AR-19032S
FiberStitch 1.5 RC implant, curved w/ two polyester implants and 2-0 FiberWire	AR-19032C
BioComposite PushLock anchor, 3.5 mm × 19.5 mm, self-punching PEEK eyelet	AR-1926BCSP
PEEK PushLock anchor, 3.5 mm x 19.5 mm, self-punching PEEK eyelet	AR-1926PSSP
FiberLink™ SutureTape, 0.9 mm, w/ loop (white/blue)	AR-7559
TigerLink™ SutureTape, 0.9 mm, w/ loop (white/black)	AR-7559T
0 FiberWire® suture, 38 in (blue)	AR-7254
Graft options	
ArthroFlex® dermal allograft , 25 mm × 30 mm × 2 mm, w/ Matracell® decellularized dermis	AFLEX202
ArthroFlex dermal allograft, 20 mm × 25 mm × 1.0 mm, w/ Matracell decellularized dermis	AFLEX402
ArthroFlex dermal allograft, 25 mm × 30 mm × 1.0 mm, w/ Matracell decellularized dermis	AFLEX403
ArthroFlex dermal allograft, 20 mm × 30 mm × 3.0 mm, w/ Matracell decellularized dermis	AFLEX352

Instruments	
Graft Spreader	AR-19007GS
PassPort Button™ cannula, 10 mm ID × 2 cm	AR-6592-10-20
PassPort Button cannula, 10 mm ID × 3 cm	AR-6592-10-30
PassPort Button cannula, 10 mm ID × 4 cm	AR-6592-10-40
PassPort Button cannula, 10 mm ID × 5 cm	AR-6592-10-50
10 mm PassPort inserter	AR-6592-10PI
FastPass Scorpion™ SL suture passer	AR-13999MF
HD Scorpion needle w/ MegaLoader	AR-13999HDN
FiberWire scissor	AR-11796
Knot pusher / suture cutter w/ portal skid	AR-5845

References

1. Ely EE, Figueroa NM, Gilot GJ. Biomechanical analysis of rotator cuff repairs with extracellular matrix graft augmentation. *Orthopedics*. 2014;37(9):608-614. doi:10.3928/01477447-20140825-05
2. Smith MJ, Bozynski CC, Kuroki K, Cook CR, Stoker AM, Cook JL. Comparison of biologic scaffolds for augmentation of partial rotator cuff tears in a canine model. *J Shoulder Elbow Surg*. 2020;29(8):1573-1583. doi:10.1016/j.jse.2019.11.028
3. Gilot GJ, Alvarez-Pinzon AM, Barcksdale L, Westerdahl D, Krill M, Peck E. Outcome of large to massive rotator cuff tears repaired with and without extracellular matrix augmentation: a prospective comparative study. *Arthroscopy*. 2015;31(8):1459-1465. doi:10.1016/j.arthro.2015.02.032

Biologic Tuberopecty Augmentation

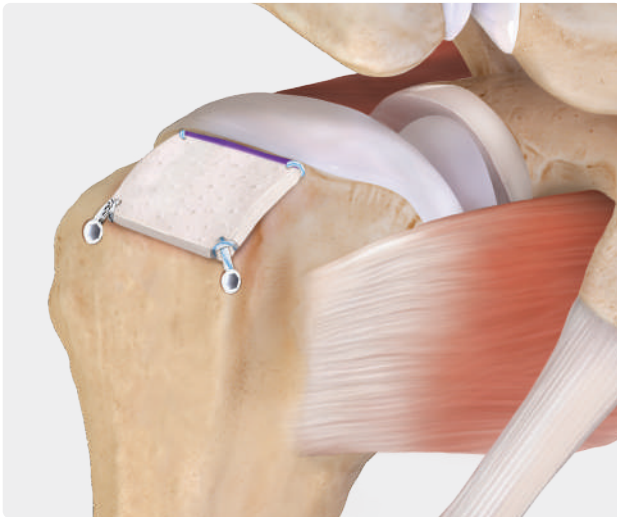

Biologic tuberopecty harnesses the power of ArthroFlex dermal allograft to provide protective support and cushioning between the acromion and tuberosity, preventing bone-on-bone contact in irreparable rotator cuff tears. Self-punching tensionable knotless technology allows the ArthroFlex graft to be placed in a quick, effective, and reproducible technique to help prevent shoulder impingement syndrome,¹ which is often associated with shoulder pain.

Implants	
Decellularized dermis, 20 mm × 30 mm × 3 mm	AFLEX352
Decellularized dermis, 25 mm × 35 mm × 4 mm	AFLEX600
Decellularized dermis, 40 mm × 70 mm × 4 mm	AFLEX601
Decellularized dermis, 20 mm × 30 mm × 4 mm	AFLEX602
Knotless 2.6 FiberTak [®] SP anchor w/ #5 suture, self-punching	AR-3641SP
BioComposite SwiveLock [®] SP anchor, 4.75 mm × 24.5 mm w/ 1.3 mm SutureTape (white/blue), self-punching PEEK eyelet	AR-2324BCSP
Optional implants	
Knotless BioComposite SwiveLock SP, 4.75 mm × 24.5 mm w/ #2 suture (blue), self-punching PEEK eyelet	AR-2324KBCSP
Knotless BioComposite SwiveLock SP anchor, 4.75 mm × 24.5 mm w/ #2 suture (blue), self-punching PEEK eyelet	AR-2324KPSP
PEEK SwiveLock SP anchor, 4.75 mm × 24.5 mm w/ 1.3 mm SutureTape, self-punching PEEK eyelet	AR-2324PSP
Bone preparation	
PowerRasp [™] instrument, 5.5 mm × 13 cm	AR-8550PR
PowerPick [™] instrument, 45°, 6 mm drill depth	AR-8150PX-45
Other	
Arthroscopic measurement probe, 60°, 220 mm	AR-4070-01
SCR guide	AR-16950SR
Back grasper w/ SR handle	AR-12531SR
PassPort Button [™] cannula, 12 mm I.D. × 3 cm	AR-6592-12-30
PassPort Button cannula, 12 mm I.D. × 4 cm	AR-6592-12-40
PassPort Button cannula, 12 mm I.D. × 5 cm	AR-6592-12-50
12 mm PassPort inserter	AR-6592-12PI
PassPort Divider, 12 mm	AR-6592-12D
FiberLink [™] SutureTape, 1.3 mm, w/ loop (white/blue)	AR-7535
TigerLink [™] SutureTape, 1.2 mm, w/ loop (white/black)	AR-7535T

Reference

1. Mirzayan R, Bouz G. Biologic Tuberopecty with an acellular dermal allograft for massive rotator cuff tears. *Arthrosc Tech*. 2021;10(7):e1743-e1749. doi:10.1016/j.eats.2021.03.016

TenoWrap™ Collagen Tendon Wrap



TenoWrap collagen tendon wrap is a resorbable, type 1 collagen matrix that provides a nonconstricting encasement for injured tendons. The graft acts as an interface between the tendon and tendon sheath or surrounding tissue. Proprietary processing techniques result in a cell-free matrix and the patented self-curling design for easy placement under, around, or over the injured tendon. TenoWrap collagen tendon wrap provides a protected environment and gliding surface for tendon healing.¹

TenoWrap collagen tendon wrap, 16 mm × 5 cm	ABS-16050
TenoWrap collagen tendon wrap, 16 mm × 2.5 cm	ABS-16025

Reference

1. Zhang F, Jacob S, Jenssen J, et al. Self-rollable type I collagen membrane for reducing adhesion in tendon surgery. Poster presented at: Society for Biomaterials Annual Meeting and Exposition; April 22-25, 2009; San Antonio, TX.

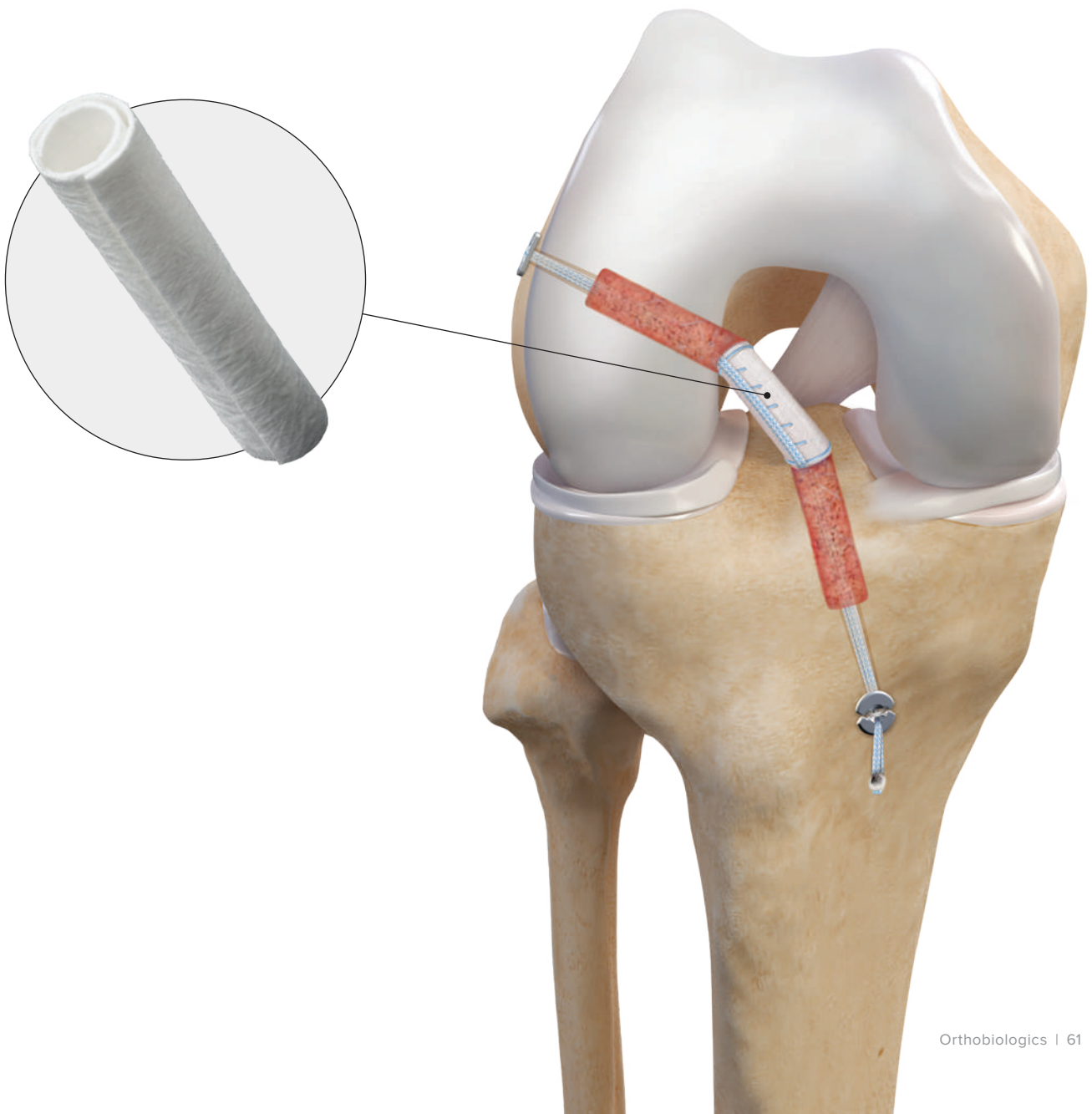

Tendon Allografts: Presutured Construct Tendons

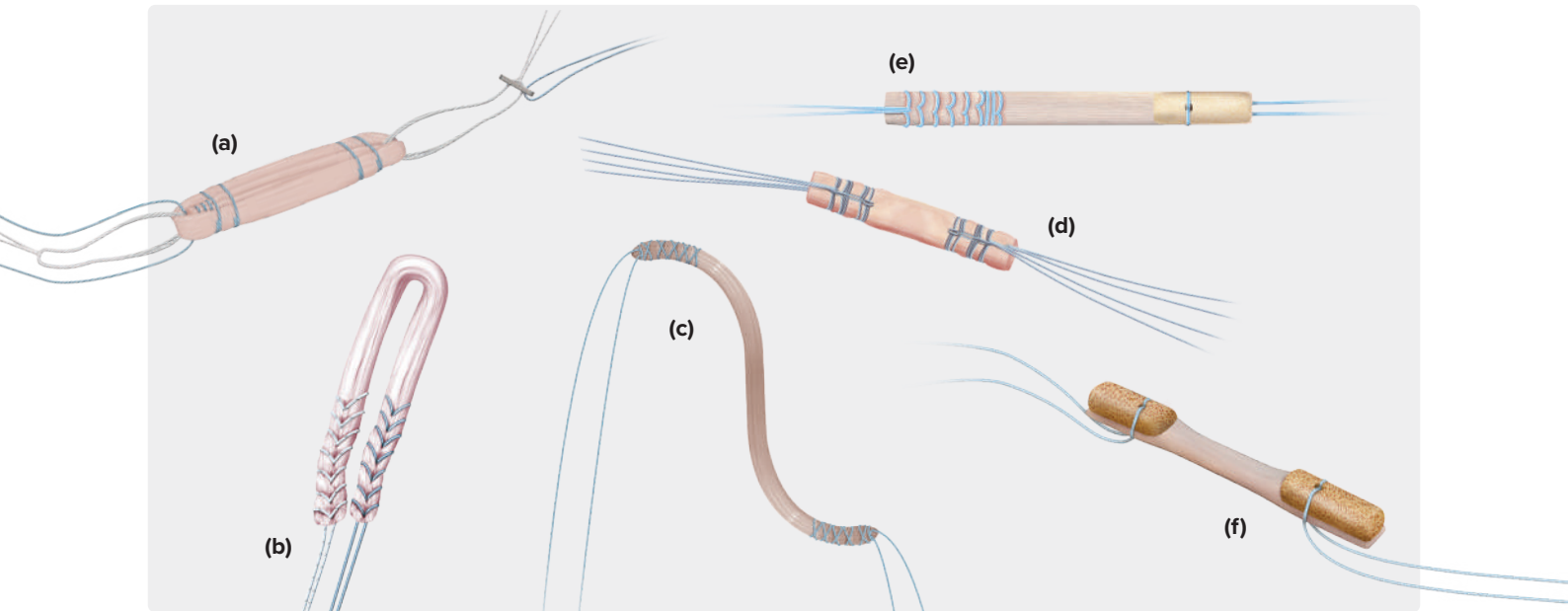

Arthrex offers a variety of presutured tendon allografts for ligament reconstruction procedures, such as ACL, PCL, ALL, MPFL, and lateral ankle procedures. These tendons are preassembled by qualified tissue technicians for consistency. Presutured tendons are terminally sterilized under low-dose, low-temperature conditions for patient safety.

The use of an allograft eliminates donor site morbidity and pain associated with the recovery of autologous tissue. The convenience of a presutured tendon allows for an off-the-shelf solution with minimal preparation time.

Construct Grafts

	JRF Ortho Part No.	LifeNet Health Part No.
GraftLink® presutured construct (a)		FGL
GraftLink TS presutured construct		FGLTS
FlexiGRAFT® connect tendon		FCON
FlexiGRAFT Connect EXT		FCONEXT
QuadLink® presutured tendon (d)	SPQ-001	FQL
DualLink® presutured construct		FDL
GraftLink XL construct (PCL)	GRX-001	
SpeedGraft® construct (b)	SPD-001	
VersaGraft® construct (c)	VRG-001	
VersaGraft 3.5 construct	VRG-351	
SpeedGraft achilles tendon (e)	PSA-101	
PilotGraft™ BTB tendon (f)	PSP-101	

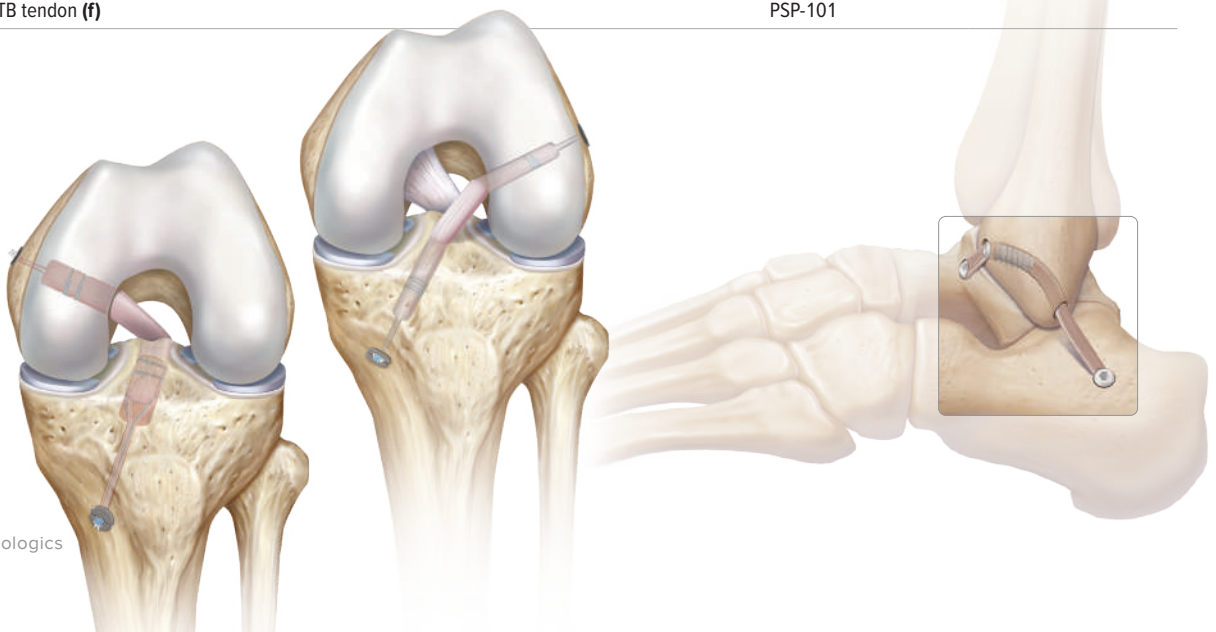

Tendon Allografts: Standard Grafts

Use of allograft tendons for primary and revision ACL and PCL reconstructions reduces OR time and eliminates the risk of donor site morbidity.¹

	JRF Ortho Part No.	LifeNet Health Part No.
Achilles tendon w/ bone block	ACT-001	FATB
Achilles tendon w/o bone block	AWO-001	FAT
Anterior tibialis tendon, short length, D ≥ 7.5 mm-11 mm, L = 170 mm-220 mm		FANT-SL
Posterior tibialis tendon, short length, D ≥ 7.5 mm-11 mm, L = 170 mm-220 mm		FPOST-SL
Peroneus longus tendon, short length, D ≥ 7.5 mm-11 mm, L = 170 mm-220 mm		FPLT-SL
Tibialis tendon, anterior	DAT-001	FANT/TIB/T
Tibialis tendon, posterior	41617000/1021-14	FPOST.TIBIAL
Gracilis, double strand	DSG-001	
Patellar tendon, bisected/hemi	HPL-001	FBPL
Patellar tendon, bisected, small block		FBPLSB
Patellar tendon, whole	WPL-001	FWPL
Patellar tendon, whole, short		FWPLSB
Patellar tendon, whole, w/ quadriceps		FWPLQ
Patellar tendon, whole, w/ extensor mechanism		FWPLQEXT
Peroneus longus, double strand	DSP-001	
Peroneus tendon		FPLT
Preshaped achilles tendon, 9 mm	ATP-091	
Preshaped achilles, 10 mm dowel diameter	ATP-101	FATB10
Preshaped achilles, 11 mm	ATP-111	FATB11
Preshaped patellar tendon, 10 mm dowel diameter	PLP-101	FPL10
Preshaped patellar tendon, 11 mm	PLP-111	FPL11
Preshaped quadriceps tendon, 10 mm	QDT-101	
Quadruple strand peroneous longus	44217004	
Quadriceps tendon w/ bone	QDT-001	FQUADB
Semitendinosus, double strand	DST-001	
Semitendinosus and gracilis tendons	QSG-001	1FST+/1FGRACILIS
Semitendinosus tendon, min L = 230 mm, min D = 4 mm		FST
Semitendinosus tendon, short length, L = 160 mm-250 mm, D = 4 mm-6 mm		FSTP
Anterior tibialis tendon, small joint	SAT-001	
Gracilis tendon, small joint	SSG-001	FGRACILIS
GraftRope		FROPE

Reference

1. Poehling GG, Curl WW, Lee CA, et al. Analysis of outcomes of anterior cruciate ligament repair with 5-year follow-up: allograft versus autograft. *Arthroscopy*. 2005;21(7):774-785. doi:10.1016/j.arthro.2005.04.112

Aseptic Tendons



Arthrex offers a full complement of aseptically processed tendons and preshaped tendons.

Aseptically processed tendons undergo advanced cleaning technologies while preserving the biomechanical integrity of the tissue.

- › Uses proprietary bioburden reduction steps that remove blood and lipids
- › Solutions do not include hydrogen peroxide, peracetic acid, or other harsh chemicals
- › Microbiology membrane filtration process for aseptic allografts
 - › The liquid culture testing method is superior to swab cultures in microbial detection¹
 - › Fluid extraction testing is more accurate because contamination is difficult to detect by swabbing the external surface of the graft²
 - › Final product is tested using microbiological verification testing per USP 71 sterility tests
 - › Strict donor screening
- › Compliance with guidelines and regulations from the American Association of Tissue Banks (AATB), Food and Drug Administration (FDA), and many other state health departments
- › No pre- or postirradiation of the tendons

Aseptic Tendons

	JRF Ortho Part No.
Achilles tendon w/ bone block	ACT-002
Achilles tendon w/o bone block	AWO-002
Achilles tendon, preshaped, 9 mm (a)	ATP-092
Achilles tendon, preshaped, 10 mm	ATP-102
Achilles tendon, preshaped, 11 mm	ATP-112
Hemi-patellar ligament	HPL-002
Whole-patellar ligament	WPL-002
Whole-patellar ligament w/ quadriceps	WPQ-002
Quadriceps tendon w/ bone	QDT-001
Quadriceps tendon w/ bone, preshaped, 10 mm	QDT-102
Patellar ligament, preshaped, 10 mm (b)	PLP-102
Patellar ligament, preshaped, 11 mm	PLP-112
Double strand semitendinosus tendon	DST-002
Double strand peroneus longus	DSP-002
Double strand anterior tibialis	DAT-002
Double strand posterior tibialis	DAP-002
Quadruple strand semitendinosus/gracilis	QSG-002
Single strand semitendinosus tendon	SST-002
Single strand anterior tibialis (c)	SAT-002

References

1. Fanelli GC, Giannotti BF, Edson CJ. Arthroscopically assisted combined anterior and posterior cruciate ligament reconstruction. *Arthroscopy*. 1996;12(1):5-1435.
2. Klimkiewicz JJ, Samsell BJ, Rif A, DeBerardino T, Moore MA. Comparison of human tendon allografts and autografts used in knee reconstruction. *Curr Orthop Pract*. 2011;22(6):494-502. doi:10.1097/BCO.0b013e318236c466

GraftNet™ Autologous Tissue Collector for Soft Tissue

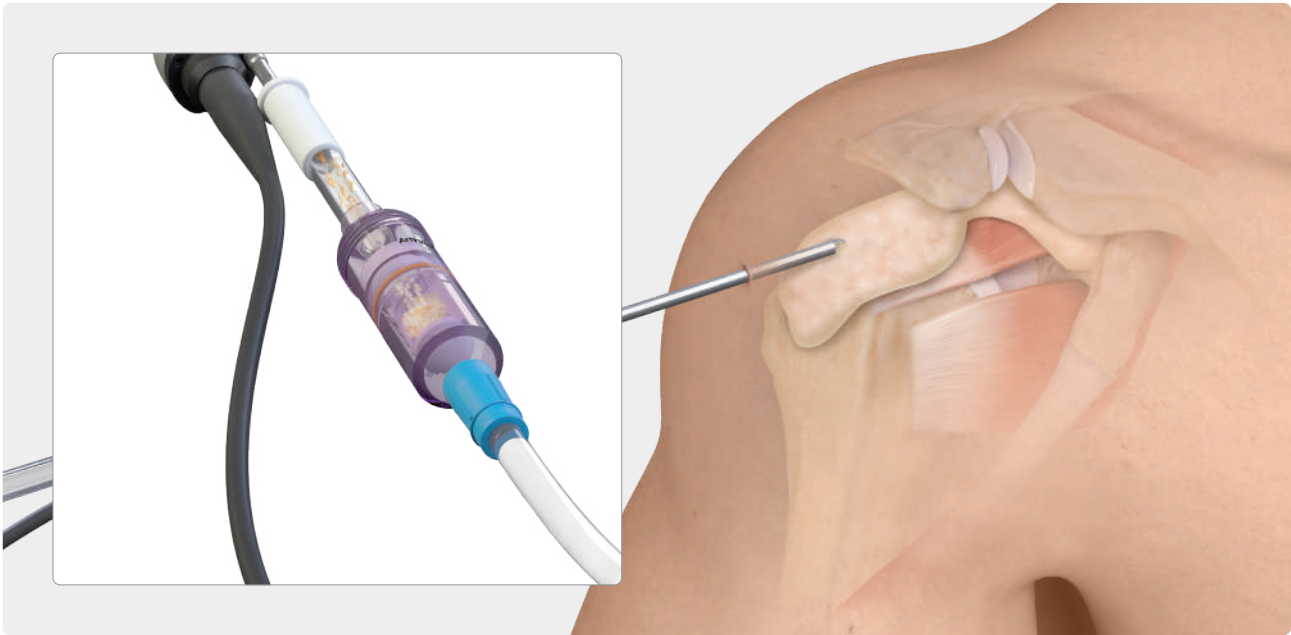

The suction-activated GraftNet device is designed to collect autologous tissue for a multitude of applications. When connected to an arthroscopic shaver, the GraftNet device may be used to remove tissue debris, soft tissue, or cartilage from a surgical site. This recovered autologous tissue is collected in an easily accessed, sterile filtered chamber. The GraftNet autologous tissue collector makes gaining access to autograft tissue as simple as Resect and Collect™.

- › Universal adapters make for easy assembly
- › Collect autologous bone, cartilage, or soft tissue
- › Quickly access recovered tissue volume
- › Control the particulate size when using a shaver device

Soft-Tissue Applications

- › Subacromial bursa during rotator cuff repair, remnant stump during ACL reconstruction, or other soft-tissue structures may be recovered and used in various procedures
- › The presence of a potential soft-tissue or wound infection often requires collecting a sample of the affected tissue
- › The GraftNet tissue collector allows for simple and effective collection of resected tissue into a sterile, closed device

GraftNet autologous tissue collector

ABS-1050

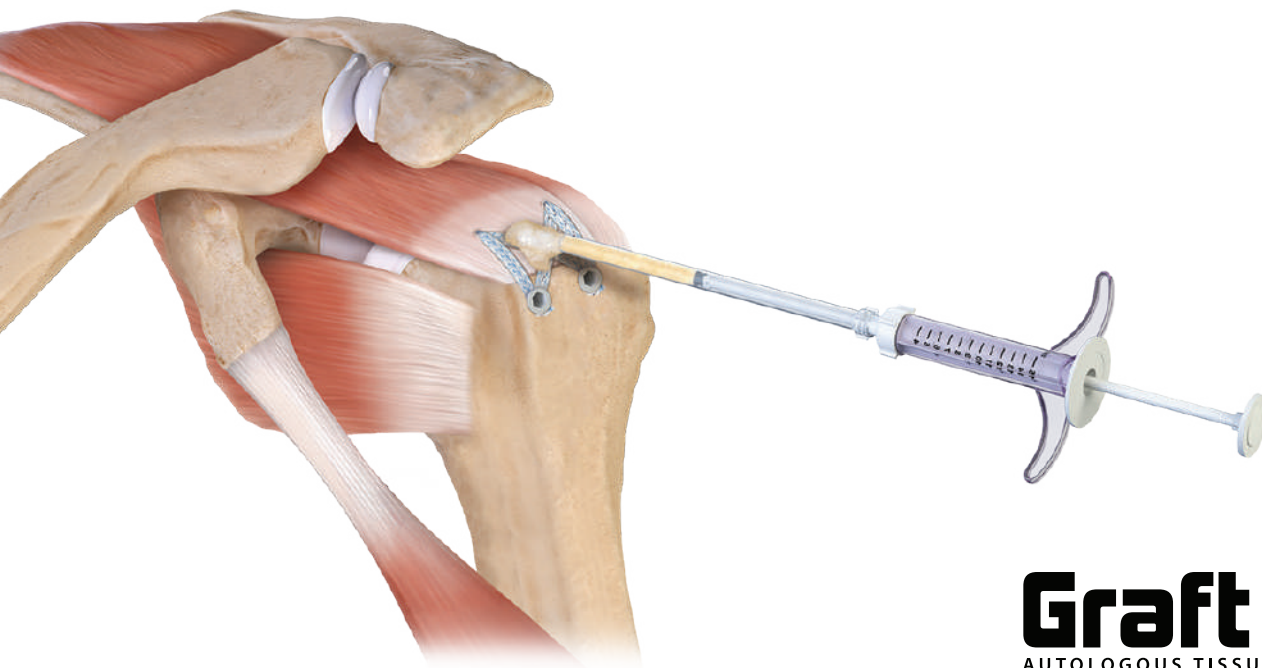

GraftNet™
AUTOLOGOUS TISSUE COLLECTOR

Arthrex Amnion™ Matrix



(a)



(b)

Amniotic-derived tissues contain endogenous growth factors and cytokines that maintain the natural properties of amnion. Arthrex Amnion matrix is an anatomical barrier that helps provide mechanical protection¹ while supporting tissues with nutrient-rich growth factors.

- › Protection: used as an anatomical wrap to act as a natural barrier (for homologous use only)
- › Easy to use: membranes are rehydrated quickly in the surgical site
- › Convenient: ambient storage (membranes) with a 5-year shelf life
- › Safe: immunoprivileged

Features and Benefits

- › Natural structural barrier
- › Rich in growth factors and cytokines

Arthrex Amnion Matrix extracellular membrane is available in 2 thicknesses and a variety of sizes.

Arthrex Amnion Matrix – Thin

This traditional single layer is a semitransparent collagenous membrane approximately 100 µm to 300 µm in thickness. As with the thicker version, Arthrex Amnion Matrix – Thin is intended for use as a soft-tissue barrier or wound covering.

Arthrex Amnion Matrix – Thick

Approximately 8× thicker than traditional amnion, Arthrex Amnion Matrix – Thick can be sutured and is easy to handle. Arthrex Amnion Matrix – Thick is derived from the umbilical cord.

Arthrex Amnion Matrix

Arthrex Amnion matrix – thin (a)

2 cm × 2 cm	ABS-4100-022
2 cm × 3 cm	ABS-4100-023
4 cm × 4 cm	ABS-4100-044
4 cm × 6 cm	ABS-4100-046
7 cm × 7 cm	ABS-4100-077

Arthrex Amnion matrix – thick (b)

2 cm × 2 cm	ABS-4200-022
2 cm × 3 cm	ABS-4200-023
3 cm × 3 cm	ABS-4200-033
3 cm × 4 cm	ABS-4200-034
3 cm × 6 cm	ABS-4200-036
3 cm × 8 cm	ABS-4200-038
5 mm × 40 mm	ABS-4200-054

Reference

1. Kim SS, Sohn SK, Lee KY, Lee MJ, Roh MS, Kim CH. Use of human amniotic membrane wrap in reducing perineural adhesions in a rabbit model of ulnar nerve neurotomy. *J Hand Surg Eur.* 2010;35(3):214-219. doi:10.1177/1753193409352410

AmnionXpress™ Graft Delivery Device

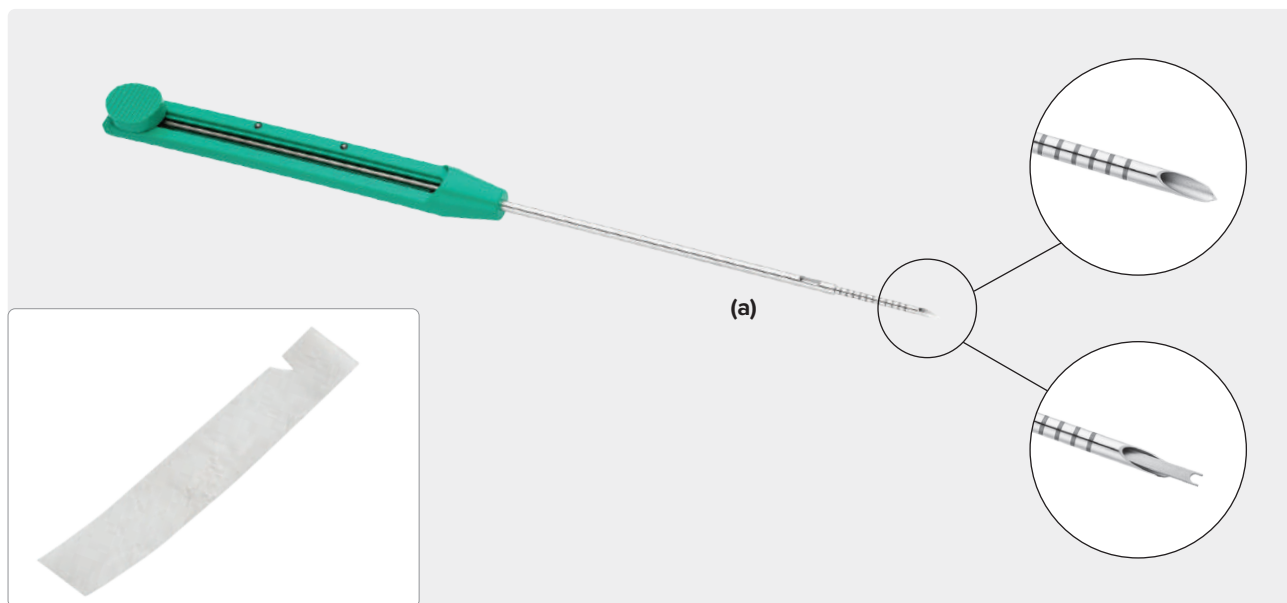

The AmnionXpress delivery device is designed for targeted delivery of soft tissue to an orthopedic surgical site. The 5 mm × 40 mm strip of Arthrex Amnion™ matrix and the 0.5 cm × 4 cm CentaFlex™ placental matrix are specifically designed for the AmnionXpress delivery device for a variety of applications, such as rotator cuff repair, ACL reconstruction and repair, Achilles repair, and patellar tendon injuries.

AmnionXpress delivery device (a)	ABS-4400
Amnion matrix - thick, 5 mm × 40 mm	ABS-4200-054
CentaFlex placental matrix, 0.5 cm × 4 cm	HPM-0054

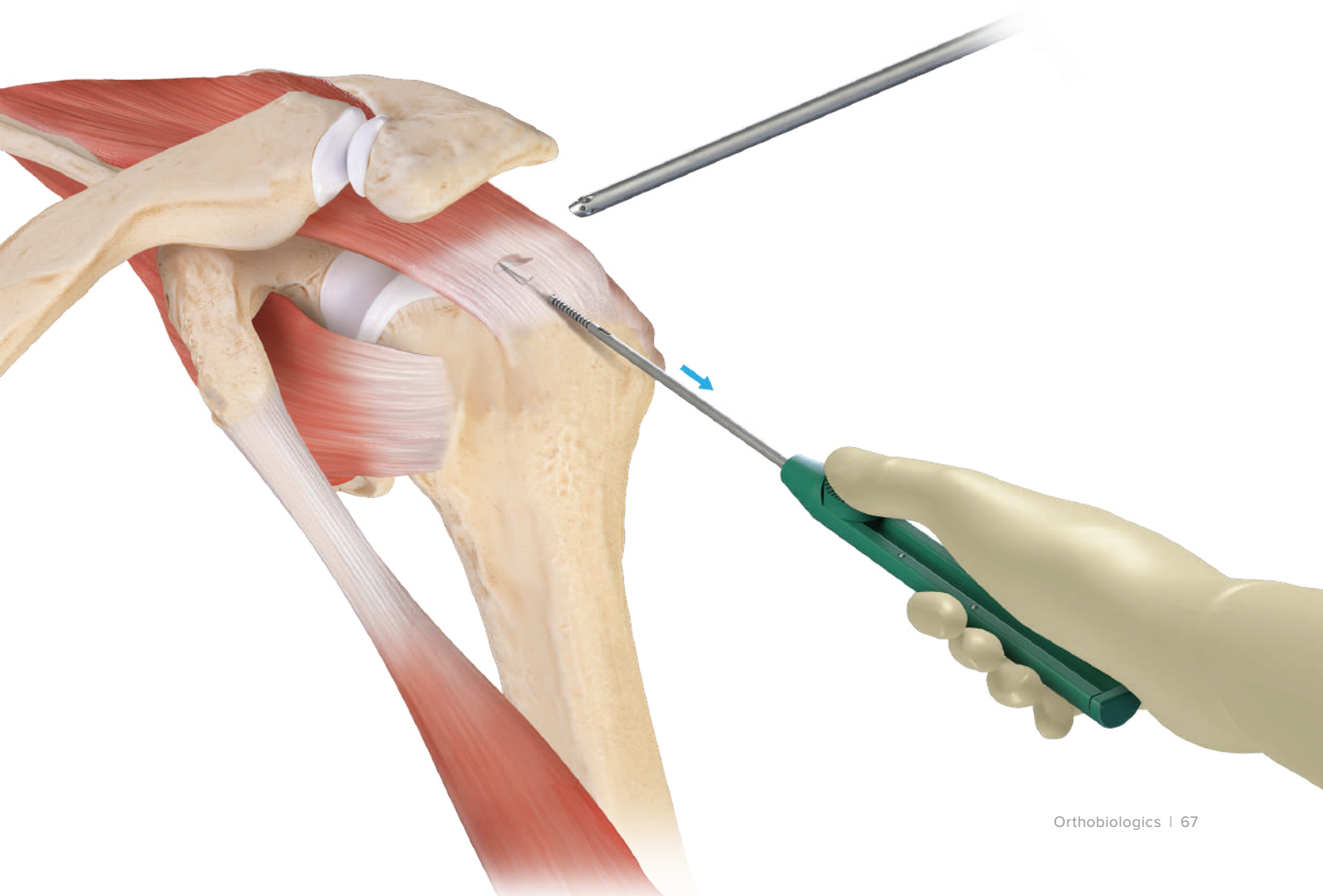

Biovance® Human Amniotic Membrane



Biovance human amniotic membrane supports tissue restoration. Biovance serves as a natural scaffold with an intact basement membrane that has been found to support a high level of fibroblast and keratinocyte attachment.¹

Designed for ease of use in surgical and nonsurgical settings, Biovance membrane offers the following features and benefits:

- › Requires no preparation
- › Can be applied in any orientation
- › Requires no sutures
- › Room temperature storage
- › 10-year shelf life

Study found a statistically significant decrease in cases of incisional dehiscence with the use of Biovance.²

Biovance amniotic membrane, 1 cm × 2 cm	DHAM0012
Biovance amniotic membrane, 2 cm × 2 cm	DHAM0022
Biovance amniotic membrane, 2 cm × 3 cm	DHAM0023
Biovance amniotic membrane, 2 cm × 4 cm	DHAM0024
Biovance amniotic membrane, 3 cm × 3.5 cm	DHAM0035
Biovance amniotic membrane, 4 cm × 4 cm	DHAM0044
Biovance amniotic membrane, 5 cm × 5 cm	DHAM0055
Biovance amniotic membrane, 6 cm × 6 cm	DHAM0066

Primary Endpoint: Complications of Wound Dehiscence (%)

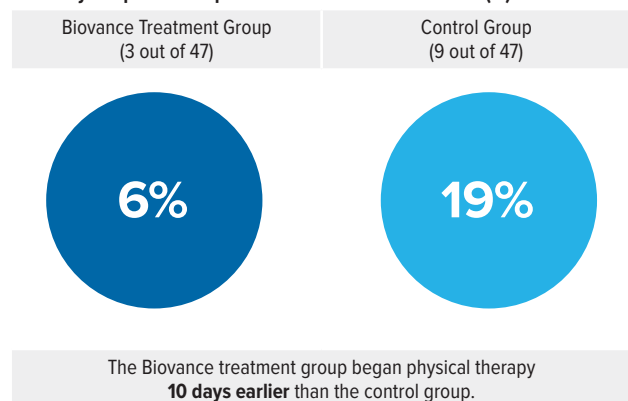

Achieving early range of motion is important to a successful outcome and reduction of stiffness following total ankle replacement.

References

1. Bhatia M, Pereira M, Rana H, Stout B, Lewis C, Abramson S. The mechanism of cell interaction and response on decellularized human amniotic membrane: Implications in wound healing. *Wounds*. 2007;19(8):207-217.
2. Brigido SA, Riniker ML, Protzman NM, Constant DD application of acellular amniotic scaffold following total ankle replacement: a retrospective comparison. *Clin Res Foot Ankle*. 2018;6(275). doi:10.4172/2329-910X.1000275

Biovance® 3L Human Amniotic Membrane

Biovance 3L membrane's unique 3-layer construction is designed for improved handling and ease of use when used as a covering, barrier, or wrap to surgical sites.

Features and Benefits

- › Pure human amniotic tissue with an intact basement membrane¹
- › Devoid of cells, hormones, growth factors, and cytokines
- › Serves as a cell-friendly structure that promotes cell attachment within hours
- › Cell attachment is a natural stimulus for the orderly release of growth factors and cytokines
- › Easy to handle: triple-layer design is thicker than other single-layer amnion products
- › Easy to use: No preparation required
- › Conforms easily to irregular surfaces
- › Triple-layer design allows for suturing if needed
- › Product has a 10-year shelf life and is stored at ambient room temperature

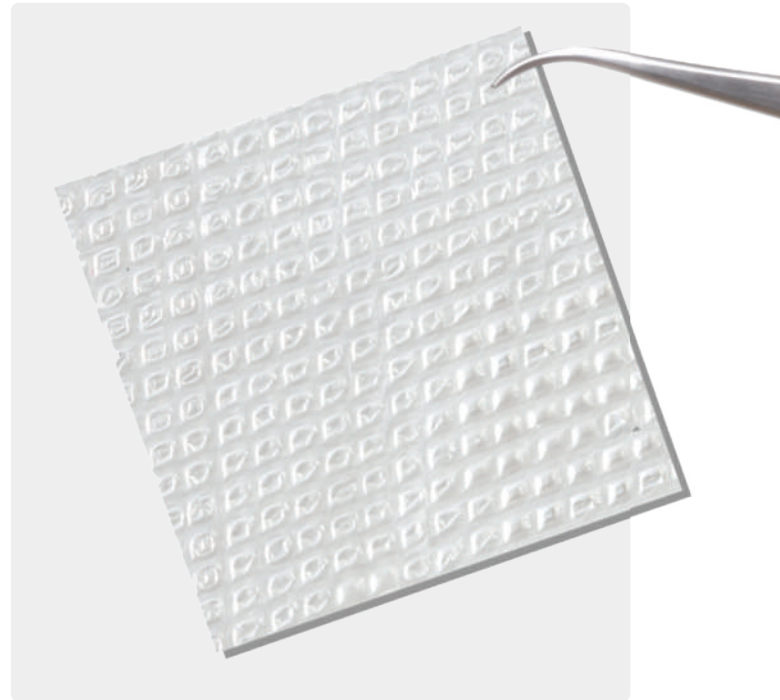

Biovance 3L membrane allograft, 2 cm × 4 cm	DHAM024S
Biovance 3L membrane allograft, 4 cm × 4 cm	DHAM044S
Biovance 3L membrane allograft, 3 cm × 6 cm	DHAM036S
Biovance 3L membrane allograft, 10 cm × 12 cm	DHAM012S

Reference

1. Bhatia M, Pereira M, Rana H, et al. The mechanism of cell interaction and response on decellularized human amniotic membrane: implications in wound healing. *Wounds*. 2007;19(8):207-217

CentaFlex™ Decellularized Human Placental Matrix



CentaFlex decellularized human placental matrix is derived from human umbilical cord and provides strong, durable support for soft-tissue repairs. CentaFlex placental matrix can be used as a surgical covering, wrap, or barrier to protect and support the repair of damaged tissue.

Features and Benefits

- › Robust and strong to hold a suture
- › Flexible to use across a wide variety of applications
- › Biologic membrane supports the body's healing process
- › Terminally sterile with 10-year shelf life
- › Ambient room temperature storage
- › Non-side-specific, can be placed regardless of orientation

CentaFlex placental matrix, 3 cm × 8 cm	HPM0038
CentaFlex placental matrix, 3 cm × 6 cm	HPM0036
CentaFlex placental matrix, 3 cm × 4 cm	HPM0034
CentaFlex placental matrix, 2 cm × 3 cm	HPM0023
CentaFlex placental matrix, 3 cm × 3 cm	HPM0033
CentaFlex placental matrix, 2 cm × 2 cm	HPM0022
CentaFlex placental matrix, 0.5 cm × 4 cm	HPM0054

Interfyl® Human Connective Tissue Matrix

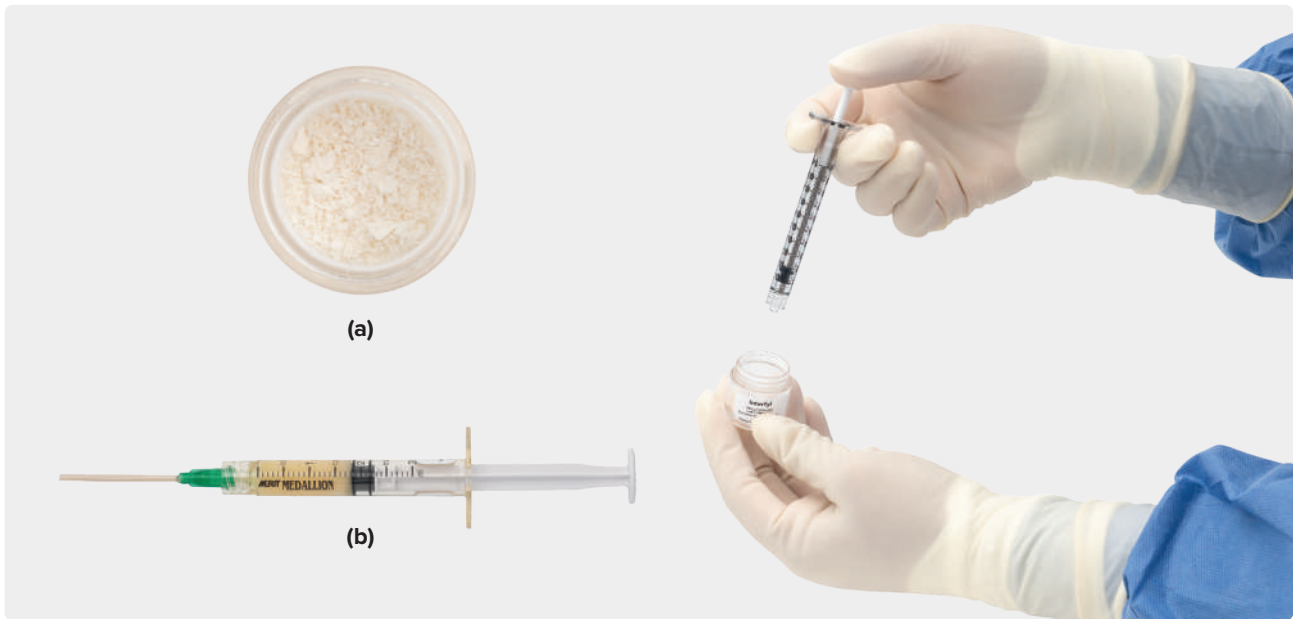

Interfyl human connective tissue matrix is derived from the chorionic plate of the human placenta, helping to replace and supplement damaged tissue. Interfyl tissue matrix is available in flowable and particulate forms to meet a variety of surgical application needs. Minimally processed Interfyl tissue matrix helps retain the fundamental structure and functional characteristics of native connective tissue.

Features and Benefits

- › Highly adaptable and suited for a variety of surgical applications where there is a need to replace or supplement damaged or inadequate integumental tissue
- › Can fill irregular spaces and conform to challenging contours
- › Completely decellularized
- › Ready to use with room temperature storage
- › 10-year shelf life

Interfyl tissue matrix, 50 mg particulate (a)	HCTM050
Interfyl tissue matrix, 100 mg particulate	HCTM100
Interfyl tissue matrix, 0.3 mL flowable	HCTM030
Interfyl tissue matrix, 0.6 mL flowable	HCTM060
Interfyl tissue matrix, 1 mL flowable	HCTM010
Interfyl tissue matrix, 1.5 mL flowable (b)	HCTM015



Surgical Incision Management

- 74 | JumpStart® Antibacterial Wound Dressing
- 75 | Energel® Wound Hydrogel
- 76 | JumpStart® FlexEFit™ Antibacterial Wound Dressing
- 76 | JumpStart ClearFit™ Dressings
- 77 | JumpStart® Pin-Site Dressing Kit

JumpStart® Antibacterial Wound Dressing

JumpStart Dressing Powered by V.Dox™ Technology

JumpStart dressings are provided on an ultra-thin, lightweight, polyester substrate and contain laser-cut fenestrations to allow easy passage of wound exudate into the absorbent layer or a secondary dressing. The flexible design easily contours to the body. JumpStart dressings can be applied directly over sutures, staples, Steri-Strip™ wound closures, and liquid skin adhesives. The dot matrix pattern of embedded microcell batteries generate microcurrents on the dressing surface in the presence of a conductive medium, such as sterile saline, water-based gel, or wound exudate.

Reduce Risk of Infection

- › Kills a broad spectrum of pathogens, including multidrug-resistant and biofilm-forming bacteria¹⁻³
- › In preclinical studies, disrupts existing biofilm infection and prevents biofilm from forming⁴
- › Prevents bacterial growth, with sustained antibacterial impact for up to 7 days⁵
- › Demonstrates improved antibacterial impact versus silver dressings⁴

Promote Healing

- › Improved re-epithelialization with JumpStart dressings versus standard dressings⁶

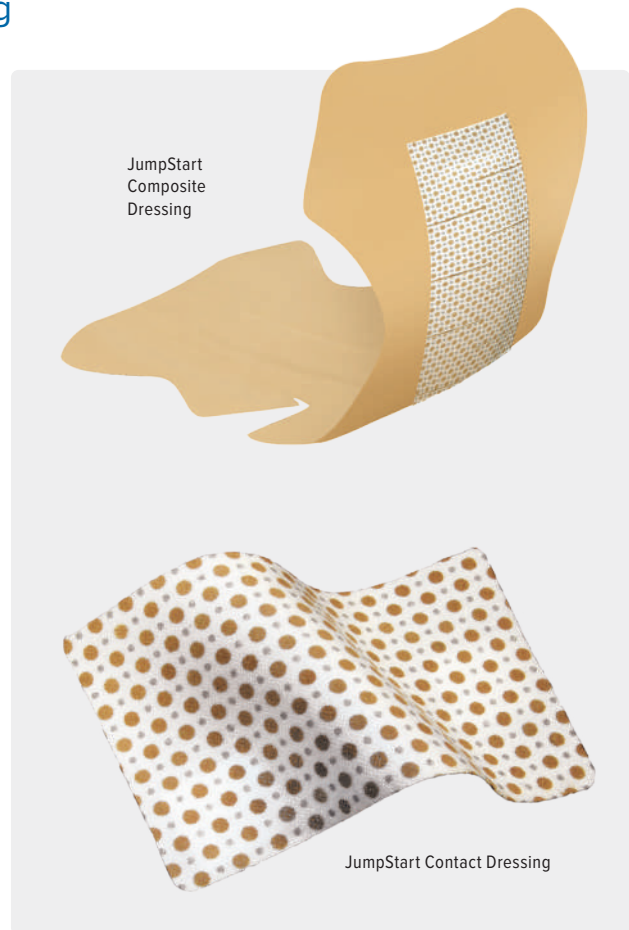

JumpStart Contact Layer Dressing

Dressing Size (in)	Qty/Box	Item Number
1 × 1 fenestrated	10	ABS-4001
1.5 × 8	10	ABS-4005
1.5 × 10	10	ABS-4006
2 × 2	10	ABS-4002
2 × 5	10	ABS-4025
3 × 3	10	ABS-4003
4 × 4	10	ABS-4004
8 × 8	1	ABS-4008
12 × 12	1	ABS-4012

JumpStart Composite Dressing

Adhesive Size (in)	Dressing Size (in)	Qty/Box	Item Number
2.5 diameter	1 diameter	10	ABS-4054
4 diameter	1 diameter	10	ABS-4056
4 × 4	2 × 2	5	ABS-4053
5 × 6	1.5 × 5	5	ABS-4051
4.5 × 10	1.5 × 7	5	ABS-4052
6 × 11.5	2 × 9	5	ABS-4050
4.4 × 9.6	1.5 × 6.5	5	ABS-4057
4.2 × 7.5	1.4 × 4.5	5	ABS-4058



V.Dox is a trademark of Vomaris Innovations, Inc.

Energel® Wound Hydrogel

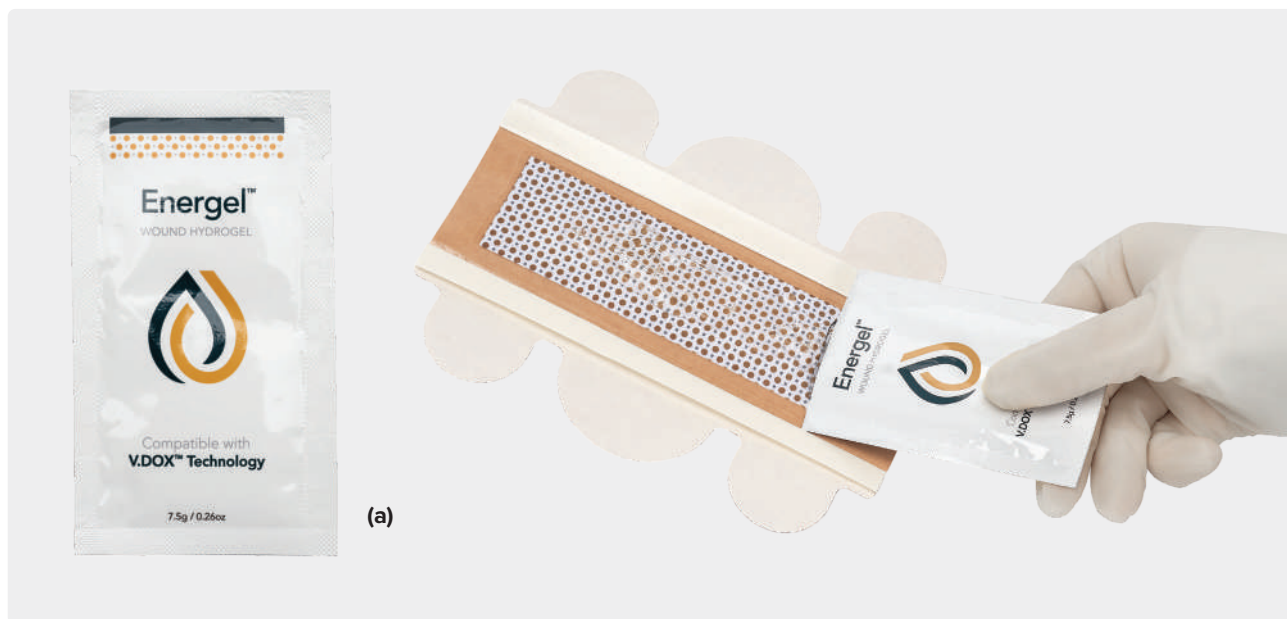

Energel® Wound Hydrogel Features

Use Energel wound hydrogel to activate JumpStart® dressing's microcell batteries:

- › Sterile, water-soluble gel formulated to maintain a moist wound environment and provide moisture to a dry wound
- › Double-packaged sterile for use in the operating room
- › Optimally sized for single use (7.5 g)
- › Maintains conductivity of JumpStart dressing for up to 7 days

Energel wound hydrogel (a)

AGL-L075-10

Energel is a registered trademark of Vomarix Innovations, Inc.

JumpStart® FlexEfit™ Antibacterial Wound Dressing

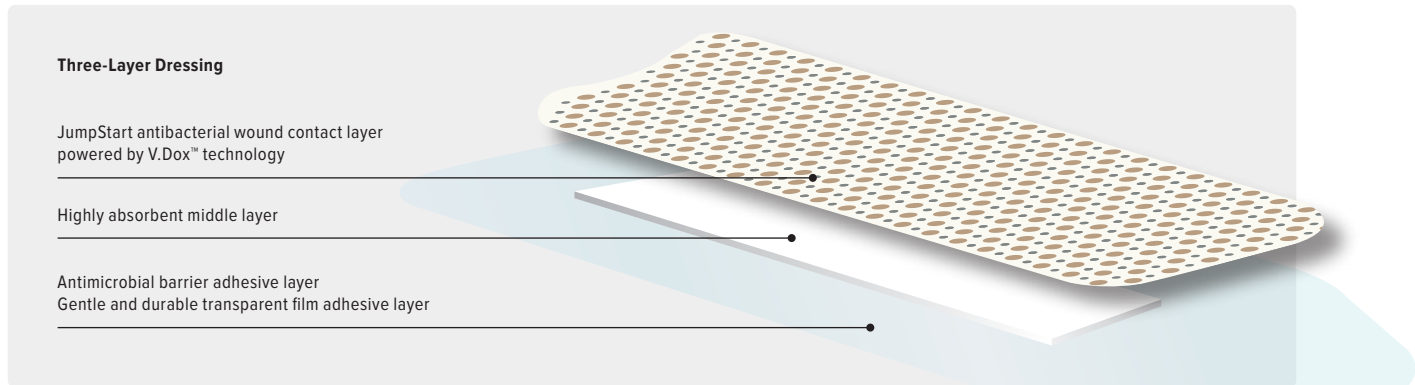

JumpStart FlexEfit antibacterial wound dressing features a patented design that enables it to link and build to universally fit virtually any incision length and curvature with just one product.

JumpStart FlexEfit dressing is exclusively powered by V.Dox technology, the only nonantibiotic, antibacterial technology that is inspired by the skin's natural electrical healing process with demonstrated antibacterial impact against a broad spectrum of bacteria, including multidrug-resistant and biofilm-forming bacteria.¹⁻³

Reduce the risk of infection and promote wound healing with a single product that can meet virtually all postsurgical dressing needs.

JumpStart FlexEfit Wound Dressings

Dressing Dimensions	Adhesive Dimensions	Qty/Box	Item Number
1.5 × 4.5 (in)	2.5 × 6.3 (in)	5	ABS-4060-05
3.8 × 11.4 (cm)	6.3 × 16 (cm)	10	ABS-4060-10

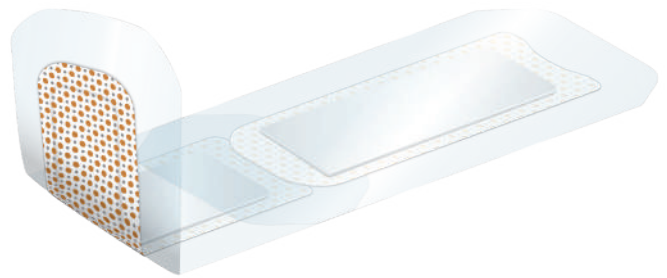

JumpStart ClearFit™ Dressings

The JumpStart ClearFit dressing line features the unique V.Dox technology with a clear film adhesive for gentle dressing placement and removal.

JumpStart ClearFit dressing, 4 in × 4 in	ABS-4061
JumpStart ClearFit dressing, 6 in × 6 in	ABS-4062
JumpStart ClearFit dressing, 3.5 in × 2.25 in	ABS-4063

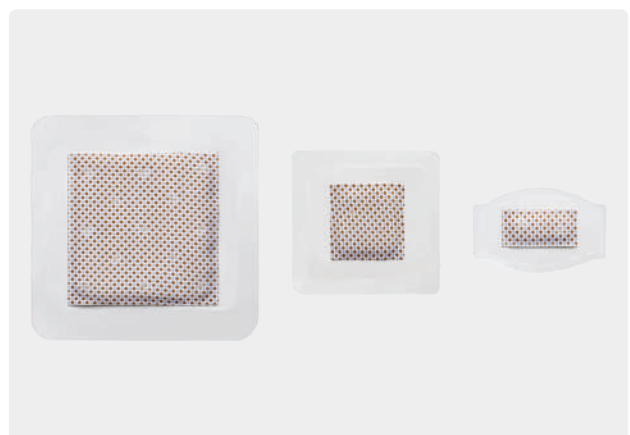

JumpStart® Pin-Site Dressing Kit



The JumpStart pin-site dressing kit includes three products: one JumpStart dressing pad, one absorbent gauze, and one holding clip. The 2-in diameter JumpStart dressing is easily placed over external fixation device pins to protect against a broad spectrum of bacteria while also promoting a more natural healing process. The absorbent disk and holding clip help maintain a moist wound environment, the optimal environment for healing when using JumpStart dressing.

Features and Benefits

- › Perfectly sized to fit around external fixation devices
- › V.Dox™ technology is effective against multidrug-resistant bacteria and disrupts biofilm matrix
- › Promotes healing
- › Easy and simple to use
- › Single use
- › Can be left on for up to 7 days^a

^aAbsorbent pad can be changed if exudate levels are high

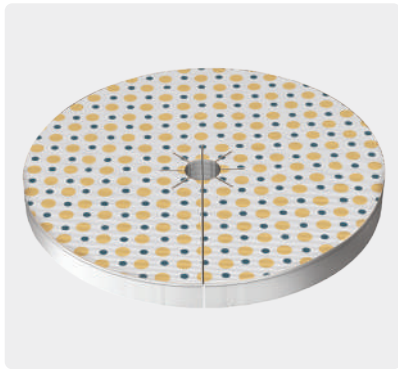

JumpStart pin-site dressing kit

ABS-4059

References

1. Kim H, Makin I, Skiba J, et al. Antibacterial efficacy testing of a bioelectric wound dressing against clinical wound pathogens. *Open Microbiol J.* 2014;8:15-21. doi:10.2174/1874285801408010015
2. Banerjee J, Ghatak P, Roy S, et al. Silver-zinc redox-coupled electroceutical wound dressing disrupts bacterial biofilm. *PLoS One.* 2015;1-15. doi:10.1371/journal.pone.0119531
3. Kim H, Izadjoo M. Antibiofilm efficacy evaluation of a bioelectric dressing in mono and multi-species biofilms. *J Wound Care.* 2015;24 Suppl 2:S10-S14. doi:10.12968/jowc.2015.24.Sup2.S10
4. Barki K, Das A, Dixith S, et al. Electric field based dressing disrupts mixed species bacterial biofilm infection and restores functional wound healing. *Ann Surg.* 2019;269(4):756-766. doi:10.1097/SLA.0000000000002504.41
5. Vomarix Innovations, Inc. Data on file (SLM090512CMC01F). Tempe, AZ.
6. Blount A, Foster S, Rapp D, et al. The use of bioelectric dressings in skin graft harvest sites: a prospective case series. *J Burn Care Res.* 2012;33(3):354-357. doi:10.1097/BCR.0b013e31823356e4



This description of technique is provided as an educational tool and clinical aid to assist properly licensed medical professionals in the usage of specific Arthrex products. As part of this professional usage, the medical professional must use their professional judgment in making any final determinations in product usage and technique. In doing so, the medical professional should rely on their own training and experience, and should conduct a thorough review of pertinent medical literature and the product's directions for use. Postoperative management is patient-specific and dependent on the treating professional's assessment. Individual results will vary and not all patients will experience the same postoperative activity level or outcomes.



Arthrex manufacturer, authorized representative, and importer information (Arthrex eIFUs)



US patent information

ORFIOIORS