

FEATURES

- A constant power output LED emergency driver, wide output voltage range, constant output power with high precision;
- Abnormal Protection:
 - Battery overcharge protection
 - Battery over-discharge protection
 - Output overload protection
 - Short-circuit protection
 - Open load protection
 - No-load protection
- Monthly/Annually self-inspection.

ELECTRICAL SPECIFICATIONS

- Input voltage: 120-277V AC 50Hz /60Hz
- Input current: 0.08A max
- Input power: < 7W
- Power factor: 0.6 @120V AC, 0.5@277V AC, 0.4@347V AC
- Battery: LiFePO4 / Lithium
- Recharge duration:24Hrs
- Emergency duration: ≥90mins
- Ambient temp: 0-50°C, 32°F-122°F

4W/5W/8W/11W



16W

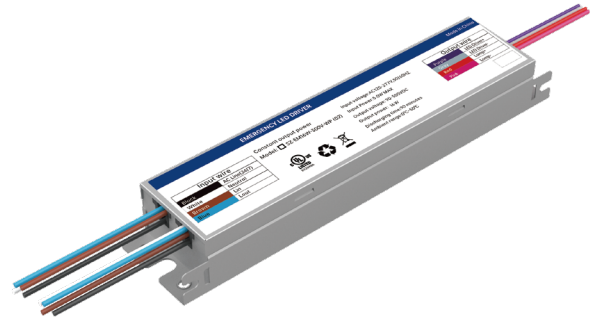

Remote control



5 years Warranty



IP20 IP Rating



UL US LISTED



Li-ion



BC

Self Test

CONSTANT POWER EMERGENCY OUTPUT

MODEL SELECTION TABLE

Models	Output Voltage	Battery Type	Emergency Power	Battery Capacity	LED Driver Output Current	Max.load
SZ-EM4W-300V-WP (02)	300V DC Max.	LiFePO4	4W	6.4V 1600mAh	3A Max.	150W
SZ-EM5W-300V-WP (02)	300V DC Max.	Lithium	5W	7.2V 2000mAh	3A Max.	150W
SZ-EM8W-300V-WP (02)	300V DC Max.	Lithium	8W	7.2V 2600mAh	3A Max.	200W
SZ-EM11W-300V-WP (02)	300V DC Max.	Lithium	11W	7.2V 3300mAh	3A Max.	200W
SZ-EM16W-300V-WP (02)	300V DC Max.	Lithium	16W	10.8V 3300mAh	3A Max.	200W

NORMAL MODE

Fixtures will operate normally when power is available. When an outage occurs, the fixture will switch to emergency mode, delivering power to the fixture for up to 90 minutes.

EMERGENCY MODE

1. The emergency battery backup enters the emergency mode immediately after the mains power failure.
2. Stop the emergency and return to the charging state after the mains power call.

SELF-DIAGNOSTIC

MONTHLY SELF-TEST

It will automatically perform a monthly self-test every 30 days with a duration of 30S to check whether the emergency function is normal, and automatically restore to normal charging after 30S discharged.

ANNUAL SELF-TEST

An annual self-test will be done every year (12 months) with a duration of 90mins to check whether the capacity of the battery pack is normal, and automatically restore to normal charging after fully discharged. (the condition of annual test is that the battery pack is fully charged).

If the annual inspection is interrupted, it will be retested after recovery and when the test conditions are met. (Possibility of interruption: such as sudden power failure, sudden manual test).

Test button & LED indicator

Operations	Test button operations	Remote control operations	Indicator status	Working status
Normal mode	Press and hold the test button	Press button A	OFF	Emergency mode
	/	Press button B	OFF	Monthly testing
	/	Press button C	OFF	Annual testing
	/	/	ON	Battery is charging or fully charged
	Press the test button 5 times within 5S	Press button D 10S	Flashing 3 times	Bluetooth reset
Emergency mode	Press the test button 5S	/	OFF	Turn off the battery pack
Malfunction mode	/	/	Flashing	1.The battery pack is disconnected or it is broken. 2.The load is disconnected. 3.Short circuit or open circuit. 4.The wires are not connected properly.

ACCESSORIES



Waterproof test button

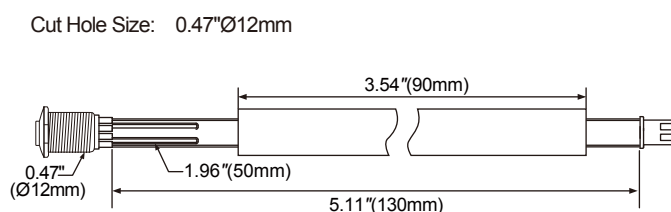

DIMENSION

4W/5W/8W/11W

L 5.31"(135mm) x W 1.69"(43mm) x H 0.98"(25mm)

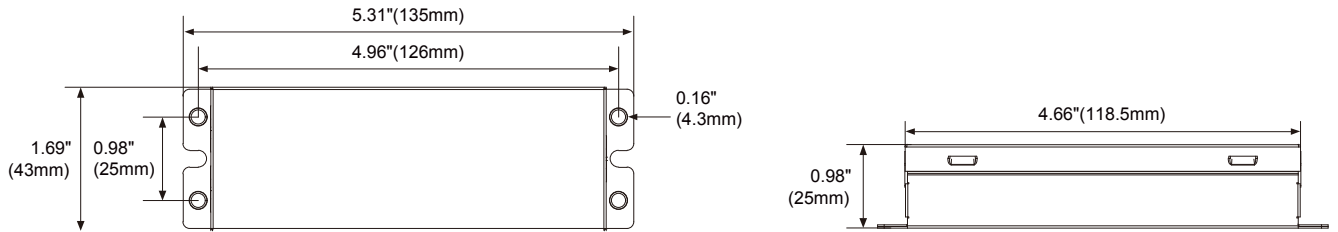

16W

L 7.67"(195mm) x W 1.65"(42mm) x H 1.02"(26mm)

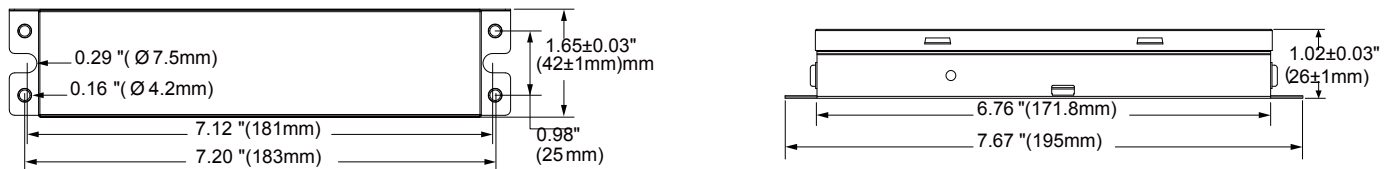

WIRING DIAGRAM

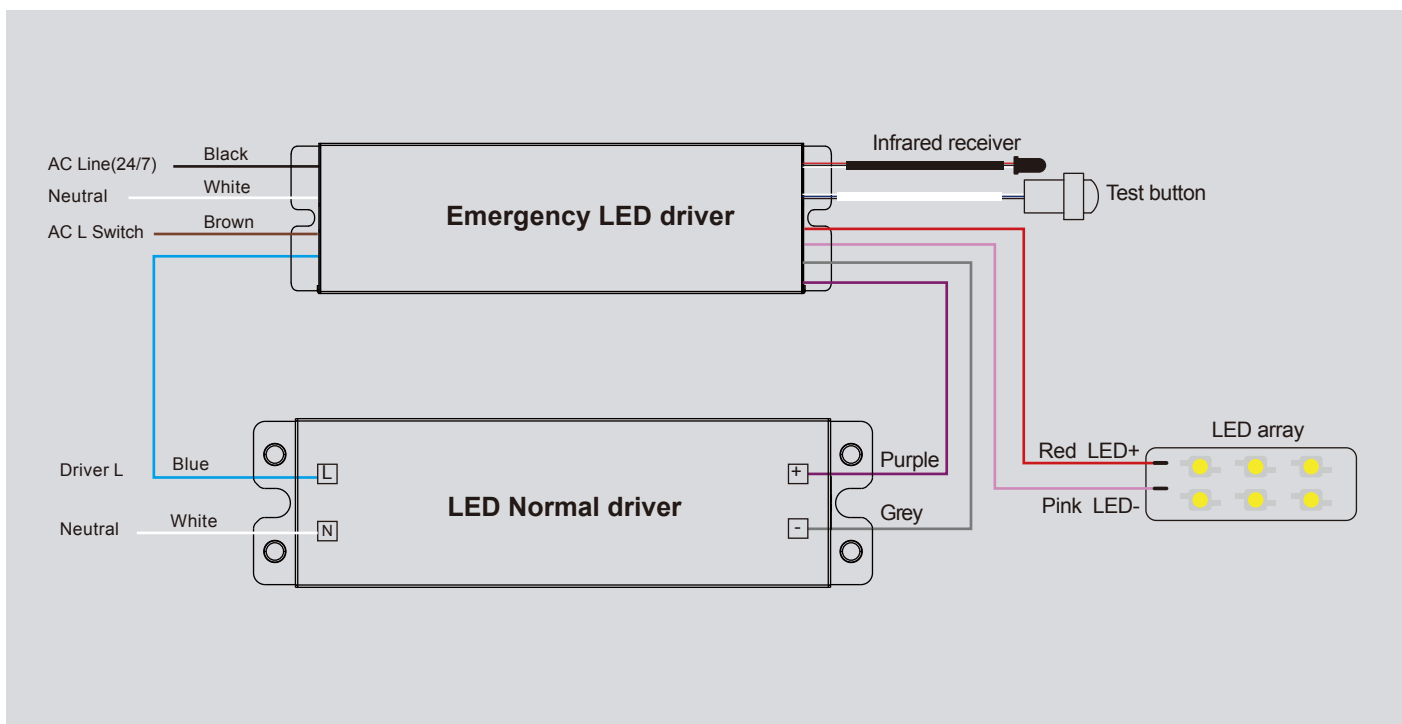

IMPORTANT SAFEGUARDS

When using electrical equipment, basic safety precautions should always be followed, including the following:



CAUTION
READ AND FOLLOW ALL SAFETY
INSTRUCTIONS



1. CAUTION – To prevent electrical shock, do not mate unit connector until installation is complete and AC power is supplied to the unit.
2. CAUTION – This fixture provides more than one power supply output source. To reduce the risk of electrical shock, disconnect both normal and emergency sources by turning off the AC branch circuit and by disconnecting the unit connector.
3. CAUTION – This is a sealed unit. Components are not replaceable. Replace the entire unit when necessary.
4. CAUTION – Installation and servicing should be performed by qualified personnel only. De-energize before opening.
5. This series is for use with grounded LED luminaires listed to UL standards. Not for use in heated air outlets or hazardous locations.
6. This series requires an unswitched AC power source of 120 to 277 volts, 50/60 Hz .
7. This series and AC driver must be on the same branch circuit.
8. Do not mount near gas or electric heaters.
9. This series should be mounted in locations and at heights where it will not readily be subjected to tampering by unauthorized personnel.
10. This series will supply 300V DC Max. output at the individual rated specification for 90 minutes.
11. Suitable for use in damp locations and plenum spaces.
12. Flexible metal conduit is optional, depends on installation environment.
13. For use in 0° C minimum, 50° C maximum ambient temperatures.
14. Do not use this equipment for other than intended use.
15. Install in accordance with the National Electrical Code and local regulations.
16. Lighting fixture manufacturers, electricians, and end-users need to ensure product system compatibility before final installation.