

## PRODUCT SPECIFICATION

MODEL NO	SZ-PS-A
INPUT	12VDC
DESCRIPTION	PHOTOCELL SENSOR
CERTIFICATE	UL
Warranty	5years

## 12VDC PHOTOCELL SENSOR

# Features & Benefits



SZ-PS-A



- Photocell Sensor, no Motion Detection.
- With Audio Jack, suitable for UFO highbay application.
- With UL certificate.

# Dimensions

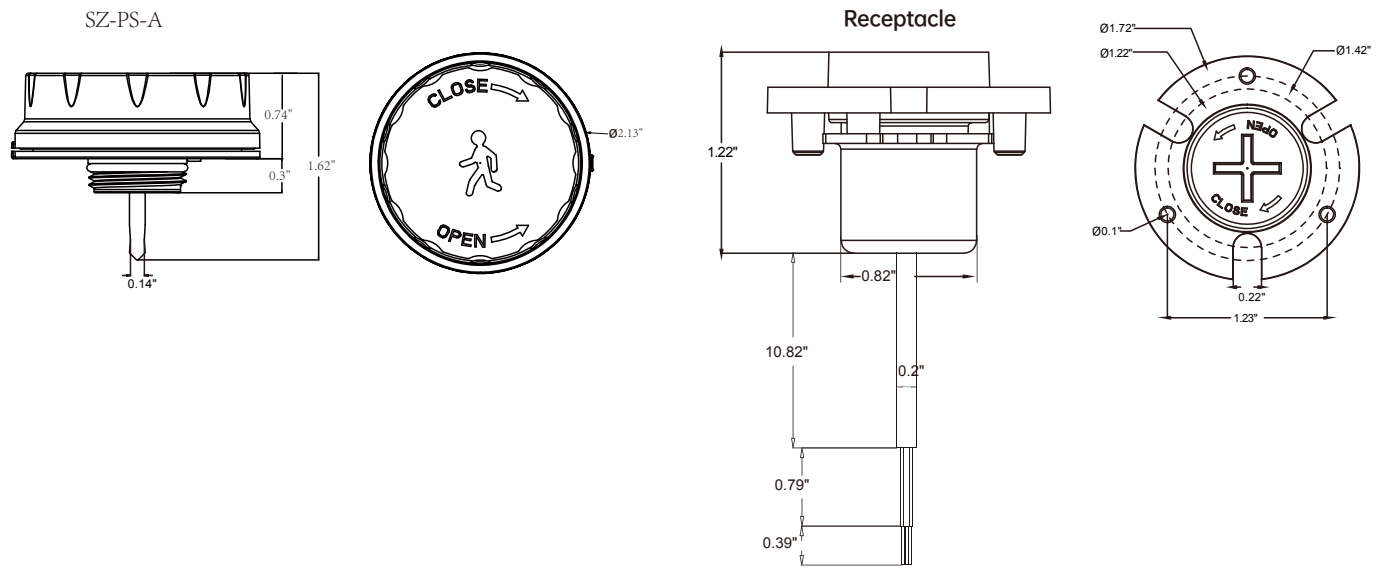

# Wiring Diagram

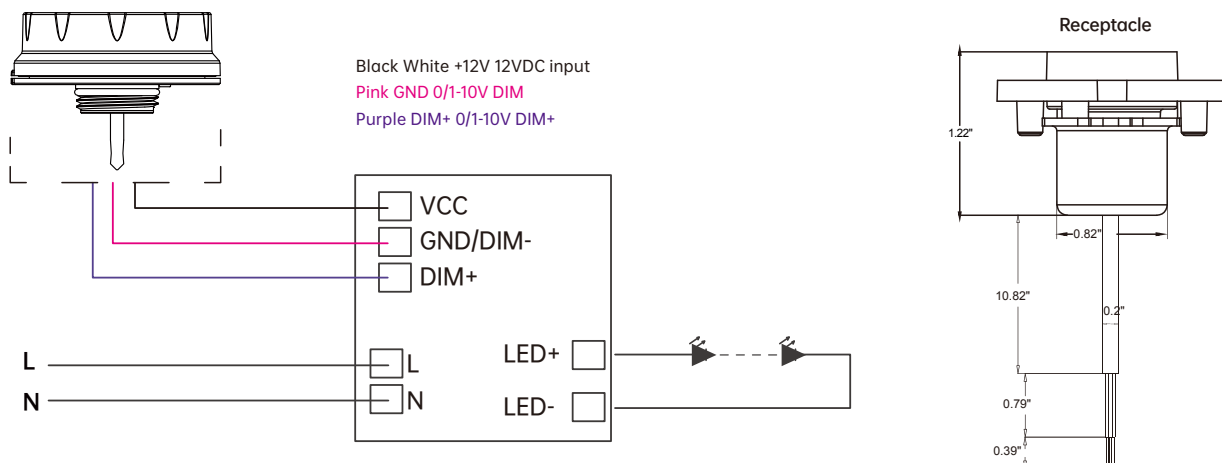

# Parameters

Model NO.		SZ-PS-A
Daylight Setting	Photocell	(Fixed Parameter) When ambient brightness darker than 20lux, sensor turns ON light; when it's brighter than 150lux, sensor turns OFF light
	Warranty	5 Years
INPUT	Input Range	12VDC
	Voltage Range	10-15VDC
	Current	≥30mA
	Stand-by Power	<10mA Power Consumption
OUTPUT	Signal	DIM 0-10V
	Connection	12VDC input/ Black&White wire; DIM+/ Purple wire; DIM-/ Pink wire
ENVIRONMENT	Working Temp	-30°C~+70°C
	Storage Temp	-40°C~+80°C Humidity: 85% (non-condensation)
CERTIFICATE & STANDARDS	Certification	UL
	Environmental Requirements	In accordance with CE ROHS
	IP Rating	IP65
PACKAGE	Silk-Printing	Lasering
	Packing Description	1pcs/white neutral box
	Qty/ctn(pcs)	200
	Net Weight/pcs (kg)	0.05
	Gross Weight/CTN (kg)	11
	Carton Size (Inch)	15.75*11.81*9.84"
Factory default settings	Daylight threshold: 30lux	

## Lux on/off

With Daylight priority function, SZ-PS-A is able to differentiate artificial light brightness from natural light after installed inside the fixture, and automatically turn off light when ambient brightness exceeds preset lux level.

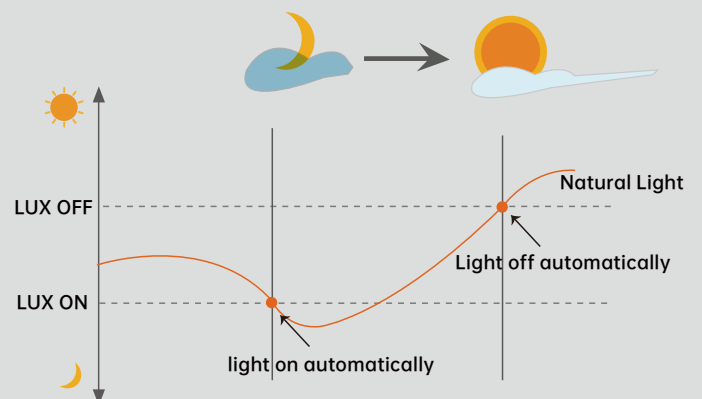

# Performance

## Application—Lux on/off

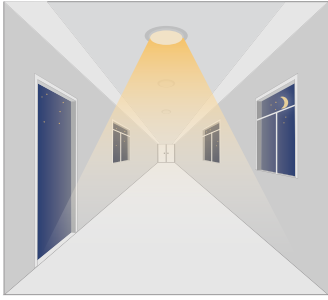

When ambient brightness is higher than preset lux level, light will automatically turn off.

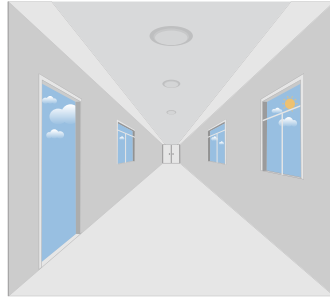

when is lower, than pre-set lux level light will turn on 100%.



## Attention

1. The sensor should be installed by qualified electrician and ensure power is OFF before installation.
2. Please read the instruction carefully before using the product and keep it well for other users to read any time.
3. We reserve the right to modify any incorrect text, image and technical parameters.
4. Any unauthorized modification is forbidden. Otherwise all guarantees will be immediately invalid.
5. Product could be optimized without prior notice.

# APPLICATION NOTES

1. Suitable for indoor application, half/completely outdoor environment conditions might be captured as moving signals to trigger the sensor.
2. Suitable for ceiling mount installation, adjust sensitivity properly if it's installed on side-wall because it gets more sensitive.
3. Adjust sensitivity properly when the sensor is applied in small/narrow/metal-built/with metal spaces.
4. Microwave sensor can't be placed under/inside metal shell; Microwave module must directly face the detection area with edge lower than light fixture.
5. Keep the sensor away from vibration equipments, air-conditioning outlets, smoke extractors alike conditions to avoid unwanted trigger.
6. Keep the sensor module away from AC input and DC output to avoid high/low frequency signal interference.
7. At least 2m/6.5ft distance between microwave sensors; 1.5m/4.9ft between the sensor and other wireless devices such as routers to avoid possible radio interference.
8. Daylight testing delivered in bright day without shadow or specially designed lampshade or lens.
9. Dimming performance differs when connected to different drivers; If the driver can't completely turn OFF, sensor can't either.
10. Input power voltage must be stable with float less than 10%.
11. The first time powered ON sensor, light will be ON 100% for about 10S then dims to standby level or OFF.
12. Distance detection is delivered by testing person about 165cm in open area as reference, the result differs by size and speed of moving objects, mounting height and real-life situation.