



# MTA Eco

TWIN

Indirect heat interface unit



# MTA Eco

## TWIN

The MTA Eco Twin is an indirect twin plate heat interface unit designed to provide instantaneous domestic hot water (DHW) and space heating in an apartment or detached property when connected to a central energy source within a heat network.

The unit operates on a DHW priority basis and provides hot water when a tap or similar outlet is opened, therefore, all the energy supplied to the HIU via the heat network goes towards domestic hot water production. The production of instantaneous DHW minimises the risk of legionella bacteria multiplying since no hot water is stored. As DHW is required for a relatively short time, space heating within the property is not compromised.

The MTA Eco Twin's integrated space heating plate heat exchanger ensures that the property's heating circuit is hydraulically separated from the district circuit, so if a leak were to occur in the space heating circuit the heat network will not be affected. Furthermore, the heating circuit can operate at a low pressure because it will not be subject to the high pressure the district circuit could bear if the building is tall.

The heat interface unit is fully electronic, which allows for improved reaction times over mechanical appliances and increased efficiency gains. Without many of the components normally seen within mechanically driven HIUs, the Modutherm unit is uncomplicated, compact and lightweight. The MTA Eco Twin is equipped with a spool piece, where a heat meter could be installed, and if a heat meter is ordered from Modutherm, then the appliance will leave the factory with the heat meter fitted.

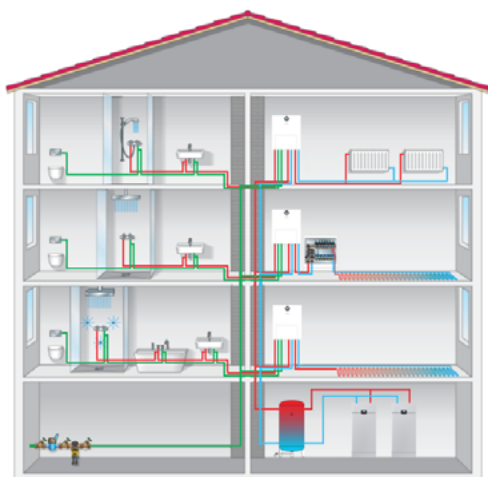
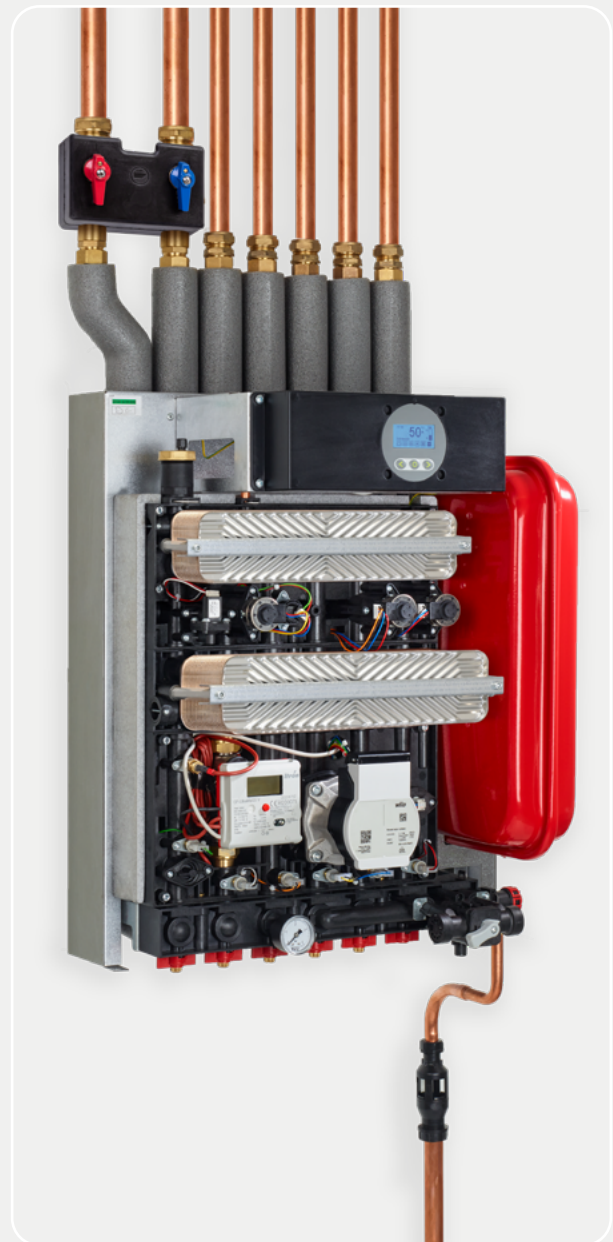

The MTA Eco Twin is fitted with a white powder-coated steel outer case beneath which is an insulated foam cover that keeps heat losses through the case and into adjacent areas to a minimum. The case has a built-in hinged flap that allows the tenant access to the heat meter (if fitted) and the apartment heat circuit fill device so that the apartment can be topped up with water from the mains cold water supply as necessary.

Modutherm's "one size fits all" solution generates instantaneous domestic hot water and space heating to satisfy the needs of a wide range of property sizes. Positioned to suit the mass market, the unit is priced very competitively, eliminating the need for Modutherm to build multiple output units to be cost-effective.

# Key Features

- SWEP AS heat exchangers
- Ultra-compact dimensions
- Fully electronic unit
- Keep warm function (On/Off/Timed)
- DHW priority
- 16bar rated
- Unique HydraBlok® back plate
- Primary flow rate limitation
- Advanced diagnostics
- Advanced pump control (anti-seizure)
- Remote connectivity
- Automatic low heating circuit pressure cut out
- Provision for fitting of underfloor safety thermostat
- First fix kit supplied as standard
- Compatible with smart home controls
- Return temperature limitation through control of heating  $\Delta T$
- Weather compensation functionality (sensor required)
- Servicing and parts replacement from front
- Integrated apartment quick-fill device
- Isolation & drain valves fitted as standard
- Labelled water connections
- Underfloor or radiator temperature set-points
- PWM controlled A-rated modulating heating pump
- Closed-cell foam insulation cover
- Prepayment cut off
- Optional flushing bypass valve available
- Optional top entry pipe kits available
- Optional DHW recirculation available

**5** 5 Year Warranty\*

**WRAS** WRAS Approved

**BESA** BESA Registered

# Specification

## Primary Circuit (district)

Maximum operating pressure	bar	16
Maximum supply temperature	°C	85
Min/max differential pressure	bar	0.5/4

## Domestic Hot Water (apartment)

Nominal heat exchanger capacity	kW	90
Hot water set-point	°C	40-60
Maximum cold feed supply pressure	bar	10

## Heating (apartment)

Nominal heat exchanger capacity	kW	21
Heating water set-point (underfloor)	°C	30-45
Heating water set-point (radiators)	°C	45-80
Maximum operating pressure	bar	2.5
Safety valve setting	bar	3
Circulating pump		Wilo Para 8-75
Expansion vessel volume	litres	10
Heating control (room thermostat)		Volt free

## General

Dimensions (HxWxD)	mm	600x500x312
Water connections	mm	18/22
Weight (HIU)	kg	24
Weight (first fix kit)	kg	4

## Electrical

Mains supply		230-1-50
Power consumption	W	85
Protection		IP44

## Connections

District inlet (A)	BSP	G ¾"
District return (B)	BSP	G ¾"
Heating flow (C)	BSP	G ¾"
Heating return (D)	BSP	G ¾"
Domestic hot water outlet (E)	BSP	G ¾"
Mains cold water inlet (F)	BSP	G ¾"
Domestic cold water outlet (G)	BSP	G ¾"
Pressure relief valve drain (H)	BSP	G ½"

# Features in Detail

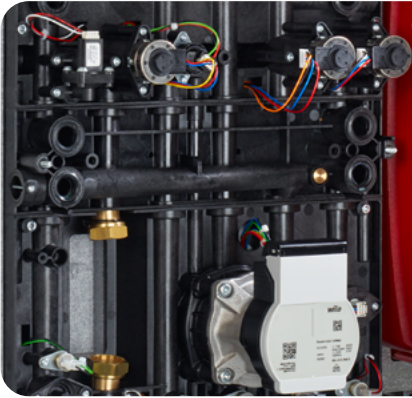

## Unique HydraBlok® back plate

Most other heat interface units available on the market are often a myriad of metal pipework and brass fittings. With this type of HIU every union is a potential source of a water leak, as the unions often loosen during transportation from the factory to the point of use.

The MTA has little potential for leaks as it is not fitted with metal pipework and brass fittings. Everything is built upon a unique HydraBlok® backplate which contains all waterway channels moulded within a composite chassis.

## Return temperature limitation

To ensure the heat network operates at maximum efficiency, the MTA will modulate the rate of water flow provided by the internal apartment heating circuit pump to match the heat load of the apartment at any one time. This maintains the designed heating circuit  $\Delta T$  and limits the temperature of the water returning to the primary circuit.



# Q MAX

## Primary flow rate limitation

The MTA can limit the primary flow rate in both DHW and heating mode, independently of each other.

Limiting the maximum flow rate that the HIU can take from the primary system, during space heating production, guarantees the design flow rate used to calculate system demand, is not exceeded.

## Advanced pump control

The MTA features 24 hour pump exercising - if the heating circuit has not been used for 24 hours, the MTA will run the pump (and open the heating regulation valve) for 10 seconds, ensuring debris cannot build up in the pump bearings.

The MTA also features a low pressure cut out. If the heating circuit pressure falls below 0.4bar, the pump will stop running. The unit will continue to produce DHW.



## Keep warm configurability

The MTA's keep warm function can be on, off or timed (24/7 calendar). The keep warm temperature and hysteresis range are also configurable.

# Features in Detail

## Adjustable heating temperature

Two ranges of apartment heating circuit temperature setpoints can be chosen. For underfloor heating, the setpoint range is between 30°C and 45°C, and for radiators, it is between 45°C and 80°C. If the project is fitted with underfloor heating, then provided that the underfloor heating setpoint parameters are chosen during the set up of the heat interface unit, any accidental increase of the heating circuit water temperature setpoint will not damage any delicate floor material/covering.

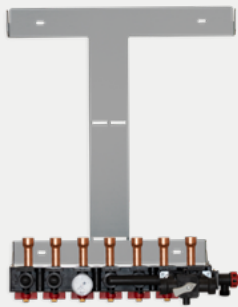
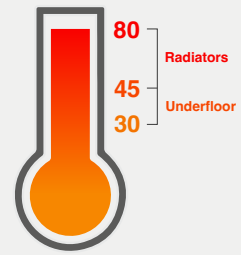

## First fix kit supplied as standard

Supplied with every MTA is a first fix kit complete with a water connection block and isolation valves at the base. Each isolation valve has an integral drain to ensure that every part of the heat interface unit can be released of water should it be needed.

When ready to be installed, the heat interface unit is quickly and easily attached to the first fix kit and secured with three machine screws to ensure a watertight seal. The flat-faced water connections at the base of the unit can be rotated to point either upwards or downwards, depending on the installer's pipework orientation.

## Integral quick-fill device

Contained within the MTA is an easily operated WRAS approved apartment heating circuit filling device. The device allows the filling of the apartment from the mains cold water supply that enters the heat interface unit, therefore there is no need to install a traditional filling loop beneath the appliance. The inhibitor levels should be maintained within the apartment circuit as deemed necessary by the installer.



## Closed-cell foam insulation

Installed behind the robust white powder-coated steel outer case of the MTA is a closed-cell foam cover that insulates the heat exchangers and other integral parts. This maximises heat network efficiency and prevents heat build-up in surrounding areas which can be problematic to the designer. Only the optional heat meter and the head of the apartment heating system circulating pump are left exposed to prevent overheating.

The outer case is made with a swing door at the base, which allows the integral heat meter to be manually read and provides easy access to the heating system integral fill device. The installer or tenant can also top up the water pressure, as necessary, to ensure the continued operation of the appliance.

# Features in Detail

## Easy parts replacement

If any components should need replacing, all vital parts are easily accessible from the front of the MTA, thus little clearance is required at the sides of the heat interface unit.

In under a few minutes, the unit can be isolated, drained, and a stepper motor, pump head, expansion vessel or even heat exchanger can be removed and changed if necessary.



## Advanced diagnostics

The control panel within the MTA provides a friendly, intuitive user experience.

In addition, it provides an extremely high level of real time data, offering an overview of the current conditions within the network, HIU and apartment.



- 1 Primary flow temperature
- 2 DHW temperature
- 3 MCW temperature
- 4 Primary return temperature
- 5 District modulating valve stepper motor position (0 to 250)
- 6 DHW flow rate
- 7 DHW regulation valve stepper motor position (0 or 250)
- 8 Heating regulation valve stepper motor position (0 or 250)
- 9 Heating flow temperature
- 10 Heating pressure
- 11 Heating flow rate
- 12 Heating return temperature
- 13 Primary flow rate

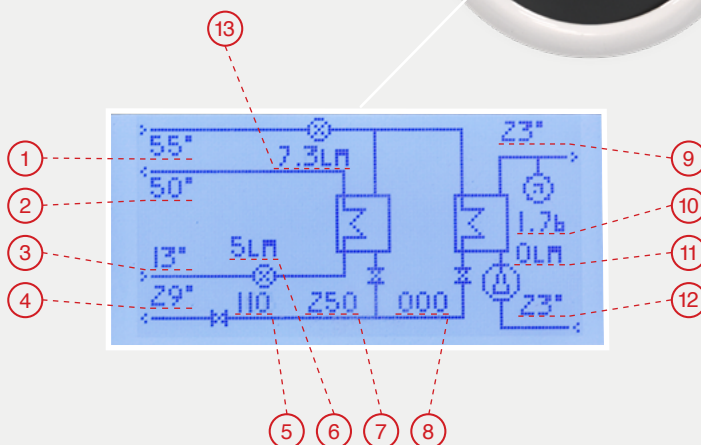

## Breakdown service

Modutherm offer exceptional after-care for the MTA heat interface units, through a combination of directly employed and sub-contract engineers, both of which carry extensive spare parts.

# Features in Detail

## Warranty

The MTA HIU is covered as standard by a manufacturer 5 year complete parts and a 2 year labour warranty that commences from the date of commissioning of the appliance by Modutherm. Commissioning must be undertaken by Modutherm or a trained installer for this warranty to be applicable.



## DHW Recirculation

For projects requiring instant hot water with long pipe runs, it is possible for a domestic hot water recirculation circuit to be fitted to the MTA. The MTA powers the DHW pump (not supplied) via the External 230V and monitors the return temperature through a wired pipe sensor (optional extra) fitted to the DHW return.

# Connectivity

## Modbus remote communication

The MTA has Modbus remote read/write communication built in. Each HIU can be remotely interrogated to capture temperatures and operating parameters, many of which can be remotely set and configured.

This allows the network operator to monitor the performance of each HIU via the buildings BMS system. Data can be gathered over time, giving real insight into the performance and operation of the heat network.

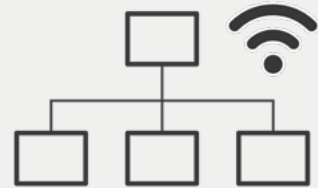

## ModuHub (optional extra)

ModuHub enables remote monitoring and control of the MTA heat interface unit, enabling network operators to continuously optimise their heat networks, ensuring reduced running costs whilst improving service quality for the end users.

It can also be used to detect and alert maintenance providers to possible faults, allowing faults to be resolved remotely and considerably reducing the number of planned service/maintenance visits to site.

ModuHub creates an open protocol wireless billing network, removing the requirement for an Mbus network. Through our open API, meter reads can be retrieved by billing providers using LoRa Communication. Moduhub can be utilised for both prepayment or credit billing.

The ModuHub box is small and compact, allowing it to fit within the MTA casing.

# Extras



## Optional integral heat meter

An optional factory-fitted M-Bus heat meter can be installed within the MTA, allowing remote monitoring and billing services. An alternative Modbus heat meter allows for two-way communication, and for the status of the unit to be seen at the billing provider.

If Modutherm doesn't supply a heat meter, then a spool piece is installed within the appliance where the heat meter would be sited.

## Optional pipe kits

For the MTA optional insulated pipe kits are available, which take the connection made by the installer from the base of the HIU to the top of the appliance. The pipes, which are provided complete with closed-cell low U-value [ $\leq 0.034 \text{ W/(m}\cdot\text{K)}$ ] foamed nitrile rubber insulation, will pass in between the back of the unit and the first fix kit and terminate with a flat face and  $\frac{3}{4}$ " BSP nut with fibre washer.



## Optional flushing bypass valve

The Modutherm flushing bypass valve simplifies primary circuit flushing and cleaning while protecting the MTA's heat exchangers and components.

The bypass valve is a full bore valve that's fully insulated. To prevent unintended use of the bypass, the connectors can be removed and the handles can be locked in position.

The handles allow the position of the valve to be visually identified, while also featuring integrated binder points for differential pressure readings.

# Components

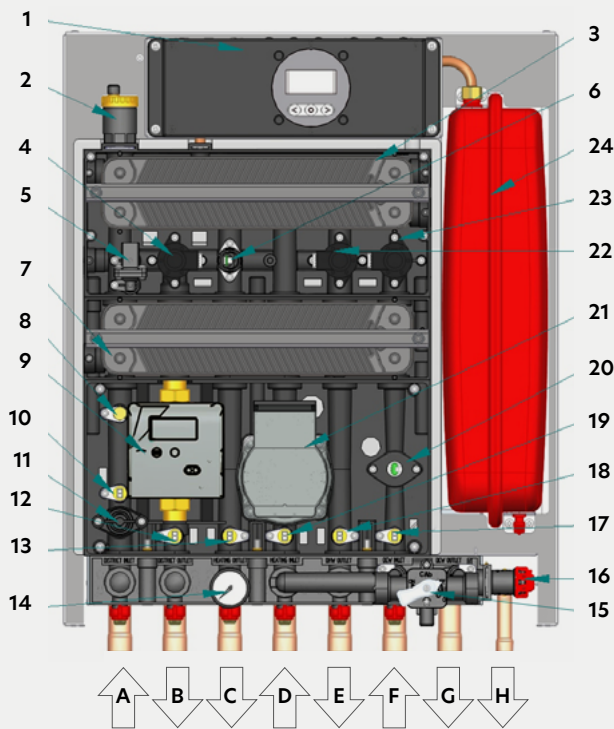

- 1 Control Box
- 2 Automatic Air Vent
- 3 Heat Exchanger, Heating
- 4 District Modulating Valve
- 5 Differential Pressure Sensor
- 6 Pressure Sensor
- 7 Heat Exchanger, Domestic Hot Water
- 8 Heat Meter Sensor
- 9 Heat Meter
- 10 District Inlet Sensor
- 11 District Filter
- 12 District Return Sensor
- 13 Heating Flow Sensor
- 14 Heating Pressure Gauge
- 15 Filling Device
- 16 3bar Pressure Relief Valve
- 17 Domestic Cold Water Sensor
- 18 Domestic Hot Water Sensor
- 19 Heating Return Sensor
- 20 Domestic Hot Water Flow Switch
- 21 Pump
- 22 Heating Regulation Valve
- 23 Domestic Hot Water Regulation Valve
- 24 Expansion Tank

- |                   |                               |
|-------------------|-------------------------------|
| A District Inlet  | E Domestic Hot Water Outlet   |
| B District Return | F Mains Cold Water Inlet      |
| C Heating Flow    | G Domestic Cold Water Outlet  |
| D Heating Return  | H Pressure Relief Valve Drain |

# Schematic

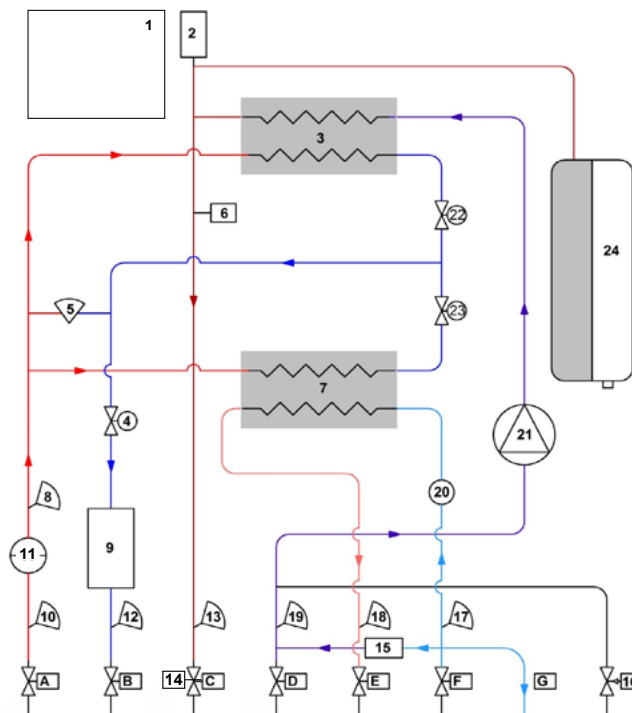

# Performance Data

## Domestic hot water data at 50kPa district circuit pressure differential

PRIMARY FLOW TEMP °C	DHW TEMPS °C	DHW OUTPUT (max) kW	DHW FLOW RATE l/m	DHW PRESSURE DROP kPa	PRIMARY FLOW RATE l/min	PRIMARY PRESSURE DROP kPa	PRIMARY RETURN TEMP °C
60	10/50	47.55	17.06	27.69	22.35	50	28.93
65	10/50	58.42	20.96	41.60	22.35	50	26.73
70	10/50	68.33	24.52	54.92	22.35	50	25.12
75	10/50	77.65	27.86	73.58	22.35	50	23.85
80	10/50	86.56	31.06	92.30	22.35	50	22.82

Note: CIBSE CP1 2020 recommends DHW supply temperature of 50°C. For performance data at other DHW temperatures, please contact Modutherm.

## Heating data (underfloor) at 60kPa heating circuit residual pump pressure

PRIMARY FLOW TEMP °C	HEATING TEMPS °C	HEATING OUTPUT (max) kW	HEATING FLOW RATE l/m	HEATING PRESSURE DROP kPa	PRIMARY FLOW RATE l/min	PRIMARY PRESSURE DROP kPa	PRIMARY RETURN TEMP °C
60	45/35	10.5	15.07	60	6.42	3.00	36.34
	45/40	5.25	15.07	60	3.83	1.05	40.19
	40/30	10.5	15.07	60	5.24	2.02	30.92
	40/35	5.25	15.07	60	3.06	0.72	35.10
65	45/35	10.5	15.07	60	5.23	2.01	35.83
	45/40	5.25	15.07	60	3.06	0.72	40.09
	40/30	10.5	15.07	60	4.44	1.44	30.60
	40/35	5.25	15.07	60	2.55	0.50	35.05
70	45/35	10.5	15.07	60	4.43	1.44	35.54
	45/40	5.25	15.07	60	2.55	0.50	40.04
	40/30	10.5	15.07	60	3.87	1.06	30.40
	40/35	5.25	15.07	60	2.19	0.35	35.03
75	45/35	10.5	15.07	60	3.87	1.06	35.35
	45/40	5.25	15.07	60	2.19	0.35	40.03
	40/30	10.5	15.07	60	3.43	0.88	30.27
	40/35	5.25	15.07	60	1.92	0.26	35.02
80	45/35	10.5	15.07	60	3.43	0.88	35.24
	45/40	5.25	15.07	60	1.92	0.26	40.02
	40/30	10.5	15.07	60	3.09	0.73	30.19
	40/35	5.25	15.07	60	1.71	0.23	35.01

## Heating data (radiators) at 60kPa heating circuit residual pump pressure

PRIMARY FLOW TEMP °C	HEATING TEMPS °C	HEATING OUTPUT (max) kW	HEATING FLOW RATE l/m	HEATING PRESSURE DROP kPa	PRIMARY FLOW RATE l/min	PRIMARY PRESSURE DROP kPa	PRIMARY RETURN TEMP °C
60	55/35	21	15.07	60	21.52	34.36	45.90
	55/45	10.5	15.07	60	13.22	12.89	48.54
	50/30	21	15.07	60	13.62	13.64	37.68
	50/40	10.5	15.07	60	8.45	5.19	42.04
65	55/35	21	15.07	60	13.40	13.23	42.30
	55/45	10.5	15.07	60	8.39	5.11	46.90
	50/30	21	15.07	60	10.36	7.94	35.59
	50/40	10.5	15.07	60	6.40	2.98	41.23
70	55/35	21	15.07	60	10.25	7.76	40.25
	55/45	10.5	15.07	60	6.38	2.95	46.14
	50/30	21	15.07	60	8.54	5.32	34.20
	50/40	10.5	15.07	60	5.22	2.01	40.76
75	55/35	21	15.07	60	8.48	5.23	38.92
	55/45	10.5	15.07	60	5.21	2.00	45.70
	50/30	21	15.07	60	7.34	3.91	33.22
	50/40	10.5	15.07	60	4.43	1.35	40.49
80	55/35	21	15.07	60	7.30	3.87	37.98
	55/45	10.5	15.07	60	4.43	1.43	45.44
	50/30	21	15.07	60	6.47	3.05	32.51
	50/40	10.5	15.07	60	3.86	1.06	40.31

# DHW Performance Graphs

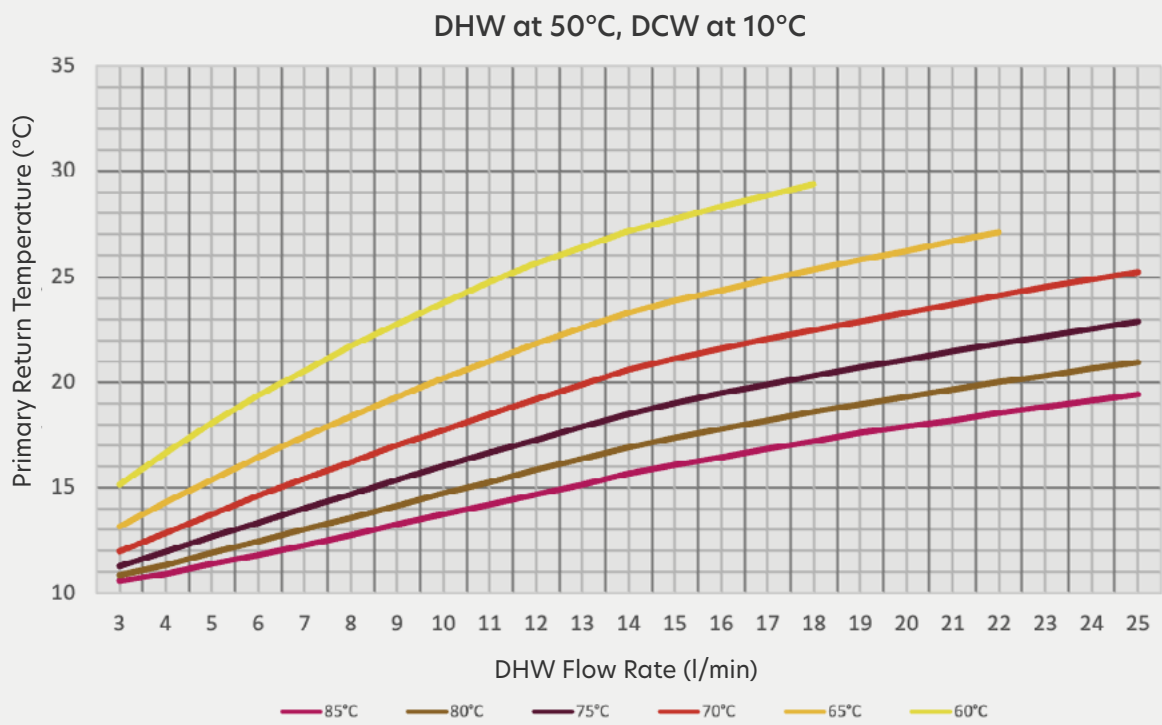
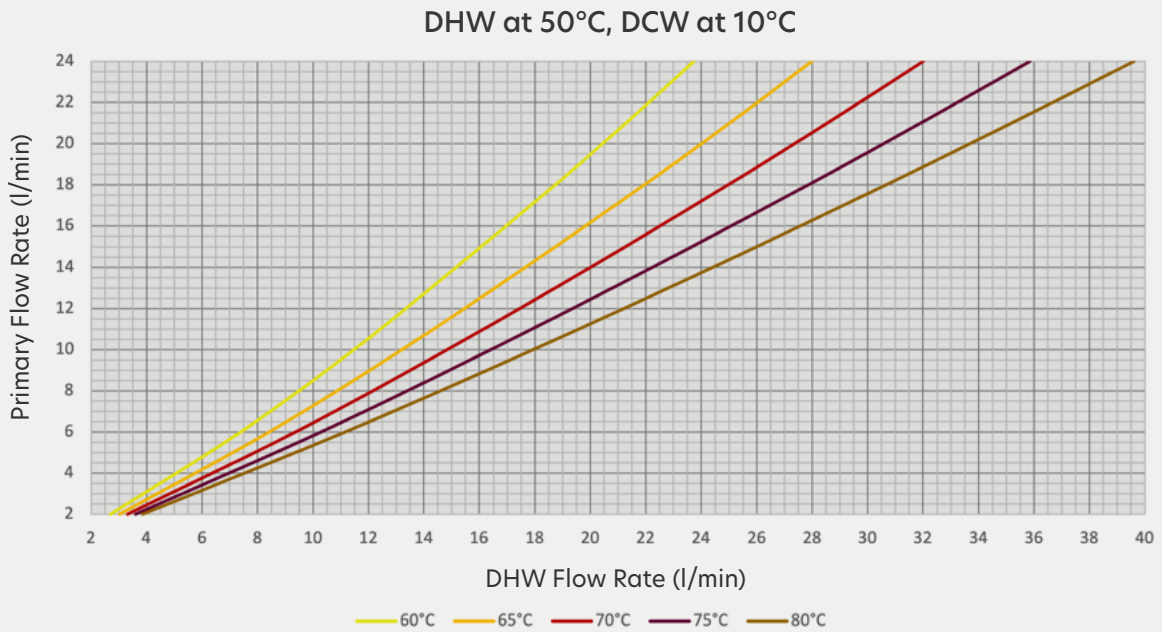

**Modutherm Limited**  
**Unit 4 Genesis**  
**Endeavour Drive**  
**Basildon, SS14 3WF**

**modutherm.co.uk**  
Tel: 0345 521 5666  
modutherm@modularhg.co.uk

Your local contact is:

