



# AW290

35kW

Commercial reversible air source heat pump  
Heating & cooling



 R290

The R290 refrigerant logo, consisting of a green leaf icon followed by the text "R290" in a bold, green, sans-serif font.

OUTPUT (kW)

35 - 560

# AW290

The AW290 is a high-performance, high temperature air source heat pump designed to meet heating, cooling, and domestic hot water demands in commercial applications, including apartment buildings, hotels, and schools. The AW290 utilises natural R290 refrigerant for exceptional energy efficiency and a reduced environmental impact.

Up to 16 units can be arranged in cascade to provide capacity up to 560kW, making them ideal for commercial installations.

Featuring the latest inverter technology, the AW290 ensures optimal system efficiency by automatically adjusting output to match heating demand. This guarantees stable operation even in colder conditions, maximising performance while minimising energy consumption.



5

5 Year Compressor Warranty\*

2

2 Year Parts Warranty\*

## EVI powered

The AW290 units are equipped with EVI technology, enabling high energy efficiency and stable performance. With inverter and EVI technology, the series reaches A+++ (35/55°C) energy efficiency and COP is up to 4.2.

## R290 refrigerant

The units use R290 refrigerant, a natural and environmentally friendly alternative with a low global warming potential. R290 has been widely adopted in modern heat pump technology due to its excellent thermodynamic properties, delivering high efficiency and reliable performance in air-to-water heat pump applications.

## R290 leak sensor

The integrated R290 leak sensor ensures safe operation with high sensitivity and a rapid 5-second response time. Designed for long-term reliability, it requires no calibration or maintenance and has an impressive 15-year lifespan, providing continuous protection and peace of mind.

## Refrigerant/water separator

The AW290 heat pump includes an automatic refrigerant/water separator, ensuring safe operation by preventing any gas from escaping into indoor spaces. This built-in safety feature helps maintain system efficiency and protects occupants from potential exposure.

- Monobloc design for easy installation
- Electronic expansion valve control for precise superheat regulation
- Modbus/BACnet communication
- Self-adjusting EEV control
- Inbuilt pump

Energy efficiency	A+++ (35/55°C)
COP (A7/W35)	4.20
SCOP (LWT35)	4.59
Heating output	35kW
Max. flow temperature	85°C
Working range (min/max)	-25 / 43°C
Power supply	415V
Sound power level	63.4 dB(A)

# Dimensions

Dimensions: mm

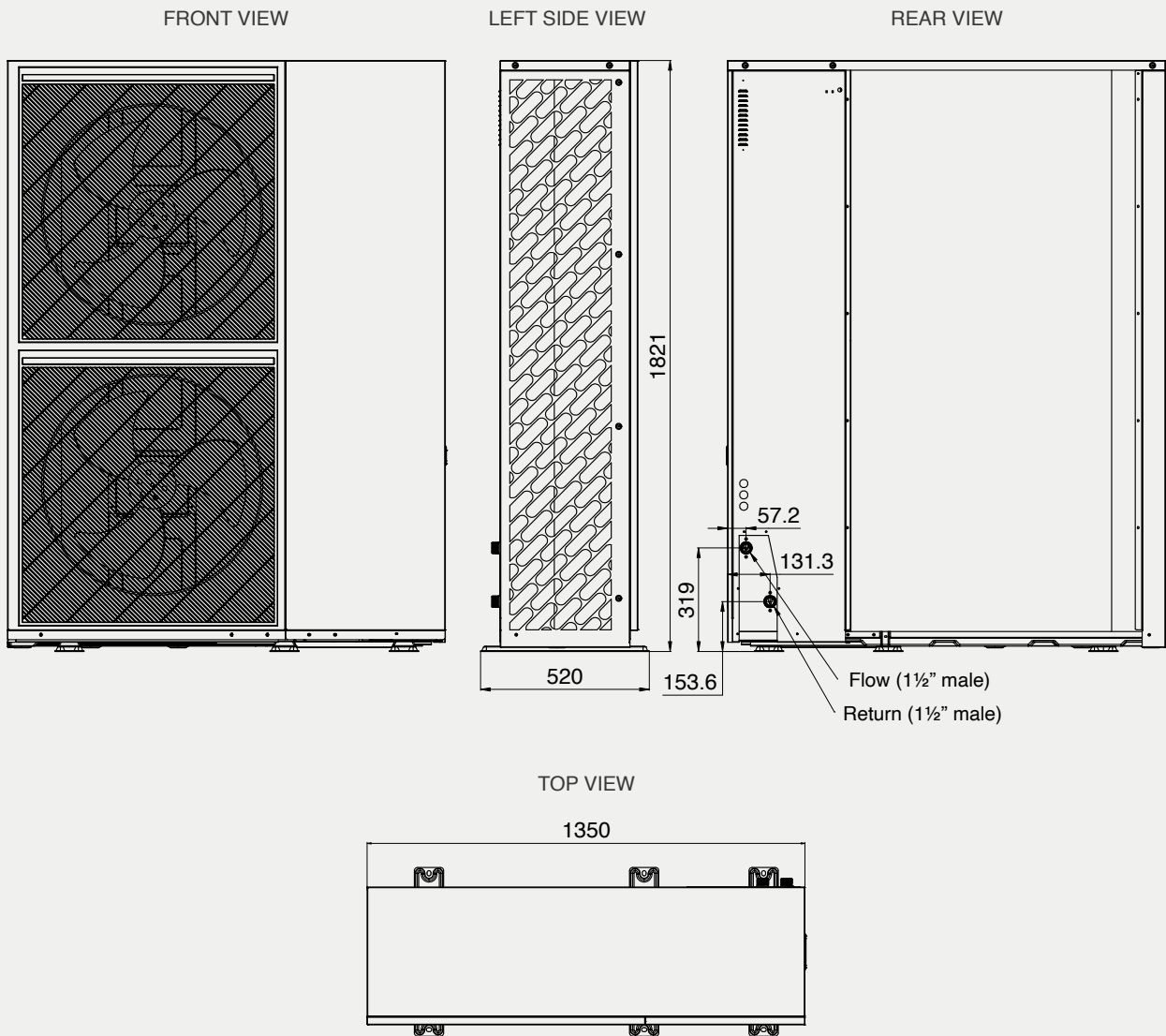

Clearances (mm)	35kW
Front	3000
Rear	1000
Left	1000
Right	1000
Top	1000

# Performance data

35kW

Power supply	V / Ph / H		380-415 / 3 / 50
IP rating			IPX4
<b>Performance</b>			
Heating capacity at 35°C <sup>1</sup>	Capacity	kW	35.0
	Rated input	kW	8.33
	COP		4.20
Heating capacity at 45°C <sup>2</sup>	Capacity	kW	35.0
	Rated input	kW	10.57
	COP		3.31
Heating capacity at 55°C <sup>3</sup>	Capacity	kW	35.0
	Rated input	kW	12.92
	COP		2.71
Cooling capacity <sup>4</sup>	Capacity	kW	28.0
	Rated input	kW	6.65
	EER		4.21
Cooling capacity <sup>5</sup>	Capacity	kW	24.0
	Rated input	kW	8.30
	EER		2.89
Energy efficiency class			A+++
SCOP (Seasonal Coefficient of Performance)	LWT at 35°C / 55°C		4.59 / 3.83
SEER (Seasonal Energy Efficiency Ratio)	LWT at 7°C / 18°C		5.49 / 7.17
Operating temperature (min/max)	Cooling	°C	-5 / 43
	Heating	°C	-25 / 35
	DHW	°C	-25 / 43
MOP (Maximum Overcurrent Protection)	A		30
MCA (Maximum Circuit Amps)	A		28
GWP (Global Warming Potential)			3
Equivalent CO <sub>2</sub>	Ton		0.010
Sound power level <sup>6</sup>	dB		63.4
Sound pressure level @ 1 metre (A7/W55)	dB		47.4
<b>Components</b>			
Fan	Motor type	Brushless DC motor	
	Number of fans	2	
	Speed	rpm	750
Refrigerant	Type	R290	
	Charge	kg	3
	System pressure (min/max)	MPa	0.3 / 3.5
Compressor	Type	EVI Scroll DC Compressor	
	Quantity	1	
Throttle type	Electronic expansion valve		
Water side heat exchanger	Plate heat exchanger		
<b>Hydraulic</b>			
Water pressure drop	kPa		27
Rated water flow	m <sup>3</sup> /h		6.02
Flow/return connections	1½" M		
<b>Dimensions</b>			
Dimensions (LxDxH)	Net	mm	1350 × 520 × 1821
	Packaging	mm	1415 × 535 × 2016
Weight	Net	kg	310
	Gross	kg	331

# Operating conditions

External temperature °C	Flow temperature °C	Heat output kW	COP	Input power kW	Input current A
<b>-15</b>	35	32.2	1.91	16.9	22.3
	45	31.2	1.87	16.7	22.1
	55	30.9	1.84	16.8	22.5
	60	25.9	1.55	16.7	22.1
	65	20.4	1.23	16.6	22.1
	75	18.6	1.13	16.4	22.0
<b>-10</b>	35	34.0	2.02	16.8	22.3
	45	33.8	2.01	16.8	22.5
	55	33.2	1.99	16.7	22.1
	65	27.3	1.65	16.5	21.9
	70	25.3	1.53	16.5	22.0
	75	21.3	1.29	16.5	21.8
<b>-7</b>	80	19.3	1.15	16.8	22.1
	35	34.1	2.21	15.4	21.3
	45	33.9	2.19	15.5	21.3
	55	33.5	2.13	15.7	21.7
	65	28.0	1.84	15.2	21.0
	70	25.9	1.71	15.1	20.8
<b>-5</b>	75	21.8	1.43	15.3	21.0
	80	19.5	1.24	15.7	21.7
	35	34.1	2.43	14.0	19.5
	45	34.1	2.31	14.7	20.3
	55	34.0	2.27	15.0	20.6
	65	28.2	1.91	14.8	20.3
<b>-2</b>	70	26.1	1.75	14.9	20.5
	75	22.0	1.49	14.8	20.3
	80	19.2	1.25	15.4	21.2
	35	34.2	2.77	12.3	17.1
	45	34.1	2.45	13.9	19.3
	55	34.0	2.29	14.9	20.4
<b>0</b>	65	29.2	2.02	14.5	20.1
	70	26.9	1.91	14.1	19.4
	75	22.8	1.51	15.1	20.8
	80	19.1	1.27	15.0	20.7
	35	34.3	3.01	11.4	16.1
	45	34.1	2.57	13.3	18.7
<b>7</b>	55	34.1	2.31	14.8	20.3
	65	30.2	2.03	14.9	20.5
	70	27.8	1.93	14.4	20.1
	75	23.5	1.53	15.3	21.2
	80	20.1	1.29	15.6	21.5
	35	35.0	4.20	8.3	12.1
<b>7</b>	45	35.0	3.31	10.6	14.5
	55	35.0	2.71	12.9	18.3
	65	30.6	2.28	13.4	19.1
	70	28.0	2.07	13.5	19.2
	75	24.2	1.61	15.0	20.7
	80	20.0	1.31	15.3	20.1

# Schematic

Simplified diagram for illustration only - safety devices may have been omitted for clarity.  
For additional schematics, refer to the installation guide.

Symbol	Description	Symbol	Description
	Isolating valve		Strainer
	Check valve		Temp sensor
	Circulation pump		3-way valve
	Pressure gauge		Degasser
			Safety valve

## Heating & DHW with Plate Heat Exchanger

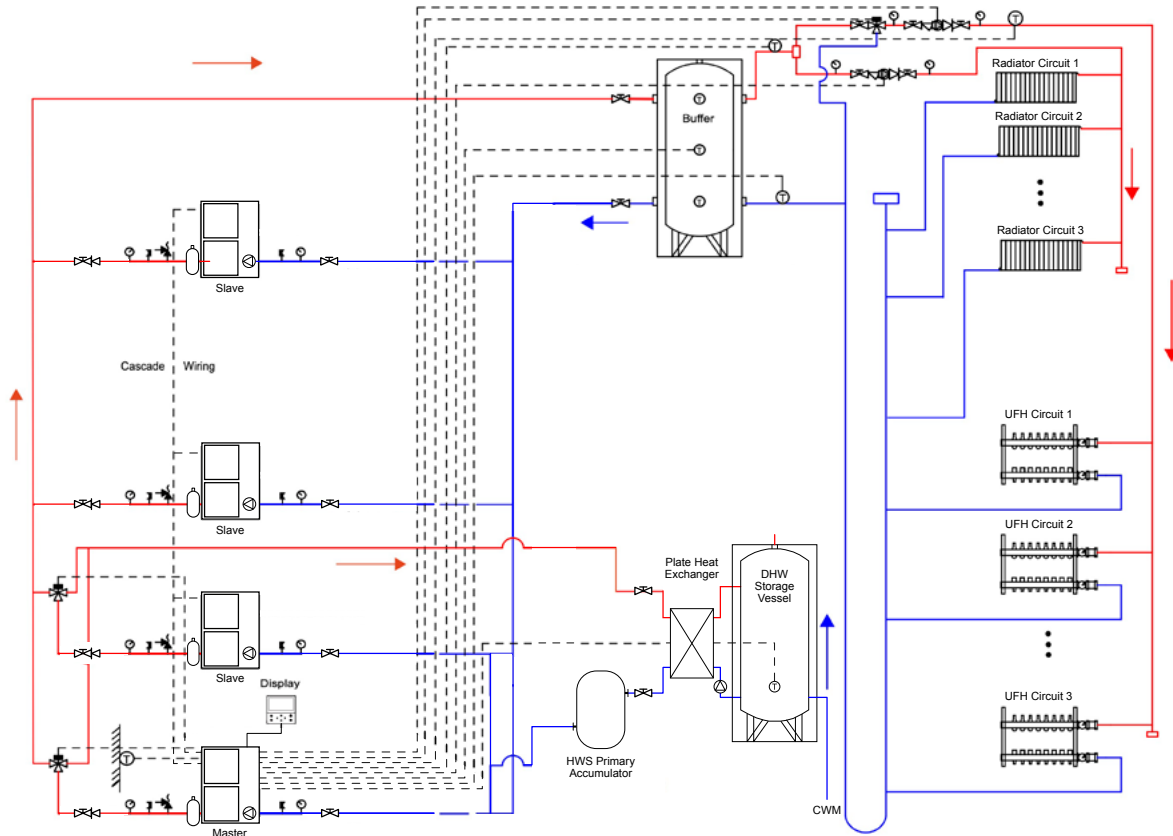

## DHW only

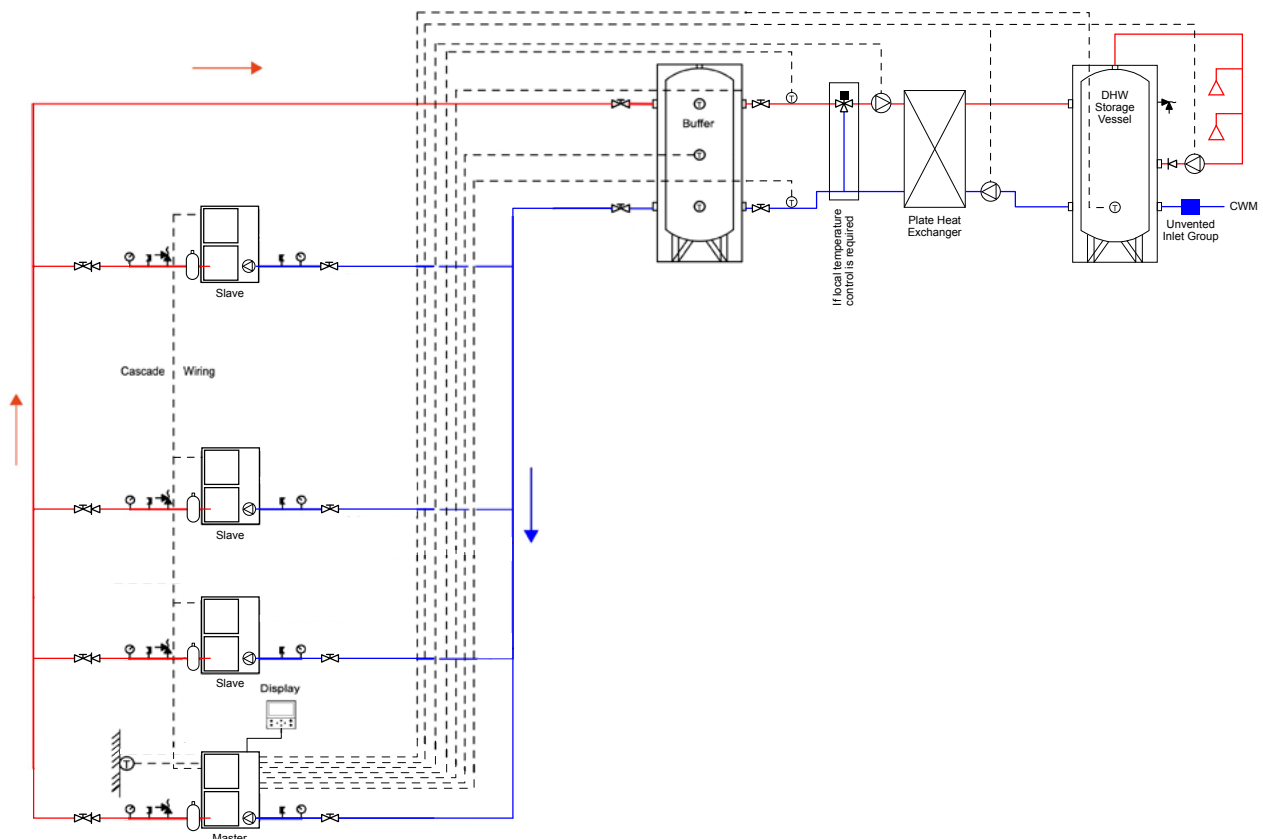

# Buffer vessels

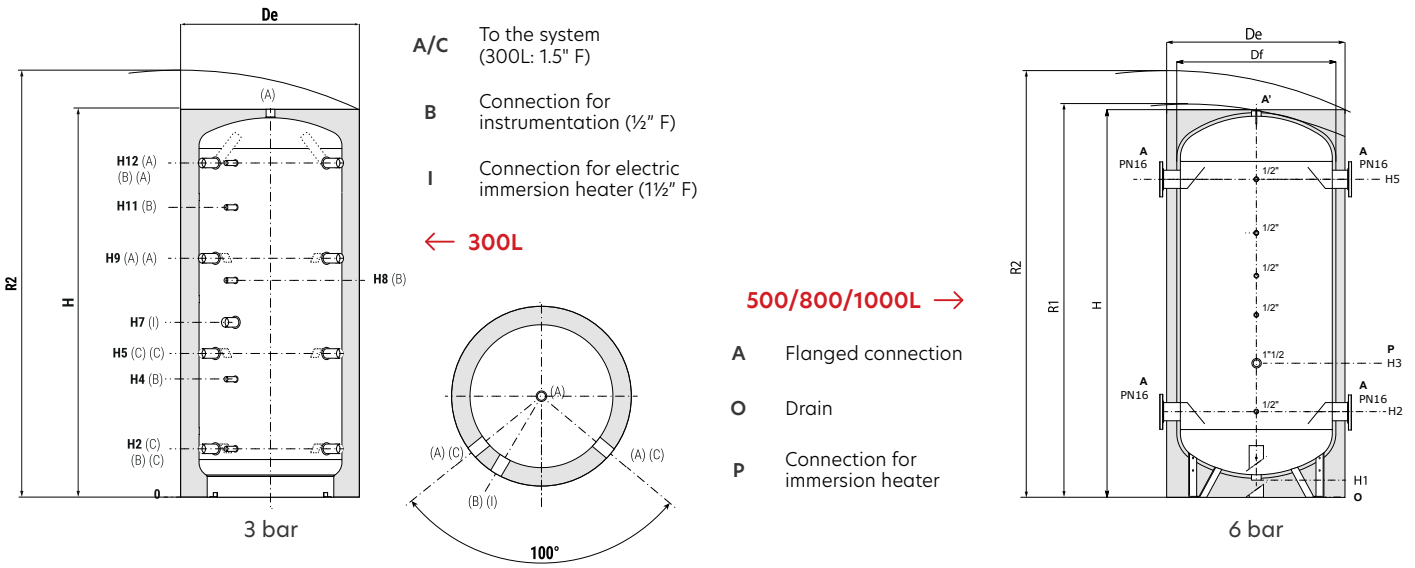

Model	Volume litres	Weight kg	De (VB)	H	R2	H2	H4	H5 mm	H7	H8	H9	H11	H12
300	279	51	650	1340	1495	232	444	514	590	725	796	885	1078

Model	Volume litres	Weight kg	Df	De	H	R1	R2	H1	H2	H3	H4	H5	O	A'	A
500	478	77	690	910	1805	1940	2030	130	405	705	1205	1455	1 1/4"	1 1/4"	DN80 PN16
800	758	105	750	1010	2113	2240	2330	120	415	815	1415	1715	1 1/4"	1 1/4"	DN80 PN16
1000	987	141	890	1110	2115	2300	2400	105	425	825	1425	1725	1 1/2"	1 1/2"	DN100 PN16

# Controller

The AW290 comes with an advanced controller designed for seamless integration and optimal system performance. Offering precise control and monitoring, it enhances efficiency, flexibility, and ease of use across various applications.

- Cascade control for up to 16 heat pumps
- 0-10V control for seamless system integration
- Three-zone control with diverter valve management
- Modbus/BACnet compatibility for BMS integration
- Weather compensation for enhanced efficiency
- Quiet mode for reduced noise operation
- Real-time energy data: capacity, consumption, and COP
- Weekly scheduling for customised operation
- Frost protection to prevent system damage
- SG ready for smart grid compatibility
- Power-off memory to retain settings after shutdown

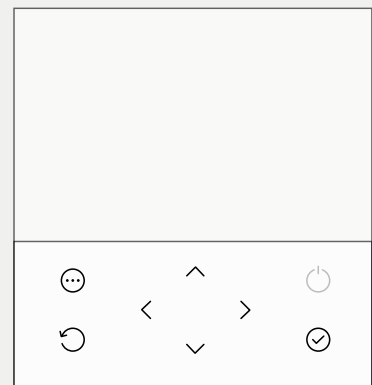

**Modutherm Limited**  
**Unit 4 Genesis**  
**Endeavour Drive**  
**Basildon, SS14 3WF**

**modutherm.co.uk**  
Tel: 0345 521 5666  
modutherm@modularhg.co.uk