



# AW290

100kW

Commercial reversible air source heat pump  
Heating & cooling



OUTPUT (kW)

100 - 1600

# AW290 100kW

The AW290 is a high-performance, high temperature air source heat pump designed to meet heating, cooling, and domestic hot water demands in commercial applications, including apartment buildings, hotels, and schools. The AW290 utilises natural R290 refrigerant for exceptional energy efficiency and a reduced environmental impact.

Up to 16 units can be arranged in cascade to provide capacity up to 1600kW, making them ideal for commercial installations.

Featuring the latest inverter technology, the AW290 ensures optimal system efficiency by automatically adjusting output to match heating demand. This guarantees stable operation even in colder conditions, maximising performance while minimising energy consumption.



5

5 Year Compressor Warranty\*

2

2 Year Parts Warranty\*

## EVI powered

The AW290 units are equipped with EVI technology, enabling high energy efficiency and stable performance. With inverter and EVI technology, the series reaches A+++ (35/55°C) energy efficiency and COP is up to 4.3.

## R290 refrigerant

The units use R290 refrigerant, a natural and environmentally friendly alternative with a low global warming potential. R290 has been widely adopted in modern heat pump technology due to its excellent thermodynamic properties, delivering high efficiency and reliable performance in air-to-water heat pump applications.

## R290 leak sensor

The integrated R290 leak sensor ensures safe operation with high sensitivity and a rapid 5-second response time. Designed for long-term reliability, it requires no calibration or maintenance and has an impressive 15-year lifespan, providing continuous protection and peace of mind.

## Refrigerant/water separator

The AW290 heat pump includes an automatic refrigerant/water separator, ensuring safe operation by preventing any gas from escaping into indoor spaces. This built-in safety feature helps maintain system efficiency and protects occupants from potential exposure.

- Monobloc design for easy installation
- Electronic expansion valve control for precise superheat regulation
- Modbus/BACnet communication
- Self-adjusting EEV control

Energy efficiency	A+++ (35/55°C)
COP (A7/W35)	4.30
SCOP (LWT35)	4.72
Heating output	100kW
Max. flow temperature	85°C
Working range (min/max)	-30 / 48°C
Power supply	415V
Sound power level	85 dB(A)

# Dimensions

100kW

Dimensions: mm

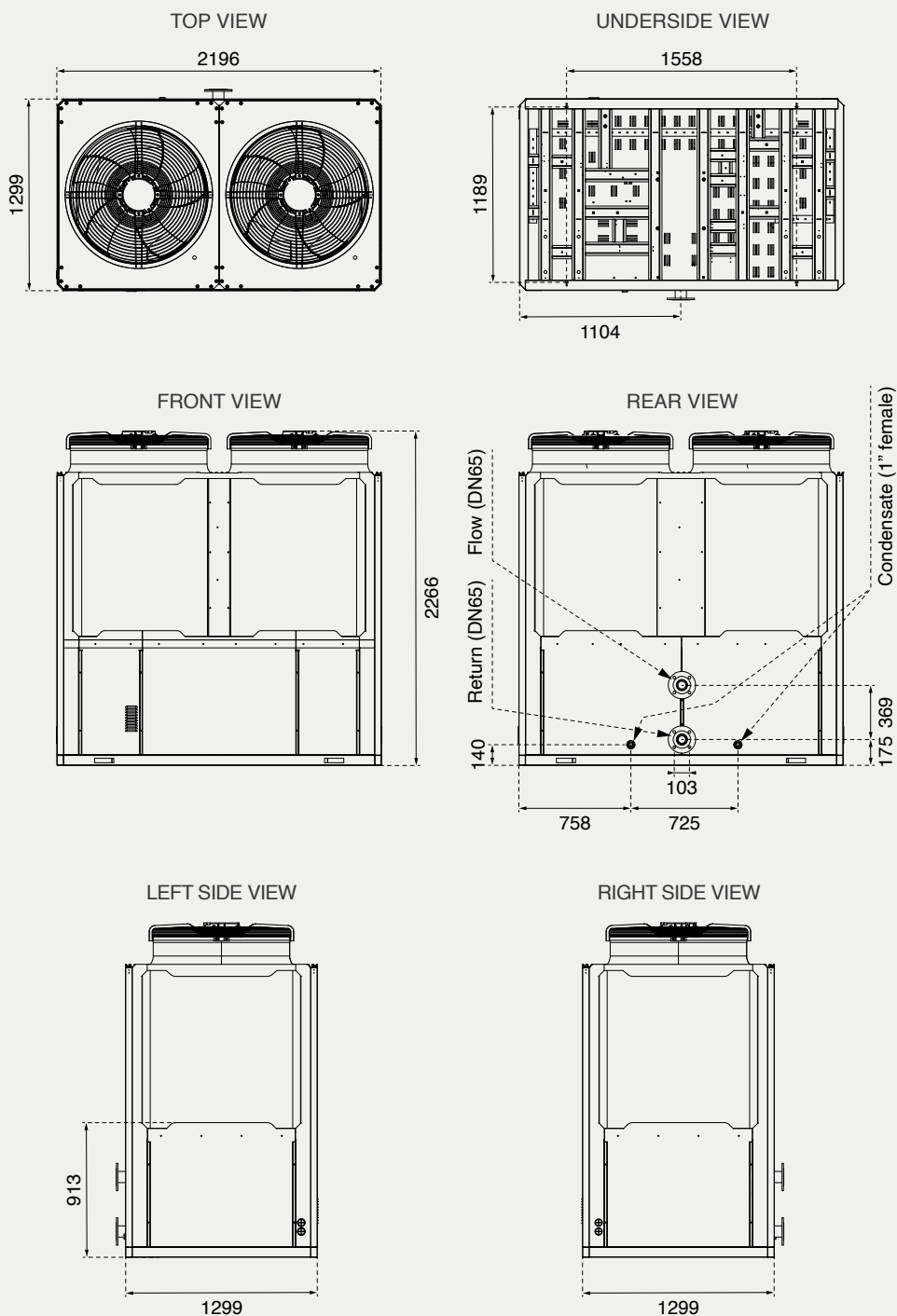

Service Clearances (mm)

Front	1000
Rear	1000
Left	1000
Right	1000
Top	3000

For safety (ATEX) and vigilance zone clearances, please refer to the Engineering Data Book and Installation Guide.

# Performance data

				100kW
<b>Power supply</b>		V / Ph / H		380-415 / 3 / 50
<b>IP rating</b>				IPX4
<b>Performance</b>				
<b>Heating capacity at 35°C<sup>1</sup></b>	<b>Capacity</b>	kW	100.0	
	<b>Rated input</b>	kW	23.26	
	<b>COP</b>		4.30	
<b>Heating capacity at 45°C<sup>2</sup></b>	<b>Capacity</b>	kW	100.0	
	<b>Rated input</b>	kW	27.40	
	<b>COP</b>		3.65	
<b>Heating capacity at 55°C<sup>3</sup></b>	<b>Capacity</b>	kW	100.0	
	<b>Rated input</b>	kW	31.95	
	<b>COP</b>		3.13	
<b>Cooling capacity<sup>4</sup></b>	<b>Capacity</b>	kW	90.00	
	<b>Rated input</b>	kW	21.43	
	<b>EER</b>		4.20	
<b>Cooling capacity<sup>5</sup></b>	<b>Capacity</b>	kW	85.00	
	<b>Rated input</b>	kW	29.31	
	<b>EER</b>		2.90	
<b>Energy efficiency class</b>				A+++
<b>SCOP (Seasonal Coefficient of Performance)</b>	<b>LWT at 35°C / 55°C</b>			4.72 / 3.94
<b>SEER (Seasonal Energy Efficiency Ratio)</b>	<b>LWT at 7°C / 18°C</b>			5.02 / 7.11
<b>Operating temperature (min/max)</b>	<b>Cooling</b>	°C	-10 / 48	
	<b>Heating</b>	°C	-30 / 35	
	<b>DHW</b>	°C	-30 / 43	
<b>Maximum flow temperature</b>		°C	85	
<b>MOP (Maximum Overcurrent Protection)</b>		A	130	
<b>MCA (Maximum Circuit Amps)</b>		A	110	
<b>GWP (Global Warming Potential)</b>				3
<b>Equivalent CO<sub>2</sub></b>		Ton	0.029	
<b>Sound power level (A7/W35) / (A7/W55)</b>	<b>Partial load</b>	dB(A)	71 / 76	
	<b>Full load</b>	dB(A)	85 / 86	
<b>Sound pressure level @ 1 metre (A7/W35) / (A7/W55)</b>	<b>Partial load</b>	dB(A)	53 / 58	
	<b>Full load</b>	dB(A)	67 / 68	
<b>Components</b>				
<b>Fan</b>	<b>Motor type</b>			Brushless DC motor
	<b>Number of fans</b>			2
	<b>Speed</b>	rpm	830	
<b>Refrigerant</b>	<b>Type</b>			R290
	<b>Charge</b>	kg	4.9 (x2)	
	<b>System pressure (min/max)</b>	MPa	0.03 / 3.5	
<b>Compressor</b>	<b>Type</b>			EVI Scroll DC Compressor
	<b>Quantity</b>			2
<b>Throttle type</b>				Electronic expansion valve
<b>Water side heat exchanger</b>				Plate heat exchanger
<b>Hydraulic</b>				
<b>Water pressure drop</b>		kPa	15	
<b>Rated water flow</b>		m <sup>3</sup> /h	17.20	
<b>Flow/return connections</b>				DN65
<b>Dimensions</b>				
<b>Dimensions (LxDxH)</b>	<b>Net</b>	mm	2169 × 1299 × 2266	
	<b>Packaging</b>	mm	2300 × 1450 × 2450	
<b>Weight</b>	<b>Net</b>	kg	830	
	<b>Gross</b>	kg	885	

<sup>4</sup> LWT = Leaving Water Temperature  
EWT = Entering Water Temperature

<sup>1</sup> Outdoor air temperature 7°C DB, 85% R.H ; EWT 30°C, LWT 35°C

<sup>2</sup> Outdoor air temperature 7°C DB, 85% R.H ; EWT 40°C, LWT 45°C

<sup>3</sup> Outdoor air temperature 7°C DB, 85% R.H ; EWT 47°C, LWT 55°C

<sup>4</sup> Outdoor air temperature 35°C DB, 85% R.H ; EWT 23°C, LWT 18°C

<sup>5</sup> Outdoor air temperature 35°C DB, 85% R.H ; EWT 12°C, LWT 7°C

# Operating conditions

External temperature °C	Flow temperature °C	Heat output kW	COP	Input power kW	Input current A
-20	35	73.09	2.15	34.00	53.3
	45	73.02	1.92	38.03	59.7
	55	74.11	1.73	42.84	67.2
	65	72.64	1.51	48.11	75.5
-15	35	80.35	2.34	34.34	53.9
	45	81.27	2.13	38.15	59.9
	55	80.22	1.86	43.13	67.7
	65	80.31	1.64	48.97	76.8
-10	75	80.51	1.49	54.03	84.8
	35	88.96	2.63	33.83	53.1
	45	88.76	2.27	39.10	61.3
	55	88.53	1.97	44.94	70.5
-5	65	88.46	1.72	51.43	80.7
	75	88.38	1.60	55.24	86.7
	35	99.69	2.82	35.35	55.5
	45	99.87	2.48	40.27	63.2
0	55	99.93	2.16	46.26	72.6
	65	99.76	1.83	54.51	85.5
	80	89.24	1.64	54.41	85.4
	35	99.97	3.22	31.05	48.7
7	45	100.05	2.87	34.86	54.7
	55	100.20	2.49	40.24	63.1
	65	99.38	2.14	46.44	72.9
	80	94.26	1.76	53.56	84.0
7	35	100.00	4.30	23.26	36.5
	45	100.00	3.65	27.40	43.0
	55	100.00	3.13	31.95	50.1
	65	99.97	2.61	38.30	60.1
7	80	98.21	1.85	53.09	83.3

## Performance envelope

**85°C**

Ultra-high leaving water temperature

**-30°C**

Extremely low working (air) temperature

- High temperature
- Normal temperature

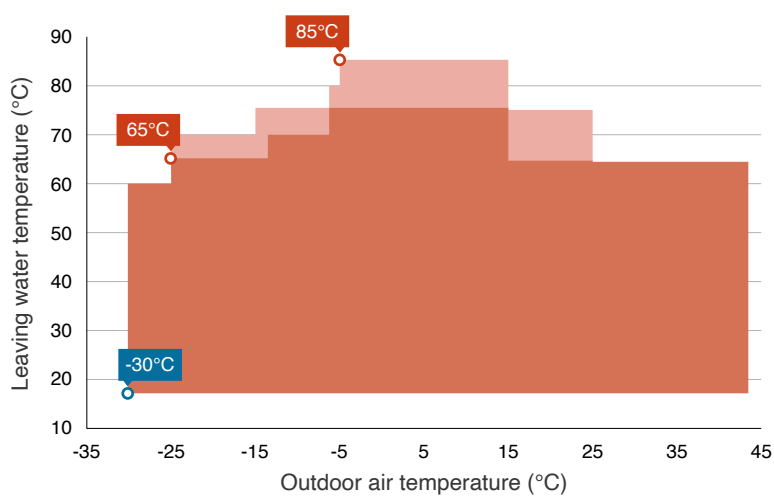

# Schematics

Simplified diagram for illustration only - safety devices may have been omitted for clarity.  
For additional schematics, refer to the installation guide.

Symbol	Description	Symbol	Description
	Isolating valve		Strainer
	Check valve		Temp sensor
	Circulation pump*		3-way valve
	Pressure gauge		Degasser
			Safety valve

## Heating & DHW with Plate Heat Exchanger

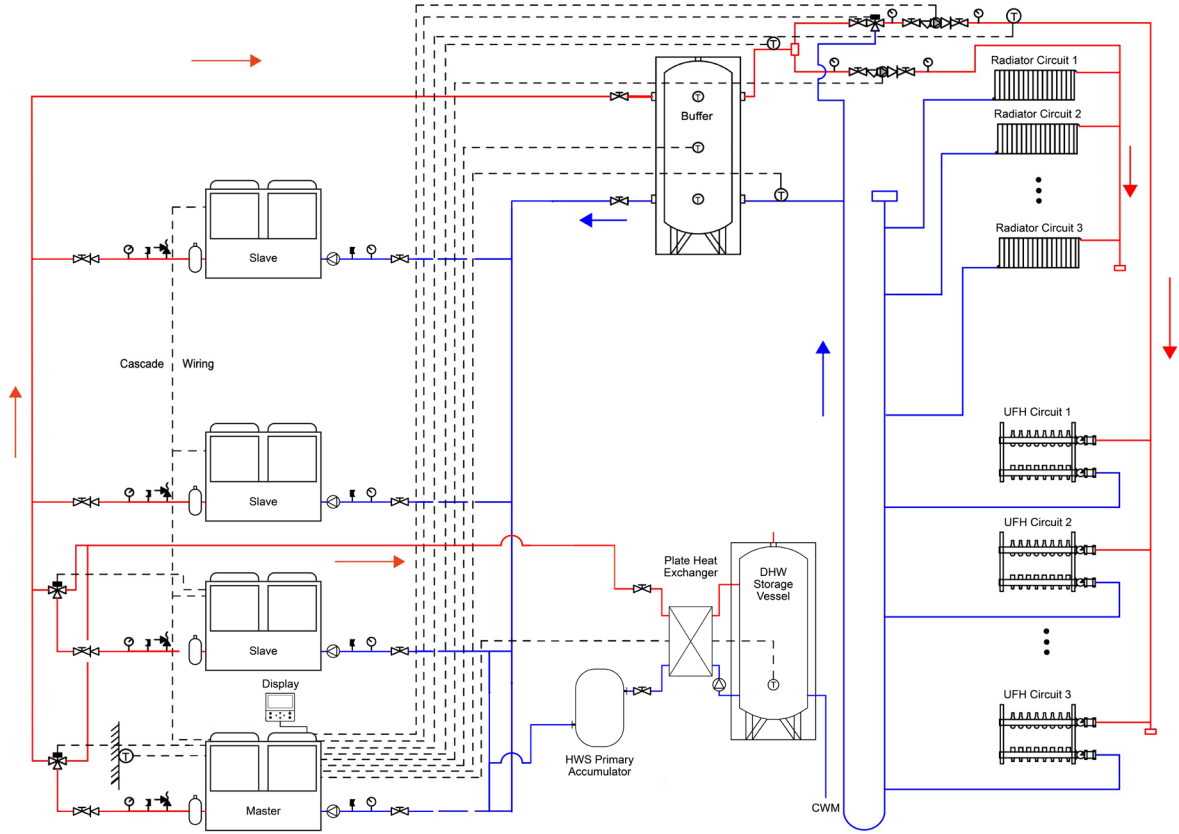

## DHW only

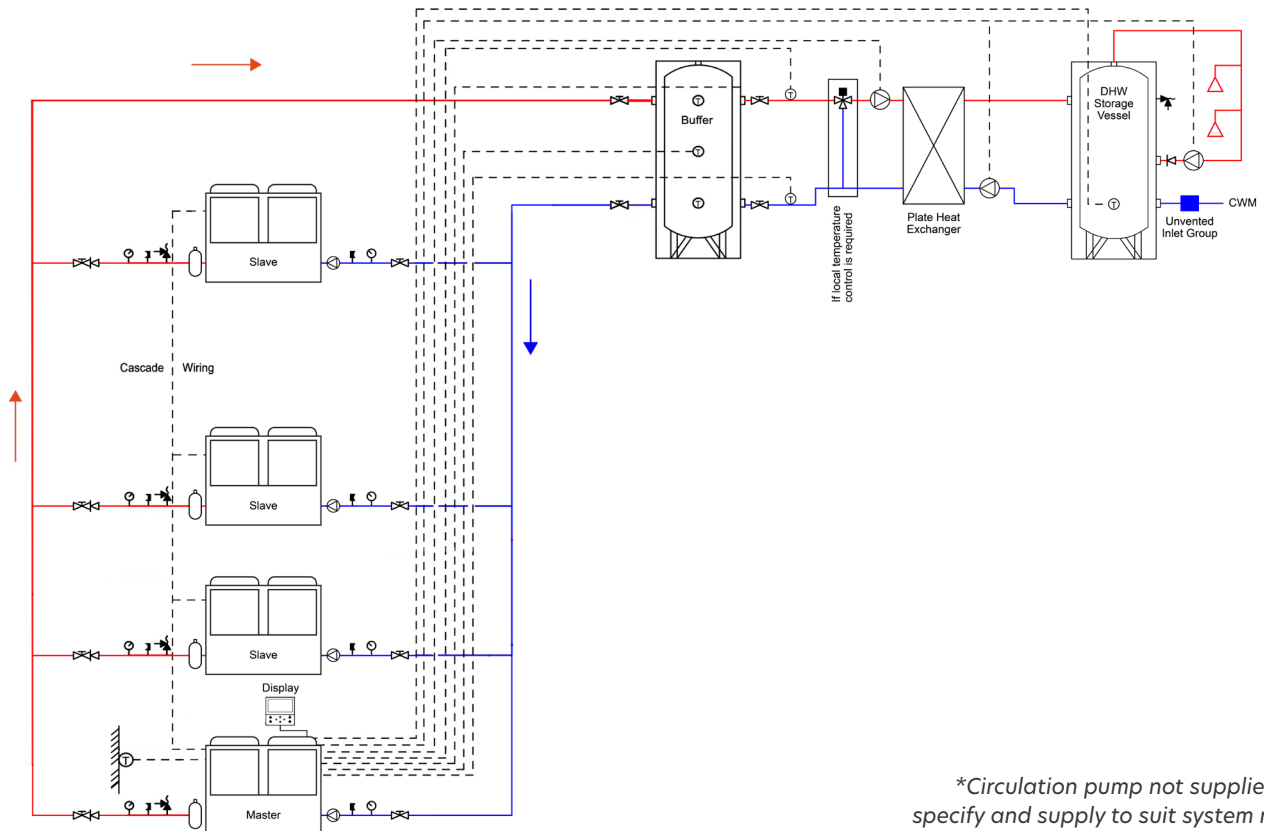

\*Circulation pump not supplied; installer to specify and supply to suit system requirements.

# Heat pump buffer vessels

- Mild steel construction
- 7 bar working pressure
- 5x 1/2" sensor points
- 1 1/2" connection for immersion heater

- A Flanged connection  
 O Drain  
 P Connection for immersion heater

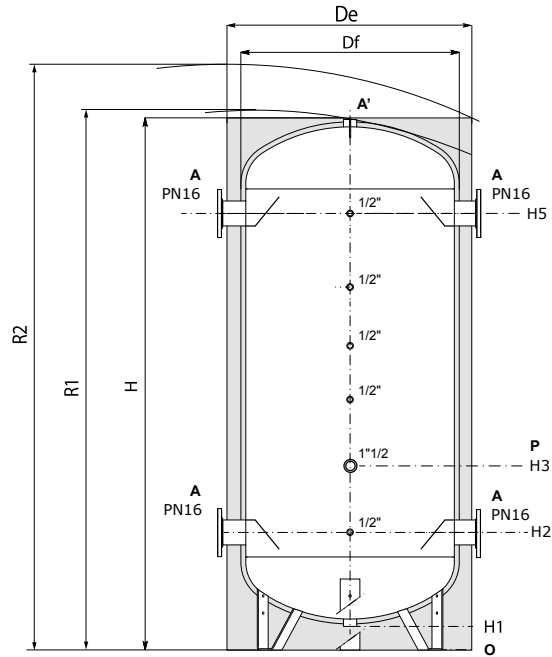

Model	Volume litres	Weight kg	Df	De	H	R1	R2	H1	H2	H3
						mm				
500	478	77	650	910	1880	1940	2030	130	441	741
800	758	105	750	1010	2113	2240	2330	120	413	813
1000	987	141	850	1110	2232	2300	2400	105	479	879
1500	1435	200	950	1250	2492	2650	2760	130	537	927
1500-C	1528	222	1100	1400	2038	2214	2474	104	548	713
2000	1973	233	1100	1400	2537	2750	2870	105	547	710
2500	2294	397	1250	1390	2324	2650	2700	143	682	919
3000	2988	432	1440	1540	2378	2790	2840	127	711	998
4000	3914	494	1600	1740	2436	-	-	105	719	956
5000	4970	714	1600	1740	2936	-	-	105	719	1006

## Controller

The AW290 comes with an advanced controller designed for seamless integration and optimal system performance. Offering precise control and monitoring, it enhances efficiency, flexibility, and ease of use across various applications.

- Cascade control for up to 16 heat pumps
- 0-10V control for seamless system integration
- Three-zone control with diverter valve management
- Modbus/BACnet compatibility for BMS integration
- Weather compensation for enhanced efficiency
- Quiet mode for reduced noise operation
- Real-time energy data: capacity, consumption, and COP
- Weekly scheduling for customised operation
- Frost protection to prevent system damage
- SG ready for smart grid compatibility
- Power-off memory to retain settings after shutdown

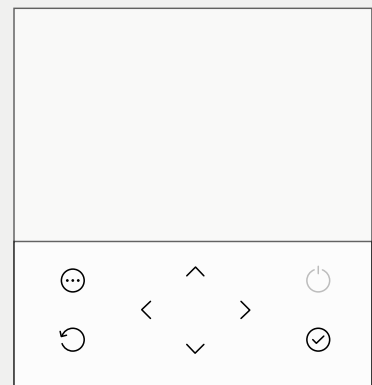

**Modutherm Limited**  
Unit 4 Genesis  
Endeavour Drive  
Basildon, SS14 3WF

**Modutherm® Limited**  
**modutherm.co.uk**  
Tel: 0345 521 5666  
modutherm@modularhg.co.uk

Your local contact is:

