

ADDENDUM NO. 1

**ROSELLE PARK DISTRICT
GOOSE LAKE PARK PATH REPLACEMENT PROJECT
ROSELLE, ILLINOIS
MAY 19, 2026**

This Addendum shall include the following Clarifications & Modifications to the Contract Documents, Specifications, and Plans.

Clarification:

- The Roselle Park District has approximately 150 tons of aggregate base course available for use on the project. The Owner-furnished material may be used under the HMA path and/or PCC path/sidewalk, as approved by the Engineer. Bidders shall account for the availability of this Owner-furnished material in their bids. The quantity of Owner-furnished aggregate base course incorporated into the work will be deducted from the appropriate aggregate base course pay item based on the final approved use location.
- The Contractor shall be allowed to reuse clean CA-6 stone from the existing site, provided the material is suitable, free of deleterious material, and approved by the Engineer prior to incorporation into the work. Any reused aggregate shall meet the intent of the contract requirements for aggregate base course and shall be placed, graded, and compacted in accordance with the contract documents. Material deemed unsuitable by the Engineer shall be removed and replaced at no additional compensation.

Modification:

- Sheet 5 of 46, "Typical Cross Sections," has been revised to clarify that aggregate base course for the PCC path/sidewalk is not incidental to the PCC Trail pay item and shall be paid under the applicable aggregate base course pay item.
- Sheet 5 of 46, "Typical Cross Sections," has been revised to add a note regarding approximately 150 tons of Owner-furnished aggregate base course available from the Roselle Park District for use on the project.

This Addendum consists of two (2) pages.

This Addendum No. 1 has been prepared by:



Derek R. Thompson PE
Business Unit Leader – West Region

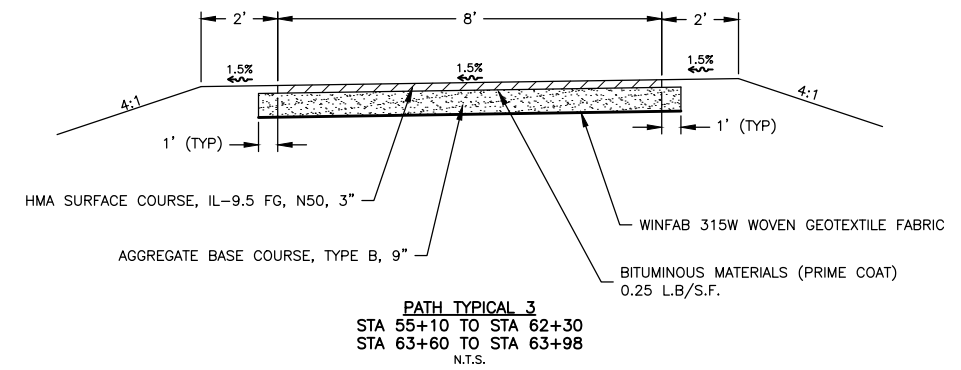
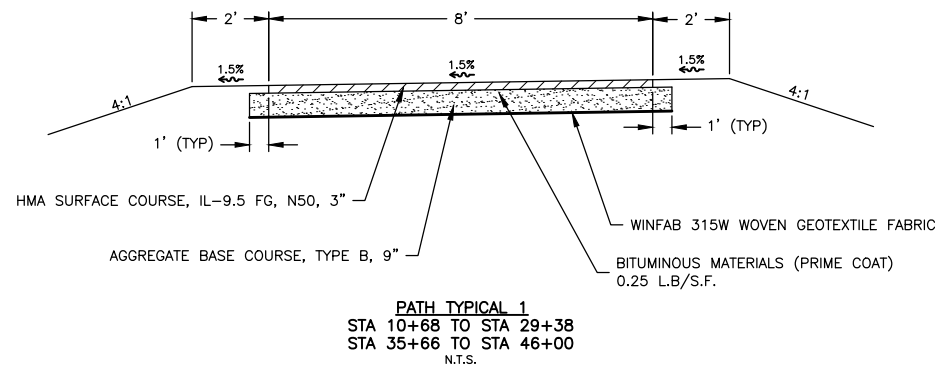

NOTE: BITUMINOUS MATERIALS (PRIME COAT) IS CONSIDERED INCIDENTAL TO THE HMA SURFACE COURSE

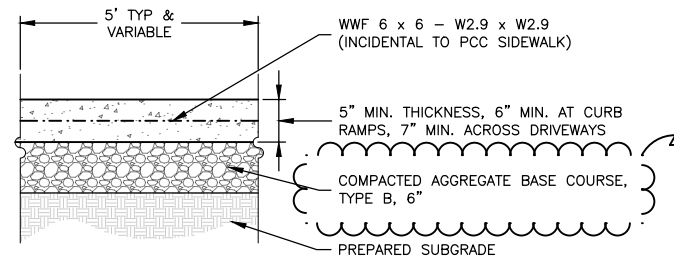

NOTE: OWNER-FURNISHED AGGREGATE BASE COURSE

THE ROSELLE PARK DISTRICT HAS APPROXIMATELY 150 TONS OF AGGREGATE BASE COURSE AVAILABLE FOR USE ON THE PROJECT. THE MATERIAL MAY BE USED FOR AGGREGATE BASE COURSE UNDER THE HMA PATH AND/OR PCC PATH/SIDEWALK, AS APPROVED BY THE ENGINEER. OWNER-FURNISHED AGGREGATE INCORPORATED INTO THE WORK WILL BE MEASURED AND DEDUCTED FROM THE APPLICABLE AGGREGATE BASE COURSE PAY ITEM. SEE ADDENDUM NO. 1 FOR ADDITIONAL REQUIREMENTS.

NOTE: CONCRETE SHALL MEET IDOT CLASS SI SPECIFICATION.

CONTROL JOINTS SHALL BE PLACED EVERY 5' OR APPROVED BY THE ENGINEER TO MATCH EXISTING WALK.

TOPSOIL STRIP, TOPSOIL & GRASS SEEDING ALONG EACH SIDE OF WALK INCLUDED AS INCIDENTAL TO SIDEWALK WHEN SIDEWALK INSTALLED IN LAWN AREA.

ALL CONNECTIONS TO EXISTING PCC PAVEMENT SHALL BE MADE WITH NO.4 TIE BARS @ 24" CTS.

PCC PATH DETAIL
N.T.S.

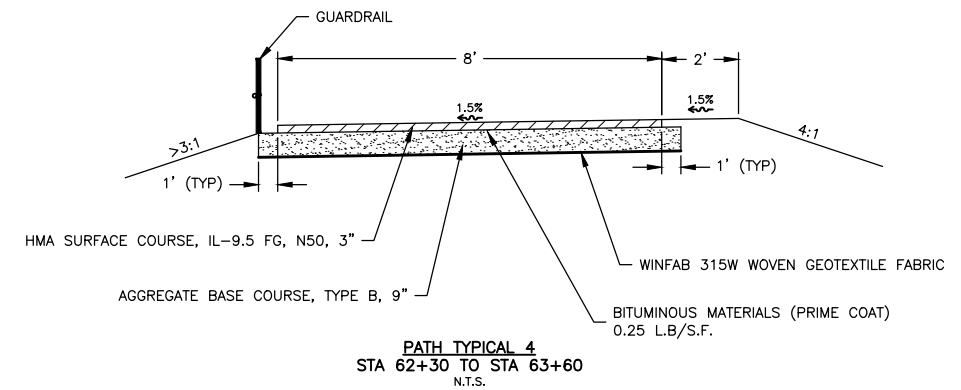
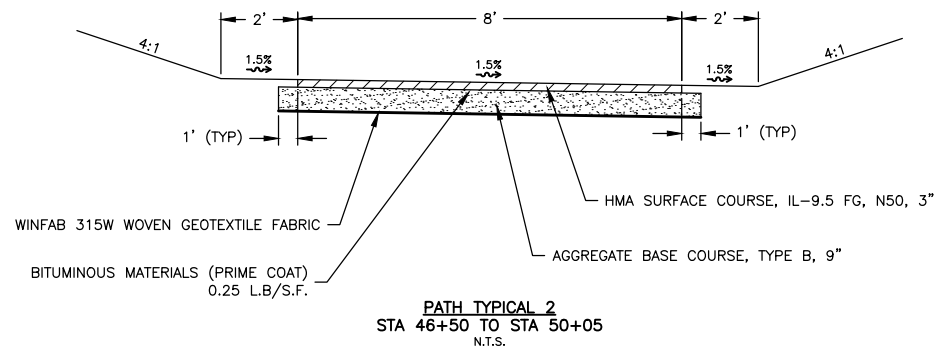

REVISIONS		
REV. NO.	DESCRIPTION	DATE
1	ADDENDUM NO.1	05/19/28