



WSU-600S, WSU-600BS // 60cm // SILENT



// WSU-600BS (60cm)

3YR
LIMITED
WARRANTY



Sleek and silent, the WSU-600S (Stainless) and WSU-600BS (Black) feature a powerful Ecodrive® motor, 1-speed wall switch, dual lifetime LED lights, and dishwasher-safe filters. Choose from flexible External or Inline Ecodrive motor systems to suit your installation. Compact 600mm design with 3-year canopy and motor warranty.

PRODUCT DESCRIPTION ECODRIVE OPTIONS

- Black or stainless steel finish
- Silent Ecodrive® motor system
- Simple wall switch operation (wall switch is not provided)
- 1 x speed level
- 2 x LED lights with a lifetime warranty
- Dishwasher safe filters lifetime warranty
- 3 Year Warranty on Canopy and Motor

- **ET** single external motor
 - 850 m³/h airflow
 - 200mm Steelflex™ ducting (4m)
 - install roof/wall
- **IL750** single inline motor
 - 750 m³/h airflow
 - 150mm Flexi-Duct (6m)
 - install roof or floor cavity
- **IL1000** single inline motor
 - 1000 m³/h airflow
 - 200mm Flexi-Duct (6m)
 - install roof or floor cavity

TECHNICAL DATA

WSU-600S, WSU-600BS
 • Dimensions: (W x D)
 600mm x 295mm

* Note: 2 gang wall switch is not provided



// WSU-600S (60cm)



WSU-600S, WSU-600BS // 60cm // SILENT

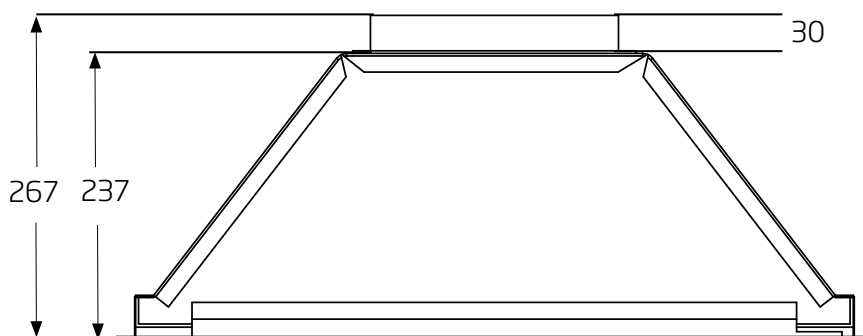
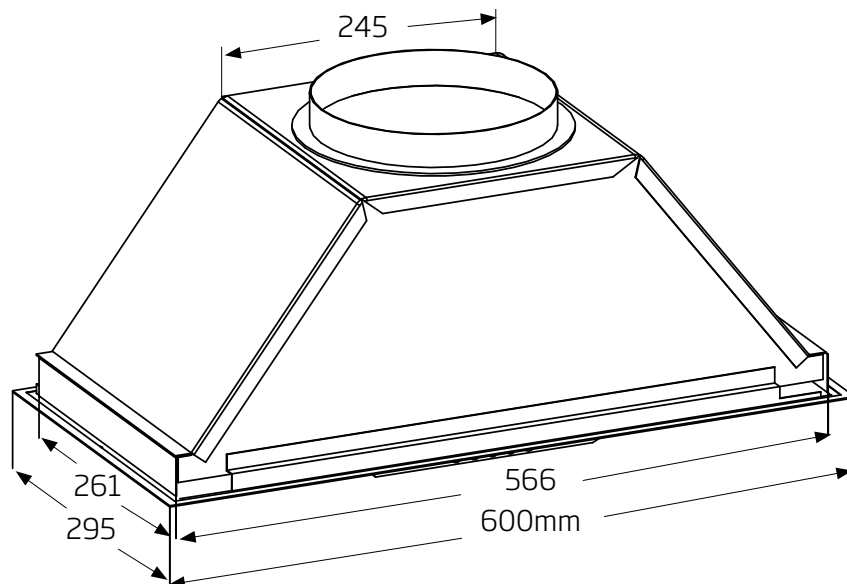

* Note: 2 gang wall switch is not provided

Model: WSU-600S, WSU-600BS

Feeding Voltage: 220-240V 50Hz

Max Lamp Power: 2 x 3W