



EV-6UCQ, EV-9UCQ // 60cm & 90cm // SILENT



// EV-9UCQ (90cm)

PRODUCT DESCRIPTION ISODRIVE® OPTIONS

- stainless steel finish
 - silent motor system
 - manual controls
 - single speed level
 - LED lighting
 - aluminium, dishwasher safe filters
 - 3 Year Warranty on rangehood
 - 10 Year Warranty on Isodrive® motor
- **ST** single external motor
 - 900 m³/h airflow
 - 200mm SteelFlex™ ducting (4m)
 - install roof/wall
 - rated power: 57W
 - **SP** single external motor
 - 1600 m³/h airflow
 - 200mm SteelFlex™ ducting (6m)
 - install roof/wall
 - rated power: 155W
 - **STINL** single inline motor
 - 900 m³/h airflow
 - 200mm SteelFlex™ ducting (4m)
 - 200mm wall vent
 - rated power: 57W
 - **SPINL** single inline motor
 - 1600 m³/h airflow
 - 200mm SteelFlex™ ducting (6m)
 - 200mm wall vent
 - rated power: 155W

TECHNICAL DATA

EV-6UCQ

- dimensions: (W x D)
600 x 295mm
- 2 x mesh filters

EV-9UCQ

- dimensions: (W x D)
900 x 295mm
- 3 x mesh filters



// EV-9UCQ (90cm)



// EV-6UCQ (60cm)

Perfectly designed for discreet mounting inside cabinetry, the popular EV-9UCQ and EV-6UCQ fit perfectly into kitchen cabinetry and are ideal for kitchens where space is limited, or where the rangehood needs to be out of sight.

Powerful and efficient extraction of steam, smoke and odours leaves kitchen air fresher for longer.





EV-6UCQ, EV-9UCQ // 60cm & 90cm // SILENT

EV-9UCQ

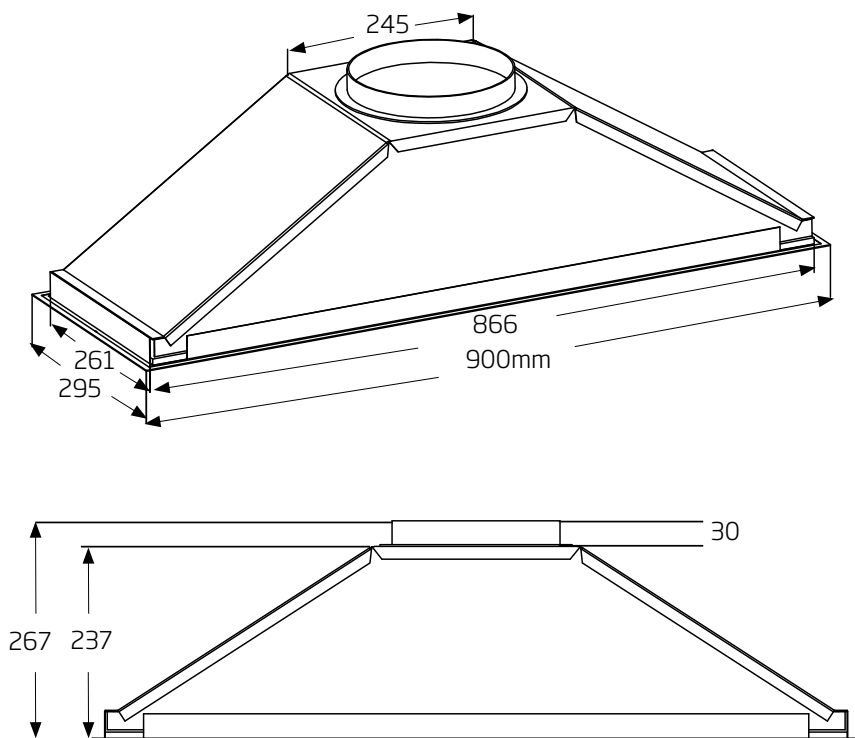

EV-6UCQ

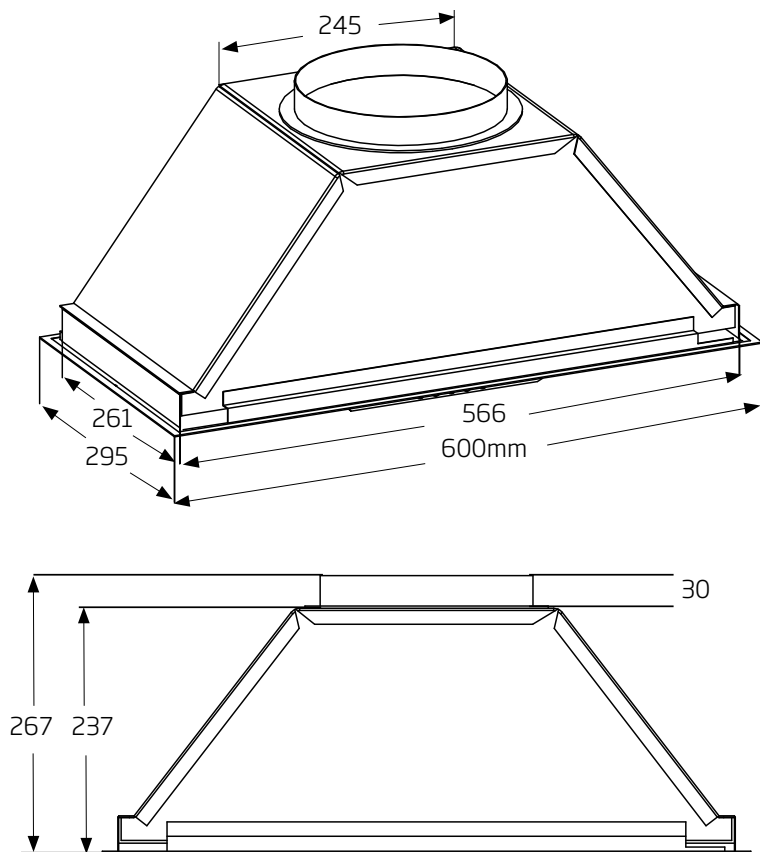

Model: EV-9UCQ, EV-9UCQ

Feeding Voltage: 220-240V 50Hz

Max Lamp Power: 2 x 3W