

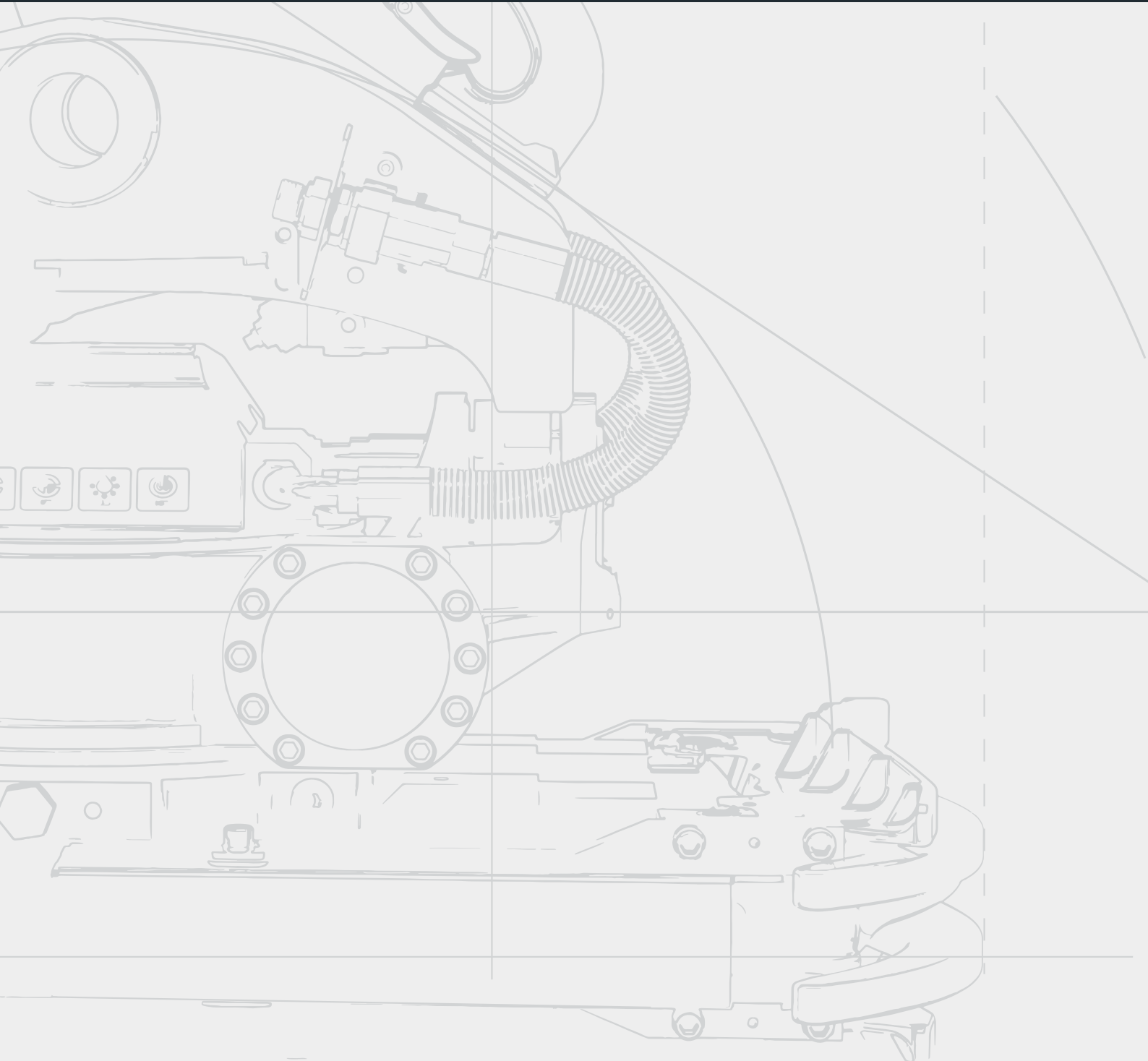

Control System - ICS



Overview

The product described in the document consists of components for the ICS control system. The overviews show standard equipment and options.

Refer to the illustrations and lists below as well as on the following pages.

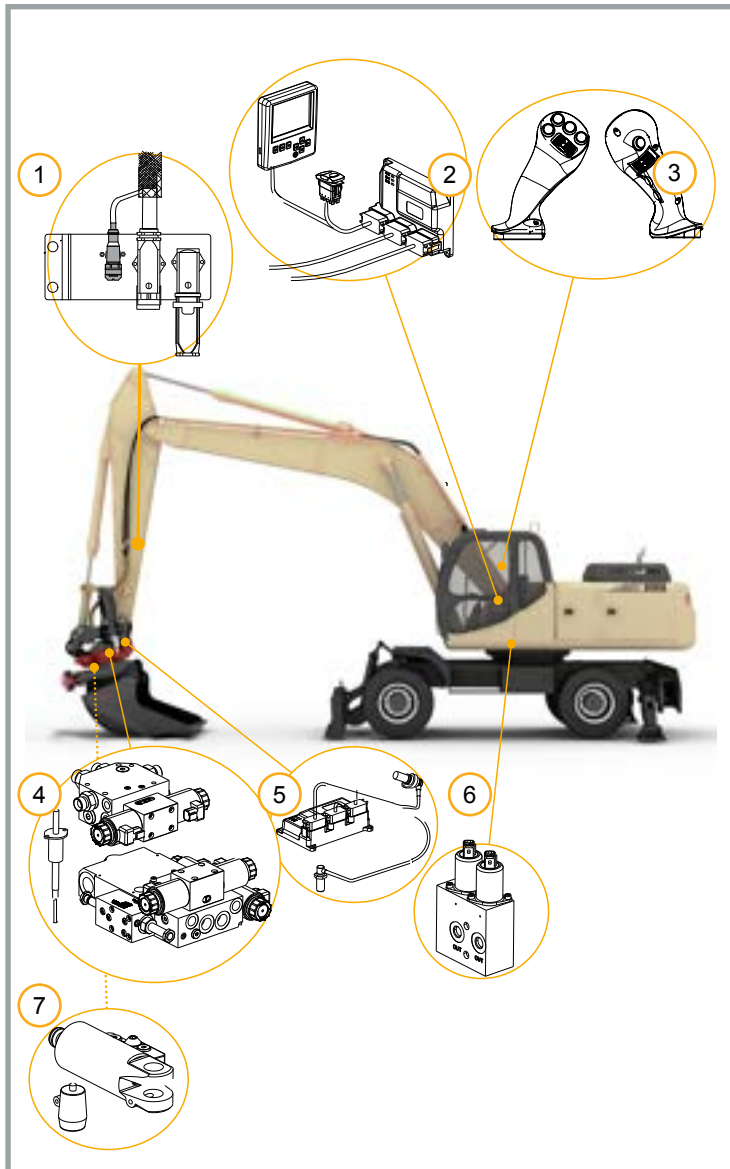

ICS control system

ICS control system consists of the following components:

1. Harness, Boom Contact (SecureLock, Machine coupler/Quick coupler (excavator)) Contact with safety plug
2. Display Switch for tool replacement. Cab control unit, CCU
3. Handles with controls to operate Rototilt® functions and base machine/ excavator functions are ordered separately
4. Valve block Electric swivel
5. Rototilt® control unit, TCU Zero-position sensor. (ICS sensor, ICS SecureLock) Frequency sensor. (ICS sensor, ICS SecureLock)
6. Feeder that regulates the oil flow to the hydraulic circuit for extra equipment on the base machine/ excavator.
7. Lock cylinder sensor. (ICS SecureLock) LED lighting. (ICS SecureLock)



IMPORTANT - Read the user manuals for the control system, tiltrotator and base machine/excavator before starting work. Pay particular attention to the safety instructions.



IMPORTANT - Pressurising the Rototilt® hydraulic system means that the quick coupler locking function will be pressurised.



IMPORTANT - Connected safety plug ensures that the base machine/excavator's quick coupler is not opened accidentally during use of the tiltrotator.



IMPORTANT - The control units have a similar appearance but the content differs. They are not interchangeable.

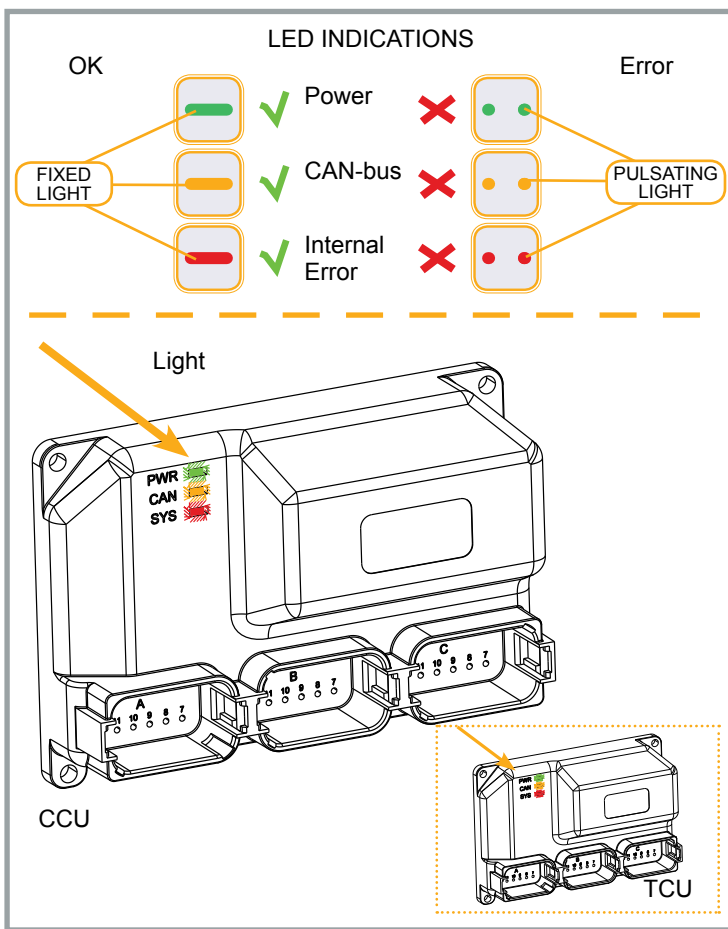

WARNING! A problem has occurred if the buzzer sounds without activating the quick coupler locking function switch. The display shows information about the current problem.

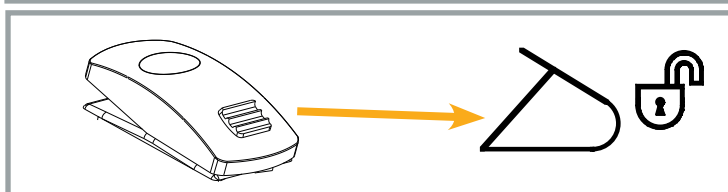

Control unit

The control units have three LEDs: green, orange and red. When the system is working correctly, all LEDs light and with no flashing.

When a malfunction occurs the relevant LED begins flashing.

PWR (green) shows whether the unit is powered up.

CAN (orange) shows whether communications with CAN bus is working.

SYS (red) shows whether the unit's internal components are working correctly.

The control units are not interchangeable.

Cab control unit, CCU

The control unit receives signals from the handles and switches.

The control unit sends signals to the feeder and tiltrotator via CAN bus.

Rototilt® control unit, TCU

The control unit receives signals from the cab control unit, and from the sensor in Rototilt®.

Rototilt® control unit sends signals to valves and LED lamp.

There is a sensor in the Rototilt® control unit that detects the tilt angle.

Display

Settings, calibration and activation of certain functions are made via the display and its keys.

There is a buzzer in the display that sounds to attract the operator's attention if the quick coupler locking function is open or in the event of a fault.

Switch, quick coupler locking function

The quick coupler locking function switch is interlocked. This prevents accidental activation of the quick coupler locking function.

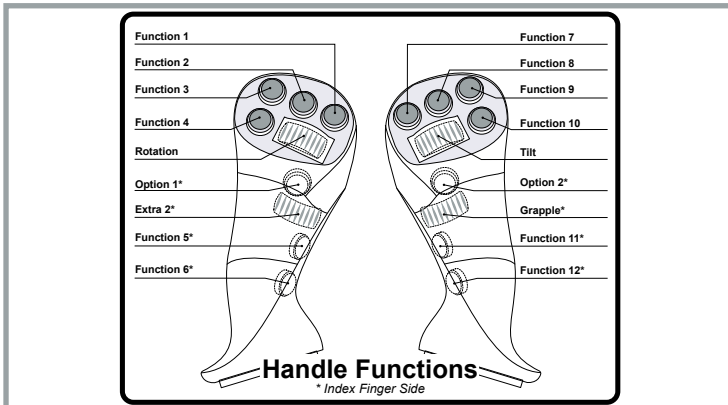
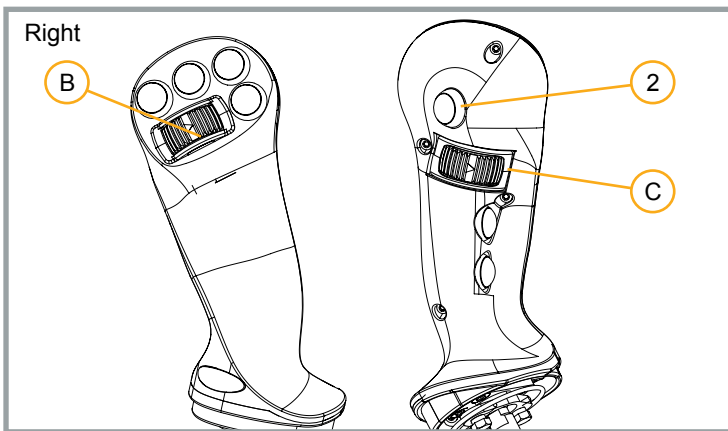
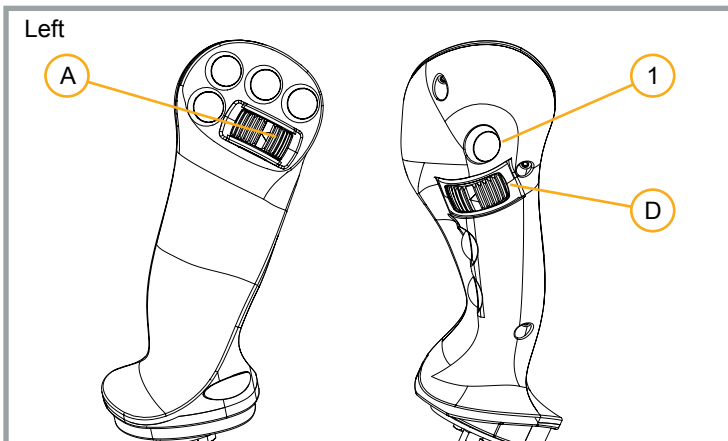

IMPORTANT - The base machine/excavator's factory mounted handles have been replaced with handles adapted for ICS. Carefully check the changed functions, for both the base machine/excavator and Rototilt®.

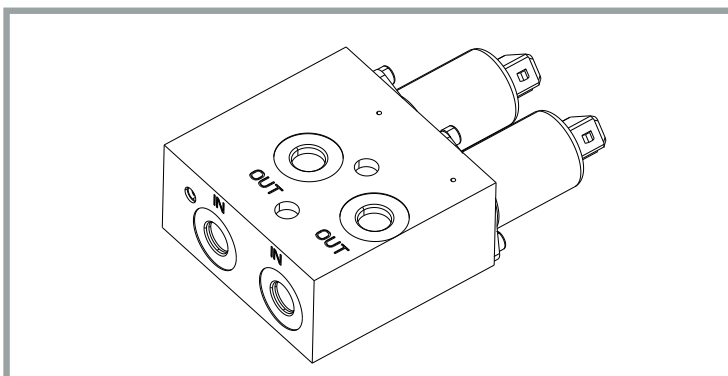

Handle

The handles are equipped with switches and rollers to control Rototilt® functions and base machine/excavator functions.

The standard version has 2 rollers and 7 switches in each handle.

There are 5 switches for the base machine/excavator functions.

The handle functions are configured by an authorised installer. Functions are programmed according to the following standard unless otherwise stated.

Left Handle

- A Rotation
- 1 Option 1
- D Extra 2

Right Handle

- B Tilt
- 2 Option 2
- C Grapple/Extra

Feeder

The feeder regulates the oil flow to the base machine/excavator's extra hydraulic circuit.

The servo pressure that regulates the oil flow in the base machine/excavator's main valve is controlled by the feeder. The feeder is variably controlled via the control unit with the handles' rollers.

Rototilt® operation

When the 8-way connector in the boom harness is connected the feeder is regulated in parallel with the valves on Rototilt®. The hydraulic flow is adjusted for this. The flow runs in one direction.

Regulation of extra hydraulics

When the base machine/excavator is operated without Rototilt® the feeder can regulate the oil flow in the base machine/excavator's circuit in both directions.

Operation

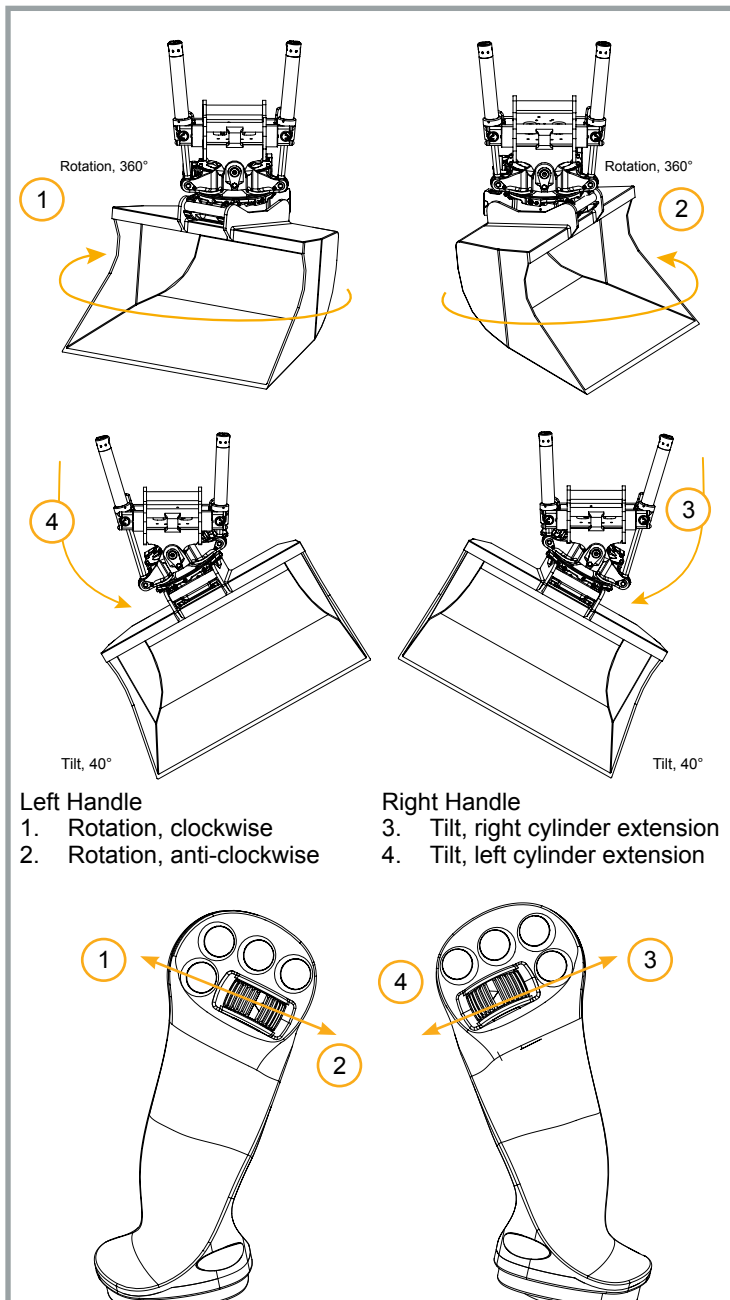

IMPORTANT - When using Rototilt® the base machine/excavator pedals must not be used to further increase the oil flow, as this can result in serious damage to Rototilt®.

Activate the ICS control system

The system is activated when the base machine/excavator is in the ignition position.

Operating Rototilt®

The ICS control system permits tilt, rotation, grapple and an extra function to be used in parallel and to be regulated proportionally.

ICS works in parallel with any pedals on the base machine/excavator. When using Rototilt® the base machine/excavator's pedals must not be used to regulate the oil flow.

A calibrated ICS system provides each system with its optimal flow. The Rototilt® can be seriously damaged if the pedals on the base machine/excavator are used to further increase the flow.

Carefully check the positions and functions of the switches.

The appearance and placement of switches may vary depending on the base machine/excavator and handle.

The selected function opens the equivalent directional valve on Rototilt®.

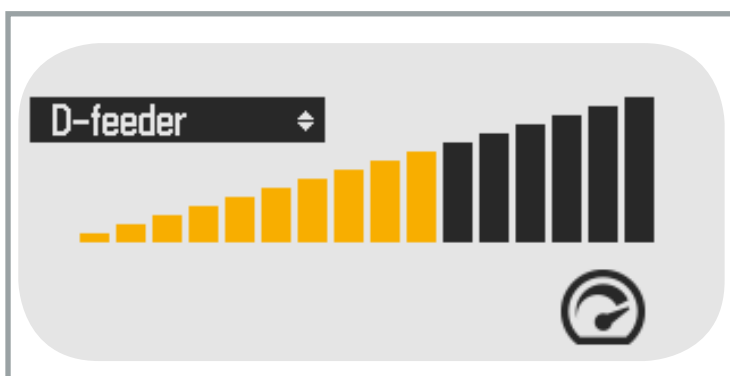

Speed

The speed of all functions can be adjusted.

The adjustment is made via Display, Speed settings menu.

The speed can be adjusted in general for all functions. The speed can also be adjusted separately for each individual function.

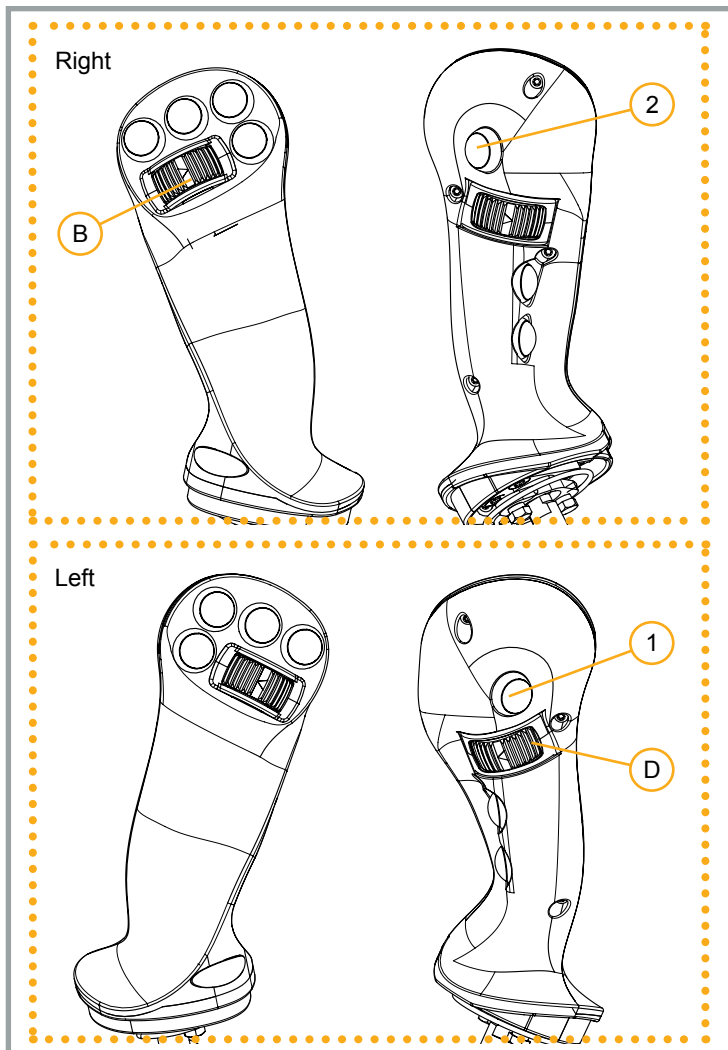

Pulsating function

The ICS control system can give a pulsating, shaking function to spread material out of a tilting bucket, for example.

Press button 1 and regulate the speed with roller B.

Non-variable hydraulic flow, Extra 2

The flow can be locked using switch 2 (Hold) when the intended level is reached with roller D (Extra2). Press and hold the button for 0.5 seconds.

The next time the button (2) is pressed the function releases and the flow ceases.



IMPORTANT -

Carefully check the relevant functions, on the display or the handle sticker.

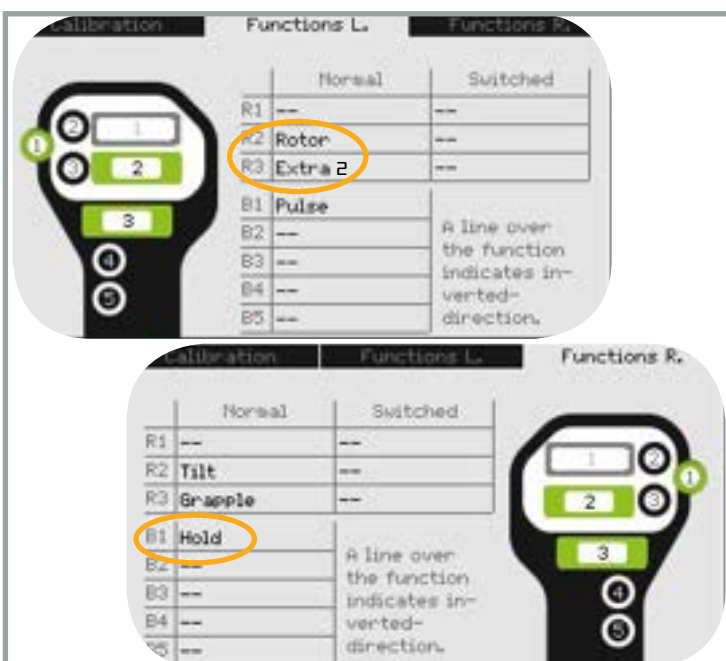

Operating Rototilt® Quick coupler

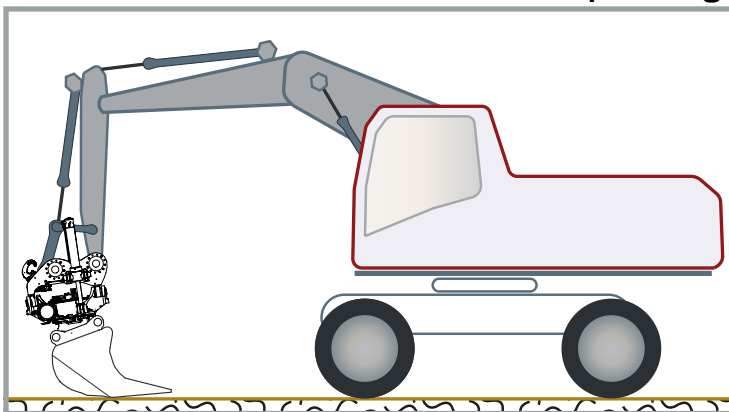

Detach the tool

Position the tool horizontally, resting on firm ground or so that the tool cannot slide out of the attachment when the quick coupler locks are opened.



IMPORTANT - If the tool can fall or change position in connection with the procedure, there is a risk of damaging the tool and/or quick coupler.



IMPORTANT - It is only possible to open the lock when the start menu is visible or from the troubleshooting menu.



Check that the display shows the start menu. The icon for the quick coupler locking function is shown above the green function key.

First press the green function key and release it.

The buzzer sounds.

Now move the quick coupler locking function switch to the open position.

The switch is enabled for a period of 10 seconds.

The lock remains open as long as the switch remains open, but pressurising is only performed during the preset time period, 3-12 seconds.

The selected time can be checked on the display, *Menu settings*.

The switch must be switched on and then off again to repressurise the hydraulic cylinder.

See the user manual for the quick coupler.

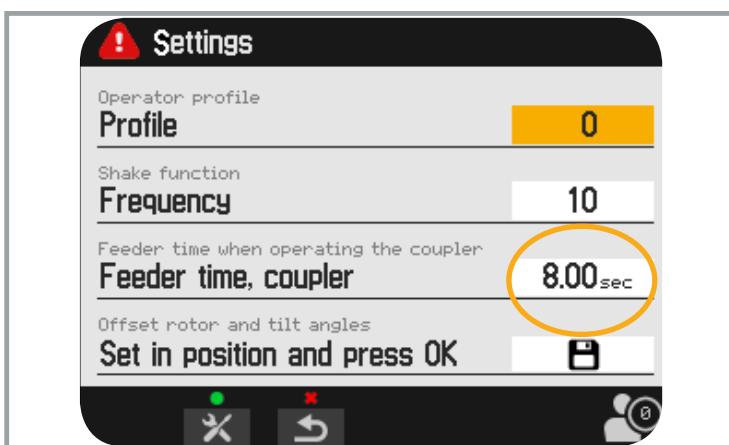

Indicator Rod - Open

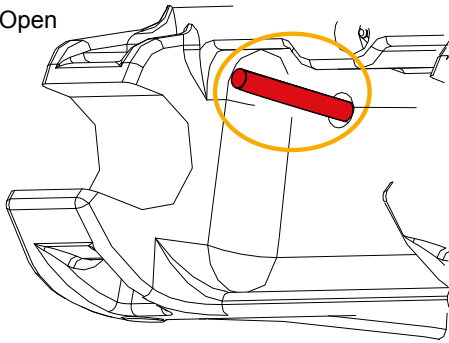

When Rototilt® is pressurised hydraulically the quick coupler locking function is opened. The indication on the quick coupler shows that the lock is open.

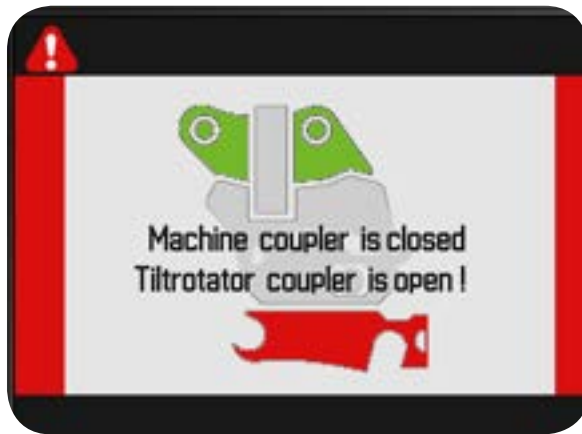

A warning is shown on the display if the quick coupler is in the open position.

The base machine/excavator can be equipped with different combinations of quick coupler and machine coupler. The figure and text on the display are dependent on the combination.

Both the quick coupler and the machine coupler are available with and without electronic monitoring (SecureLock).

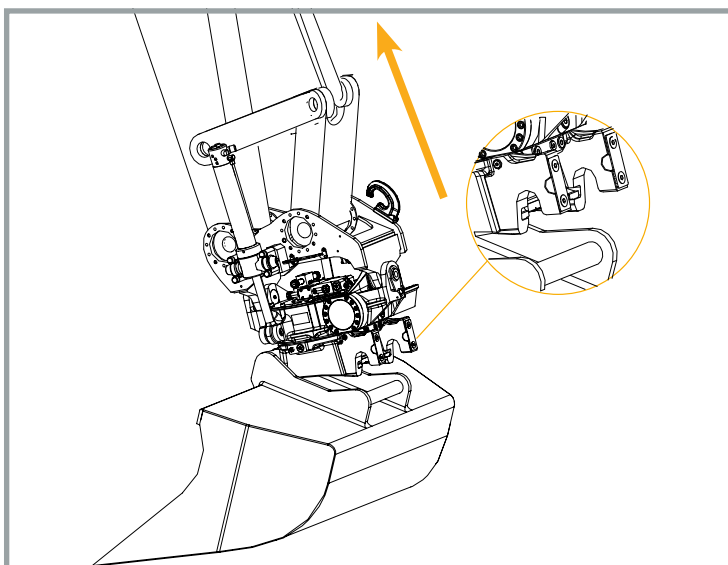
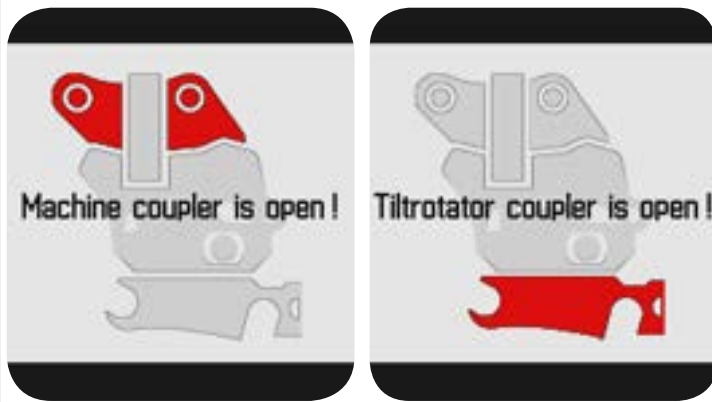

When the quick coupler's locking wedge/locking bolts are fully open, the tool can be detached by slowly retracting the bucket cylinder.

Return the switch to its original position to close the lock.

Pressurising is conducted for a preset time, maximum 12 seconds. The selected time can be checked on the display, *Menu settings*.

The switch must be switched on and then off again to repressurise the hydraulic cylinder.



INFO - If the quick coupler locking function is in the closed position when the attachment is attached, the switch must be switched on, off and on again.

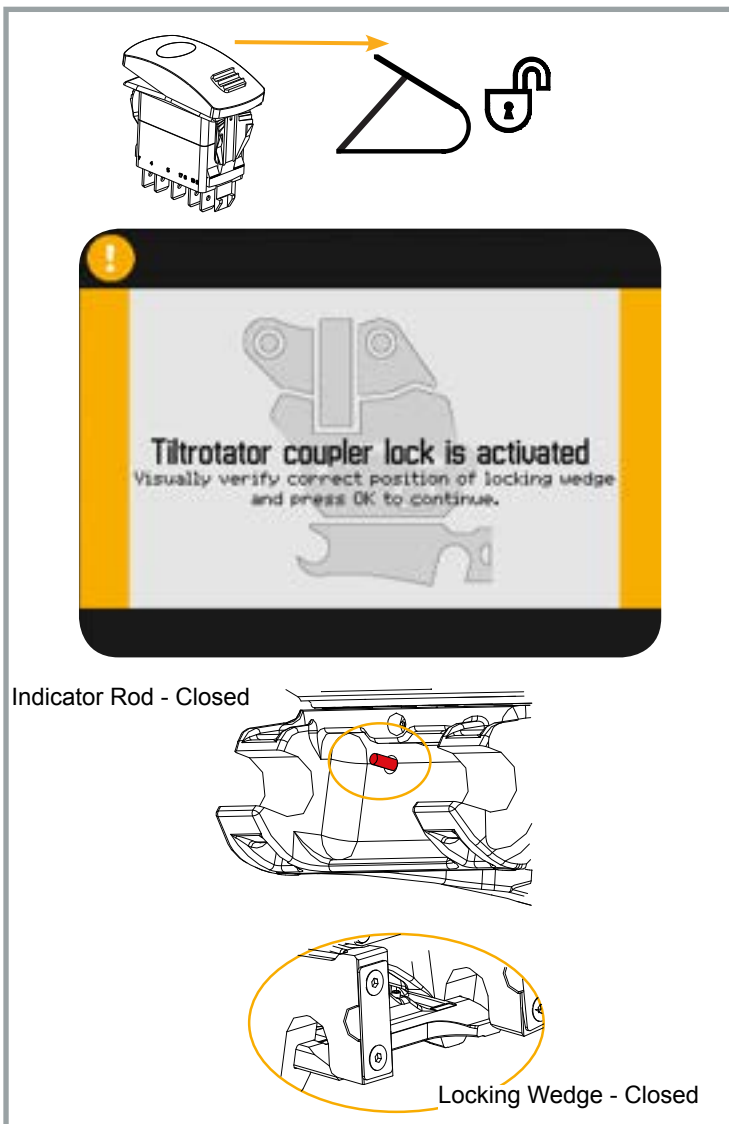

Indicator Rod - Closed

Locking Wedge - Closed

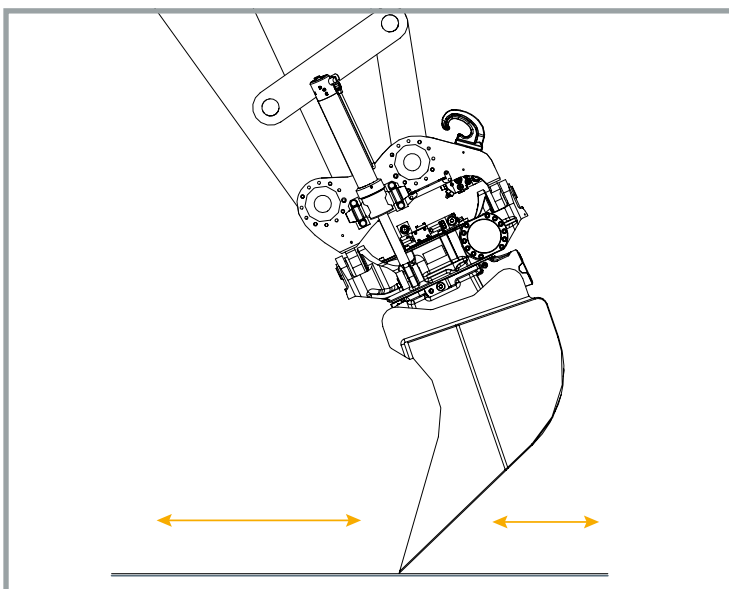

Attach the tool

Open the quick coupler and check that the indication shows that the coupler is open.

Refer to the Quick coupler section.

Position the quick coupler so that its coupling mechanism is correctly aligned with the tool's attachment frame.

Now slowly pivot the tool by extending the bucket cylinder.

Adjust with small shaft or boom movements if necessary.

Return the switch for quick coupler locking function.

The quick coupler's locking cylinder returns to its closed position. The indication on the display confirms that the switch is in the locked position.

The indicator on the quick coupler shows that the quick coupler locking function is in the locked position.

Inspection of quick coupler locking function

Inspection of the quick coupler locking function

Even if the indication shows that the locking wedge has engaged in the locked position, perform the following test to check the tool is attached securely:

Push the tool forwards towards the ground, see the figure to the left. Operate the bucket in this position, inwards and outwards, to check that the locking wedge has locked the tool correctly.

Rotate the quick coupler and check from the operator position that the locking wedge/locking bolts have engaged.

In the event of uncertainty, exit the machine and conduct a visual check.

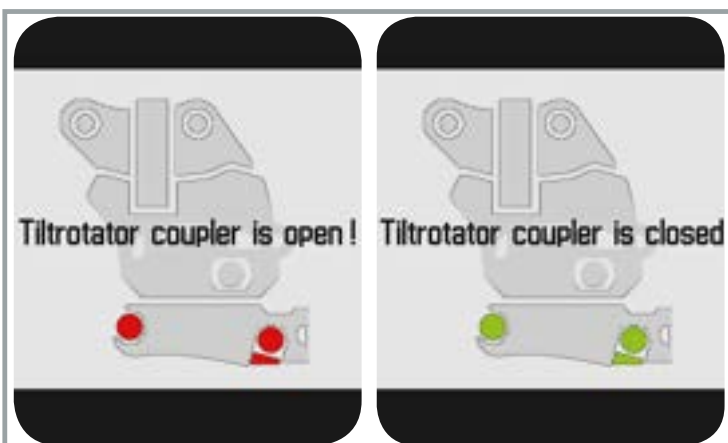
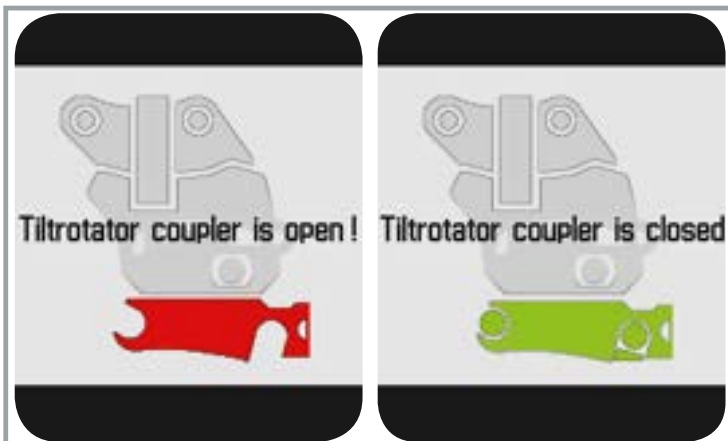

Quick coupler with SecureLock

Operate in the same way as the quick coupler without SecureLock, see above.

When the quick coupler is opened a warning is given that the locking cylinder has been retracted and is in the open position.

When the quick coupler is closed, the message indicates that the locking cylinder is extended and is in a securely locked position.

Inspection of quick coupler locking function.

A warning text appears on the display if the tool is not coupled correctly.

If you do not intend to couple a tool, the warning must be acknowledged.

First press the green function key and release it.

Now press the OK function key. The buzzer warning signal stops.

Return to the start menu using any key.

A visual warning will be shown at 30-second intervals as long as Rototilt® is running without a tool and remains visible until any key is pressed again.

Quick coupler QuickChange™

Operation is the same as for the quick coupler; see above.

When the quick coupler is opened a warning is given that the locking bolts has been retracted and that the quick coupler is in the open position

When closing the coupler, the first shaft (1) is engaged, followed by shaft (2) and finally the locking bolts (3)..

The quick coupler locking function cannot be closed until both shafts in the attachment frame are positioned correctly.

The position on the quick coupler's three sensors are monitored continuously. All sensors are shown in green on the display when a tool is coupled correctly.

Inspection of quick coupler locking function.

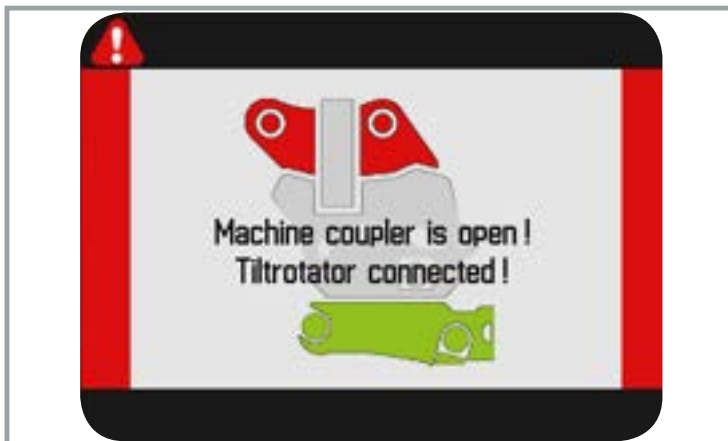

Detach Rototilt®

Always park the tiltrotator on a stable and flat surface, without the tool. Make sure that Rototilt® cannot tip over.

Disconnect the hydraulic hoses and harness between the Rototilt® and the base machine/excavator. The tiltrotator is now detached from the base machine/excavator.

If the machine coupler/quick coupler (excavator) is open while the harness to the tiltrotator is still connected, a warning is shown on the display.

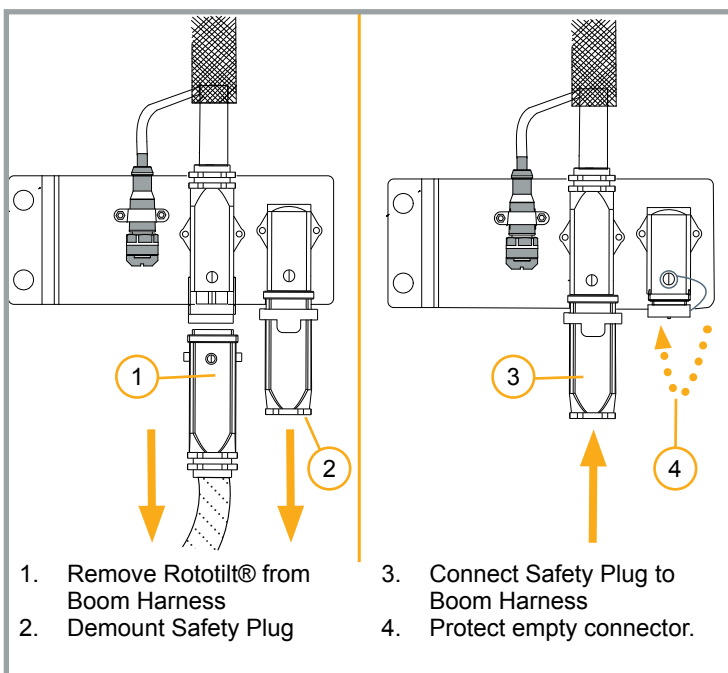

Safety plug

The function is used to lock the machine coupler/quick coupler (excavator) while the tiltrotator is mounted. The lock prevents accidental opening of the machine coupler/quick coupler (excavator).

Disconnect the Rototilt® contact.

Remove the safety plug and connect it to the boom harness contact.

Control of the machine coupler/quick coupler (excavator) works normally again.

Operating extra hydraulics

Detach Rototilt®.

Now select regulation of extra hydraulics on the display by activating double feeder. Confirm with the OK function key.

For return to Rototilt® control: First connect the tiltrotator and then connect it to the base machine/excavator.

Now select Rototilt® operation on the display and confirm the selection with the green function key and then the OK function key.

Control of the oil flow in the base machine/excavator's extra hydraulics circuit can be performed using a roller or switch. Both options work in parallel with any pedals on the base machine/excavator.

Roller for the tilt function B regulates the flow in both directions.



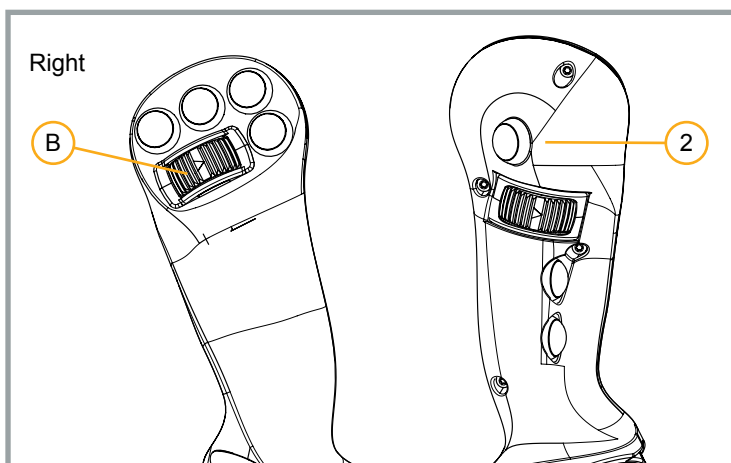

Non-variable hydraulic flow

The flow can be locked using switch 2 when the intended level is reached with roller B.

Press and hold the button for 0.5 seconds.

The next time the button (2) is pressed the function releases and the flow ceases.

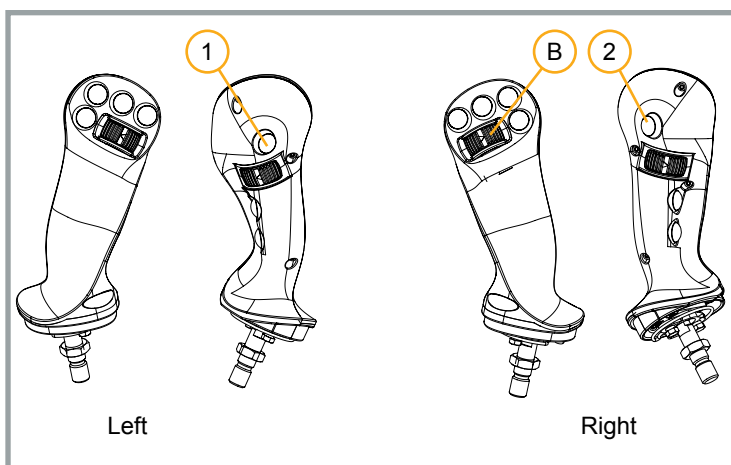

On/Off control

Left handle, switch 1 starts and closes full flow in one direction.

Right handle, switch 2 starts and closes full flow in the other direction.



IMPORTANT - The base machine/excavator's factory-installed handles have been replaced with handles adapted for ICS. Carefully check the changed functions, for both the base machine/excavator and Rototilt®.

Configuration of ICS



i INFO - Profile 0 is reserved for the installer and cannot be modified by another user.



i INFO - A system restart is required to activate a change in language.

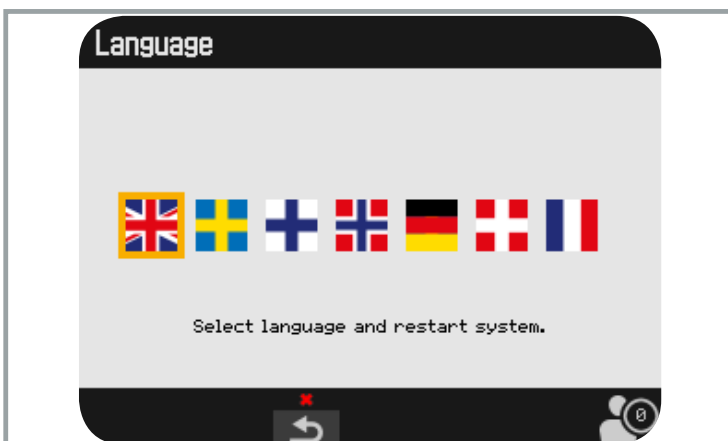

Display

ICS and ICS Direct are configured during installation with the help of the display. Operators can adjust settings on the display and save them in individual profiles. The last selected profile remains active after start-up; change if necessary. The installer uses profile 0.

- A. The top bar indicates the current menu or numbered warnings. Also see alarm list in the *Schematics*. section
- B. 8 sub-menus are shown on the Start menu:
 1. Angles
 2. Speed
 3. Brightness
 4. Language
 5. Information
 6. Handle
 7. Troubleshooting
 8. Settings
- C. Icons are shown on the bottom bar. At the left edge, the icons indicate which function or function key activates in the current view. The current profile is shown in the right corner.
- D. The display has a total of 8 keys:
 9. Three function keys
blue, green & red
 10. Four arrow keys
Change values & navigate the menu
 11. One key to confirm (OK).

Unless otherwise stated, make the changes as follows:
 Move the cursor using the arrow keys.
 Confirm with OK.
 Adjust the values with the arrow keys.
 Confirm with OK.
 Return to the previous menu using the right function key (red).

Language

The language setting is changed via the menu. The 7 options are; English, Swedish, Finnish, Norwegian, German, Danish and French. Select the flag for the preferred language. Confirm with OK. This change is enabled only if the system is restarted.



★ TIP - A profile can apply to a tool instead of a user.

! IMPORTANT - It is only possible to open the lock either when the start menu is visible or from the troubleshooting menu.

Operator settings

Profile

The bottom bar shows the active profile. The profile can be changed either directly when starting using the arrow keys or via menu settings.

Mark the settings in the start menu, confirm with OK.

1. Specified values for the profile are changed using the arrow keys.
2. The selection is confirmed with OK.
3. Return to the start menu with the right function key (red).

The settings that can be saved in a profile are speed, roller direction and position of tilt or rotation. Make the settings under each menu and save to the active operator profile. Profiles 1-4 are available to users of the machine/ excavator.



Quick coupler

The icon for the quick coupler is shown in the lower list on the menus Start and Trouble shooting.

In order to open the quick coupler, the green function key must first be pressed and the released.

The buzzer sounds and the lock switch can then be regulated during a 10-second period.

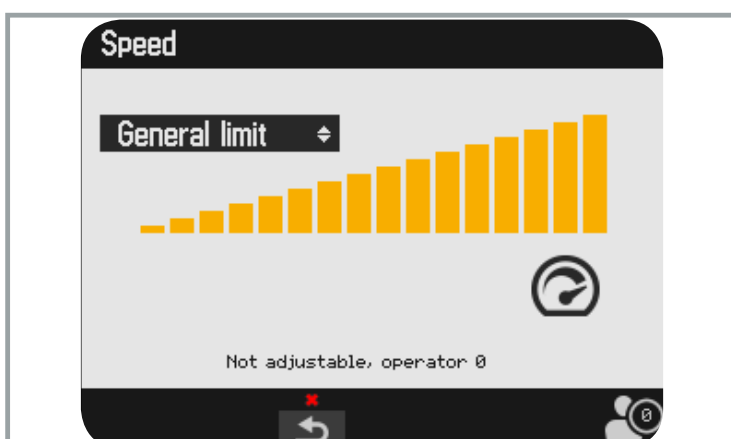

Speed

Both the general speed, and the speed of specific functions are adjusted via the menu.

Navigate between the functions using the vertical arrow keys.

Adjust the values of each function using the horizontal arrow keys. Confirm the settings with OK

General speed cannot be adjusted in profile 0.



IMPORTANT - The base machine/excavator's factory-installed handles have been replaced with handles adapted to the control system.
Carefully check the changed functions, for both the base machine/excavator and alternative control.



INFO - Profile 0 is reserved for the installer and cannot be modified by another user.

Handle

The functions of the rollers and switches are described on the menu.

Information about handle configuration is specified in three places: On the sticker, on the display and in the user manual for the base machine/excavator.

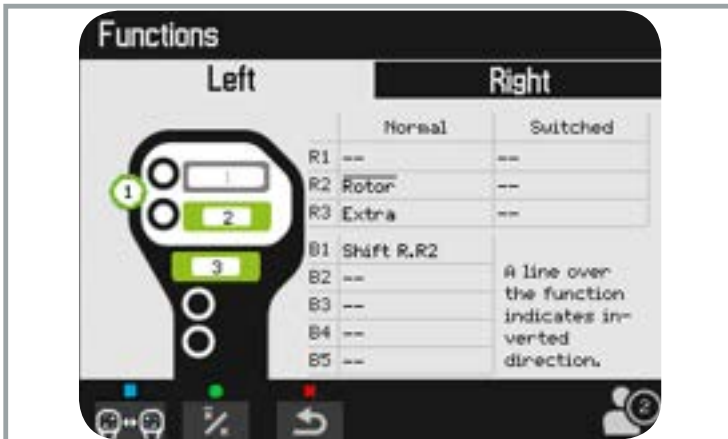

The roller direction can be changed: select the function and confirm with OK.

Shift direction with x/x, middle function button (green).

A dash above the function shows that it is inverted. Confirm with OK.

The user can toggle the position of tilt and rotation.

Switch the position using the left function button (blue). A warning text will now be displayed in the menu view.



A larger warning text is also displayed upon each start-up of the system, and upon each activation of the shut-off lever. The warning must be confirmed with OK to activate the tiltrotator's functions.

The ability to switch positions for the rotation and tilt functions should be used as seldom as possible.



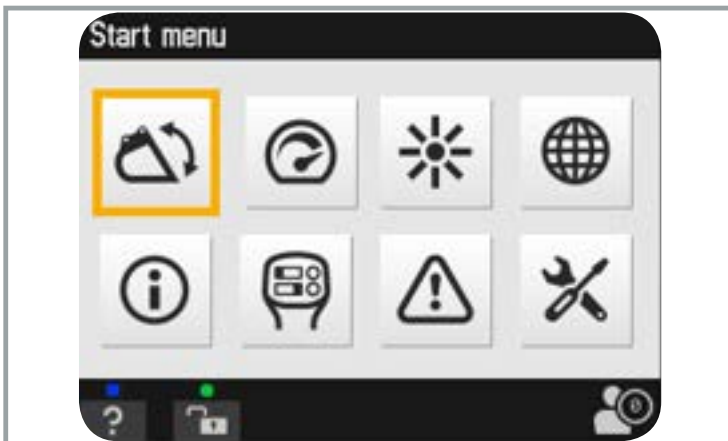

Angles

Information about rotation* and tilt angles is found via the menu and special functions can also be chosen here.

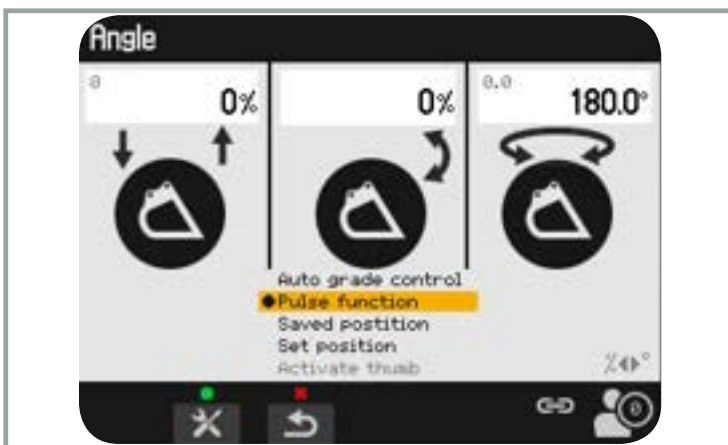

Pulse function

The shake function is active when starting the system except in those cases when the hydraulic thumb is activated. Shake the bucket by pressing and holding switch 1, left handle depressed, and at the same time, pulling roller B with the tilt function (default: roller B, right handle).

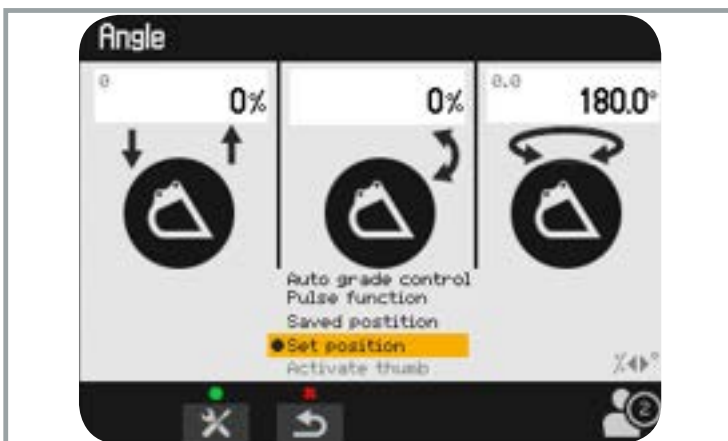

Set position*

Select the set position and press OK to save the current rotor and tilt positions in the memory for the next time the system is started.

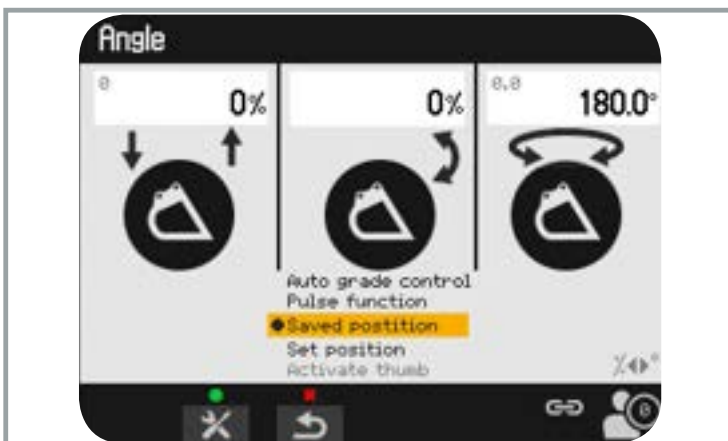

Saved position*

Select saved position and press OK. When switch 1, left handle is activated the rotor and tilt functions move to the saved, predefined positions. The function is only active in this view.

**Does not apply to ICS Basic.*

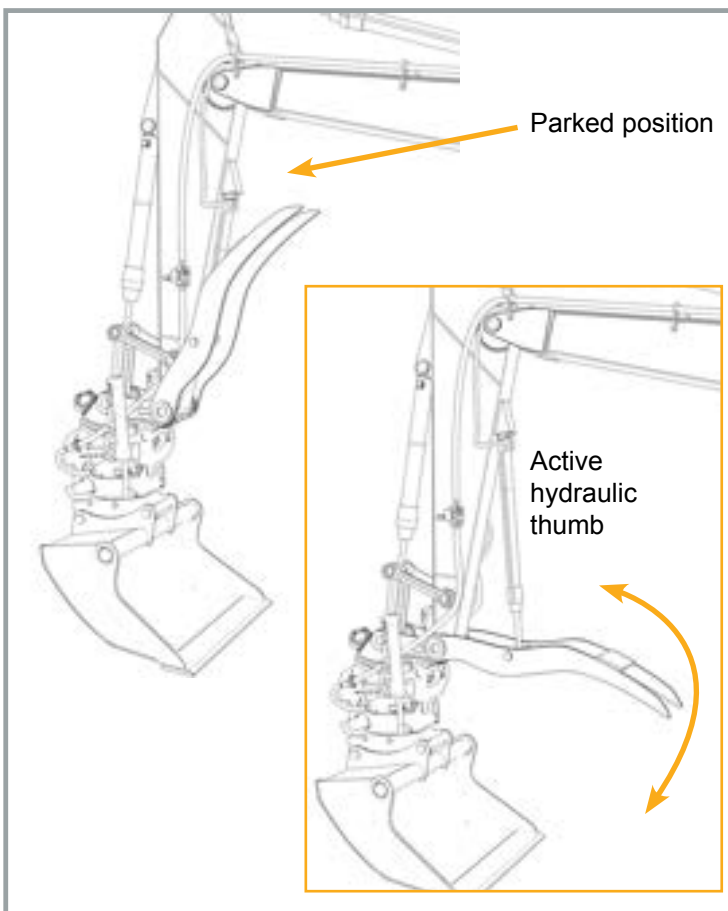
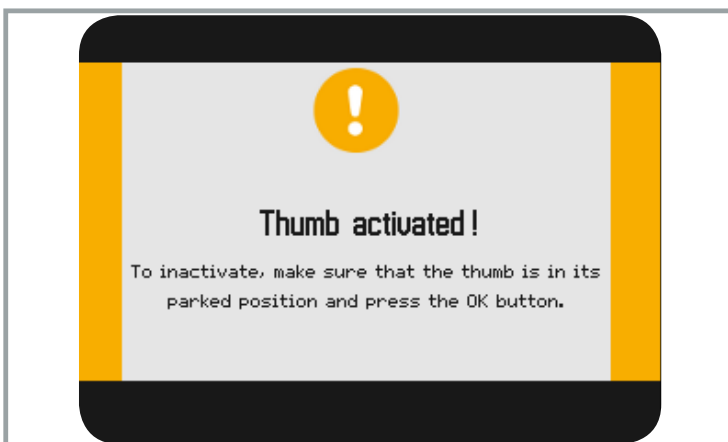
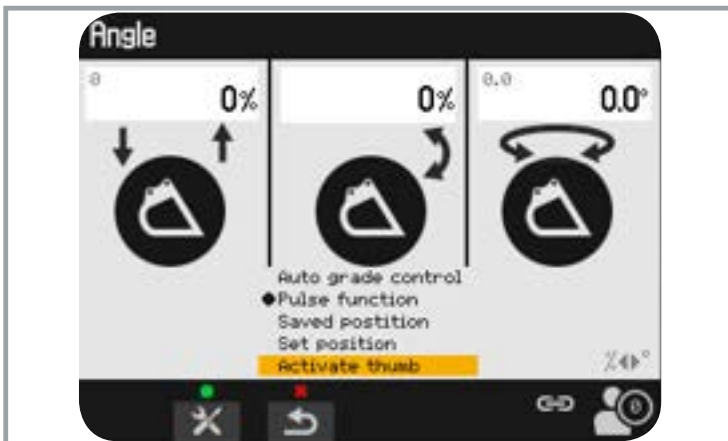

Hydraulic thumb

If the base machine/excavator is equipped with a hydraulic thumb on the stick, the ICS system can prevent simultaneous use of the tiltrotator and hydraulic thumb.

The display shows the alternatives under the Angles menu. If the text is grey instead of black, the function cannot be activated.

To activate this function, the tiltrotator's rotation position must be at the zero position; a certain margin of error ($<5^\circ$) is allowed.

The angle of the tiltrotator in relation to the base machine/excavator shaft shall be 0° . Perform a visual check to ensure that this is the case.

Select the alternative and confirm with OK.

As long as the hydraulic thumb is activated, a warning text is shown on the display.

Disabling the function must be done manually. It does not shut down in connection with system restarts or when the base machine/excavator ignition is turned on and off.

Before disabling the function, the hydraulic thumb must be returned to the parked position. Perform a visual check to ensure that this is the case.

Turn off the function with OK.



Automatic Grade Control

Option only available with activated RPS and established communication with excavator system.

If the automatic tilt and rotation function is included in the installed excavation system, it can be controlled via ICS.

Select the icon for the Angles menu and then confirm your selection with OK.

Select Auto grade control (AGC) in the view on the display using the arrow keys.

Confirm your choice with OK.

Activate the function by pressing and holding the button on the handle. This is generally located on the right handle; check against the handle sticker.

The function is only active in this view.

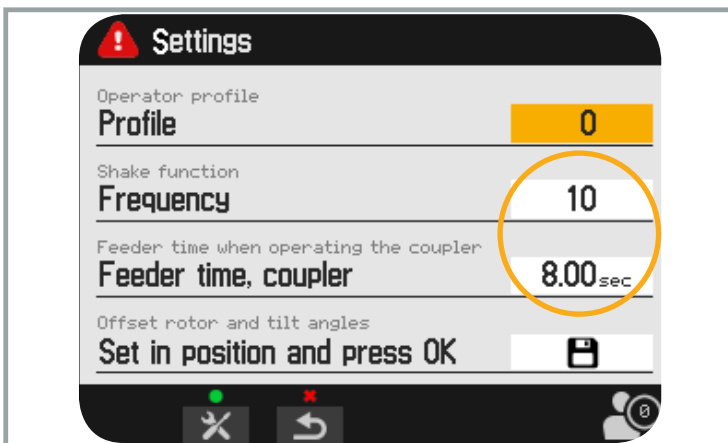

Shake function/Frequency

Select Frequency and adjust the frequency of the shake function.

Pressurising

Select Feeder time Coupler and set the required value (3-12 sec). The saved value regulates the time that the quick coupler locking function is pressurised.

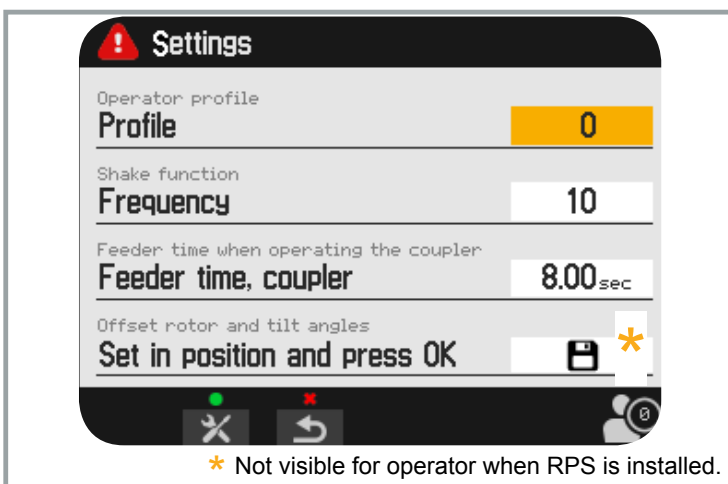

Calibrate angles

In order for the angle display to work correctly, it must be calibrated with the right bucket.

Rotate the bucket to the zero position. Position the bucket bottom flat against the surface.

Now highlight the icon to save (diskette), using the arrow keys.

Confirm with the OK function key.



INFO -

If RPS is installed, angles are calibrated by an authorised installation engineer.

System information		
Serial number		000655360
Program version, Cabin	Rototilt	11.222.333
Program version, Display	Rototilt	11.222.333
Program version, Tiltrotator		01.002.003
Supply voltage	Cab	0.0V
	Tiltrotator	0.0V
Time		12:42
Date		2016-10-01
Hours counters		
	Power on	0:08
	Rotor	0:00
	Tilt	0:00
	Grapple	0:00
	Extra2	0:00

System Information

Serial number - The tiltrotator's specific number, also found on the rating plate.

Software version - Shows the version number for the software of each unit, display, CCI and TCU.

Supply Voltage - Power supply to the control unit and tiltrotator.

Time - Current time. Select the row and then press the middle function button (green) to set the time.

In some cases *Bat Clock* is not connected, which results in the system losing the time and date setting.

Date - Current date.

Hours counters - Shows the total hours of operation for the tiltrotator, and the total hours of operation for each function.

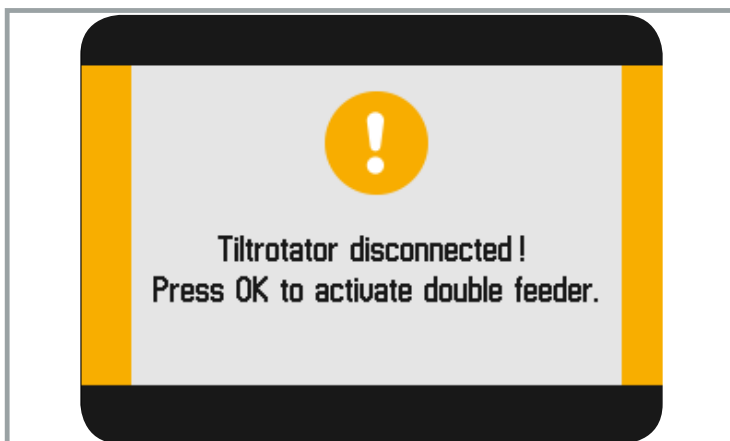

Double feeder

The Double feeder mode can be activated after Rototilt® has been disengaged.

The function is either controlled with roller B, or with switches 1 and 2.

Activate control with the switch via the Angles menu.

"On/off Double Feeder" must be confirmed with OK.

The function is only active in this view.

See *Operation of extra hydraulics*.

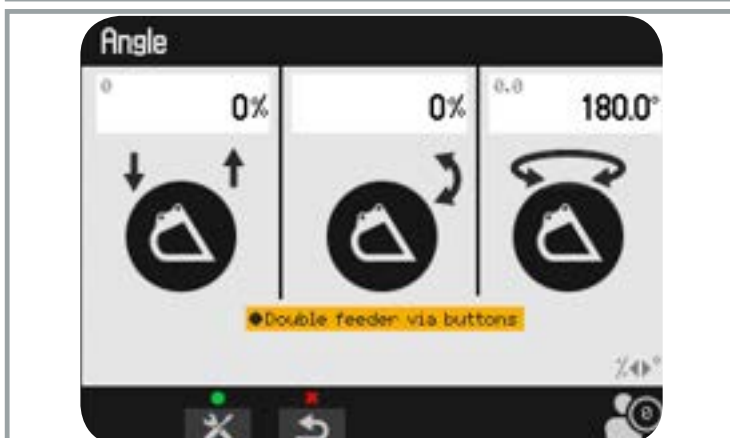

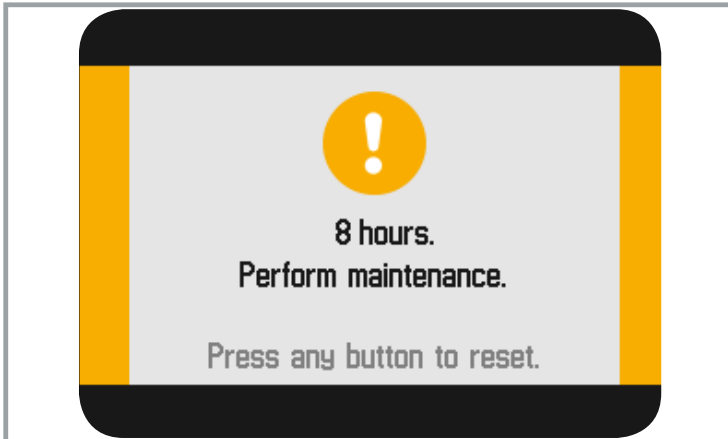

Reminder service

The system shows a reminder, after every 8 hours of operation. The reminder indicates that requisite service must be carried out.

If the ILS option is specified, the reminder for the 8-hour interval is automatically switched off.

See the *Rototilt®* user manual

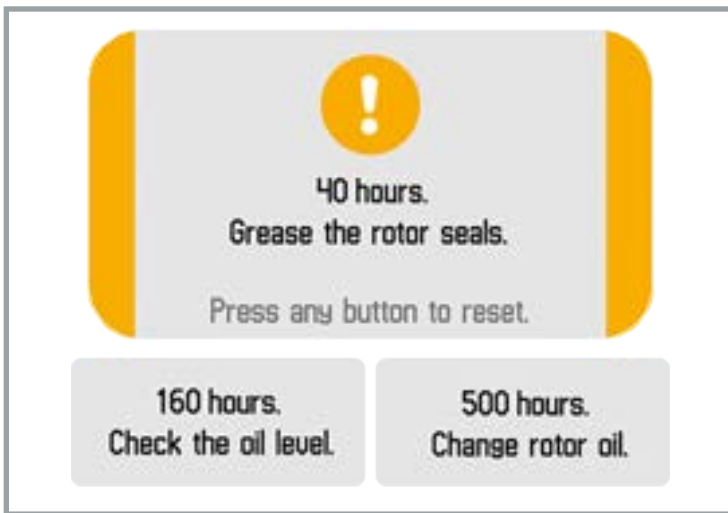

Reminder, other interval

The system also shows reminders for every 40th, 160th and 500th hour of operation.

See the *Rototilt®* user manual



IMPORTANT - Detailed information about the measures to be performed at each interval can be found in the user manual for the tiltrotator. Interval: "Daily inspection" and "8th hour of operating" refer to different service points.

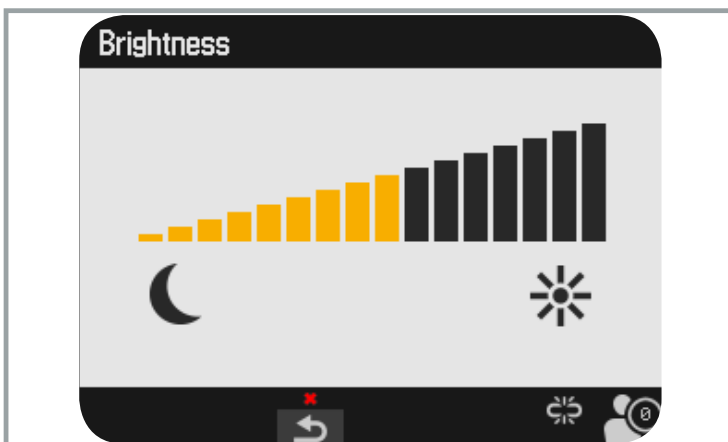

Brightness

The display brightness is adjusted with the arrow keys.

Confirm with OK.

Troubleshooting ICS

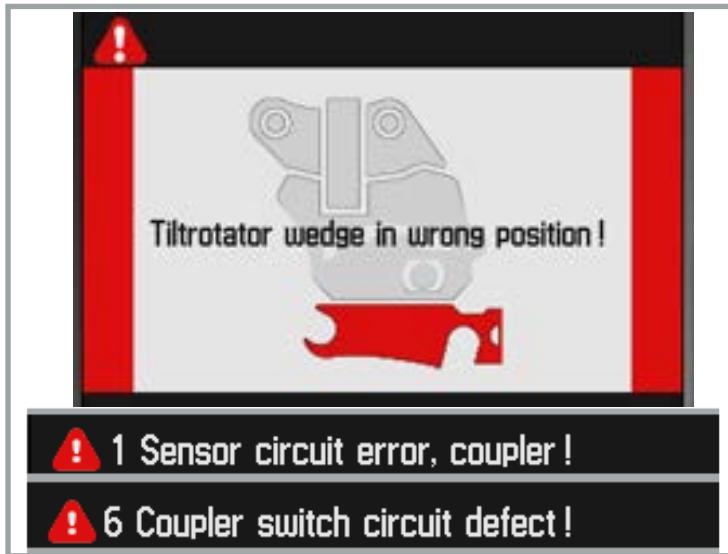

Active alarms

Can be shown on the display either with a complete picture or as text on the upper bar.

The numbering of alarms on the upper bar is the same regardless of language.

Go to the Troubleshooting menu for detailed information.



Troubleshooting

The menu has three levels: Current alarm, Historical alarm and Alarm log.

Press the middle function button (green) to move through the levels. Use the right function button (red) to go back.

Detailed information:

Select current alarm

Confirm with OK.

The information is displayed in display.

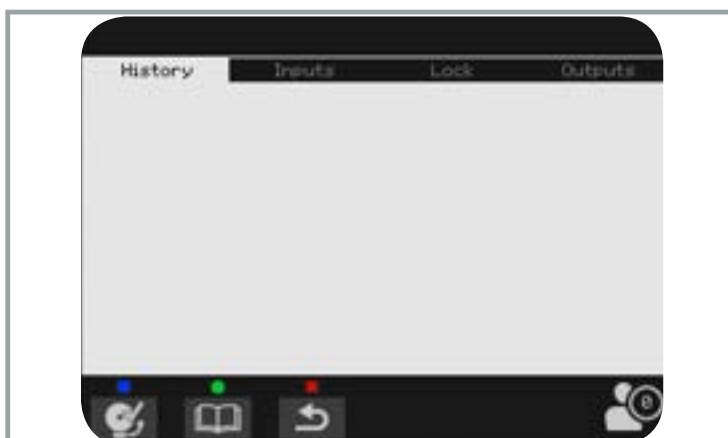

Historical alarms

Previous alarms can be read on the historical alarms submenu. The operator can delete this list. Press the left function key (blue) to delete.

Alarm log

All alarms are also saved in a log.

This entries cannot be deleted.



Input signals

The menu shows information about the input signals to rollers, shut-off levers and switches.

A non-calibrated roller is red and shows voltage (V) instead of percent (%).



Output signals

The menu shows the current for each output signal.

Use the arrow keys to see the full list.

i INFO - When the shut-off lever is deactivated, no movement is shown at the outputs.

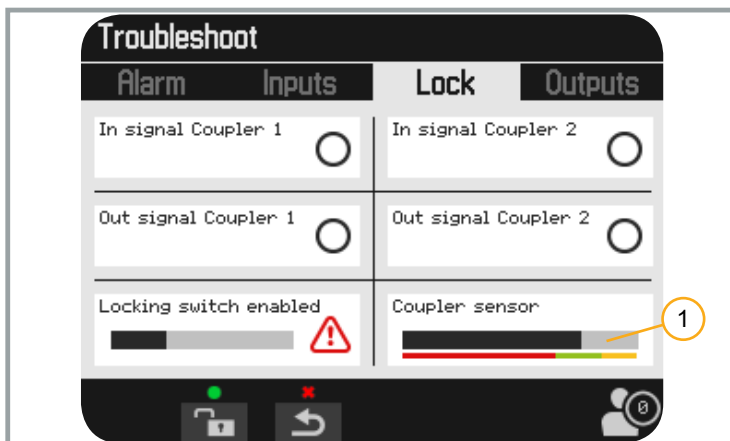

Quick coupler locking function

The menu shows information about input and output signals to the lock circuit.

It is possible to activate the lock using the middle function key (green).

Also refer to “*Detach the tool*” in the user manual.

When the lock switch is active the two upper circles are green.

When the valve solenoids are active the two lower circles are green.

The location of the locking wedge is shown with a black bar against a red-green-yellow scale.

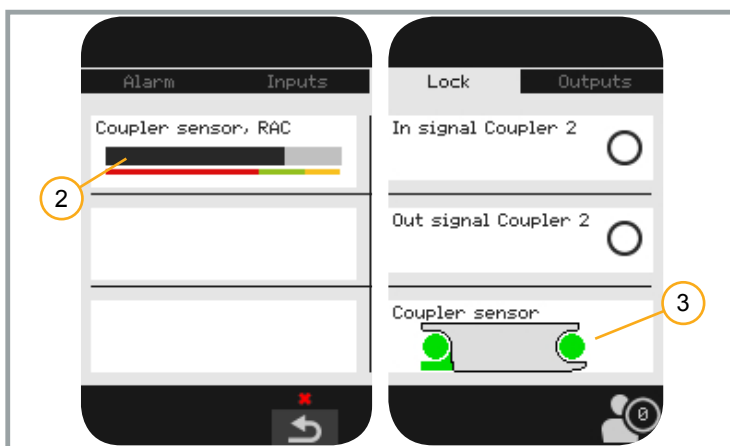

1. *Coupler Sensor* concerns the quick coupler’s locking wedge.

2. *Coupler Sensor, RAC* concerns the machine coupler/quick coupler (excavator) locking wedge.

3. If the tiltrotator is equipped with the option QuickChange™, the quick coupler is shown with an alternative icon; see *Coupler Sensor*.

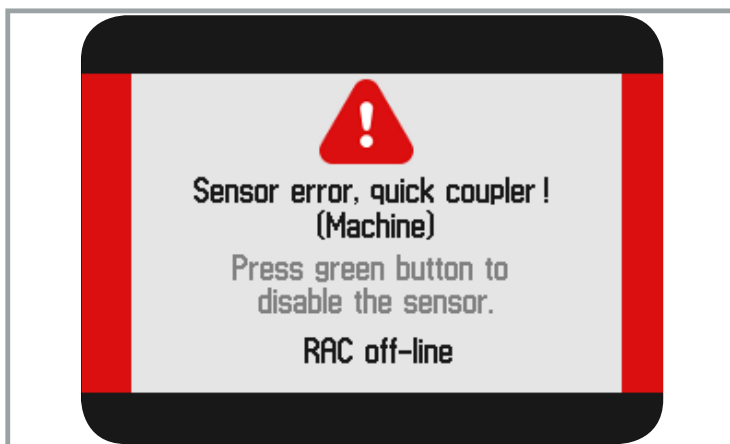

Troubleshooting of machine coupler

Communications error

The message RAC offline indicates a communications error on the CAN bus. The warning is shown both for errors on the CAN bus and in event of a power failure.

Sensor failure

The message indicates a sensor error in the machine coupler/quick coupler (excavator).

The value of the current voltage is helpful when troubleshooting.

Values close to 0 V indicate a short-circuit to earth.

Values close to 5 V indicate a short-circuit to the supply.

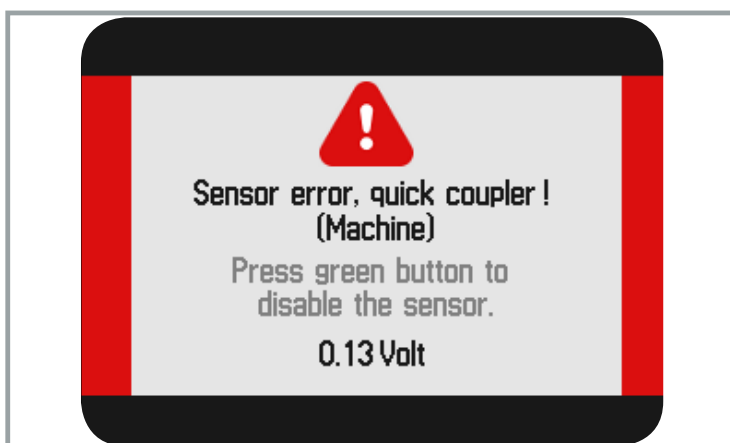

Detailed troubleshooting of machine coupler/quick coupler (excavator); see *the user manual for the machine coupler*.

Troubleshooting QuickChange™

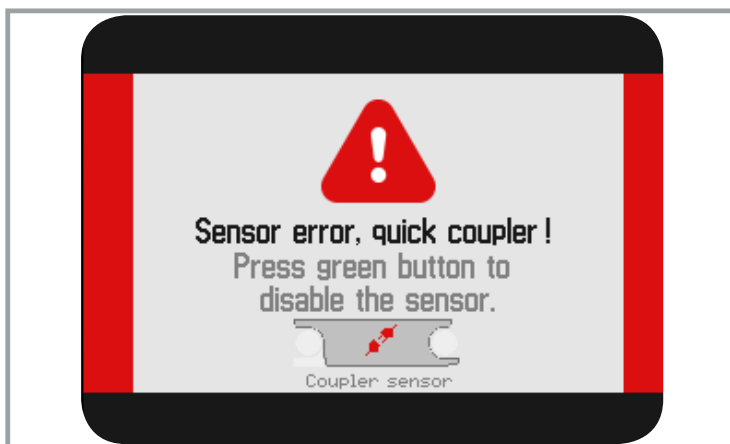
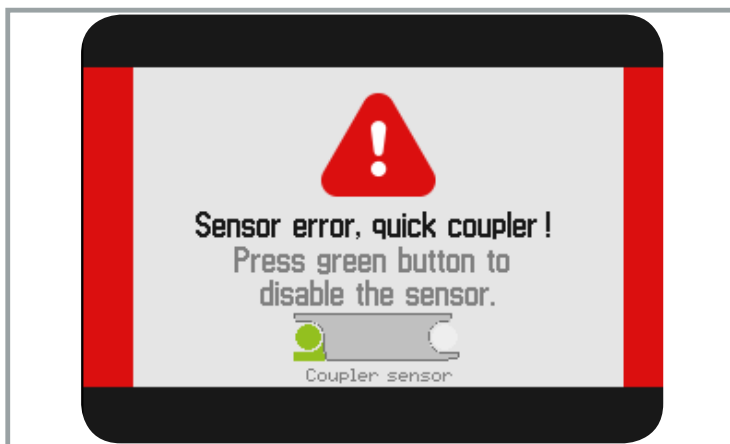
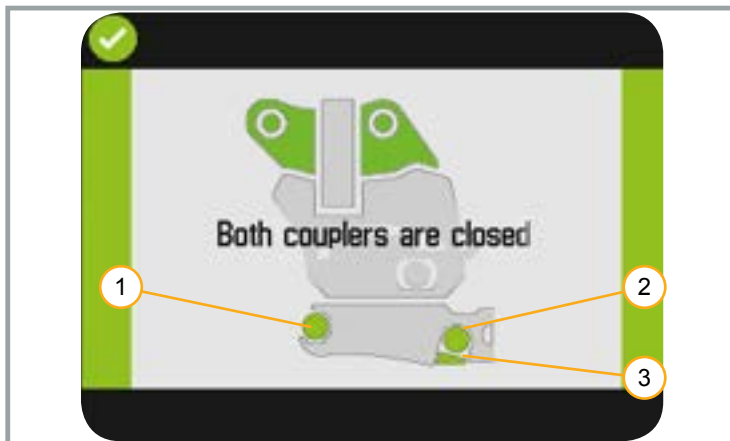

QuickChange™ is equipped with 3 inductive sensors, one per shaft and one for the locking bolts.

These are monitored continually and must therefore be engaged in a specific order. If the order changes a sensor fault is indicated.

If the lock switch is returned to the closed position before the system has verified that the tool is in position, a sensor fault is indicated. Wait a further half second to return the switch to the closed position. All sensor faults are accumulated until the control system is restarted.

When closing the coupler, the first shaft (1) is engaged, followed by shaft (2) and finally the locking bolts (3) *see figure*.

Sensor faults are indicated if the tool is engaged in the wrong order.

Sensor faults are indicated during operation if the control system loses contact with any of the sensors or the CAN bus.

Faults can occur due to three reasons.

1. Sensor fault.
The warning can be acknowledged with the green function button. Check whether this is a temporary or a permanent fault. If the fault remains after a restart it is a permanent fault. Contact support. *see figure*
2. Operation.
See the above
3. CAN bus fault.
Contact support

The hydraulics in QuickChange™ must be protected from external damage and dirt. Do not leave the quick coupler open.

If the locking bolts are retracted when the base machine/excavator is switched off, the text "wedge in wrong position" is shown during start-up.

Extend the locking bolts, and QuickChange™ can then be used.

Schematics

Schematics and Overviews for hydraulic as well as electrical systems, in the following pages are meant to serve mainly as a guide for Troubleshooting.

! For optimum performance and service life, return T1 must be connected to free return. To enable complete drainage via Drain, a separate return must be connected to the tank via T4.



WARNING!
More extensive adjustments and repairs must be done by an authorized service workshop.

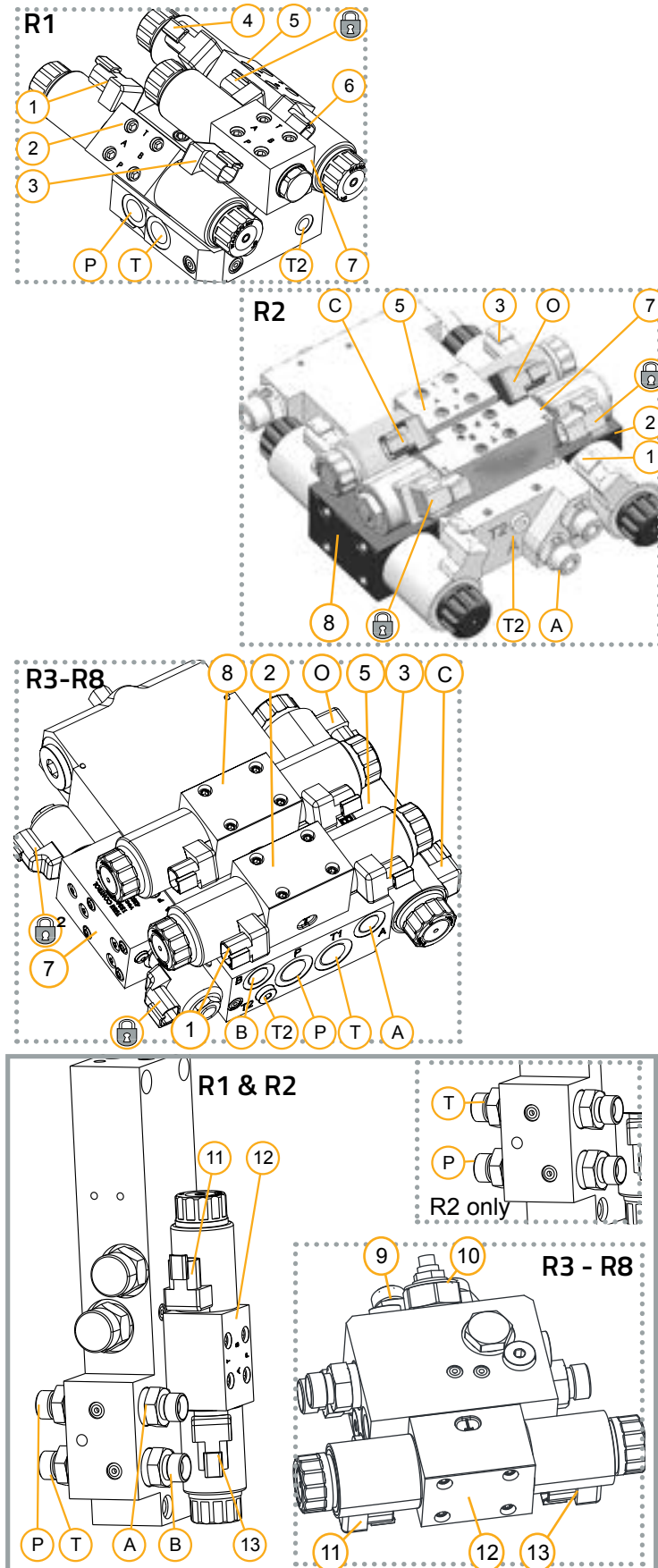

Valveblock Swivel

1. Rotation Left, connection
2. Rotation Valve
3. Rotation Right, connection
4. Extra Left, connection
5. Extra Valve
6. Extra Right, connection
- Coupler 1, connection
7. Coupler Valve
8. *Extra 2 Left, connection*
Extra 2 Valve
Extra 2 Right, connection
- Coupler 2, connection
not applicable for R1

Valveblock, Tilt

9. Pressure Reducing Valve
10. Check Valve
11. Tilt Left, connection
12. Tilt Valve
13. Tilt Right, connection

Remaining connections

- A. Circuit A, connection
- B. Circuit B, connection
- C. Close
- O. Open
- P. Pump, connection
- T. Return to Tank, connection
- T2. Return to Tank from Coupler
Only X-systems
- T4. Drain, connection

Hydraulics Schematic ICS Basic R1

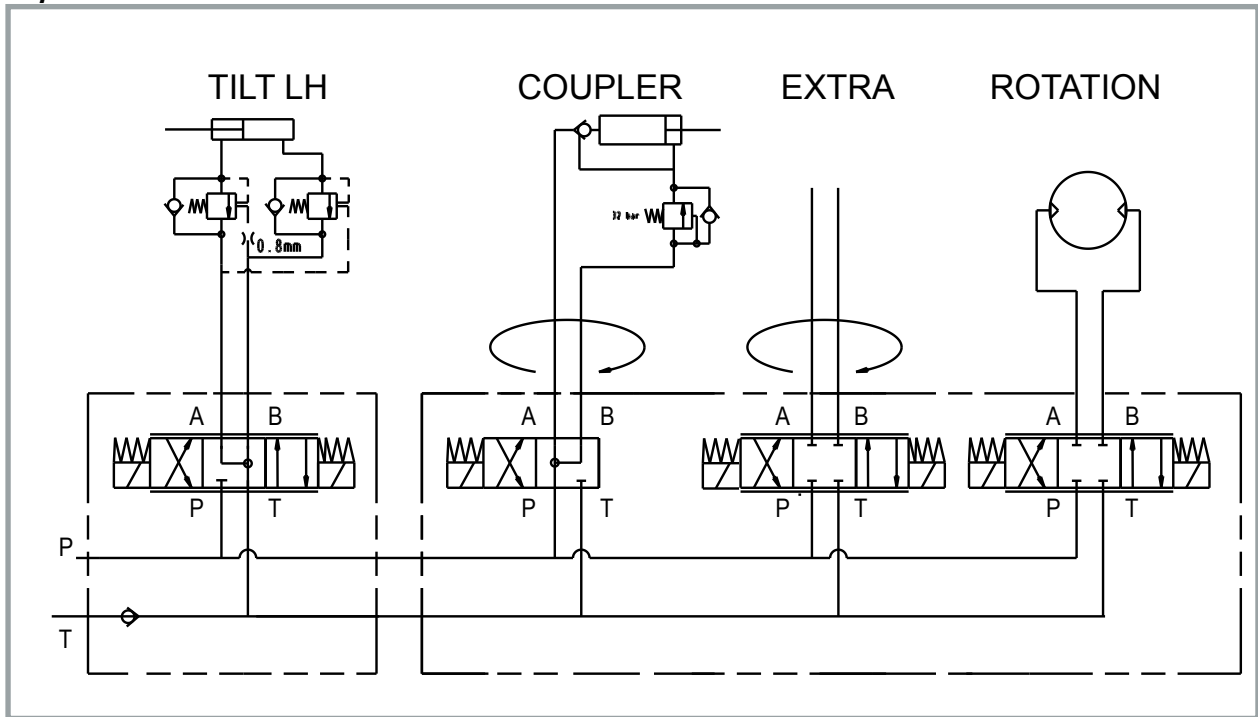

Hydraulics Schematic ICS X R1

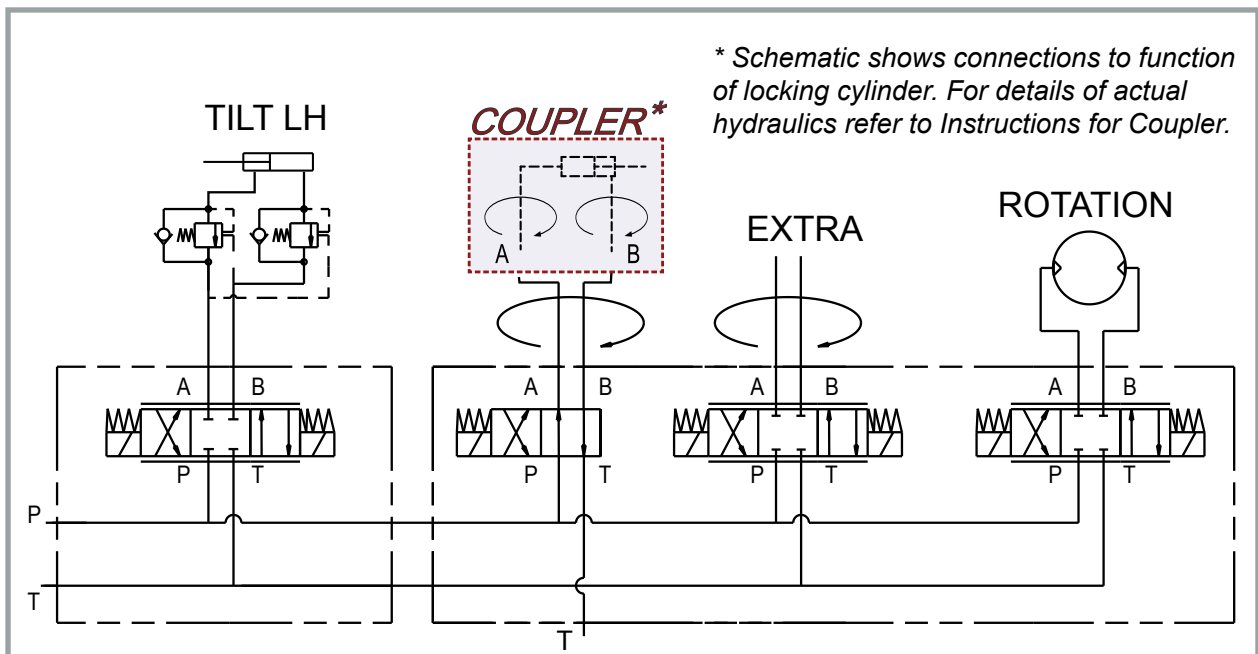

IMPORTANT!

Connection T2 should be connected to a non-pressurized separate return line, directly connected to the tank.

Hydraulics Schematic ICS 2 Extra Rototilt® R2

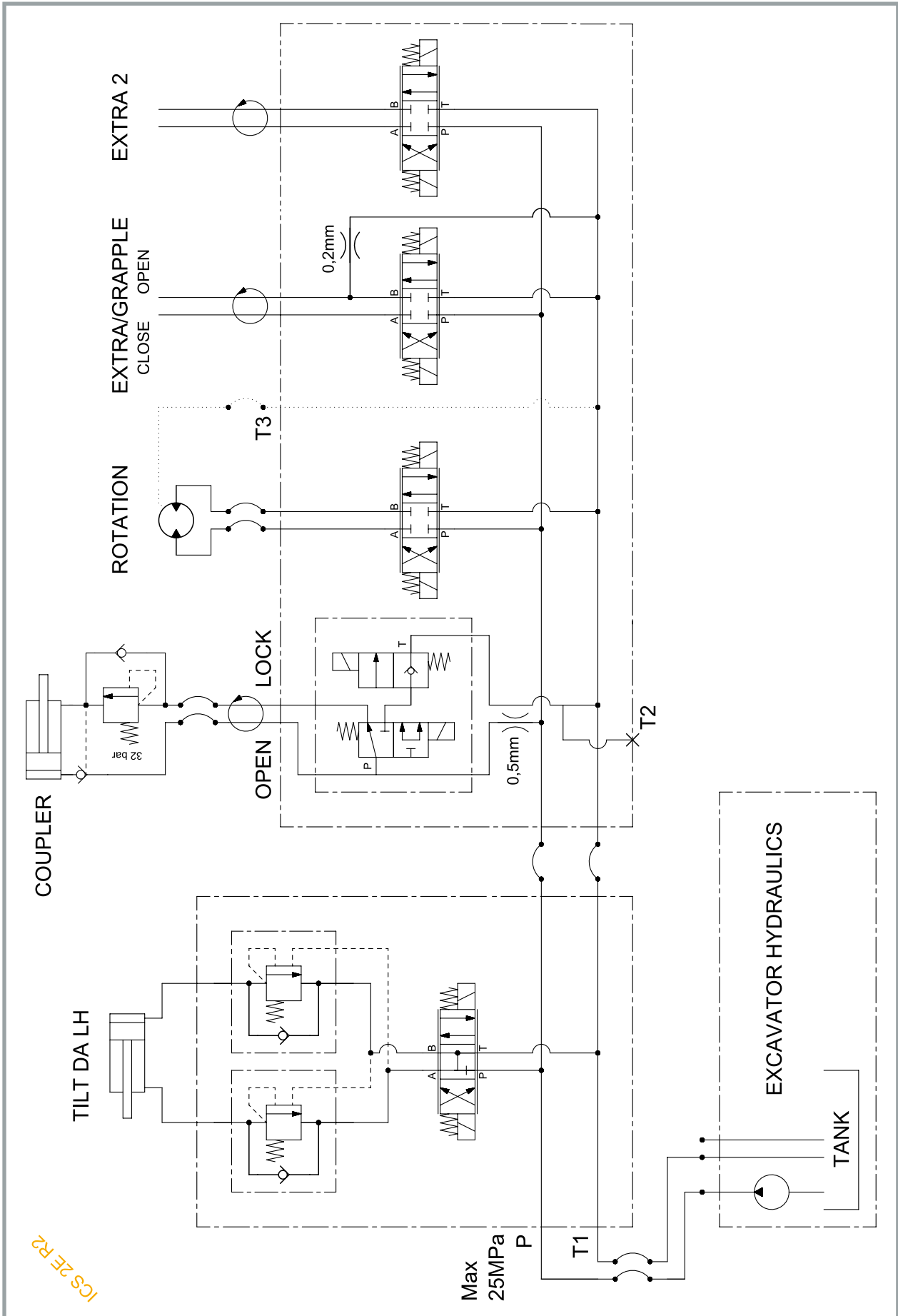

ICS 2E R2

Hydraulics Schematic ICS Basic Rototilt® R3

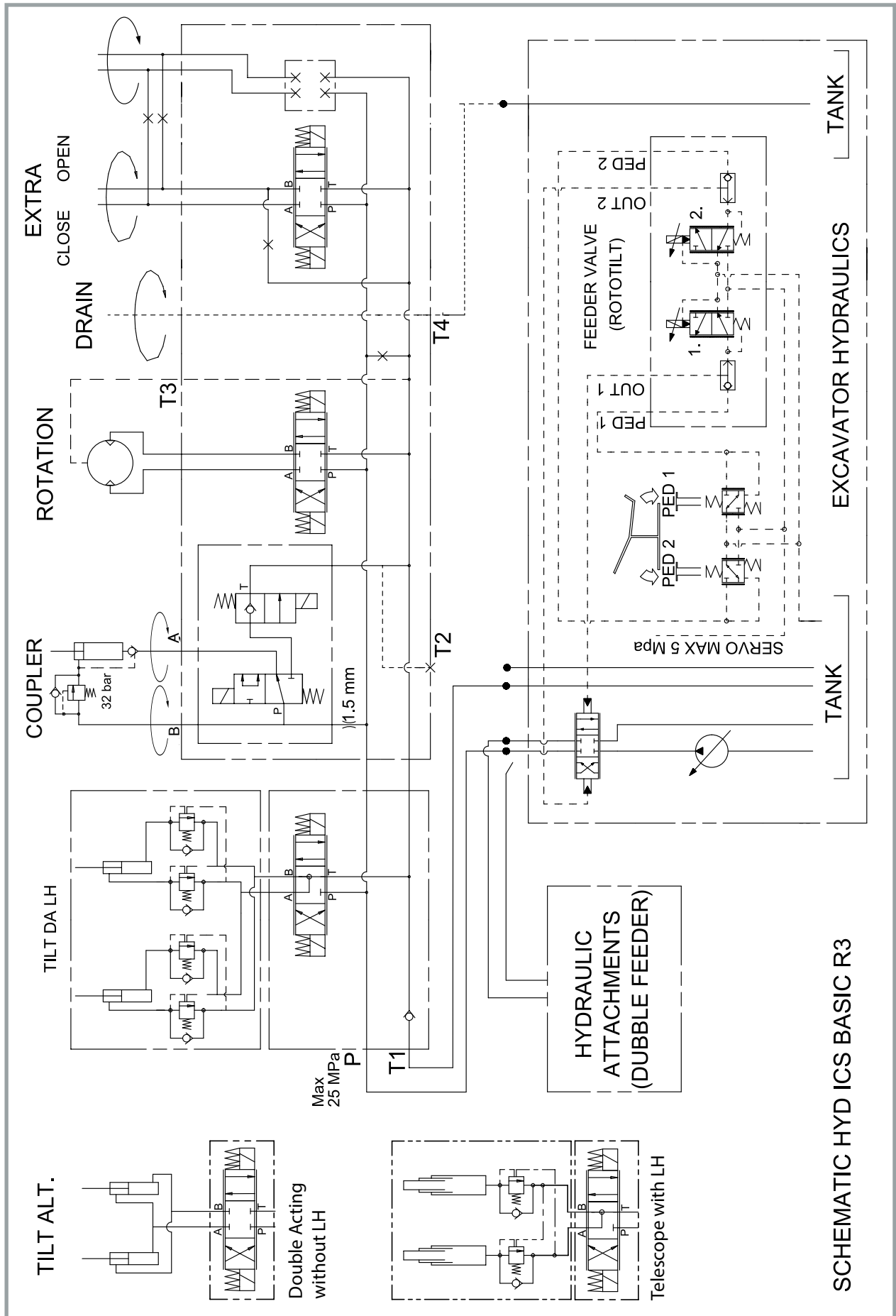

Hydraulics Schematic ICS Basic Q & X Rototilt® R3

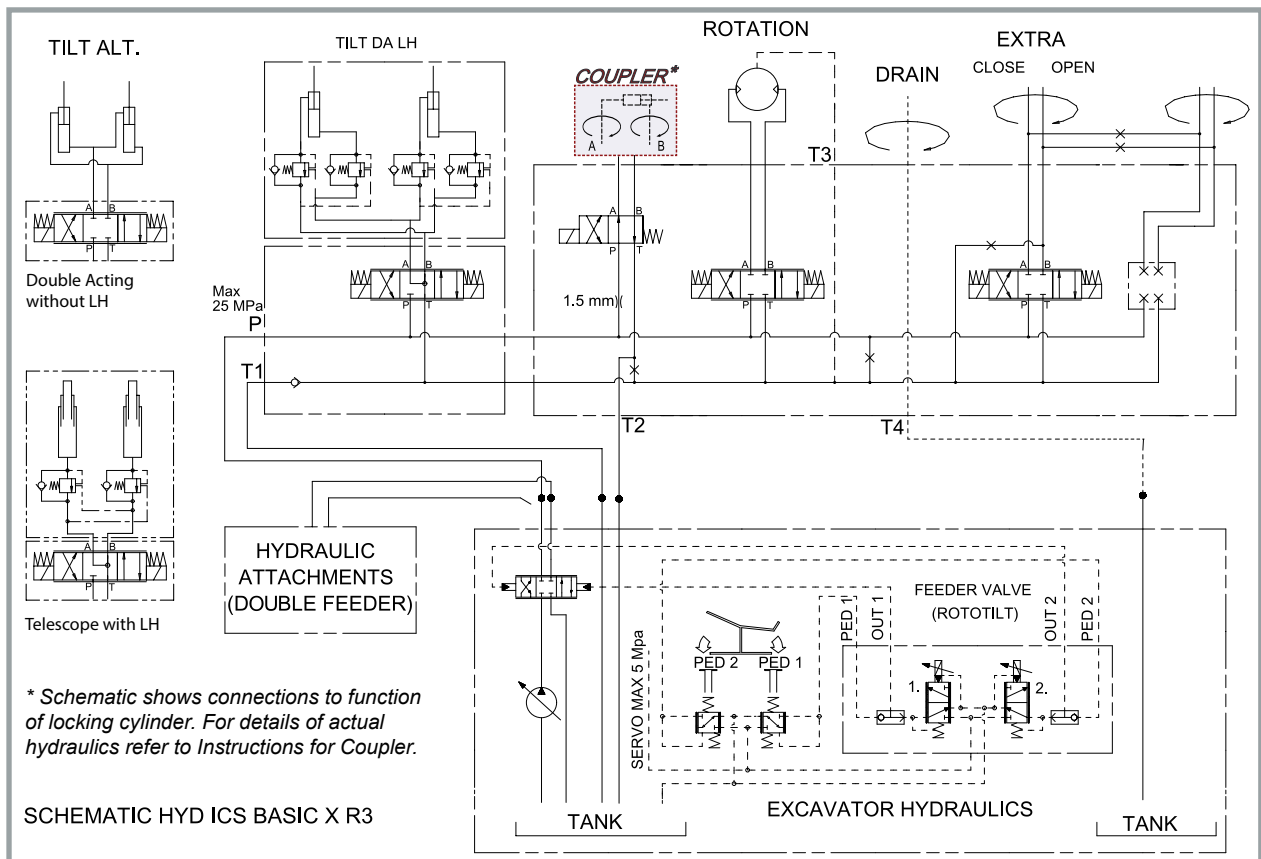
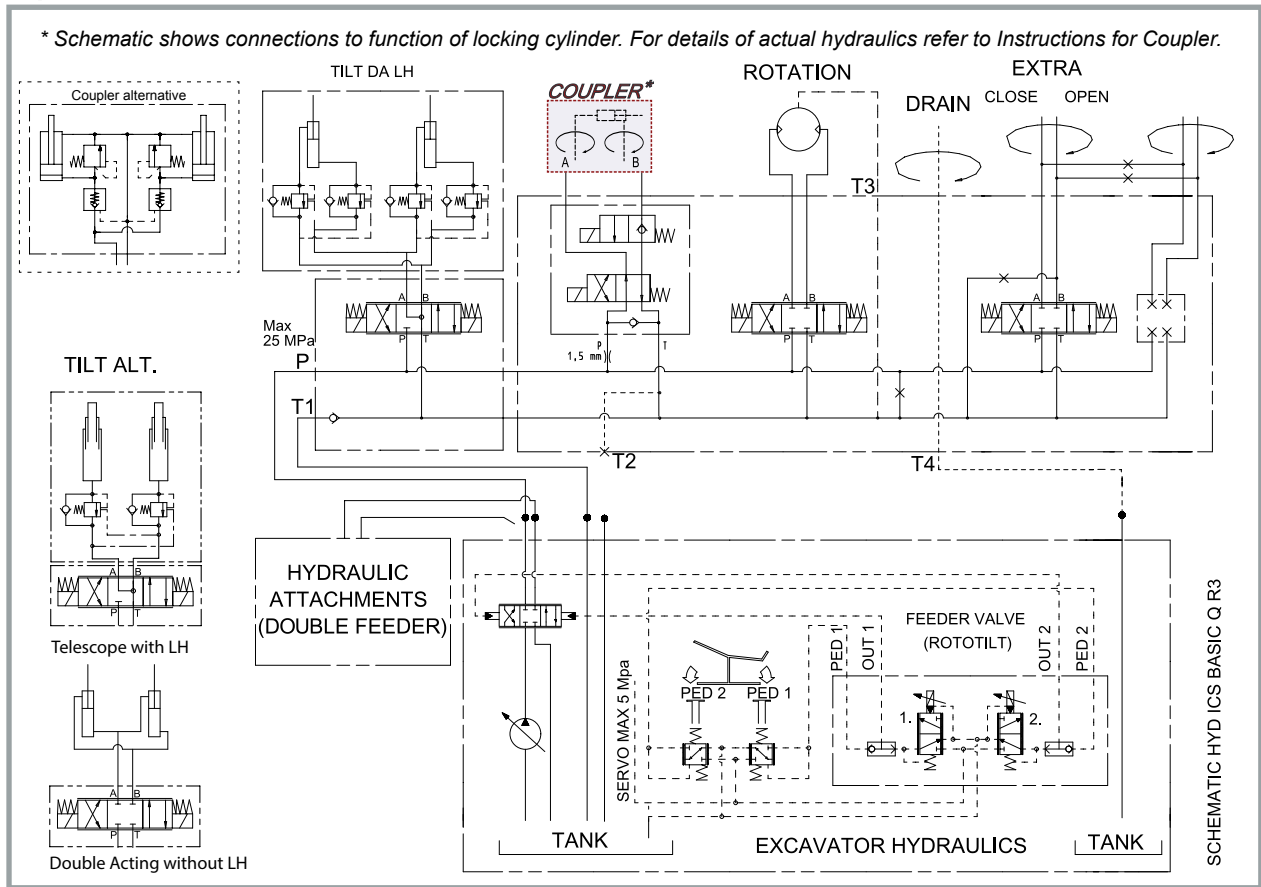

! **IMPORTANT** - Connection T2 must be connected to a separate, non-pressurized return line, directly connected to the tank.

Hydraulics Schematic ICS High Flow Rototilt® R3

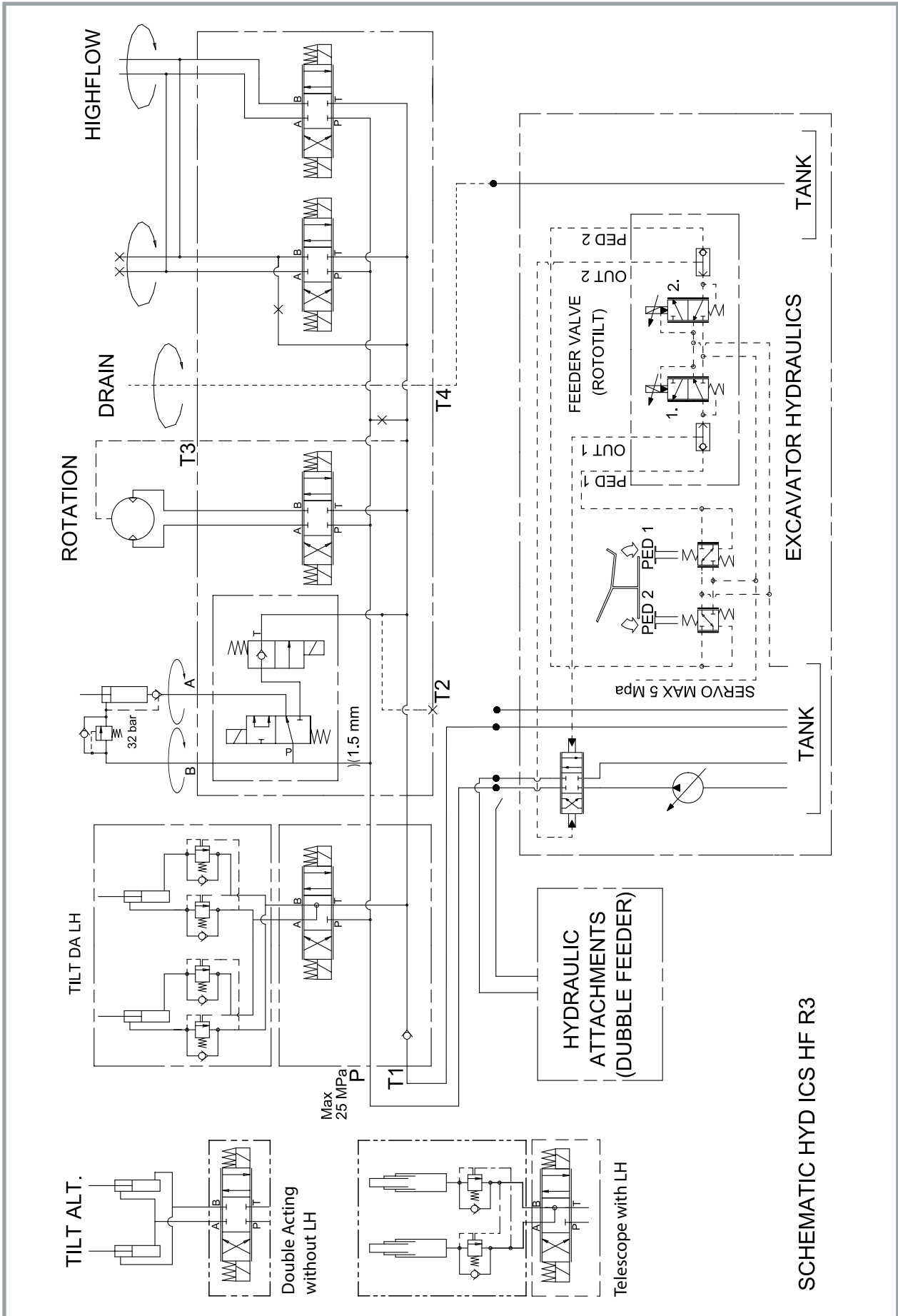

Hydraulics Schematic ICS High Flow Q & X Rototilt® R3

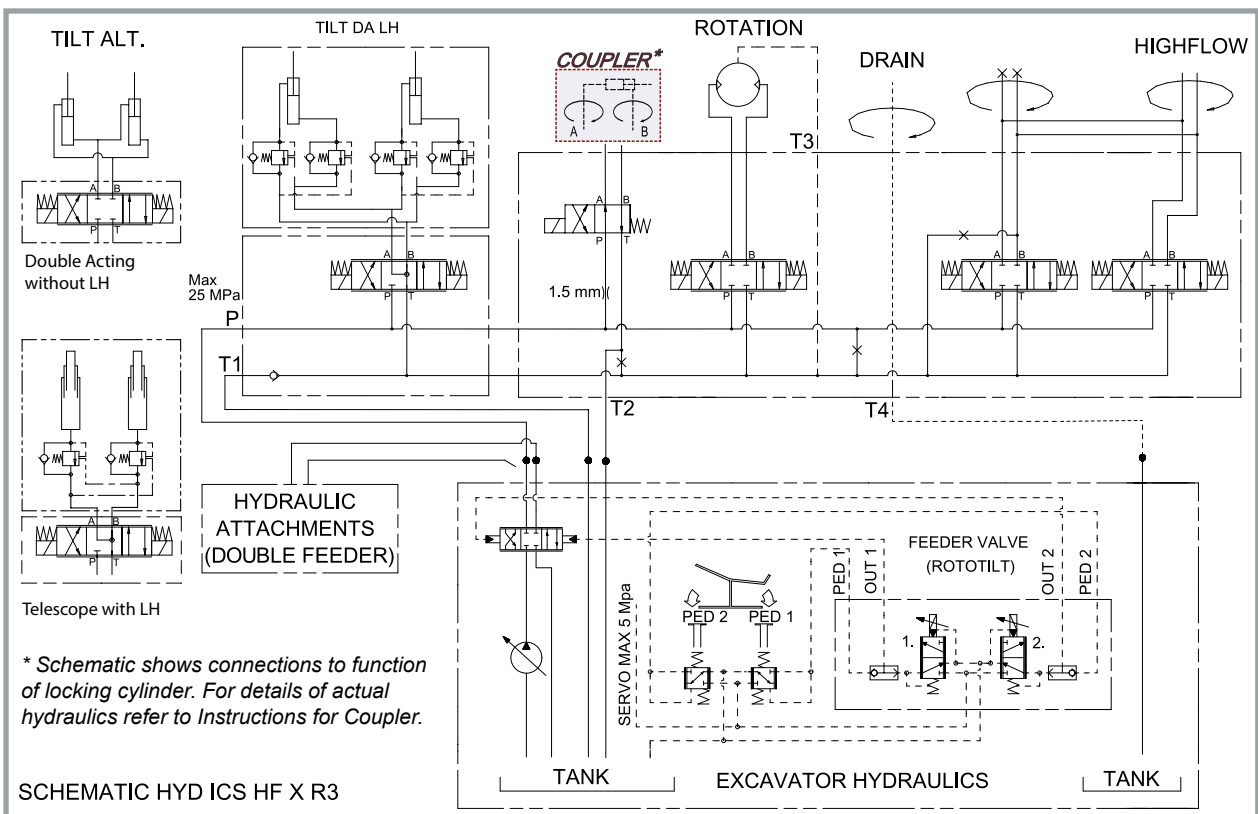
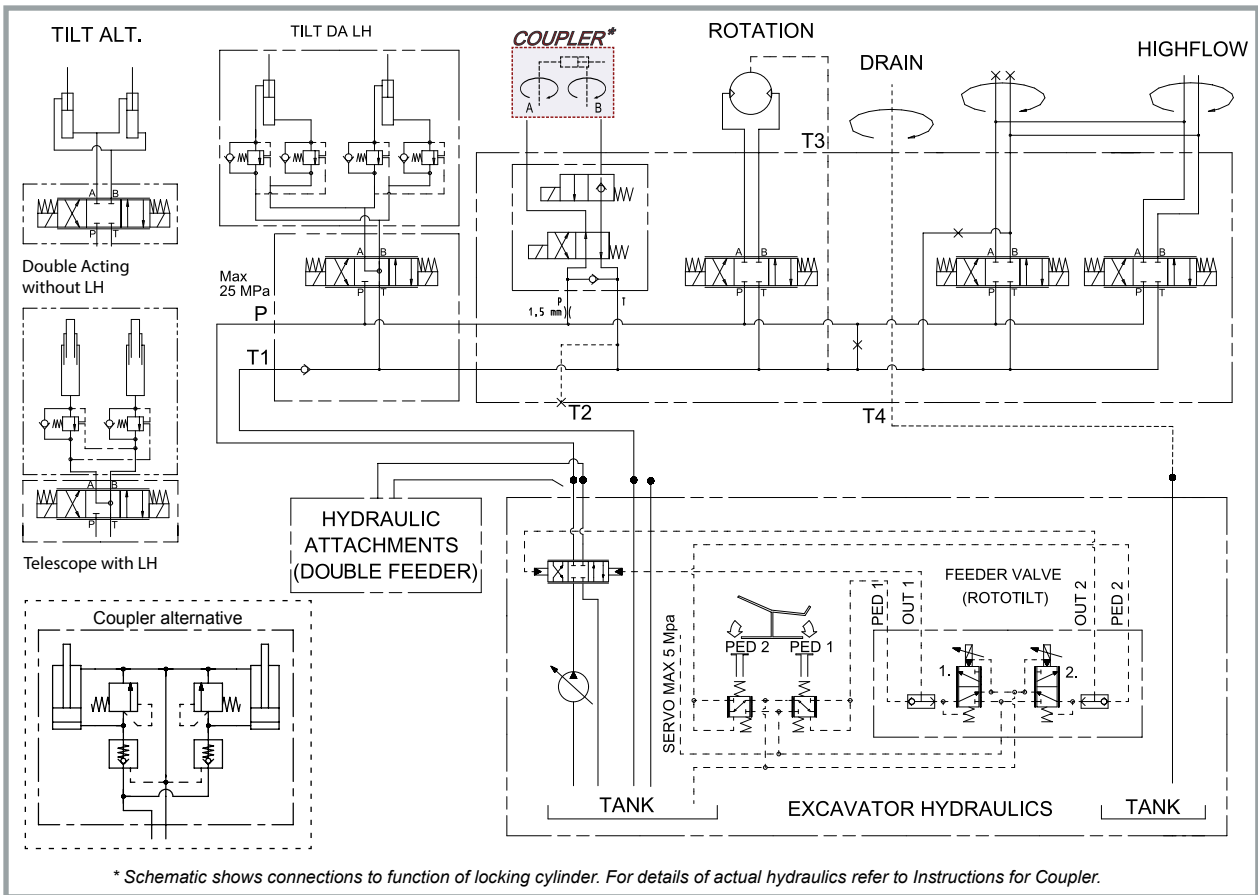

IMPORTANT - Connection T2 must be connected to a separate, non-pressurized return line, directly connected to the tank.

Hydraulics Schematic ICS 2 Extra Rototilt® R3

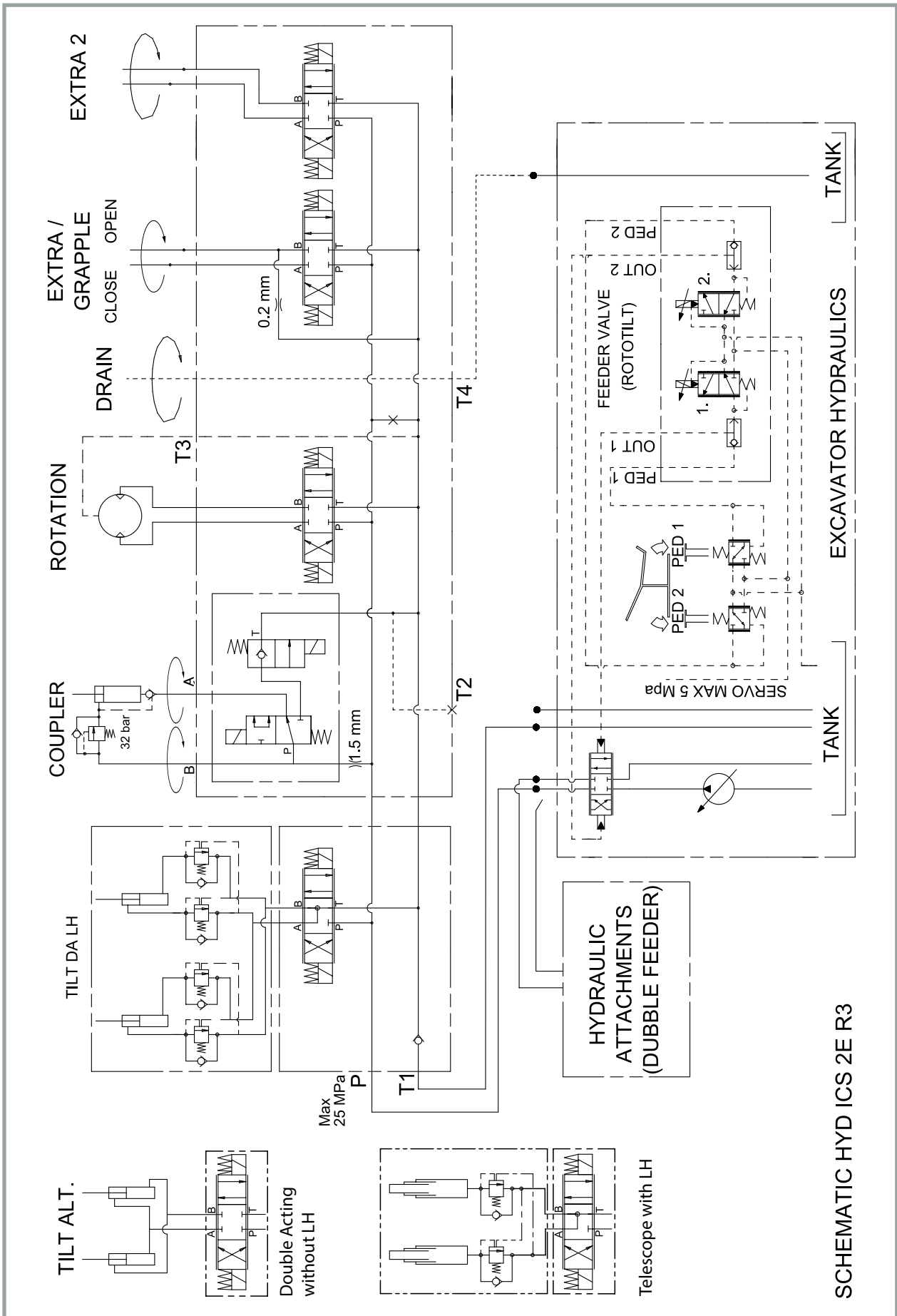

Hydraulics Schematic ICS 2 Extra Q & X Rototilt® R3

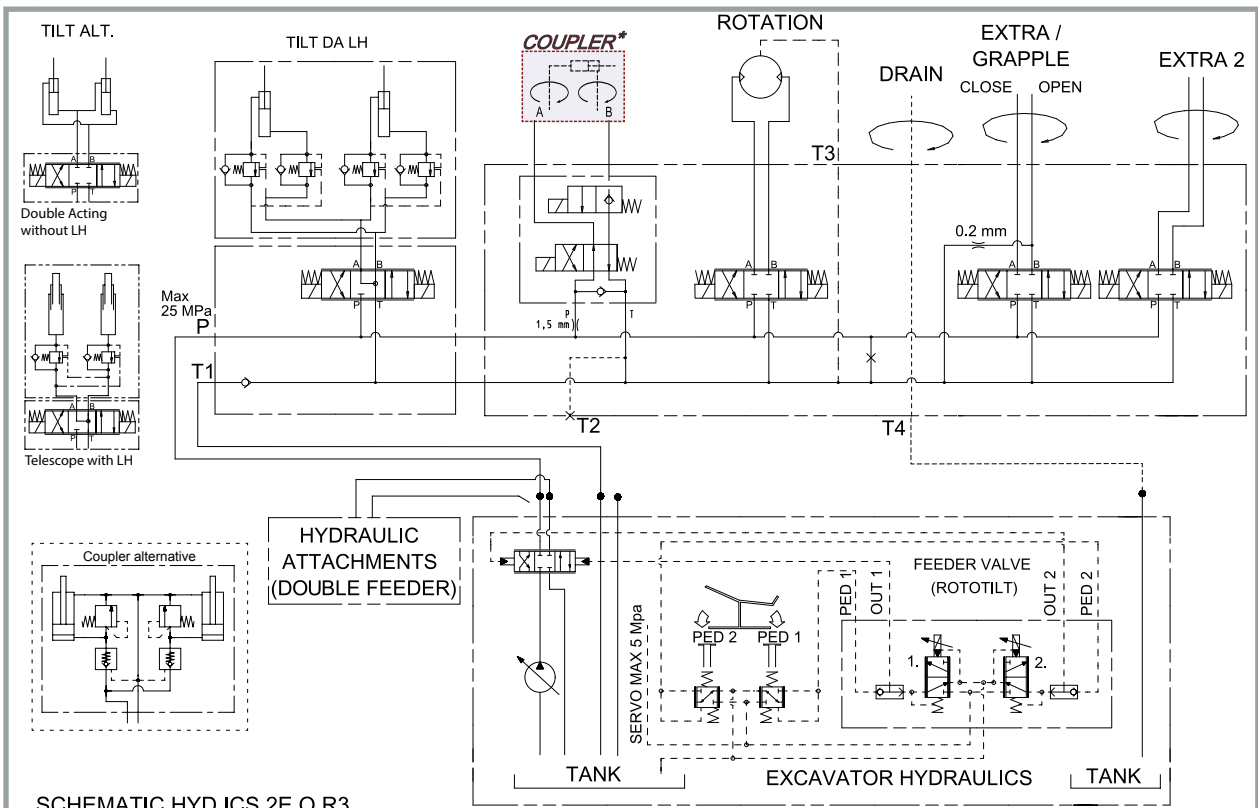

SCHMATIC HYD ICS 2E Q R3

* Schematic shows connections to function of locking cylinder. For details of actual hydraulics refer to Instructions for Coupler.

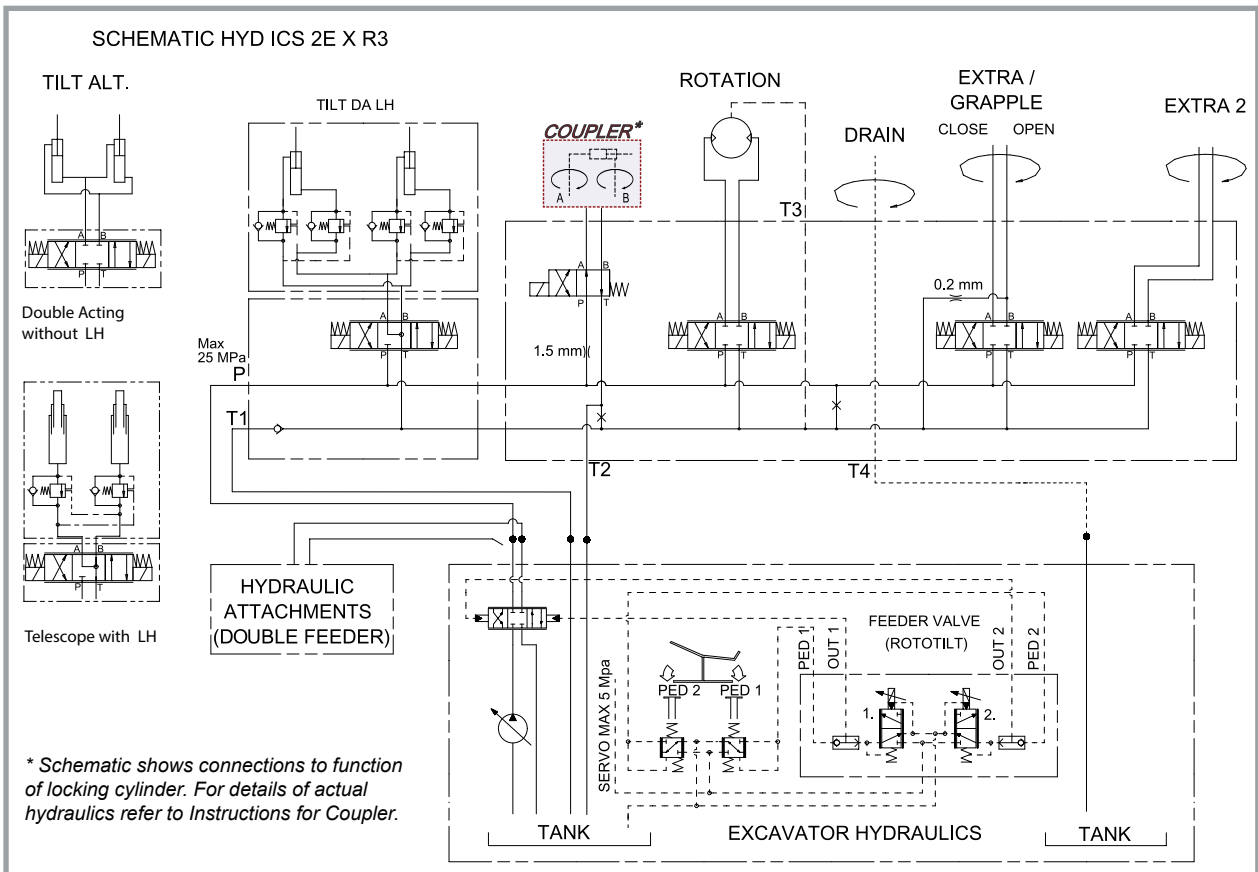

SCHMATIC HYD ICS 2E X R3

* Schematic shows connections to function of locking cylinder. For details of actual hydraulics refer to Instructions for Coupler.



IMPORTANT - Connection T2 must be connected to a separate, non-pressurized return line, directly connected to the tank.

Hydraulics Schematic ICS Basic Rototilt® R4 - R8

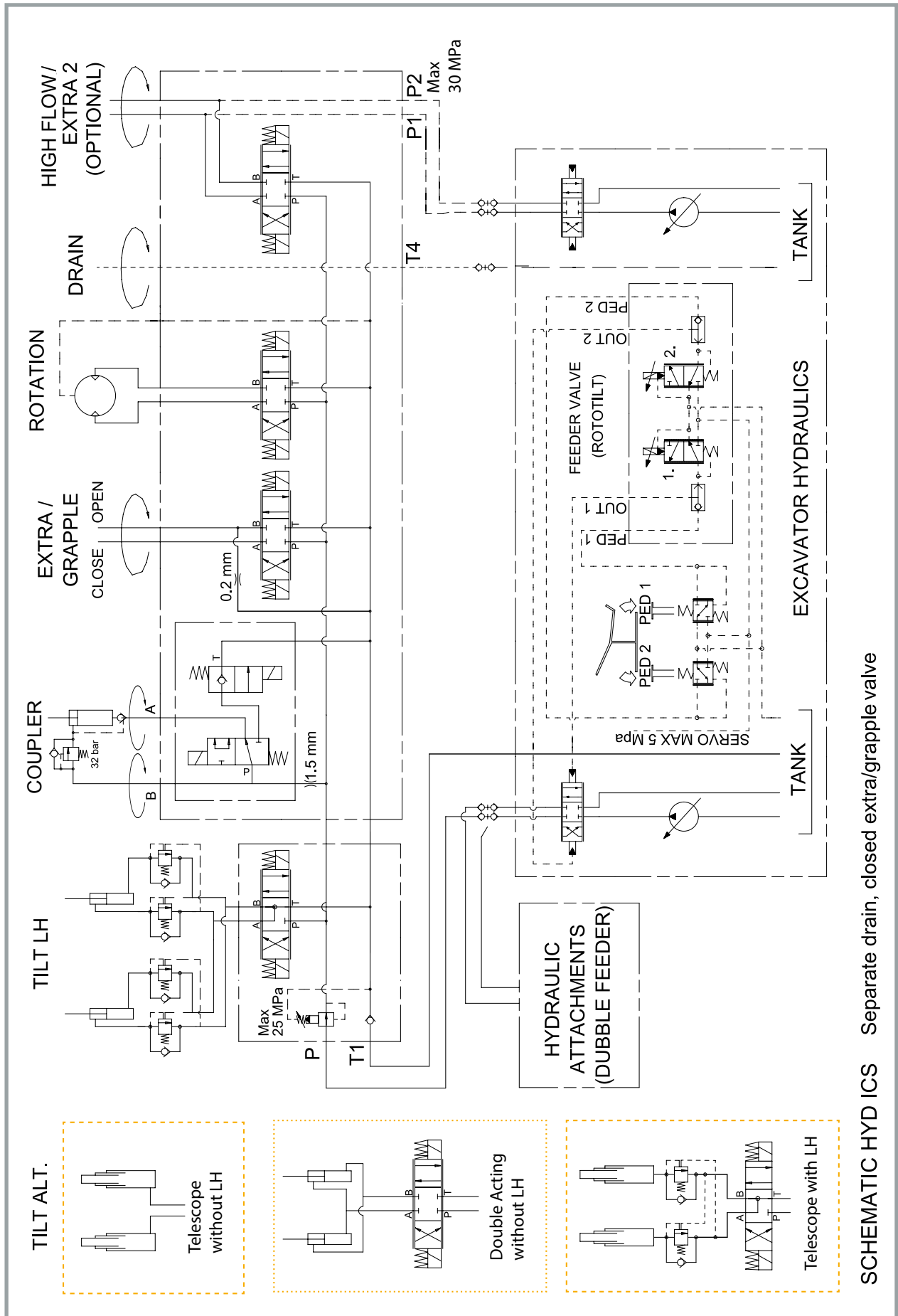

SCHEMATIC HYD ICS Separate drain, closed extra/grapple valve

Hydraulics Schematic ICS Basic Q & X Rototilt® R4 - R8

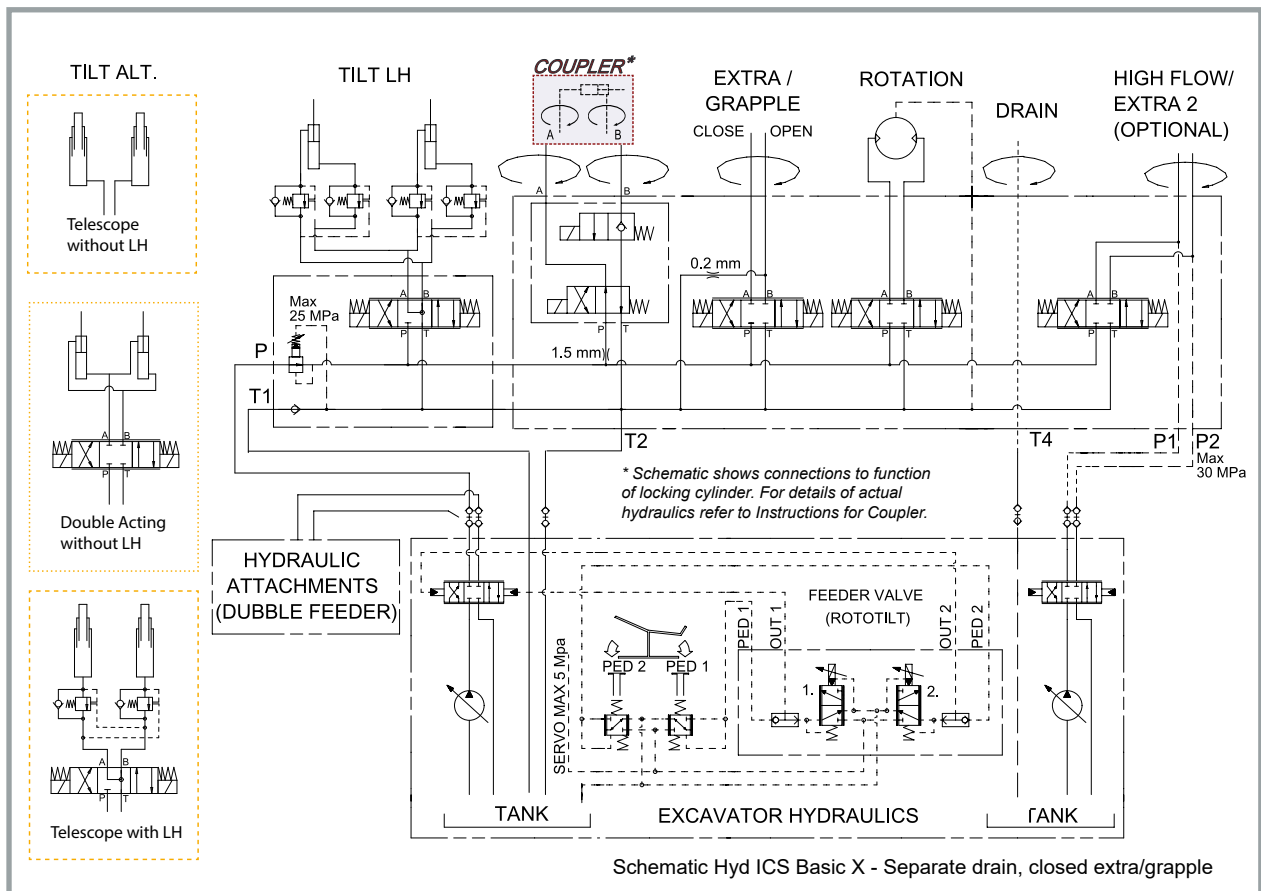
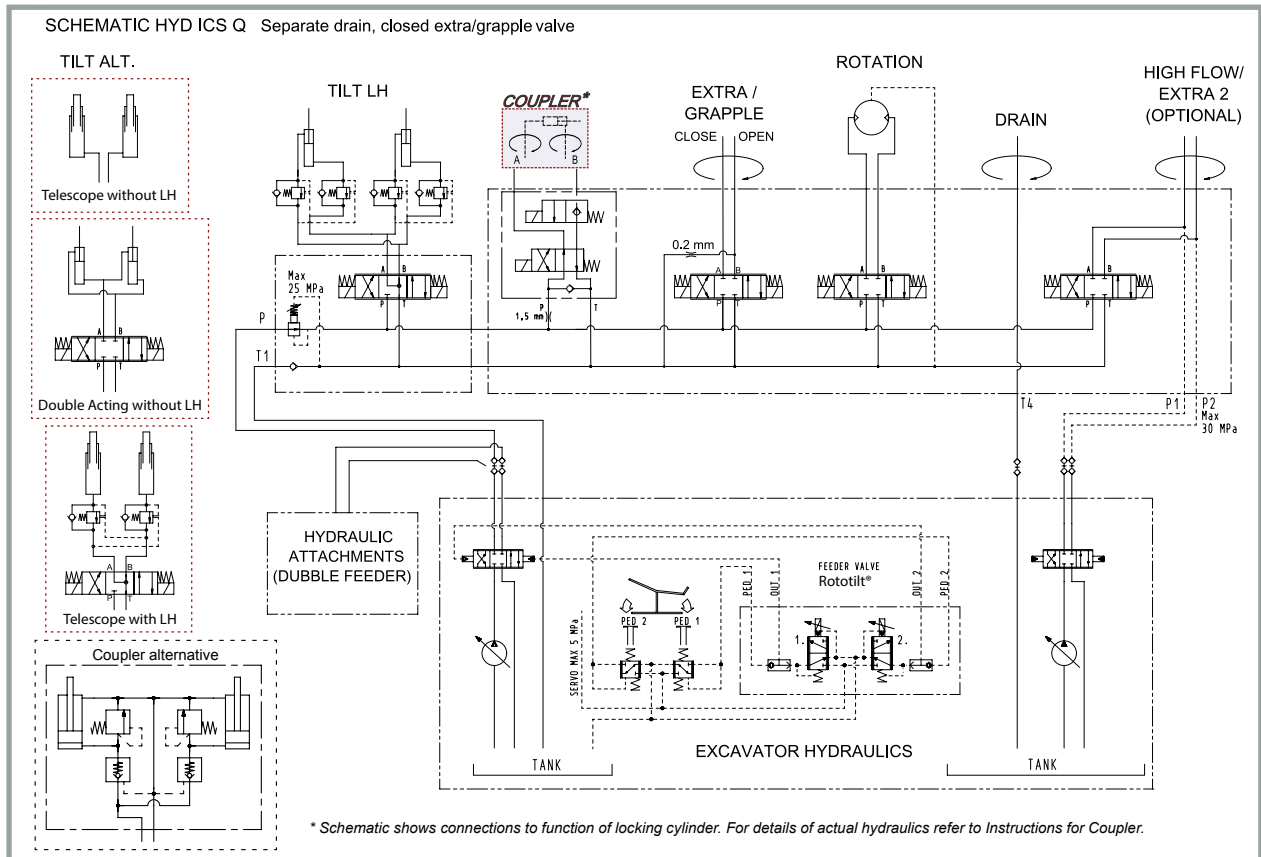

IMPORTANT - Connection T2 must be connected to a separate, non-pressurized return line, directly connected to the tank.

Harness Rototilt®

R1 Harness A

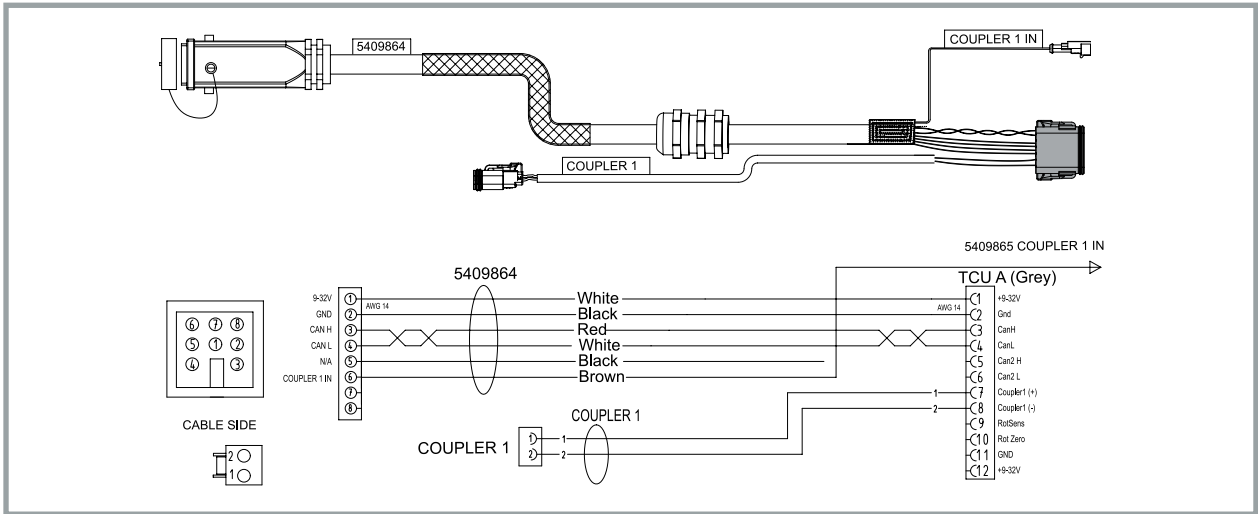

R2 - R8 Harness A

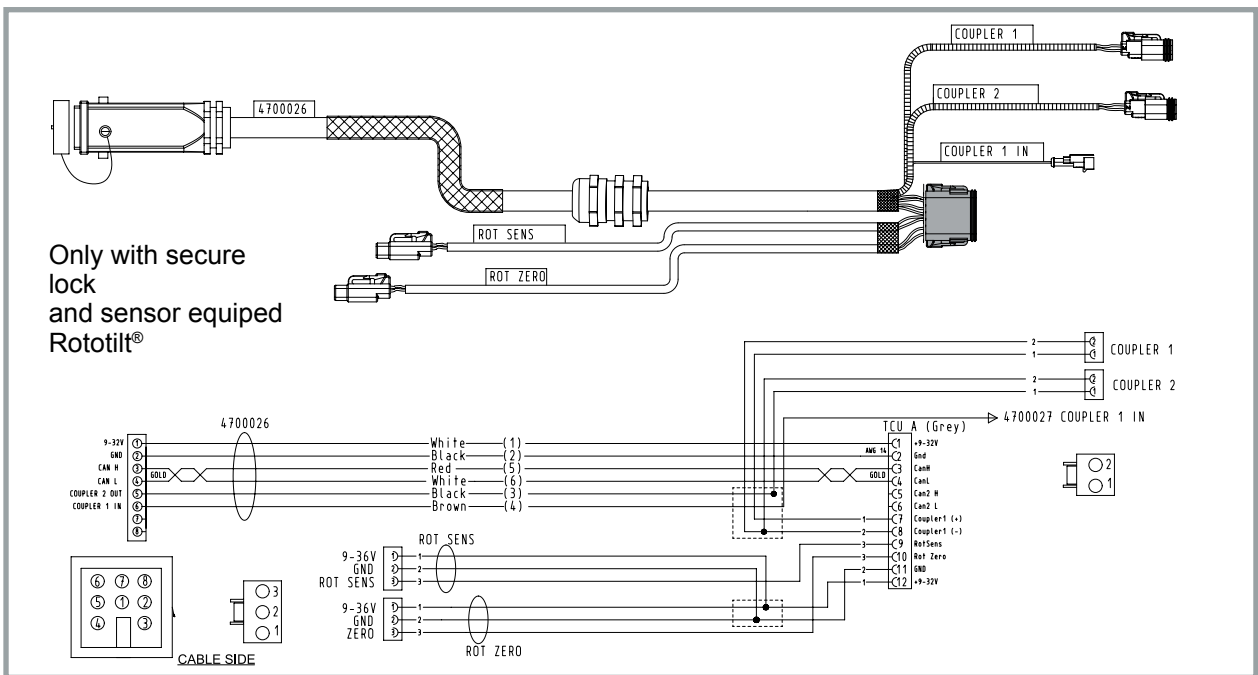

Harness A option oilquick

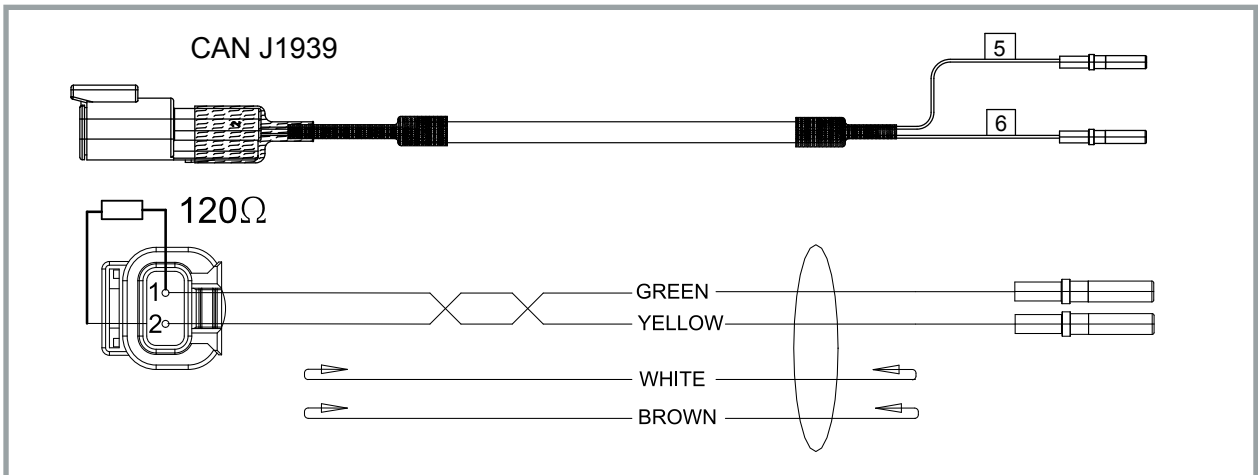

R1 Harness B

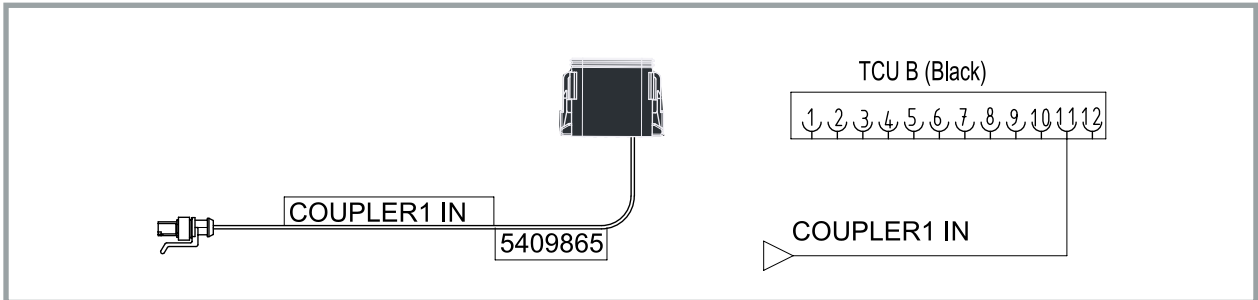

R2 - R8 Harness B

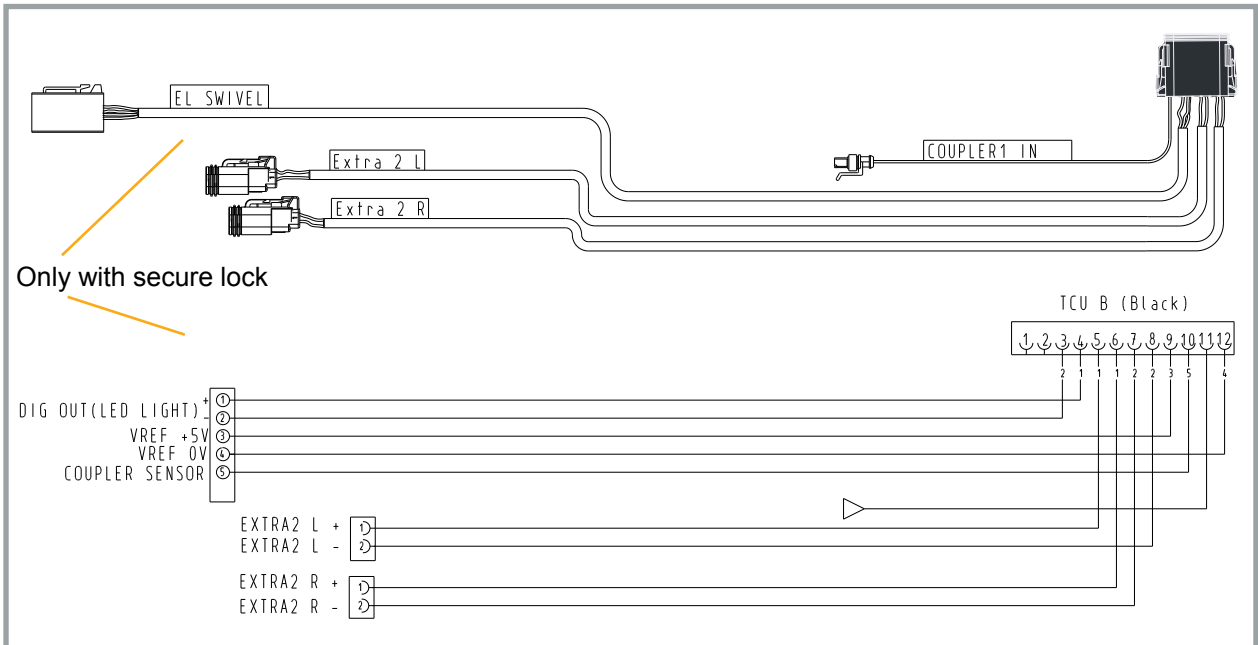

R1 Harness C

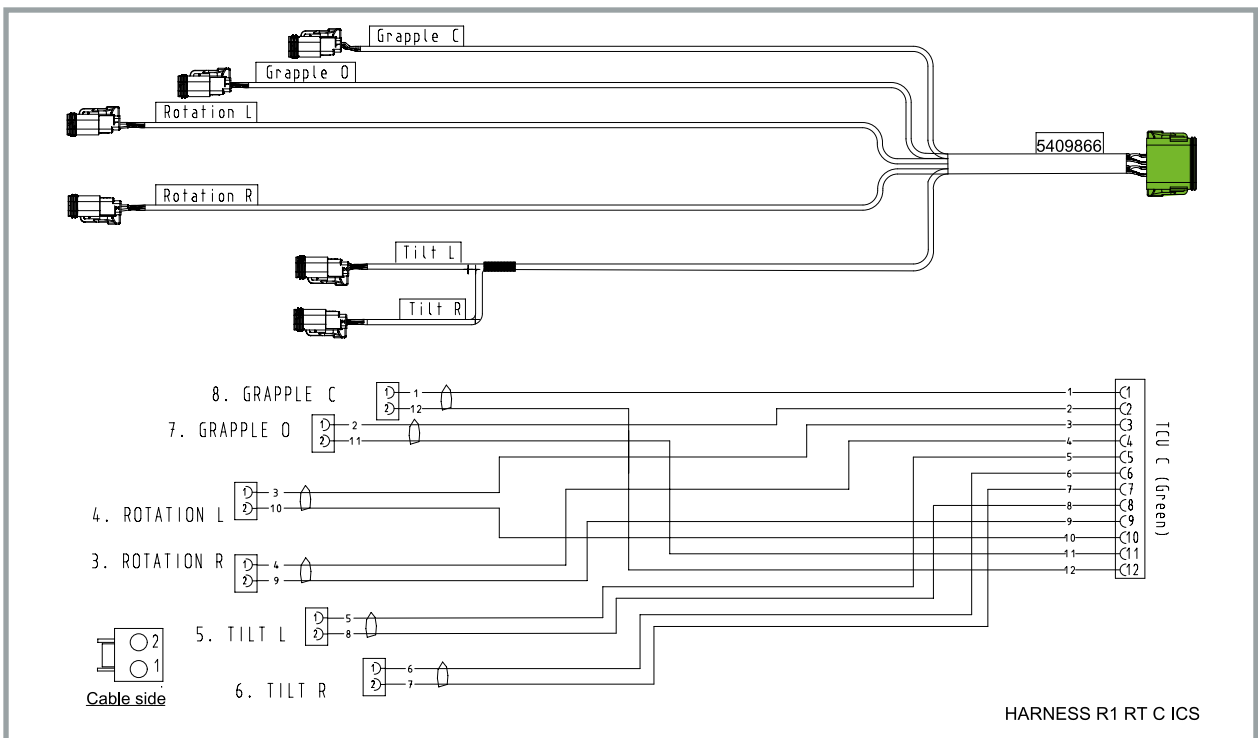

R2 Harness C

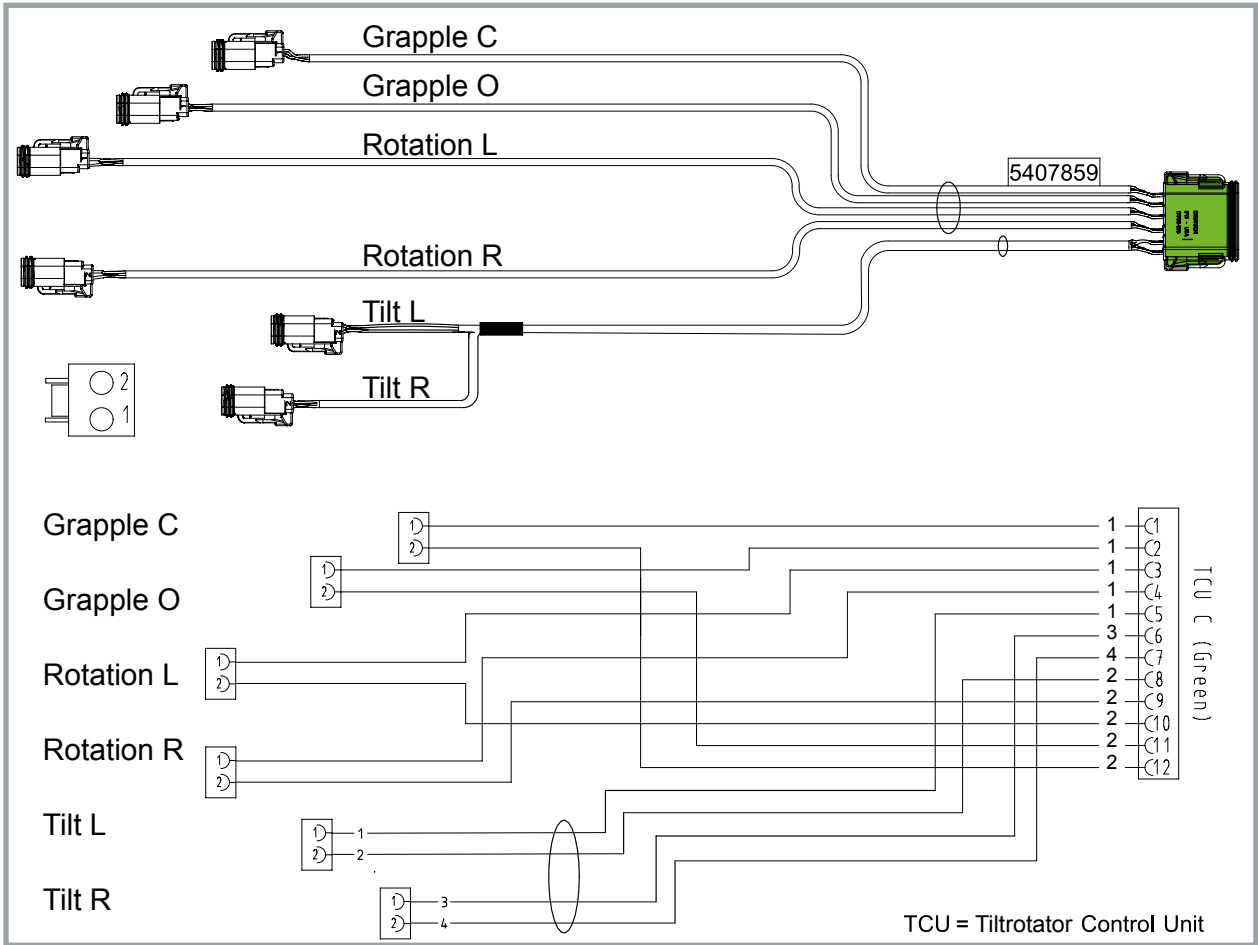

R3 - R8 Harness C

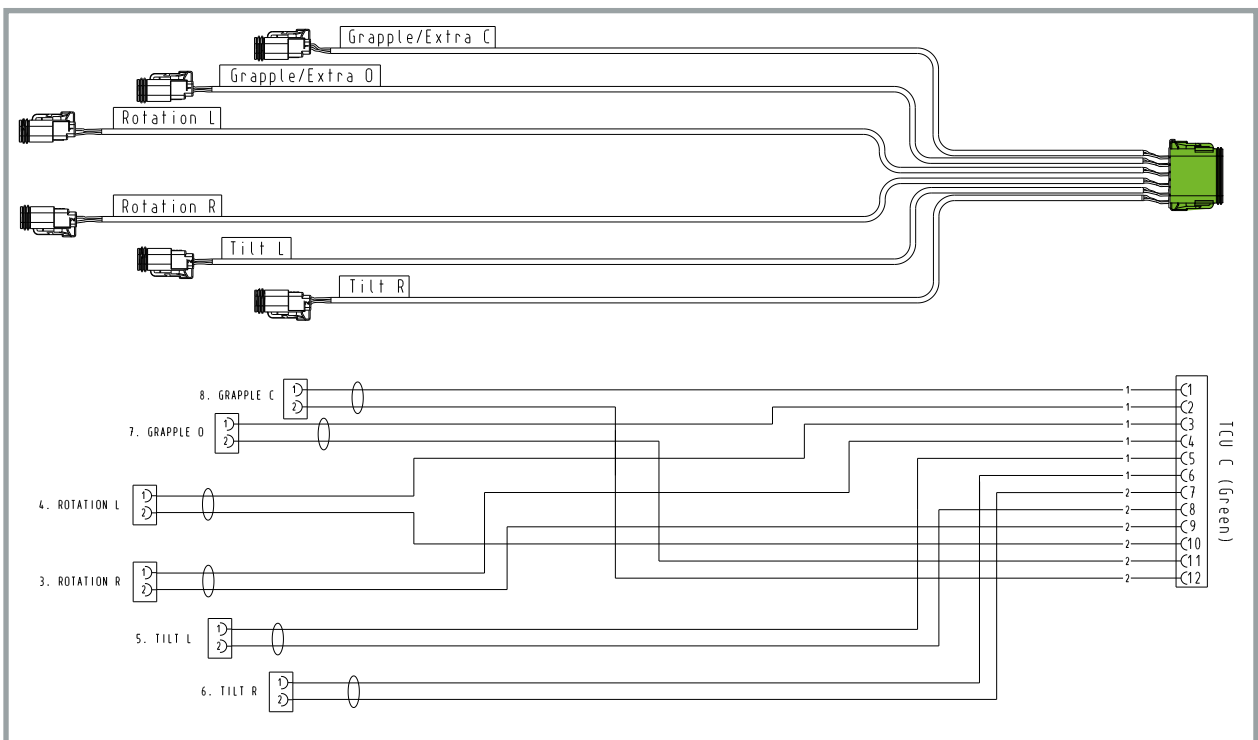

Secure Lock only: Each el.swivel have a number of wires available for optional connection. Cited inside heat shrink tubing. Max 2 Amp per wire. See arrows in illustrations below

Electric swivel oilquick RT -unit

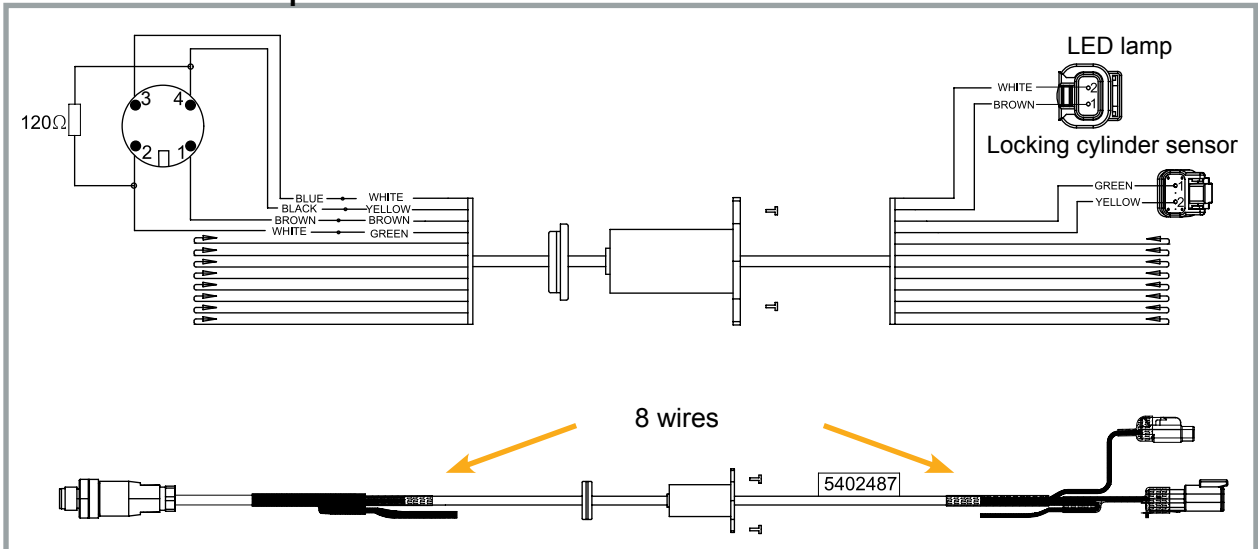

Electric swivel M12

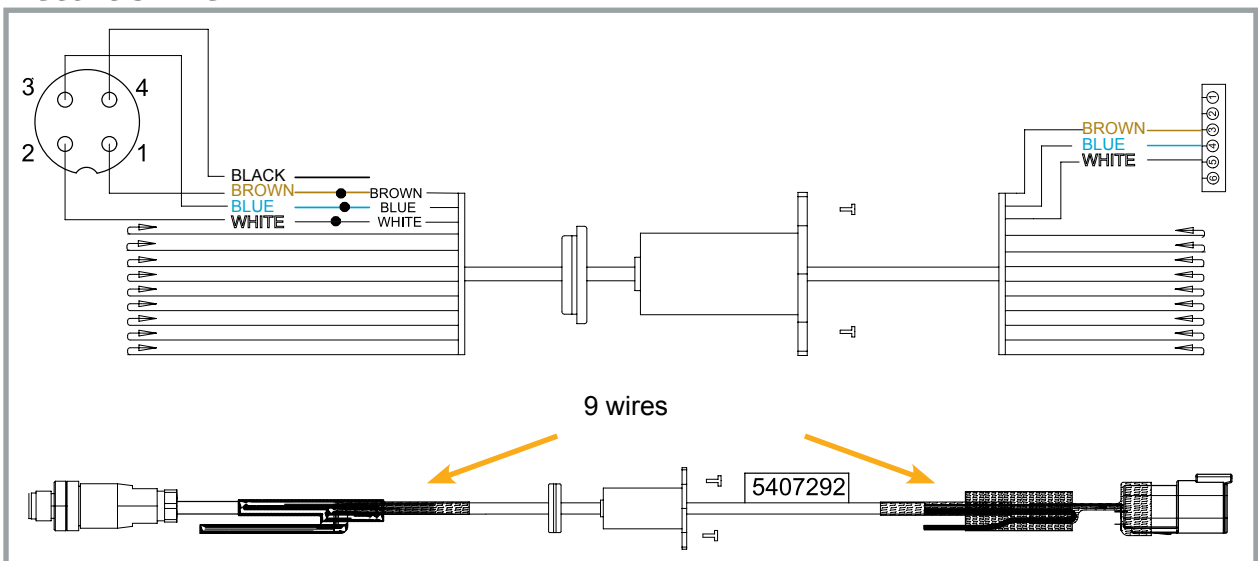

Electric swivel

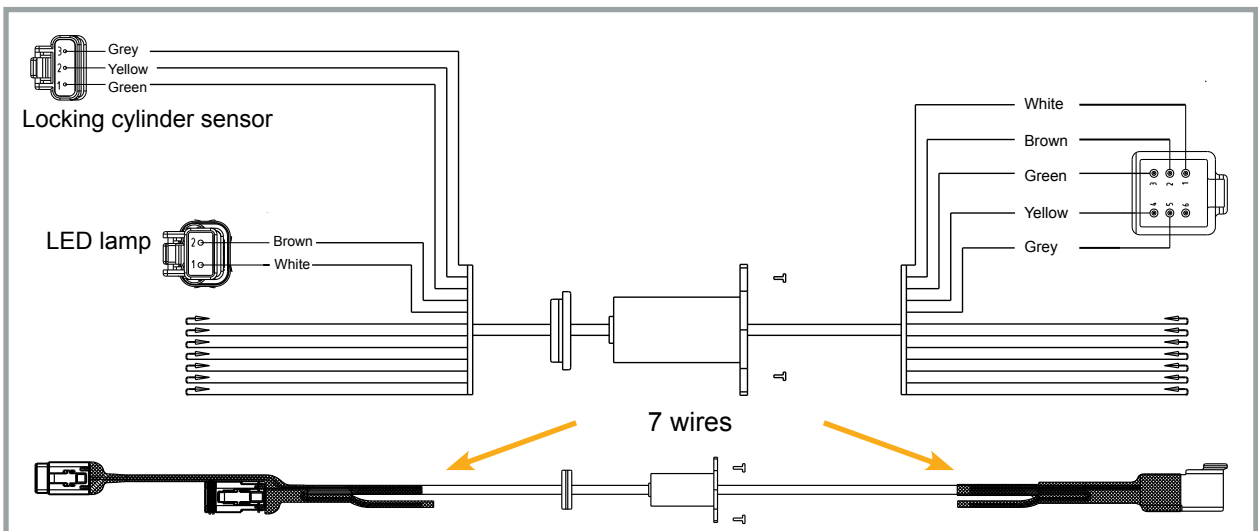

Machine Wiring ICS

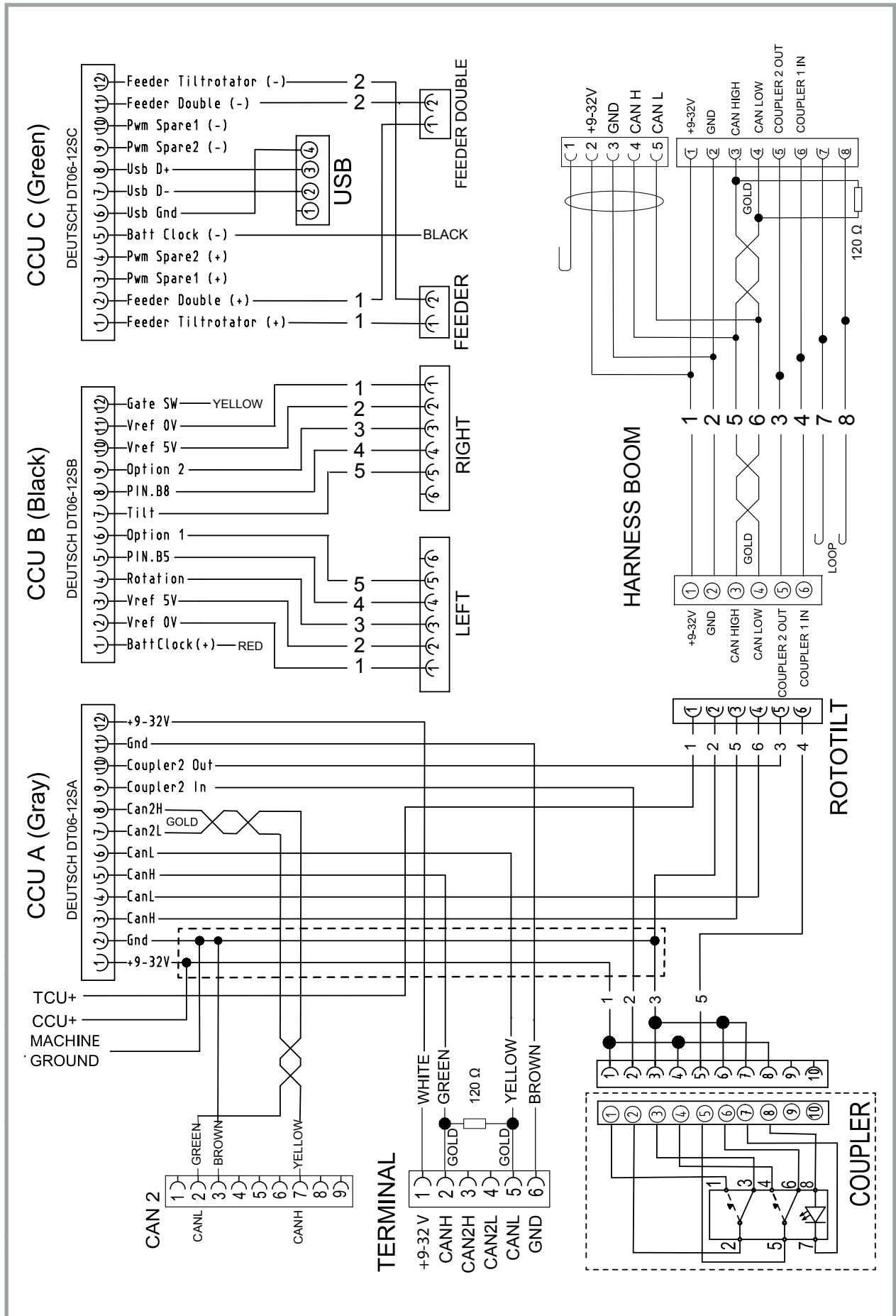

Cabin Harness A

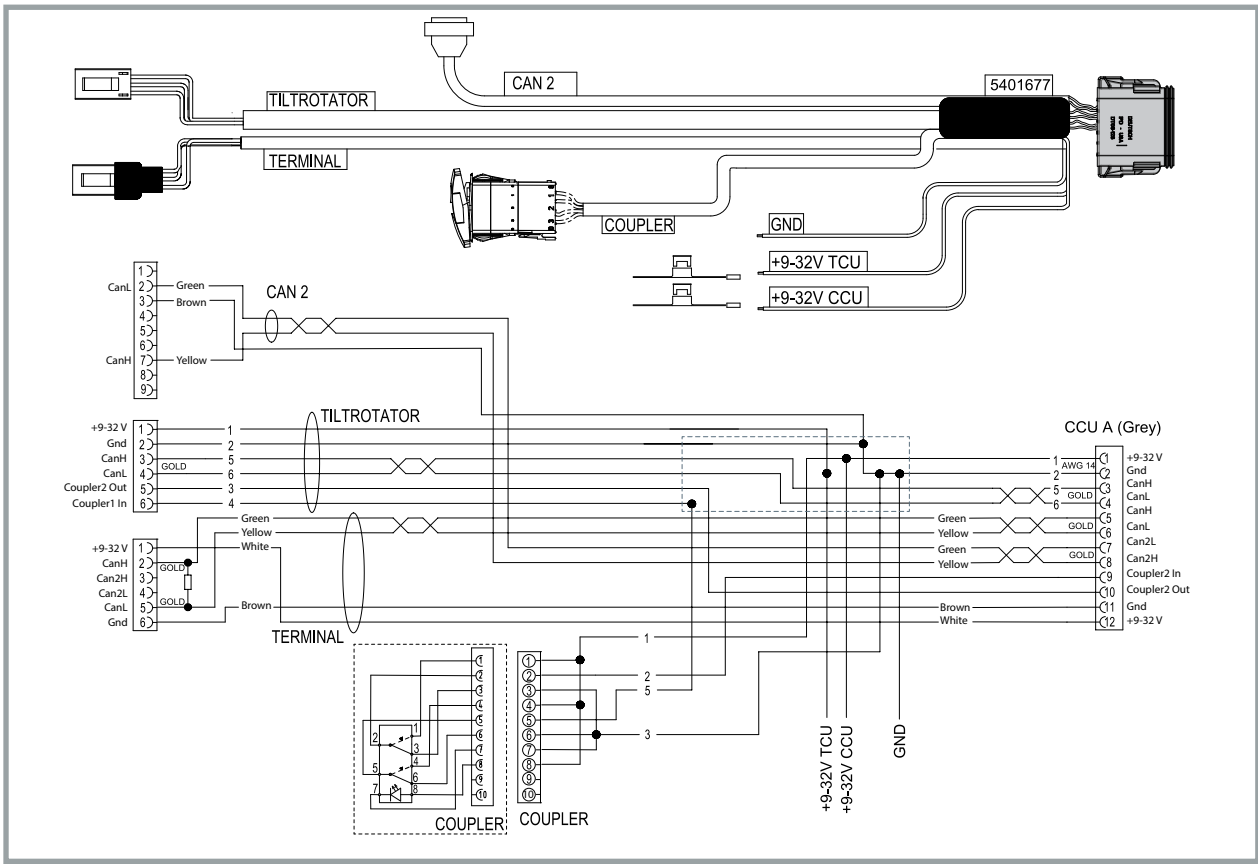

Cabin Harness B

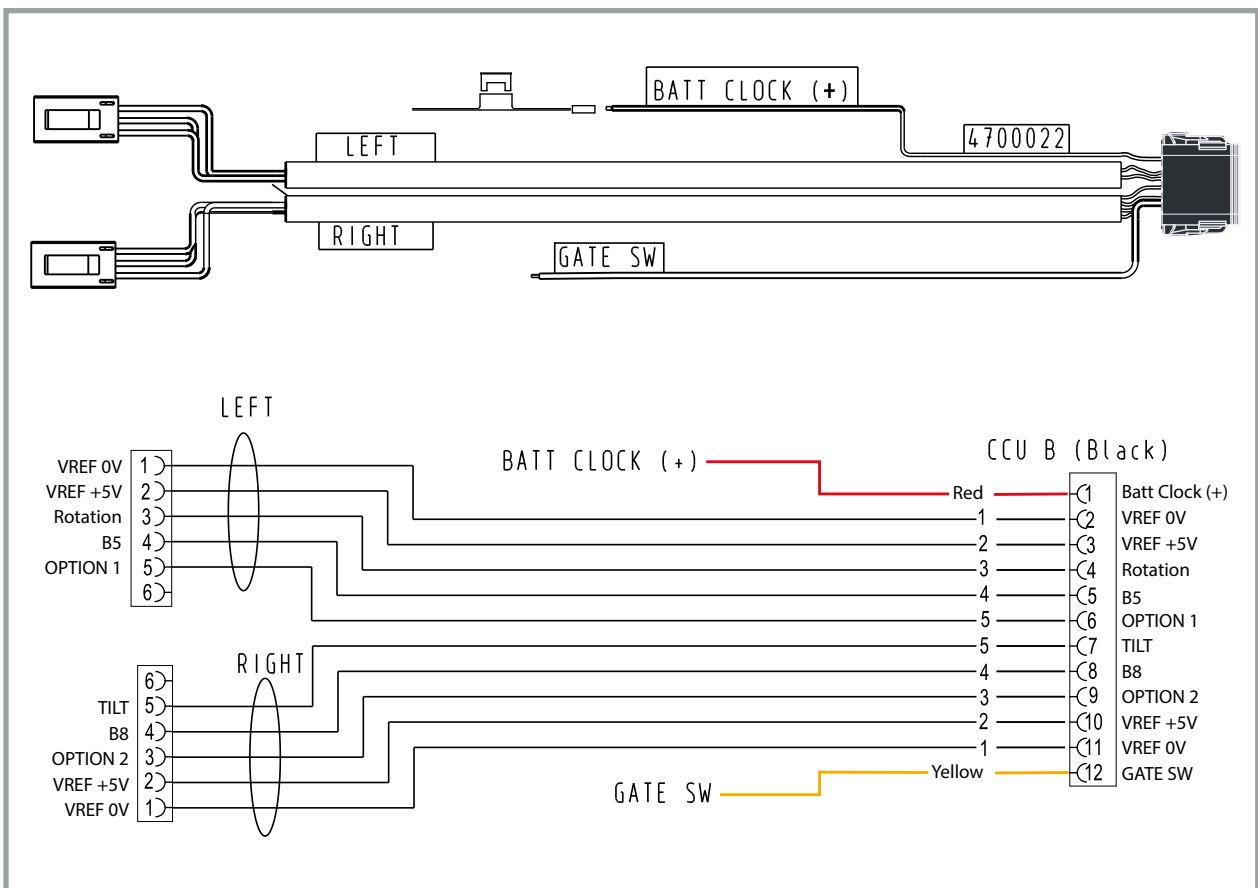

Cabin Harness C, original

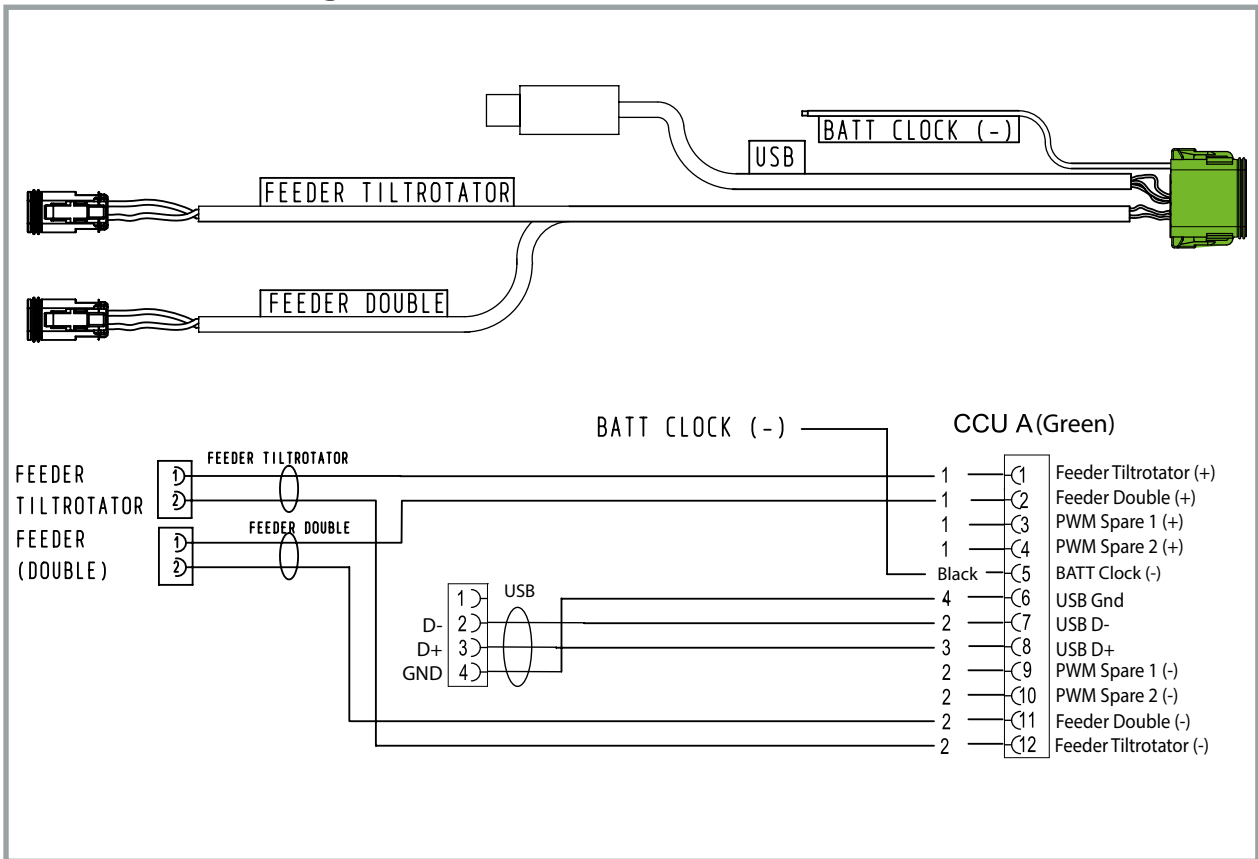

Cabin Harness C and option PWM Spare assembled

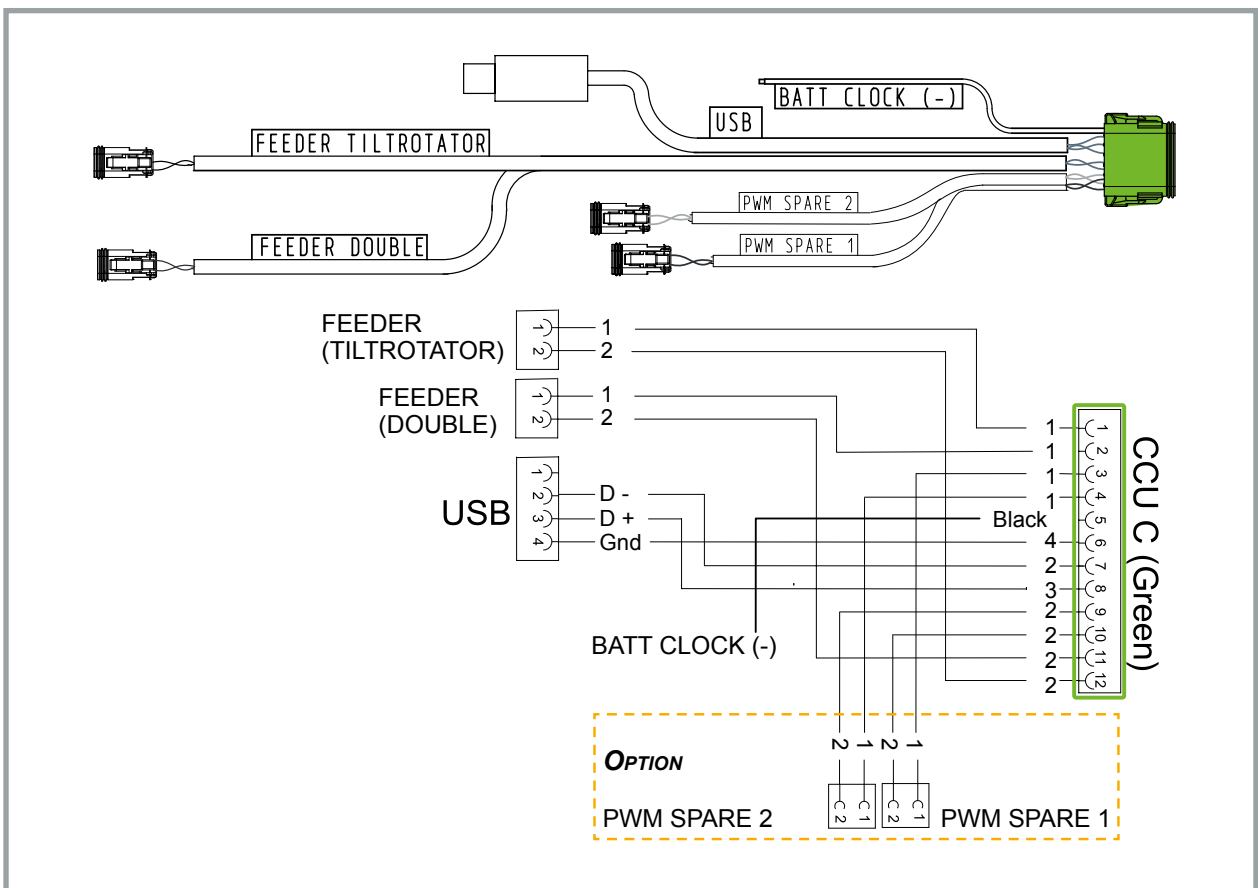

Harness Boom

5-pinned connector (M12)

Keep connector plugged and clamp to appropriate harness to keep from damage.
 When applicable; Remove plug and connect to corresponding connector for Machine Coupler with option Secure Lock.

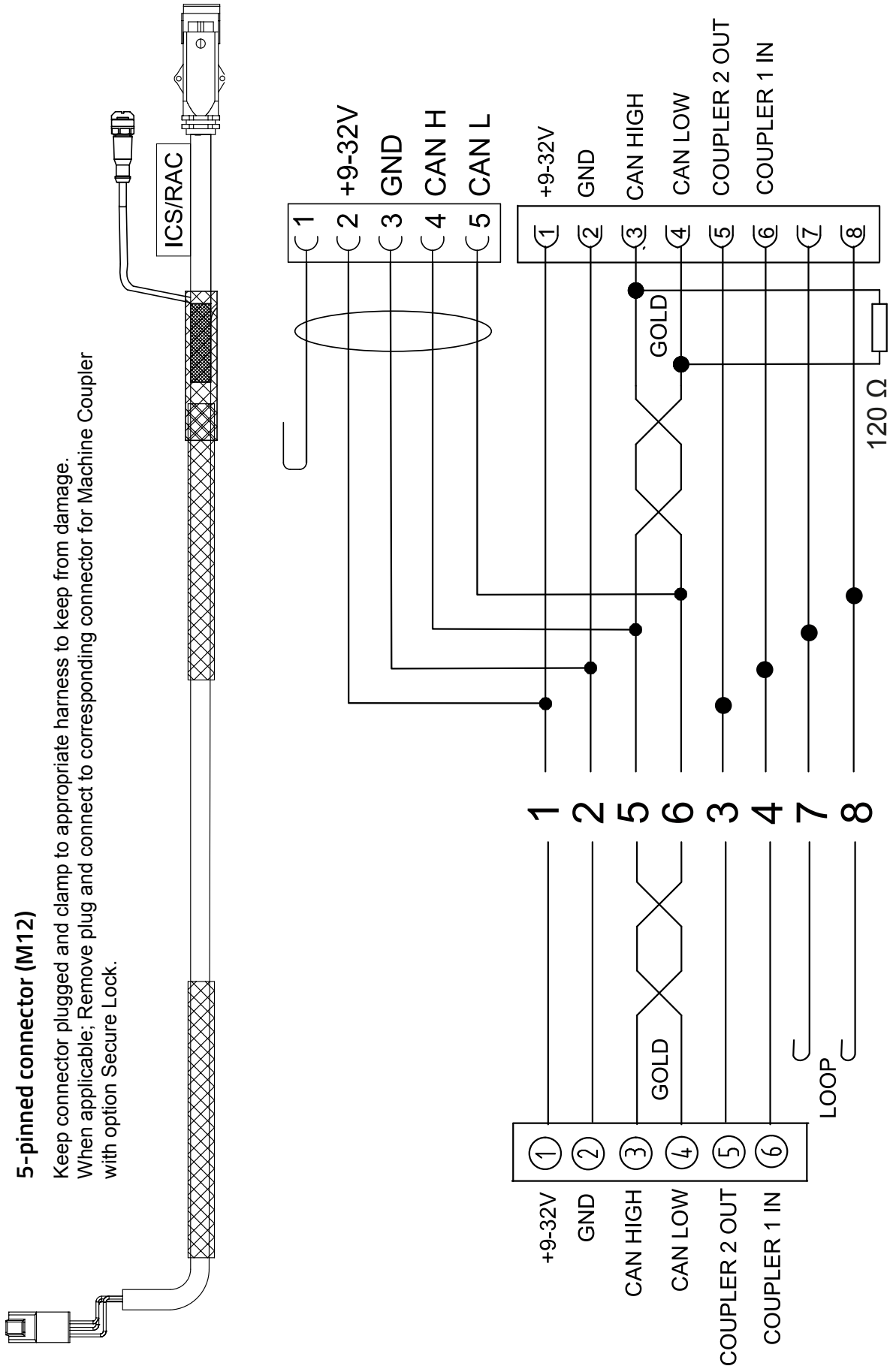

Overview - Alarm List

System error			
	Error message:	Possible causes	Remedial action
100	Software not started	SW. Missing, possible Can failure	Check CAN bus circuit.
101	No contact with Cabin unit	CAN bus failure	Check CAN bus circuit if orange led gives pulsating light. If no leds are on , check PWR harness.
102	Wrong software in display	Mismatch between software in display/ CCU or unable to verify that software in display/ CCU are matching.	Check Info for differences in software version Check CAN bus circuit.
110	Internal error	Software error, firmware mismatch. Will only show up in error log.	Contact the service workshop.
111	Output error	Error detected on output, most likely shortcut on digital output.	Check harness on indicated output
112	V-SYS error	Input voltage too low/high, check system voltage on machine.	Check harness for power supply if low, check alternator if high.
113	V-OUT error	N/A	
114	Temp error.	Internal temperature too low/high.	
115	VREF-OUT error	Error detected on 5V-output to rollers and sensor's.	Check 5V reference supply wires in harness to affected function
116	VCC error	Error detected on internal voltage.	Contact the service workshop.
117	VSS error		
118	VDD error		
119	HW error	Internal hardware error, most likely inclinometer.	Contact the service workshop.
121	Slave unit disconnected	Lost connection to slave unit, for example expansion unit.	Check CAN bus circuit.

Application error			
	Error message:	Possible causes	Remedial action
For more detailed information regarding the alarms below, consult the alarmlist in the display.			
1	Sensor circuit error, coupler!	Input signal fault from the coupler sensor.	Check the harness in terms of crush damage or open circuit. Check the sensor/ electrical swivel Contact the service workshop.
2	Service 8h, 40h, 160h, 500h	Service Refer to <i>Instructions of Use</i>	Perform service according to <i>Instruction of Use</i> and confirm.
3	Error coupler circ. 1 Error coupler circ. 2	Error in output signal coupler 2=CCU 1=TCU	Check the harness in terms of crush damage or open circuit. Contact the service workshop.
4	Wedge not in position!	Quick coupler not closed	Check the wedge, Refer to <i>Instructions of Use</i>
5	Wedge past position!	No tool attached	If correct: press OK, Refer to <i>Instructions of Use</i>
6	Coupler switch circuit defect!	Input signal to TCU and CCU not synchronized	Check the coupler switch harness in terms of crush damage or open circuit. Contact the service workshop.
7	Quick coupler open!		If quick coupler not opened check wedge
8	Roller outside range!	Voltage from roller outside range (0,5-4,5V). Cable breakage, connector play or roller fault.	Check the harness to the joystick in terms of crush damage or open circuit. Restart the system. Contact the service workshop.
9	Power output, feeder!	Error in output signal from CCU to feeder valve. Cable breakage or electric coil fault. Also valid for 0-5 Volt machine control applications.	Check the harness in terms of crush damage or open circuit. Check the condition of the valve. Return the roller to the zero position. Machine controll applications: Check PWM to analog module, connectors and harness Contact the service workshop.

Application error

	Error message:	Possible causes	Remedial action
For more detailed information regarding the alarms below, consult the alarmlist in the display.			
10	Pwr output, Tiltrotator!	Error in output signal (open or short circuit) at TCU. Go to error list, press OK on the alarm to see which function is defect. Cable breakage or electric coil fault.	Check the harness in terms of crush damage or open circuit. Check valve electric coils connectors and wires. Return the roller to the zero position. Contact the service workshop.
11	External voltage, coupler!	External voltage detected on output to coupler valve. 2=CCU 1=TCU	Check the harness in terms of crush damage or open circuit. Check valve electric coils connectors and wires. Return the roller to the zero position. Contact the service workshop.
12	Forced Double shunt!		Refer to Instruction of Use ICS
13	Uncalibrated Roller!	Roller not calibrated. The control system clears the roller's calibration and stops output signals. Connector play or roller fault.	Calibrate the roller by pulling it to each end position for at least 3 seconds. Change the roller and perform calibration as set out above Contact the service workshop.
14	Roller active at start!	Roller activated upon start-up of control system. The roller output signal and the output signal to the proportional valve are locked by the system.	Return the roller to its zero position. Check that none of the rollers are mechanically blocked. Check the condition of the rollers. Restart the system. Contact the service workshop.
15	Shut-off lever!	Shut-off-Lever in wrong position to operate.	Open and close the basemachine's Shut-off-Lever. Check harness, connectors and base-machine lever switch. Contact service workshop.
17	Coupler function disabled!	Coupler error	Check specific error, repair and restart
18	Double shunt active!	No tiltrotator attached, system in double shunt mode. Refer to <i>Instructions of Use</i>	
19	Steering error!	Problem with joystick steering, check display for specific error.	Go to Menu Troubleshoot, select alarm and confirm to get detailed information. <i>Refer to Instruction of Use : ICS Direct</i>
20	Steering Pressure!	Pressure too low in joystick steering	Adjust lower limit, <i>Refer to Installation Instructions ICS Direct</i>
21	Locking switch active!	Coupler switch engaged prior to display initiation	Deactivate Coupler Switch and try again.
22	Equipment not coupled!	QuickChange not correct attached	If tool is attached: <i>Refer to Instruction of Use : ICS</i>
23	Power output, AUX!	Error in output signal from expansion module.	Check the harness in terms of crush damage or open circuit. Check valve electric coils connectors and wires. Return the roller to the zero position. Contact the service workshop.
24	PWM-out! Cabin c.2	Error PWM passthrough 2, Error Feedback from PWM	Check the harness in terms of crush damage or open circuit. Check if PWM to analog module is OK
25	Power output, PWM-spare	Error in output signal from PWM spare	Check the harness to the joystick in terms of crush damage or open circuit. Restart the system. Contact the service workshop.
30	No pulses from rotation sensor!	Pulses from Rotation sensor required but missing.	Check if rotation function is OK Check the sensor Check the rotation indicator
31	Coupler sensor disabled	Error in coupler sensor acknowledged	Check the harness in terms of crush damage or open circuit. Check the sensor/ electrical swivel Contact the service workshop.