

**ARTICLE 2:
F1600/F2000
2026 TECHNICAL SPECIFICATIONS**



ARTICLE 2.1: F1600/F2000/Technical Specifications.....pgs 2-28

ARTICLE 2.2: Mazda MZR F2000/Technical Specifications...pgs 29-37
Clarification 6-8-24: Section 2.2.25.1 - Gear box and Differential

Revised 5-29-26



Article 2.1: F1600/F2000 Technical Specifications - 2026

These specifications are part of Formula Race Promotions (FRP) Competition Rules and all automobiles shall conform with these Specifications and FRP Pro Racing Rules (PRR).

F1600, F2000, is intended to provide competitors and interested manufacturers with the opportunity to compete in purpose built, highly modified open wheel single seat cars. FRP may alter or adjust specifications and require, permit, or restrict certain specific components to equate competitive potential as deemed necessary.

In an effort to control shock/damper technology and cost to a level reasonable for competitive racing, any fluid dampers are allowed, with the following restrictions:

1. Maximum of 4 dampers/shock absorbers per vehicle.
2. Dampers must be independent from each other with no interconnectivity. However, data acquisition is permissible, as long as it serves no other purpose.
3. Dampers must be manually adjustable only.
4. Mechatronic valves, G valves, hybrid inerters, inerters and mass dampers are prohibited.
5. Electro/Magnetic shock fluid is prohibited.

F1600 and F2000 PREPARATION RULES - 2026

Definitions

- a. F1600: A formula for single-seat, tubular frame, flat bottom, open-wheel racing cars using standard Ford 1600 "crossflow" pushrod engines, or a Honda Fit 1500 (L15A7) overhead cam engine, with firewall, floor, and safety equipment conforming to the FRP PRR.
- b. F2000: A formula for single-seat, tubular frame, flat bottom, open-wheel racing cars using the Ford 2 liter single overhead camshaft "NE" series engine, the 1971-74 Pinto/Capri 2 liter single overhead camshaft engine, or the Ford Zetec ZX-3 2 liter dual overhead camshaft engine.
- c. **F1600 and F2000 are restricted classes. Therefore, any allowable modifications, changes, or additions are as stated herein. There are no exceptions. IF IN DOUBT, DON'T.**

2.1.1. General Construction Restrictions

NOTE: Contained herein are the 1986 Formula F chassis construction requirements, revised January 1, 2013. All new F1600 and F2000 cars are to be built to these specifications. Any class-specific differences are stated explicitly. For cars registered prior to January 1, 1986, see section B.21. The use of carbon fiber and/or Kevlar reinforcement, titanium, beryllium, metal matrix composites, ceramics, high strength composites and similar materials is prohibited unless specifically permitted. The use of the word "unrestricted" in any section does not indicate the allowance of these prohibited materials. The use of non-metal materials for seals, bearing and bearing liners, thread locking systems, windscreens, mirrors, instruments, wiring, electronic systems, electrical systems, hydraulic and oil and cooling systems, etc, are permitted unless specifically restricted.

Fuel Capacity: Maximum capacity 41 liters (10.83 gallons)

Refer to the F1600/F2000 Dimensions Table for general dimensional limitations.

F1600 RAY with the Ford Sigma Engine – For the 2026 F1600 Championship season, a stock Ford Sigma 1.6 liter engine, sealed by FRP Tech staff or an FRP authorized engine supplier and using the required FRP restrictor plate and mandatory FRP ECU mapping shall be legal in competition and earn Championship points.

2.1.2. Chassis/Frame

- a. The chassis/frame and all bulkheads shall be of steel tube, bar and sheet space-frame construction only, and shall comply with Generally Accepted construction requirements. Monocoque-type structures are prohibited.
- b. The soles of the driver's feet shall not extend beyond the front edge of the wheel rims (in normal position (i.e., pedals not depressed) and shall remain behind the front bulkhead (per 9.4.5). The lower main frame rails shall be a minimum of 25 centimeters (9.84 inches) apart (inside dimension) from the front bulkhead to the rear roll hoop

- c. Forward-facing braces that protect the driver's legs and feet shall extend from the front roll hoop to the front bulkhead (The front bulkhead is defined as the transverse section of the frame immediately ahead of the pedals and drivers feet.) This does not preclude a secondary forward bulkhead ahead of this "front" bulkhead). The front bulkhead may be constructed from aluminum plate.
- d. Further reinforcement of the frame structure shall be in accordance with the allowances specifically stated herein. No other methods of reinforcement are permitted. No panels other than those which are explicitly described within the "Preparation Rules" set forth herein may be attached to the chassis/frame.
 - 1. The chassis shall carry a mandatory floorpan, and may incorporate optional bulkhead panels on the main and dash hoops, the front bulkhead immediately ahead of the drivers feet, and any secondary bulkhead located forward of the front bulkhead. The optional bulkhead panels may be attached in the same manner as the requirements set forth for the floorpan.
 - 2. A metal floorpan shall be rigidly attached to the lower surface of the bottom frame rails. At a minimum, it shall extend from the main roll hoop bulkhead to the front bulkhead. Floorpan material must be a minimum of .060 heat treated aluminum alloy and/or 18 gauge steel sheet only. Its curvature shall not exceed 25.4 mm (1.0 inch).
 - 3. The floorpan shall be, at the minimum, attached to the chassis lower rails at or adjacent to its full perimeter by any combination of welding, bonding, riveting, or bolting. The centers between any two adjacent fasteners shall be no more than 6 inches apart as measured along the panel surfaces. The floorpan may not "wrap up" on to the chassis sides to any point above the top surface of the lower main frame rails.
 - 4. The floorpan may be constructed in more than one section.
- e. The area between the upper and lower main frame tubes from the front instrument/dash roll hoop bulkhead to the rear roll hoop bulkhead shall be protected by at least one of the following methods to prevent the intrusion of objects into the cockpit. Panels may extend to the forward most bulkhead, but must otherwise comply with these regulations.
 - 1. Panel(s), minimum of either .060 inch heat treated aluminum (6061-T6 or equivalent) or 18 gauge steel, attached to the outside of the main frame tubes.
 - 2. Reinforced body, consisting of at least two layers of 5 ounce, bi-directional, laminated Kevlar material incorporated into the body which shall be securely fastened to the frame. (5 or more layers are highly recommended.) For either method, fasteners shall be no closer than 6 inch centers. The steel tubes used for the chassis braces in this area shall be at least equivalent to the roll hoop brace material.
 - 3. Flat composite panels of uniform thickness and construction attached to the outside of the main frame tubes. Shaping of these panels to conform with the outer perimeter of the main frame tubes is permitted. Carbon fiber is permitted; however, it must be used in conjunction with another "anti-ballistic" type material (e.g., Kevlar, Zylon, etc). Such material shall be at least 1.5mm (.060 inches) in thickness not counting the carbon fiber.
 - 4. Composite anti-intrusion panels shall be attached with no more than eight fasteners per side. Fasteners shall be AN or superior grade of not more than 0.25 inch diameter. Two flat or countersunk Mil Spec or SAE washers of no more than 1 inch diameter may be employed with each fastener. Ten fasteners per side are permitted if the panels extend to the front bulkhead.

Alternatively, FIA mounting is permitted as follows:

One panel shall be permitted per side. It shall be fastened to the frame at its extreme corners, the upper, lower, forward and rearward edge halfway between the corners, and halfway along each diagonal tube. The attachment should consist of an 8mm U-bolt and an aluminum plate 3mm thick, 20mm wide and 12mm longer than the U-bolt span.

Panel mounting must comply with one or the other above prescribed methods. It may not be a combination of the two.
 - 5. Alternate attachment method. Composite anti-intrusion panels may be attached to the outside frame with fasteners no closer than 6 inches (15 cm) centers. Fasteners shall be AN or superior grade of not more than 0.25 inch diameter. Two flat or countersunk Mil Spec or SAE washers of no more than 1 inch diameter may be employed with each fastener. No adhesives may be used for attachment purposes. Cars with composite panels, either interior or exterior, attached in this manner, are subject to a 25 pound weight penalty. Inlet restrictors may also be required. Composite panels attached to the interior and exterior of the frame rails must use common attachment points on opposite sides of the frame rail.
- f. No other exterior panels (excepting body work) shall be permitted in the area between the upper and lower main frame tubes from the forward most bulkhead to the rear roll hoop bulkhead. Suspension components shall not be mounted directly to any frame exterior panel (including, but not limited to body and anti-intrusion panels). The chassis must be capable of rolling without any such frame-exterior panels installed. The engine, bell housing/oil tank and gearbox are exempt from this limitation.

No panels or other components other than the required and optional load bearing panels may be attached to the chassis for structural purposes, except that the engine, bell housing/oil tank and gearbox are permitted to be stressed and/or load bearing.

- g. A firewall(s) that seals the drivers' compartment (cockpit) from the engine compartment is required. Forward facing ducts may be installed to delivering air directly to the engine compartment. Air duct openings may be located within the cockpit provided the firewall is extended to prevent the passage of flame and debris from reaching the driver.
- h. Brackets are permitted for the exclusive purpose of mounting components, such as the engine, transmission, suspension pickups, clutch and brake components. They shall be metal. Brackets shall not be used to otherwise reinforce the frame. Composite and/or non-metal bellhousings are prohibited.
- i. Brackets for the purpose of mounting or attaching bodywork may be of glass fiber or metal construction, and may incorporate honeycomb, wood, or foam coring for purposes of maintaining its shape under aero loading. Kevlar reinforcement is permitted.
- j. Instruments may be mounted in non-metal panels (e.g., composite, wood or plastic) securely affixed to the dash bulkhead.
- k. Impact Attenuators: Must meet FRP specification
- l. No engine oil or water tubes are allowed within the cockpit, except for shielded (stainless steel braid) mechanical oil pressure lines. Chassis tubes shall not be used as oil or water transport tubes.
- m. Fuel cell vents shall be located at least 25cm (9.84 inches) to the rear of the cockpit.

2.1.3. Bodywork

For the purposes of this section, bodywork includes all panels external to the chassis/frame and licked directly by the air stream. This includes panels above or below the floor pan, and the bottoms of any side pods.

- a. The bodywork opening giving access to the cockpit shall have the following minimum dimensions:
 - Length: 60cm (23.62 inches)
 - Width: 45cm (17.72 inches)This width extends over a length of 30cm (11.81 inches) minimum. This minimum rectangular opening may exist anywhere forward of the firewall. Forward-facing roll bar/cage bracing and padding will not be considered in these dimensions.
- b. The driver's seat shall be capable of being entered without the manipulation or removal of any part or panel, with the exception of the steering wheel and/or drivers head surround. The steering wheel and the surround must be removable by the driver and/or safety workers without the use of any tools. Readily legible removal instructions for safety workers are recommended. Bead seats are recommended.
- c. Bodywork and rear spoiler(s) and any attached components except for suspension components shall not exceed a maximum width of 95cm (37.40 inches). No part of the bodywork, rear spoiler or exhaust system shall extend more than 100cm (39.37 inches) F1600; 80cm (31.50 inches) F2000 behind the centerline of the rear axle. Allowances shall be made for radius of bodywork along primarily horizontal surfaces in this area. Undertrays and floorpans may extend laterally past cockpit sides, sidepods, and engine compartment enclosures, but only up to the 95cm (37.40 inches) maximum allowed width.
- d. Diffusers and undertrays shall not exceed a maximum width of 95 cm (37.40 inches). No part of the diffuser or undertray shall extend more than 80 cm (31.50 inches) behind the centerline of the rear axle nor exceed in height a horizontal plane 90cm (35.43 inches) above the ground with the car as qualified or raced with the driver on board.
- e. Bodywork shall be of aluminum or glass fiber construction and may incorporate honeycomb, wood, or foam coring for purposes of maintaining its shape under aero loading. Kevlar reinforcement is permitted. All bodywork shall be attached to the chassis such that it is not capable of coming loose when the car is in operation.
- f. Cockpit is defined as the volume which is inside the inner surface of any panel attached to the outside of the frame rails between the rear roll hoop and the front bulkhead.
- g. Cockpit interior panels may be constructed of glass fiber, carbon fiber, metal and/or Kevlar. Such panels shall be contained completely within the frame and may not be attached to the frame with fasteners closer than 6 in (15 cm) centers measured along the surface of the panel. The chassis must be capable of rolling without any such interior panels installed.
- h. Mirrors, air ducts/intakes which do not serve any structural purpose other than directing air flow into the engine or other permitted areas and the required Zetec air scoop may be constructed of carbon fiber and/or other composites.

2.1.4. Control of Undersides Shaping

It is the intent of these rules to minimize (not eliminate) the use of “ground effects.”

a. A reference area is defined

F1600: by the full width of the lowest surfaces of the car licked by the air stream between the front bulkhead as described in 3.a above and the rear of the rear tires.

F2000: by the full width of the lowest surfaces of the car licked by the air stream between the rear edge of the front tires and the front edge of the rear tires.

These surfaces may include the floor pan, undertrays, diffusers, side pod bottoms and any essentially horizontal bodywork that is included in the lowest surfaces licked by the air stream. Within this reference area, the lowest surfaces licked by the air stream must be flat with a total vertical tolerance of 25.4mm. An undertray beneath the engine, bell housing and/ or gearbox is not required.

1. Mirrors and any primarily vertical bodywork (e.g., cockpit/radiator sides that are oriented 45 degrees or greater relative to the ground) that extend laterally past the outer edges of the floor pan and/or undertrays are not subject to the reference area restrictions.
2. Fairings for streamlining suspension pickups are not subject to the reference area restrictions; however, such fairings shall be symmetrical about their horizontal axis.
3. The perimeter of any reference area surface that transitions upward to any bodywork may use a maximum 1 inch radius and shall be included in the reference surface measurement.

b. Measurement for compliance of the defined area shall be performed as follows:

1. A non-flexible straight-edge bar shall be placed against the lower surface of the reference area in a suitable section (unworn and flat enough to prevent rocking of the bar) from which the bar can be oriented to measure all parts of the reference area. The competitor shall be responsible for the availability and condition of such a surface. The bar shall be of sufficient length to reach all portions of the reference area from that surface.
2. All measurements shall be taken vertically from the bar to the reference area surfaces. The total maximum vertical distance (additive upward and downward) from the bar to any part of the reference area surfaces shall be 2.54 cm. Skid blocks, fasteners, and or rub strips are not included in this measurement.

c. No aerodynamic devices (e.g., skirts, body sides, skid “planks”, undertrays, skid blocks, etc.) may extend more than 1 cm (.394 inches) below the reference area.

2.1.5. Aerodynamic Aids

- a. A wing shall be defined as any shape that has a leading edge and a trailing edge and creates downforce.
- b. Wings and other airfoil devices (“dive planes”, etc.), whose primary purpose is to create aerodynamic downforce, are prohibited in F1600.
- c. Both front and rear wings/airfoils are a requirement for F2000. See the F1600/F2000 Dimensions Table. Cockpit or remote adjustment is not permitted; wings and airfoils shall be non-movable when the car is in operation.
- d. Any part of the car which has an influence on the aerodynamic stability of the vehicle shall be firmly attached with no provisions for adjustment to vary downforce while the car is in motion.
- e. Shaping of the lower surfaces to create “venturi” type tunnels is prohibited. An example of venturi tunnels is shown in the following figure.



- f. It is not permitted to duct air through any part of the bodywork for the purpose of aerodynamic downforce. There shall be no forward facing gaps or openings in or about the bodywork with the exception of those necessary for engine cooling, engine air inlet, shock, or brake cooling. All ducted air for heat exchangers shall pass through those heat exchangers
- g. Primarily vertical air diverters greater than 30 inches forward of the main hoop (i.e. - "bargeboards") that stand away from the cockpit sides and are attached to (or through) the cockpit sides, undertrays and/or sidepods shall be considered as creating forward facing gaps and shall be prohibited.
- h. (F1600 only) A single rear spoiler, that may be capable of adjustment, is permitted. Cockpit adjustment is not permitted. This spoiler shall be no wider than the surface to which it is attached, and there shall be no gap between the spoiler and the body surface to which it is attached.
- i. (F1600 only) No part of the bodywork is allowed to have any down-turned fences or intermediate strakes. Undertrays are allowed, but any portion within the reference area (4.a) must comply with the reference area measurement rules. No bodywork below the horizontal centerline of the differential and to the rear of the rear tires may be wider than 16 inches.
- j. (F2000 only) Diffuser undertrays, to the maximum allowed bodywork width are permitted, but any portion within the reference area (4.a) must comply with the reference area measurement rules.
- k. Wings, endplates and their attachment(s) shall be of metal or glass fiber construction, and may incorporate honeycomb, wood, or foam coring for purposes of maintaining its shape under aero loading. Kevlar reinforcement is permitted.

2.1.6. Suspension

Suspension is defined as the system of springs, shock absorbers, control arms, links, etc., supporting the vehicle on its axles. Sway bars, sway bar links, steering components, etc., are not considered as suspension in this section.

- a. All suspension components shall be of steel or ferrous material, with the exception of hubs, hub adapters, hub carriers, bell cranks, pivot blocks, bearings, bushings, spring caps, abutment nuts, shock absorber caps and nuts, which may be of aluminum alloy. Material restrictions as set forth in Section B.2 above shall control.
- b. Front and rear hub carriers shall be only steel, aluminum or magnesium alloy for cars manufactured after January 1, 1983.
- c. Springs shall be steel only.
- d. Control arms and all associated items that attach directly to the chassis members shall be boxed in or captured to prevent intrusion into the cockpit. "Anti-Intrusion" bars are highly recommended on the front suspension arms.
- e. Sway bars, sway bar links and steering components are unrestricted, except as specified in Prologue or Section 2.1.1.
- f. It is not permitted to attach spoilers, fairings or other devices that may exert downforce to the movable suspension members. If the suspension member is of streamline or airfoil cross section, it shall be symmetrical about its horizontal axis. Brake lines may be attached to suspension members. Brake lines may be enclosed in a symmetrical fairing.

2.1.7. Brakes

Unrestricted, except:

- a. Maximum of 4 pistons allowed per caliper. Calipers must be ferrous or aluminum alloy
- b. Brake rotors are restricted to ferrous material
- c. Inner wheel fairings and/or ducts are NOT permitted

2.1.8. Steering

Unrestricted.

2.1.9. Wheels and Tires

Wheels are unrestricted except that:

- a. Material must be metal.
- b. Diameter shall be thirteen (13) inches.
- c. Rim width:
 - F1600: shall not exceed 5.5 inches.
 - F2000: shall not exceed 6.0 inches front and 8.0 inches rear.
- d. All measurements shall be taken between the beads.
- e. The only allowable tires that can be used in Qualifying or a Race are outlined in Section 2.1.20.

2.1.10. Engines

F1600 engines

The only permitted engines are:

- a. The Ford 1600 GT "Kent" pushrod "crossflow" as installed in the Ford Cortina in 1971 and later. The Kent engine specifications are contained in Section 2.1.11.
- b. The Ford 1600 GT "Cortina" engine as installed in the Ford Cortina through 1970. The Cortina engine specifications are contained in Section 2.1.12.
- c. The Honda Fit (L15A7) 1500cc overhead cam engine as installed in a Honda Fit (all models starting 2009). The Honda Fit engine specifications are contained in Section 2.1.13.

F2000 Engines

The only permitted engines are:

- a. The Ford 2 liter single overhead camshaft "NE" series engine or the 1971-74 Pinto/Capri 2 liter single overhead camshaft engine. The specifications are contained in Section 2.1.14.
- b. The Ford Zetec ZX3 2 liter dual overhead camshaft engine. The specifications are contained in Section 2.1.15.
- c. The Mazda MZR 2L - See Article 2.2

2.1.11. Kent Engine

a. General

1. Components shall not be interchanged between the Kent and Cortina versions of the engine unless specifically authorized.
2. The engine shall not be altered, modified, or changed in any respect unless specifically authorized herein. When a system is specified to be "unrestricted" (e.g. paragraphs p and q), the restrictions of this paragraph do not apply.
3. The gasket face of the cylinder head may be resurfaced provided the maximum compression ratio is not exceeded.
4. Valve guides are unrestricted provided the position of the valve is not changed. Standard Ford replacement valves, with oversize stems, may be used as normal repair/maintenance procedures. The specifications, in B.12.f are mandatory. It is permitted to re-cut or replace valve seats. Valve seat angles are unrestricted.
5. Exhaust emission control, air pumps, and associated lines and nozzles shall be completely removed. When these air nozzles are removed from a cylinder head, the holes shall be completely plugged.
6. Balancing of all moving parts of the engine is permitted. The pistons, rods, crankshaft, and flywheel may be lightened to their stated minimum weights. It is permitted to polish parts of the engine providing the contour of the part is not altered and can be recognized as the original part. Pistons may be balanced to the minimum weight by removing weight from the pin boss, the underside of the piston crown, or the bottom edge of the skirt. "Gas porting", re-profiling, or any other modification to the piston, other than expressly permitted herein, is prohibited. Knife-edging the crankshaft throws is not permitted
7. Compression Ratio
Maximum compression ratio: 9.3 to 1
The following specifications are used in determining compression ratio:
 - A. Maximum bore size: 3.200"
 - B. Minimum cylinder volume at Top Dead Center: 42.0cc
 - C. Maximum valve protrusion from head surface: .040"
 - D. Only approved head gaskets may be used (see 11.c.3)

b. Block

1. Bore may be enlarged for clearance between cylinder and piston.
2. Cylinder sleeves may be fitted. The top surface of the block may be milled or surface ground to obtain the maximum compression ratio specified above. Any steel center main bearing cap may be used. The oil pump mounting face on the block may be machined for the purpose of fitting an oil pump.
3. The 1600 Fiesta block is permitted as a replacement part.
4. The Ford Racing block, part number M-6010-16K, is permitted as a replacement part.
5. The block may be relieved in those areas only as required to allow the fitment of a permitted crankshaft.

c. Cylinder Head

1. Ports may be reshaped by the removal of metal as long as the port diameter at the manifold face of the head does not exceed the following dimensions:
Inlet: 1.50" Exhaust: 1.20"
2. The use of the Pierce aluminum cylinder head is permitted.
3. The following head gaskets are allowed:
 - A. Ford Part # 931M6051AA
 - B. Payen Part # AH-750
 - C. Felpro Part # 8360PT-1

d. Inlet Manifold

1. The ports may be reshaped by the removal of metal as long as the following dimensions are maintained:
Maximum dimension at head face: 1.340"
2. Carburetor Flange- Maximum dimensions at carburetor flange: see Figure 1.
3. The carburetor face of the inlet manifold may be machined to the horizontal to compensate for fore/aft tilt of the carburetor.
4. Epoxy exposed in the manifold used to make repairs is acceptable, providing the total area is less than 0.75 square inches.
5. The water passages in the inlet manifold may be plugged. Holes in the inlet manifold resulting from the removal of emission/vacuum lines shall be plugged.

e. Pistons

1. Standard or 0.005 inch oversize pistons shall be used.
2. Standard size AE pistons P/N 18649, casting P/N 18634, standard size CP piston, part # 81-2 FF1600, or CP oversize piston, part # 81-2- FF1600+5 may be used. CP oversize piston, part #81-2-FF1600+5 may be used. CP pistons bearing part #81-2-ff1600 or #81-2-FF1600+5 must bear the Ivey logo.
3. Alternate piston identified as follows is allowed: P/N AE-M717D, casting number 711 M 6110. AE Hepolite P/N 20552, Casting # 20548A. Note: Mahle pistons are not allowed.
4. Dimensions and Weights
Maximum diameter:

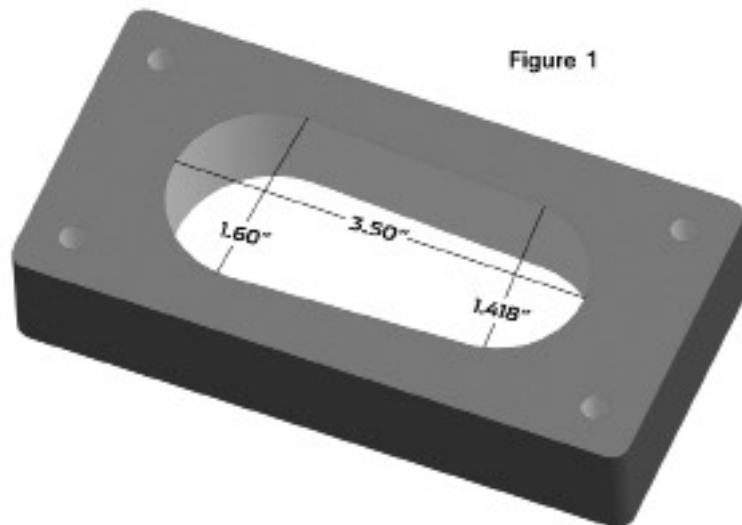

Standard:	3.187"
0.005" o/s:	3.192"
Depth of bowl:	0.470" (minimum)
Maximum diameter of bowl:	2.44" AE Hepolite, 2.50" CP Piston
Centerline of wrist pin to crown:	1.702" +/- .002"
Overall height:	3.30" AE Hepolite 2.80" CP Piston
Minimum weight	515 grams (w/ clips, pins and rings)
Weight of pin:	115 +/- 2 grams
Ring Groove Widths:	Top Groove: 0.064" 2nd Groove : 0.0795" Oil Groove: 0.159"

5. Piston rings are unrestricted provided that:
 - A. One oil control and two compression rings are used.
 - B. No modification is made to the piston for the installation of rings.
 - C. Pocketing of the piston valve reliefs is allowed up to a maximum of .050" to obtain the maximum combustion chamber volume.
6. Wrist Pins are unrestricted provided that:
 - A. Weight is 115 +/- 2 grams.
 - B. No modification is made to the piston for the installation of the wrist pins.

f. Valves

1. Dimensions

	Iron head	Alloy head
Distance apart at centers	1.540" +/- .020"	1.570" +/- .020"
Max. diameter:	Inlet: 1.560" Exhaust: 1.340"	
Overall length:	Inlet: 4.367" +/- .020" Exhaust: 4.355" +/- .020"	

2. Reshaping of the valves is specifically prohibited.
3. Alternate valve AE p/n V34524 (intake), V34525 (exhaust) are permitted.

g. Camshaft

1. Regrinding camshaft lobes is permitted, providing they are ground to meet FORD and SCCA profile.
2. Camshaft Lobe Centers: 109° +/- 2°

Lift at top of pushrod:

Inlet:	0.231" +/- .002" Maximum
Exhaust:	0.232" +/- .002" Maximum

Lift at spring cap: (Valve Lift)

Inlet:	0.356" Maximum
--------	----------------

(Zero tappet setting)

Exhaust:	0.358" Maximum
----------	----------------

3. Recontouring of the valve stem contact pad of the rocker arm is permitted, provided the maximum lift at the spring cap is not exceeded
4. Offset camshaft/sprocket dowels are permitted.
5. Camshaft profile and lobe centers shall be checked using the official procedure published by SCCA.
6. A camshaft that is a replica of the original camshaft and of the same material may be used.

h. Valve Springs

Valve springs and valve spring shims are unrestricted, except that:

1. Springs and shims shall be made of steel.
2. No more than one spring shall be used per valve.
3. Conically wound springs are not allowed.
4. The standard spring cap and retainers shall be used.

i. Pushrods

Minimum stem diameter: 0.25"
Overall length: 7.64" Minimum
Minimum weight: 50 grams

j. Connecting Rods

Any ferrous connecting rod may be used provided it meets a minimum weight of 630 grams and has a center to center length of 4.925 +/- 0.020 inches. (Note: Weights include cap, bolts, and small end bush, but not big end bearing shells).

k. Crankshaft

An alternate cast steel crankshaft meeting original Ford Kent dimensions and weight is permitted.

Weight: 24 lbs. 8 oz. Minimum
Max Stroke (at piston): 3.056" +/- .004"
Crankshaft pulley: unrestricted

The crankshaft from the Cortina engine may be used.

The crankshaft from the Fiesta engine may be used.

The crankshaft may be shot peened.

l. Flywheel

1. Weight with ring gear: 15.5 lbs minimum.
2. The flywheel may be machined to reduce weight to the above minimum weight. Flywheel locating dowels are permitted.
3. Weight may be added to the flywheel, providing it is added ONLY to the existing clutch bolt holes, i.e., single cap screws or set screws. No continuous material shall be used.
4. An alternate flywheel, part # JAE1600 is also allowed at the above weight of 15.5 lbs.

m. Carburetor

Weber 32/36 DGV or Holley 5200

Venturi diameter: Primary: 26mm
Secondary: 27mm

It is permitted to:

1. Fit any jets (including accelerator pump discharge nozzle) as long as no modifications to the carburetor body are required.
2. Modify or substitute the external throttle linkage.
3. Fit internal and/or external surge pipes.
4. Remove the air cleaner
5. Fit velocity stacks
6. Remove the choke butterflies and linkage.
7. Use an alternate carburetor gasket provided it is the same thickness as the original gasket and doesn't exceed the manifold opening dimensions
8. Modify the carburetor housing for the installation of throttle shaft bearings provided the modification serves no other purpose.

n. Fuel Pump

Unrestricted

o. Exhaust Manifold

Unrestricted

p. Lubrication System

Lubrication system is unrestricted; any oil pump and oil sump permitted; dry sump is permitted. Localized machining of the cylinder block is permitted to allow fitting of the oil pump. Dry sump system is permitted.

q. Cooling System

Cooling system is unrestricted. Any radiator, fan, water pump and drive belt permitted Pump/fan/generator drive belt: Unrestricted

r. Electrical Equipment

Distributor: Distributors are unrestricted provided the original drive, location, and housing are retained. The distributor is defined as the component that triggers the LT current and distributes the HT current. The ignition timing may only be varied by vacuum and/or mechanical means. It is prohibited to use any other method or component to trig-

ger, distribute, or time the ignition. The vacuum advance mechanism may be removed, and the distributor advance plate may be secured by soldering or welding or by suitable fasteners. The advance curve and advance springs are unrestricted. Generators/ Alternators: not required. All other electrical components are unrestricted.

s. Miscellaneous

1. The timing chain/sprocket cover may be altered or replaced.
2. The use of the following non-standard replacement parts is permitted provided their use does not result in any unauthorized modification of any other component:
 - A. Fasteners - nuts, bolts, screws, studs, etc. Intake manifold fasteners may be of either a socket head or hex head configuration, and must be 5/16" diameter.
 - B. Gaskets, except head gasket.
 - C. Washers.
 - D. Seals.
 - E. Connecting rod, crankshaft, and camshaft bearings of the same size and type as original. Normal oversize/undersize bearings are permitted. This does not allow reducing the bearing surface area by reducing the width of standard bearings.
 - F. Spark plugs.
 - G. Rocker pedestals that are of the same material and dimensionally identical (i.e., shaft location, offset, etc.) to the original components may be used.
3. Mechanical tachometer drive is permitted.
4. The crankcase breather may be altered or removed.
5. The standard rocker cover may be altered to provide for crankcase ventilation, and the filler cap may be altered or replaced. Valve or rocker covers may be substituted, provided that the replacement cover affords no additional function than that of the original stock cover. (relocated text from 8 below)
6. The crankshaft and main bearing caps may be treated with salt-bath nitriding cover under SAE specification AMS 2755A (tuftriding, etc.)
7. Any oil or lubricants may be used.
8. Water pump, fan, and generator/alternator pulley(s) are unrestricted.
9. Exhaust Outlets
Exhaust outlets on cars registered after January 1, 1986 shall not extend more than 60 cm (23.60") behind the centerline of the rear axle and shall be positioned between 10 cm (3.9") and 60 cm (23.6) from the ground, measured to the bottom of the exhaust pipe.
Exhaust Outlets: Cars registered prior to January 1, 1986.
 - A. It is recommended that all exhaust outlets be no longer than 60cm (23.60") behind the centerline of the rear axle and positioned between 30cm (11.8") and 60cm (23.6") from the ground.
 - B. For cars unable to comply with the above rule (A.), they shall have a support bracket that attaches within six (6) inches of the outlet end, and the support bracket shall extend no more than thirty (30) degrees from vertical to the rear. Beginning January 1, 1986, it is mandatory for all F1600 cars.
10. Fuel - *F1600 cars powered by the Ford Kent engine are permitted to use 100LL Aviation Fuel that is unmodified or treated in any manner.*

2.1.12. Cortina Engine

All of B.12 applies to the Cortina engine except as specified in this section. Components shall not be interchanged between the Kent and Cortina versions of the engine unless specifically authorized.

a. Compression Ratio

Maximum compression ratio: 10.0 to 1. The following specifications are used in determining compression ratio:

- 1.64cc - top ring to top of piston
- 5.60cc - head gasket.

Minimum unswept volume per cylinder:

- 44.4cc (original engine with standard pistons)
- 45.1cc (original engine with .030" o/s pistons)

b. Block

The 1600 Pinto block, P/N DIFZ-6010-C, may be used as a replacement for the Cortina block; Standard Pinto tap-pets, P/N DORY 6500A and DIFZ 6500A may also be used when this block is used as a Cortina replacement.

2.1.13. Honda Fit 1500 (L15A7) Engine

a. General

1. **No modifications to this engine are allowed** except where specifically authorized within these rules. This includes, but is not limited to, all fuel injection and engine management components, electrical, cooling and lubrication systems. All systems are subject to test procedures and must conform to OEM specifications as stated in the Honda Fit factory service manual, Honda PN 61TK600 and all superseding years, or as specified in these rules. The factory service manual or its equivalent is required to be in the possession of each entrant. The manual may be in the form of printed material, microfiche, CDs, DVDs and/or Internet access to manufacturer sponsored web-based databases.
2. Permitted engine maintenance includes the replacement, but not modification, of external engine and engine systems parts.
3. All rubber fluid lines may be replaced with braided metal-covered (Aeroquip type) lines. Hose clamps may be installed on the rubber oil lines.
4. No balancing, lightening, polishing or other modification of moving parts of the engine is permitted.
5. Only stock Honda manufactured gaskets and seals as specified in the Honda Fit factory service manual are permitted (Including, but not limited to, head gasket, intake runner gaskets and O-rings, restrictor plate gasket, and intake and exhaust gaskets) - except where specifically authorized within these rules.
6. For all Honda part numbers in these specifications, superseding part numbers are considered equivalent.

b. Block

1. The only permitted cylinder blocks are Honda PN:
11000-RP3-810 (2009-2010)
11000-RTW-810 (2010-2012)
2. Honing of cylinders is permitted to a maximum diameter of 73.065 mm (2.8766 inches). Fitting of cylinder sleeves is prohibited. Re-boring to over size is prohibited.
3. Block must use stock main bearing caps, girdle and hardware as supplied.
4. Minimum deck height from crank centerline: 220.00 mm (8.661 inches).

c. Crankshaft

1. The stock Honda Fit crankshaft, Honda PN: 13310-RB1-000, must be used with no modifications allowed.
2. Minimum weight: 27.7 lbs. No pilot bearing, pulser or hardware.
3. Maximum stroke at piston: 89.55mm (3.526 inches)
4. Main and rod bearings must not be modified in any way. OEM bearings must be used from within the standard range as allowed in the Honda Fit factory service manual.
5. The crank pulser must not be altered in any way.
6. The crank pulley/balancer must not be altered or modified in any way.
 - a. Minimum weight: 3.90 lbs.
 - b. Honda PN: 13810-RB0-003.

d. Connecting Rods

1. Stock Honda Fit connecting rod must be used PN: 13320-RB1-000.
2. Minimum connecting rod weight with cap and bolts: 280.0 grams (9.88 ounces).
3. Maximum connecting rod length center to center: 149.05mm (5.868 inches).

e. Pistons

1. Honda Fit OEM standard size pistons, PN: 13010-RB1-000, or Honda Fit OEM 0.25mm oversized pistons, OEM: 13020-RB7-Z00 must be used.
2. Piston dimensions and weights:
 - a. Maximum standard piston diameter, measured at a point 16mm from the bottom of the skirt: 73.240mm (2.8834 inches)
 - b. Centerline of wrist pin to crown maximum: 26.21mm (1.032 inches).
 - c. Maximum overall height from skirt to crown edge: 47.80mm (1.882 inches).

- d. Minimum weight: 198.0 grams (6.984 ounces).
 - e. Minimum weight of piston pin: 66 grams (2.25 ounces).
 - f. Combined minimum weight of piston, piston pin and connecting rod: 543.5 grams (18.85 ounces).
3. Piston rings must be as used in the Fit engine. Two compression rings and one 3 piece oil control ring must be used.
- a. The standard ring pack PN 13011-RB1-004 (Riken) or 13011-RB1-006 (Nippon), or the oversize ring pack, PN 13021-RB7-Z01 (Riken) or 13021-RB7-Z02 (Nippon).
 - b. No modification of the piston is permitted for the installation of rings.
 - c. Ring groove widths.
 - Top ring groove: 1.04mm (0.0409 inches) +/- 0.01mm.
 - Middle groove: 1.02mm (0.04016 inches) +/- 0.01mm.
 - Oil ring groove: 2.00mm (0.07874) +/- 0.01mm.
 - d. Ring gaps must be from 0.006 inch to 0.024 inch.
- f. Cylinder Head**
- 1. The only permitted heads are Honda PN:
 - 12200-RB0-G00 (2009-2010) (US spec)
 - 12200-RP3-A00 (2010-2012) (US spec)
 - 12200-RB0-000 (Japan Spec)
 - 2. The gasket face of the cylinder head may be resurfaced to a service limit of 0.2mm (0.008 inches) based on a height of 120.0 mm (4.720 inches). However, the maximum compression ratio of 10.55:1 may not be exceeded.
 - 3. The cylinder head must not be ported, polished or machined. The original casting must not be modified in any way or polished.
 - 4. Head gasket to be stock Honda Fit PN: 12251-RB0-004. Minimum compressed thickness of 0.76 mm +/- 0.05mm.
 - 5. Cylinder head breather restrictor must be used as supplied by HPD, unmodified. PN: 15262-F21S-A200; Or Fast Forward, Fast Forward PN: FF200-503.
- g. Camshaft**
- 1. The only permitted camshaft is PN: 14110-RB1-J00; must not be modified.
 - 2. The CMP pulse (cam trigger) plate must be as supplied, Honda PN 14221-RB0-003.
 - 3. The camshaft and crankshaft sprockets must be as supplied, Honda PNs: 14211-RB0-J00 and 13621-RB0-003, respectively. Cam timing must not be altered; the timing chain must be installed as specified in the Honda Fit factory service manual. The timing chain/sprocket cover and crankshaft pulley may not be altered. With the engine at TDC (No. 1 cylinder), the "UP" mark on the camshaft sprocket must be at the top and the TDC grooves on the camshaft sprocket must line up with the top edge of the cylinder head.
 - a. Timing chain Honda PN: 14401-RB1-003.
 - b. Case assembly, chain (sprocket cover) PN: 11410-RB1-000
 - c. Pulley comp, crankshaft, PN: 13810-RB0-003
 - d. Cam timing at lobe centers: (at 1mm after opening to 1mm before closing).
 - i. Exhaust: 119 degrees, +/-1.0 degree.
 - ii. Intake VTEC on: 111 degrees, +/-1.0 degree.
 - 4. Camshaft profile and lobe centers shall be checked using the official procedure published by the SCCA.
 - 5. Cam lobe heights: Intake, Primary: 35.240mm, secondary: 36.200mm, exhaust: 35.490mm.
 - 6. Valve lift measured at the retainer:
 - a. Exhaust: 9.200mm
 - b. Intake VTEC off: 8.680mm
 - c. Intake VTEC on: 9.900mm

7. Valve rockers must not be modified in any way.
 - a. Honda PN: 14620-RB1-010 Arm Assy, rocker.
8. The VTEC system must be stock. The VTEC activation valve must be stock. The HPD ECU will activate the VTEC at 5200 RPM. Honda PN: 15810RB0-G01.

h. Valves

OEM valves must be as used in the Fit.

1. Dimensions
 - a. Inlet PN: 14711-RB0-000 Exhaust PN: 14721-RB0-000
 - b. Maximum diameter: Inlet: 28.15mm Exhaust: 23.15mm
 - c. Maximum overall length: Inlet: 119.15mm Exhaust: 117.85mm
 - d. Minimum stem diameter: Inlet: 5.45mm Exhaust: 5.42mm
2. Valve location or angle must not be moved.
3. Reshaping of the valves is strictly prohibited.
4. Valve guides may be replaced provided the position of the valve is not changed and the replacement guides are Honda OEM parts.

Inlet PN: 12204-PJ7-305 (over size)

Exhaust PN: 12205-PJ7-305 (over size).
5. It is permitted to replace or re-cut valve seats provided the valve seat angles are stock Honda three angle cut per the Honda Fit factory service manual.
6. Valve stem installed height must be per The Honda Fit factory service manual:

Intake maximum: 46.8mm.

Exhaust maximum: 46.9mm.
7. Valve stem seals must be Honda OEM parts.

Honda PN: Intake: 12210-PZ1-004 seal A.

Honda PN: Exhaust: 12211-PZ1-003 or 12211-PZ1-004 seal B.

i. Valve Springs

1. Valve springs are Honda OEM as specified in the Honda Fit factory service manual.
 - a. Intake PN: 14761-RB1-003, free length: 48.55mm.
 - b. Exhaust PN: 14762-RB1-007, free length: 54.52mm.
2. Valve spring shims are not permitted.

j. Compression Ratio

The maximum compression ratio is 10.55 to 1 utilizing Honda Fit factory service manual limits. Carbon may be **removed**.

k. Intake Manifold and Fuel System

1. The lower manifold must be stock Honda Fit parts. It is not permitted to add or remove material. No coating is permitted on the exterior or interior of the manifold. Honda PN: 17100-RB1-000
2. The upper manifold, air box and throttle body assembly must be used as delivered from *Honda*, HPD, or Fast Forward as noted below. External throttle return springs are unrestricted.
 - a. Intake manifold: HPD PN: 17210-F21S-A210; Fast Forward PN: FF200-201.
 - b. Throttle body: Honda Fit: PN: 16400ZZ5024; HPD PN: 16400ZZ5024; Fast Forward PN: FF200-104.
 - c. Throttle lever: HPD PN: 17330-F21S-A210; Fast Forward PN: FF200-101.
 - d. Air filters are unrestricted. All air entering the engine must pass through the air filter prior to entering the throttle body. No devices such as, but not limited to, air horn(s), trumpet(s), bell mouth(s), velocity stack(s), vortex generators and or turning vanes are permitted inside the air filter or between the air filter and the throttle body.
 - e. No coating is permitted on the exterior or interior of the manifold. A thermal wrap may be used on the exterior of the manifold, but it must be easily removable for inspection of the manifold.

3. All gaskets and sensors utilized on the inlet manifold from head to throttle body must be Honda Fit OEM or HPD supplied - or Fast Forward as noted below.
 - a. Gasket In. manifold: HPD PN: 17105-RB0-004, Honda Fit OEM.
 - b. Gasket, EGR chamber cover: HPD PN: 17146-RB0-004, Honda Fit OEM.
 - c. Gasket In. port: HPD PN: 17115-RB0-007, Honda Fit OEM.
 - d. Gasket, restrictor: HPD PN: 17399-F21S-A200 HPD; Fast Forward PN: FF200-109. Two required.
4. The fuel rail must be as supplied by HPD. Injectors must be stock Honda Fit OEM parts (PN 16450-RNA-A01). The fuel pressure regulator may be the unit supplied by HPD or any alternate as long as the fuel pressure regulator serves no additional purpose. Injectors must be stock Honda Fit OEM parts (PN 16450-RNA-A01).
5. The Honda Fit engine is required to have an air inlet restrictor supplied by HPD or Fast Forward: HPD PM: 17344-F21S-A201; Fast Forward PN: FF200-110 with internal diameter of 30.5mm and thickness of 3.175mm (0.125 inches) correctly installed within the intake system. **The restrictor may not be modified in any way**; the specified value can not be exceeded in any measurement of the diameter. The restrictor centerline or shape must not be altered. FRP will have go-no go gauges to verify that all competitors are in compliance. *An unmodified HPD gasket must be correctly installed on both sides of the restrictor. Non HPD provided restrictors or gaskets are not allowed.*

I. Fuel Pump

The fuel pump is unrestricted.

m. Exhaust Manifold

1. The exhaust manifold must be as supplied by HPD or Fast Forward: HPD PN: 18150-F21S-A200 or PN: 181850-F21S-B200; Fast Forward PN: FF500-001 or PN: FF500-002.
2. *The exhaust manifold exit may be shortened within HPD specified limits to direct the tail pipe as necessary.* The tail pipe must be made from a single wall thickness tubing for its' entire length and may not be swaged, shaped or formed in any way other than bending required for fitment. *The exhaust pipe must maintain a 2 inch outside diameter from the manifold exit.*
3. The Lambda sensor may be placed anywhere in the exhaust system after the required exhaust manifold.
4. Exhaust coatings and wraps and heat shields may be used to control engine bay temperatures and protect other components.

n. Lubrication System

1. The oil pan, baffle plate, and scavenge pump filter fittings must be as supplied by HPD or Fast Forward as noted below. No modifications are permitted.
 - a. Oil pan: HPD PN: 11200-F21S-A210 or PN: 11200-F21S-C240; Fast Forward PN: FF100-201A or PN: FF100-201B.
 - b. Oil pan baffle plate: HPD PN: 11221-F21S-A210; Fast Forward PN: FF100-202.
 - c. Oil scavenge pump filter fittings (2 required): HPD PN: 15180-F21S-A210; Fast Forward PN: FF100-204.
2. Oil feed pump must be stock Honda Fit. No modifications are permitted. Oil pressure may be adjusted for wear.
 - a. The oil pressure sensor location must be as supplied by HPD.
 - b. It is recommended that oil pressure be maintained at the factory service manual specification.
3. The scavenge pump and internal scavenge pump parts must be as supplied from HPD or Fast Forward as noted below. No modifications are permitted.
 - a. Rotor length: 25.400mm (1.000 inches)
 - b. Rotor outside diameter: HPD 44.400mm (1.748 inches); Fast Forward 40.640mm (1.600 inches).
 - c. Scavenge pump rotor set: HPD PN: 15450-F21S-A20; Fast Forward PN: FF100-110.
 - d. Oil pump: HPD PN: 15100-F21S-A200; Fast Forward PN: FF100-100A.
 - e. Scavenge pump cartridge: 15111-F21S-A21; Fast Forward PN: FF100-127.
 - f. Scavenge pump port A: HPD PN: 15137-F21S-A20; Fast Forward PN: FF100-101.
 - g. Scavenge pump port B: HPD PN: 15139-F21S-A20; Fast Forward PN: FF100-102.
 - h. Scavenge pump shaft: HPD PN: 15510-F21S-A20; Fast Forward PN: FF100-103.

- i. Scavenge pump front cover: HPD PN: 15070-F21S-A21; Fast Forward PN: FF100-104
 - 4. Scavenge drive pulleys must be as supplied by HPD. Drive belt manufacture is unrestricted provided the belt type and dimensions are as specified by HPD.
 - 5. Hose routing and filter system are unrestricted.
- o. Cooling System**
- 1. Water pump and water pump pulley must be stock Honda Fit parts. No modifications are permitted.
Honda PN: 19200-RB0-003 Pump, water.
Honda PN: 19224-RB0-000 Pulley, water pump.
 - 2. The water inlet and outlet at engine must be as supplied by HPD. The thermostat is unrestricted provided the housing is not modified. The thermostat bypass may be plugged.
 - 3. Drive belt manufacture is unrestricted provided it is designed for use with Honda Fit crank pulley.
 - 4. Radiator is unrestricted.
- p. Electrical Equipment**
- 1. The ECU and engine electrical harness must be as supplied by HPD, [Indy Wiring](#), [Zentec](#), [Diebold Racing](#), [Ray Race Cars & Spectrum Race Cars](#). No modifications are permitted. [Other Harnesses may be approved, but check with FRP Prior to using.](#)
Honda's [HPD LC1 ECU](#) is approved as an alternate.
 - 2. The ECU will be a sealed unit supplied by HPD. The ECU maps and inputs must not be modified The ECU is capable of being swapped in the case of a protest.
 - 3. Ignition coils must be stock Honda Fit, PN: 30520-RB0-003. No modifications are permitted.
 - 4. **All Sensors** related to engine operating parameters and/or supplied by HPD must be used. These sensors, their locations and mounts, and their wiring harness leads may not be altered or "piggy backed". Any sensors required for analog type gauges must be in addition to the HPD supplied sensors. For qualifying and race Any sensor other than an approved sensor in the original factory location must be disconnected.
 - 5. The alternator must be stock Honda Fit PN: 31100-RB0-004 or HPD part #3100-F21S-A200. The alternator drive pulley must be stock. Alternator connections must be through the HPD engine electrical harness only. The alternator must not be disabled and must be accessible to FRP officials.
- q. Flywheel**
- 1. The stock Honda Fit flywheel must be used. No modifications are permitted except for normal resurfacing for clutch wear.
 - a. Stock Honda flywheel PN: 22100-RB0-005.
 - b. Minimum weight with ring gear: 14.4 lbs.
 - 2. The stock Honda Fit clutch must be used. No modifications are permitted.
 - a. Honda PN: 22300-RB0-005; Quicksilver PN: QSHDR-411.
 - b. Minimum weight without friction disk: 7.0 lbs.
 - 3. Only stock Honda friction disk or friction disk from Quicksilver Race Engines may be used. No modifications are permitted.
 - a. Honda PN: 22200-RB0-005.
 - b. Weight of new friction disk: 2.1 lbs.
- r. Miscellaneous**
- 1. All emission control devices must be removed and blocked off by the blanking plate provided by HPD, except the VTEC activation valve. The VTEC activation valve must be retained; it must be functioning.
 - 2. Air filter is unrestricted.
 - 3. The use of unleaded premium "pump" gas: 91 – 93 RON is recommended. However consult the Series Rules and Technical bulletins for fuel specifications for each event
 - 4. The use of the following non-standard replacement parts is permitted provided their use does not result in any unauthorized modification of any other component.
 - a. Fasteners – nuts, bolts, screws, washers, studs, etc. Head bolts, rod bolts, flywheel bolts, and crank pulley bolt must be used as provided by Honda and HPD.

- b. Gaskets and seals, except those specified in the above rules.
- c. Spark plugs.
- d. Mechanical tachometer and analog gauges.
- e. Oil and lubricants are unrestricted. HPD strongly recommends the use of oil and lubricants as described in the Honda Fit factory service manual.
- f. The oil filler cap may be removed and plugged.

2.1.14. Ford NE series and Pinto Engines

The Ford 2 liter single overhead camshaft "NE" series engine and the 1971-74 Pinto/Capri 2 liter single overhead camshaft engine shall conform to the following specifications. The nominal bore is 90.84mm and the nominal stroke is 76.95mm (Note: All blocks shall contain casting number HM6015BA, HM6015AA, HM6015BB, HM6015AB, HM6015DA, or HM6015AD. Dashes in the casting number are not relevant.). Production tolerances are permitted providing the total swept volume does not exceed 2000cc.

- a. The rockers shall remain entirely unmodified. Alternate manufacturers may be used as long as the original materials and dimensions are the same. Camshafts must be from Ford Motor Company, or Crower part #E57553 FF2000, or any camshaft that is a replica of the original and of the same material may be used. Camshaft geometry shall be stock. An alternate optional camshaft, Elgin part number 2000FC, may be used only in the original iron head. Regrinding camshaft lobes is permitted as long as the camshaft lobe center is $112^\circ \pm 2^\circ$. Offset keys are permitted. Tufriding or Parkerizing is permitted. Maximum valve lift at determined points by camshaft rotation will be established. The use of a low rate substitute valve spring is permitted. Load characteristics of special checking spring: twelve (12) lbs., at 1.417 inches, thirty (30) lbs., at 1.000 inches. An adjustable camshaft sprocket which retains the same number of teeth and pitch as the stock sprocket may be used.
- b. A standard crankshaft shall be used or any crankshaft that is a replica of the original crankshaft and of the same material may be used. Spot machining to achieve balance is permitted. Tufriding, Parkerizing, shot peening, shot blasting, and polishing are permitted. Minimum weight: twenty-seven point five (27.5) lbs.

See Tables - page 21

- c. The flywheel shall be a standard component or the approved alternate Elite-001. The minimum weight is 10.5 lbs. with ring gear. The flywheel may be machined to achieve minimum weight. Spot machining to achieve balance is permitted. Flywheel bolts are free and locating dowels are permitted. A 1600 GT starter ring may be fitted. The use of any single plate clutch is permitted provided no modification is made to the flywheel other than changing the points of attachment of the clutch to the flywheel. Carbon fiber clutches are not permitted.
- d. Maximum compression ratio will be controlled as follows:
 1. Minimum Cylinder Head combustion chamber volume 49cc (not including head gasket). Polishing and/or tooling of the cylinder head to achieve only the required combustion chamber volume is permitted.
 2. Standard Ford gasket, Fel-Pro #8361PT, or Ferrea part number G50100 may be used. Gaskets will have a minimum thickness of 0.9mm, minimum diameter of cylinder aperture of 92mm.
 3. Pistons shall not protrude above cylinder block surface at TDC.
- e. It is permissible to reshape inlet and exhaust port by removal of metal within limits. Addition of material in any form is prohibited. Maximum diameter of the inlet port at the manifold head is face 39.5mm. Maximum dimensions of exhaust port at manifold face 35.5mm x 27mm. The distance between the valve centers and the angles of the valves shall not be altered.
- f. Pistons shall be standard Ford Mahle, AE Hepolite, CP, or J&E. Pistons must be unmodified in any way except for balancing and as detailed herein.

The following combinations are permitted:

1. Mahle piston P/N 80HM6102LA with rings, pin, connecting rod (with bolts), but without bearings: Minimum permitted weight = 1332.5 grams.
2. Mahle piston P/N 85HM6102DA with rings, pin, connecting rod (with bolts), but without bearings: Minimum permitted weight = 1240 grams.
NOTE: This piston may have either casting #90V108 or #90V118.
3. AE Hepolite piston P/N 21426, casting P/N 21426 (AE Hepolite) with rings, pin, connecting rod (with bolts), but without bearings: Minimum permitted weight = 1240 grams.
4. CP piston P/N IV 2.0 LTR with rings, pin, connecting rod (with bolts), but without bearings: Minimum permitted weight = 1240 grams. Part number and lvey logo stamped on wrist pin bosses.
5. JE piston P/N M-6102-B200 with rings, pin, connecting rod (with bolts), but without bearings: Minimum permitted weight = 1240 grams.

6. Wiseco piston P/N WD07253 as supplied by Quicksilver with rings, pin, Crower connecting rod P/NSP 93221 (with bolts), but without bearings: Minimum permitted weight; 976 grams.

NOTE: M-6102-B200 piston assembly is now made by JE and is visually different. I.D. Marks: M-6102-B200, Ford racing logo. All marks pin stamped on wrist pin bosses.

Rings are unrestricted provided that:

- A. One oil control and two compression rings are used.
- B. No modification is made to the piston for the installation of the rings.

Localized machining of the gudgeon pin bosses to achieve balance and weight by simple machining; all external surfaces, dimensions, and profiles shall remain standard with the exception of the top surface of the piston crown which may have simple machining to achieve balance, and as required in Section 9.1.1.B.3.d.

- g. Valves may be of Ford manufacture or Ferrea part numbers VSOIN200 and VSOEX2000. Valves shall remain standard; no reprofiling or polishing is permitted.
 - The original forty-five (45) degree seat angle shall be maintained.
 - Maximum face diameter inlet 42.2mm.
 - Maximum face diameter exhaust 36.2mm.
 - Maximum valve stem diameter 8.4mm.
- h. Full connecting rods may be standard Ford, Cosworth, Oliver, or Crower. The approved Crower part numbers are SP93230B-4 or SP93230PF-4. Any rod bolts may be used. Floating piston pins may be used. Standard rod length must be 5.00 inches (+.005" -.010"). Alternative Crower connecting rod part number SP93235B-4 is permitted. Its length must be 5.700 inches (+ or .005 - .010"). This rod may be used only with Wiseco piston part number WD-06526 as supplied by Quicksilver above. Any rod bolts may be used. Floating piston pins may be used. Machining is permitted to remove metal from the balancing bosses to achieve balance only. Tufftriding, Parkerizing, shot peening, shot blasting, polishing, etc., are permitted.
- i. Maximum valve lift against cam angle with zero tappet clearance: (Lift measured in mm)
- j. Engines will be mounted upright, and aligned fore and aft in the chassis.
- k. A single carburetor only will be used on a standard inlet manifold. The carburetor will be a Weber 32/36 DGV 26/27mm venturi, its origin being from a 1600 GT "Kent" or 2000 SOHC NE engine. The Holly 5200 32/36 or the Weber 38DGES (27mm venturi) carburetor also may be used; carburetor with the swaged fuel inlet fitting shall be replaced by drilling and tapping the carburetor body for a threaded fitting. The air cleaner may be removed and a trumpet fitted, and jets may be changed, both throttles may open together, cold start devices and diffused bar may be removed, internal and external antisurge pipes may be fitted, and seals on emission control carburetors may be removed. The bottom of the lower column portion of the auxiliary venturi may be machined for purposes of high speed enrichment. No other modifications are permitted. Chokes (venturi) shall remain standard and no polishing or profiling is permitted.
- l. The addition of material by any means to any component is prohibited.
- m. It is permitted, as a means of repair, to replace damaged valve seats and cylinder bores by replacement cast iron valve seat inserts and cast iron cylinder liners; valve guides may be replaced with cast iron or bronze, all to standard dimensions. Repairs to the cam towers to facilitate replacement of cam bearing and/or replacements of broken or cracked towers is permitted as long as the cam bearing center line is not changed and that one original cam tower is retained. Line boring of cam bearing caps is permitted.
- n. Balancing of reciprocating and rotating parts is permitted only by removal of metal from locations so provided by the manufacturer.
- o. Nonstandard rocker covers are permitted providing they in no way improve the performance of the engine.
- p. Standard valve spring retainers shall be used, and single valve springs only are permitted. Shims are permitted, and valve springs are otherwise free.
- q. Exhaust system and manifold are unrestricted, within FRP and SCCA safety regulations.
- r. Lubrication system is unrestricted; dry sump is permitted. Localized machining of the cylinder block is permitted to allow fitting of the oil pump.
- s. Oil coolers are unrestricted.
- t. Cooling system unrestricted. The radiator, if housed in or incorporating a cowl air scoop deflector, shall comply with body regulations.
- u. Fuel Pump: Unrestricted.
- v. Distributors are unrestricted providing they retain the original drive and location. The distributor is defined as the component which triggers the L.T. current and distributes the H.T. current. The Ignition Timing may only be varied by vacuum and/or mechanical means. It is prohibited to use any other method or component to trigger, distribute, or time the ignition.

- w. Only the standard inlet manifold shall be used.

The ports may be reshaped by the removal of metal as long as the following dimensions are maintained: maximum size at head face = 1.437" (36.5mm), maximum size at carburetor flange = 3.405" (86.5mm) x 1.595" (40.5mm). The carburetor seat face may be machined to horizontal in the fore to aft plane. The diameter of the ports may exceed the above listed dimensions if the casting bore is untouched and in its original state. The water passages in the inlet manifold may be plugged. Holes in the inlet manifold resulting from the removal of emission/vacuum lines shall be plugged.

- x. Gaskets and seals are unrestricted except for the cylinder head gasket that has the requirements listed in B.15.d.2. and the intake gasket. The intake gasket thickness must not exceed 1.1mm. Intake gasket is not to be construed as a spacer.
- y. Pump, fan, and generator drive pulleys are unrestricted.
- z. The crankcase breather may be altered or removed, but all breathers shall discharge into a catch tank.
- aa. Mechanical tachometer drives may be fitted.
- bb. Generators are optional.
- cc. Standard oversize and undersize bearings are permitted. This does not allow reducing the bearing surface area by reducing the width of standard bearings.
- dd. The use of nonstandard replacement fasteners (nuts, bolts, screws, studs, and washers) which are not connected with or which do not support the intake manifold or any moving parts of the engine is permitted.
- ee. Only modifications or additions specifically covered by these regulations are permitted. All engine components not covered by these regulations shall remain completely standard and unmodified. When a system is specified to be "unrestricted" (e.g. paragraphs r and t), the restrictions of this paragraph do not apply.
- ff. The use of the Fast Forward aluminum cylinder head is permitted. The following dimensions must be maintained.

Intake port maximum volume	70.0 cc.
Exhaust port maximum volume	52.0 cc.
Intake port surface to exhaust port surface	5.580 +/- 0.020 inches
Intake valve center line to (adjacent) intake valve center line	4.015 +/- 0.015 inches
Exhaust valve center line to (adjacent) exhaust valve center line	4.015 +/- 0.015 inches

The machine tool marks in the intake and exhaust ports must remain untouched for 0.750 inches from the respective gasket surfaces.

- gg. Any spark plugs may be used.

**Ford NE series and Pinto Engines
Section b - crankshafts**

Standard Camshaft				
Angle	Intake		Exhaust	
	Opening	Closing	Opening	Closing
0	10.442	10.442	10.442	10.442
5	10.36	10.36	10.36	10.36
10	10.11	10.11	10.11	10.11
15	9.69	9.69	9.69	9.69
20	9.11	9.11	9.11	9.11
25	8.37	8.37	8.37	8.37
30	7.45	7.45	7.45	7.45
35	6.38	6.38	6.38	6.38
40	5.17	5.17	5.17	5.17
45	3.86	3.86	3.86	3.86
50	2.59	2.58	2.58	2.59
55	1.5	1.47	1.47	1.5
60	0.86	0.81	0.81	0.86
65	0.65	0.56	0.56	0.65
70	0.54	0.43	0.43	0.54
75	0.46	0.33	0.33	0.8
80	0.37	0.19	0.19	0.37
85	0.26	0.08	0.08	0.26
90	0.2	0.01	0.01	0.2

Alternate Camshaft				
Angle	Intake		Exhaust	
	Opening	Closing	Opening	Closing
0	11.182	11.182	10.149	10.149
5	11.102	11.092	10.07	10.071
10	10.853	10.821	9.831	9.829
15	10.423	10.363	9.426	9.415
20	9.821	9.721	8.854	8.826
25	9.069	8.916	8.117	8.073
30	8.177	7.955	7.205	7.154
35	7.131	6.85	6.132	6.071
40	5.96	5.624	4.92	4.866
45	4.702	4.313	3.611	3.6
50	3.425	3.01	2.346	2.38
55	2.242	1.851	1.325	1.406
60	1.278	0.994	0.722	0.825
65	0.642	0.509	0.488	0.604
70	0.334	0.307	0.385	0.524
75	0.215	0.208	0.303	0.461
80	0.134	0.13	0.224	0.404
85	0.064	0.063	0.146	0.343
90	0.022	0.024	0.09	0.279

2.1.15. Ford Zetec Engine

The Ford Zetec ZX3 engine shall conform to the following specifications and may be modified only as specifically allowed. **If these specifications do not explicitly allow a modification, then it may not be done.** The philosophy of the Zetec engine in F2000 is to allow limited engine rebuilds but no performance modifications to the engine. Blue printing, balancing, head porting, polishing, etc. are strictly prohibited and against the spirit of the Zetec formula. Where Ford part numbers are specified, normal industry part number supersession is expected and the superseding part numbers are automatically included.

- a. The cylinder head may not be ported or polished. Machining the cylinder head is not permitted except as specified in these rules. A standard three- angle "production" valve job is required and the only allowed angles are those defined in the Ford factory manual. The intake valve seats must be 30° 45° 70° with the 45° face a minimum 1.5 mm wide. The exhaust valve seats must be 30° 45° 55° with the 45° seat 1.5 mm wide minimum. Valve seats and guides may be replaced providing that they remain in the original stock locations. The camshaft, valves, springs, and shim/bucket components must be original Ford parts and may not be modified in any way. Only original unmodified Ford parts may be used for direct replacement. The camshafts must remain as ground by Ford; no polishing is permitted. The head may not be surfaced or milled beyond the minimum thickness of 5.230" measured between the cam cover seating surface and the lower plane of the head. Only the Ford #RFYS4E6090AC or RFYS4E6090AD head is allowed. The only allowed camshafts are the Ford #L913B YSAA intake and #L913B C2B exhaust. The original, unmodified Ford camshaft and crankshaft timing pulleys must be used. Required camshaft timings are as follows:

Intake centerline 116-117 degrees ATDC

Exhaust centerline 106-107 degrees BTDC

- b. Only original Ford or Sealed Power H872cp pistons may be used. Crankshaft, and rods may be replaced only with standard original Ford replacement parts. The crankshaft, rod and main bearing journals may be reground or polished for the purpose of installing oversize main or rod bearings. The big end of the connecting rod may be honed to fit .002 inch larger rod bearings. Connecting rod bearings may be replaced with unmodified bearings which are specifically designated for use in this engine. The required original crankshaft main bearing journal dimension is 2.282-2.283 inches and the required original crankshaft rod journal dimension is 1.846-1.847 inches. The corresponding main journal dimensions for oversized bearings are either 2.273-2.274 inches or 2.263-2.264 inches; the corresponding rod journal dimensions for oversized bearings are either 1.837-1.838 inches or 1.827-1.828 inches. The crankshaft centerline to deck dimension is 8.378 inches and may not be altered. The main bearing housing bore is 2.452-2.453 inches and the rod housing bore is 1.9642-1.9650 inches. Only original Ford rod bolts with a minimum weight of 24.6 grams or ARP rod bolts with a minimum weight of 23.5 grams may be used.
- c. Only original stock Ford replacement piston rings (part number 2S4Z6148AA) or Hastings Rings (part number 2M4887 Std) may be used. The ring end gaps may not be altered and must remain as manufactured. All of the rings must be installed including the complete oil scraper assembly. The piston bore may be honed solely to allow piston ring seating. The first and second compression rings must be installed in the positions designated by the manufacturer.
- d. All surfaces on the head, block, rods, pistons, and crankshaft must remain as manufactured by Ford and may not be altered in any way unless specifically provided for in these rules. The original casting marks and cast surfaces must remain as-cast and also meet all of the Ford design values and tolerances as stated in the Ford factory manual or as delineated in these specifications. The block may not be decked. Only Ford Zetec ZX3 blocks with block numbers #RFYS4G6015AA, or #RFYS4G6015AD or #RFYS4G6015AE are permitted. The blocks may be sleeved however all bore tolerances must remain stock or as otherwise provided for in these rules. The required compression ratio is 9.6:1, the required standard bore is 3.3390–3.3420 inches and the required stroke is 3.461 +/- .004 inches. The maximum bore dimension of 3.3420 inch is intended to allow for cylinder wear only. It is not permitted to machine to this dimension. This measurement will be taken .250 below the block deck where the bore is untouched by the piston ring.
- e. Flywheel: The minimum weight is 8.0 lbs. and any weight removal from the specified flywheel must come from the clutch plate surface. The friction and clamping force surface of the flywheel may be resurfaced. Only the Quarter Master #QM107160 flywheel may be used. It is permitted to install a new ring gear on the flywheel.
- f. Any 7¼ inch single plate or double plate, non-carbon fiber clutch is allowed.
- g. Any oil pan is allowed. The oil pan may not contain an oil scraper between the oil pan and the block. No device in the oil pan may be contoured to the crankshaft assembly to function as an oil scraper nor may any device be closer to the rotating crankshaft assembly than 0.500 inches.
- h. Any three-stage oil pump with a maximum of two scavenge stages is allowed. The maximum scavenge rotor dimensions are 1.600 inches in diameter and 1.375 inches in length. The maximum pressure rotor dimensions are 1.600 inches in diameter and 0.863 inches in length.
- i. The exhaust system manifold tubing OD must be 1.5 inches (as measured 1 inch or more from the face of the head) and the manifold tubes must be a minimum of 24 inches in length and must terminate into a single exhaust pipe through a 4 into 1 collector. The collector angles must be the standard 15 degree bend, (30 degree

included angle) with an exit diameter of 2 inches. The tail pipe must be a minimum of 24 inches in length. The tail pipe includes a muffler, if present, as long as the inlet and outlet pipes of the muffler are the same diameter as the tail pipe. 4 into 2 into 1 exhaust collectors or reduced diameter venturi sections are prohibited.

- j. ECU: The Pectel T2 or the Performance Electronics PE-3 unit is required. The 2018 FRP Pro map is required. When using the Performance Electronics PE-3 ECU, engine sensors must be compatible with the Series provided PE-3 map.
- k. Intake manifold and fuel injection components: The Quicksilver Race Engines (QSRE) intake air scoop, intake manifold, throttle bodies, air horns, fuel rail, injector system, pressure regulator and carbon fiber air scoop with filter are required and must be used with no modifications of any kind unless specifically provided for in these rules. (Due to the aging of the air scoops alternative means of securing the filter will be permitted which may include modifications to the debris tube and other mounting hardware. The air scoop however must have a minimum .430 inch operable air bleed at its rear most point.) The only allowed intake manifold and throttle body combination is the #0138 manifold available through QSRE. Only 19 pound fuel injectors may be used and they may not be modified in any way. Fuel injectors may be replaced only with stock Ford injector part number #0280155887 XS4U-AA or Accel injector part number ACC150819.
- l. The QSRE #1975 intake restrictor must be used and may not be modified in any way. The restrictor internal diameter is 1.340. The restrictor is to be placed between the air scoop mounting flange and the intake manifold.
- m. Engines will be mounted and aligned fore and aft in the chassis
- n. The addition of material by any means to any component is prohibited
- o. Non-standard rocker covers are permitted providing they in no way improve the performance of the engine.
- p. Oil coolers are unrestricted.
- q. A liquid cooling system is mandatory, but radiators are unrestricted. The stock water pump may be modified; electric water pumps are prohibited.
- r. Fuel pump is unrestricted.
- s. Gaskets and seals are unrestricted except for
 1. Cylinder head gasket, Ford part number XS7Z6051CA or Victor Reinz part number 54502
 2. A continuous o-ring of cross-section of 0.100 inches must be fitted to each intake runner groove between the intake manifold and the head which to ensures that no air by-passes the o-ring seal
- t. Pump, fan, and generator drive pulleys are unrestricted.
- u. The use of non-standard replacement fasteners (nuts, bolts, screws, studs, and washers) which are not connected with or which do not support the intake manifold or any moving parts of the engine are permitted.
- v. Any tapered seat 14mm x 25mm (.984 inch) reach spark plugs may be used.
- w. Ford OEM coil P/N 988Z12029A or any other single OEM type replacement coil is allowed.

2.1.16. Transmission

Any transmission may be used with not more than four (4) forward gears and an operational reverse gear. The change gear ratios are unrestricted.

- a. The use of an automatic and/or sequentially shifted gearbox is prohibited.
- b. Electronic and/or electro-mechanical assisted gear change mechanisms are prohibited.
- c. Gearboxes with shafts that are transverse to the longitudinal axis of the chassis are not allowed. The sole exceptions are the gearbox final drive (crownwheel) shaft axis and final drive shafts (half shafts).
- d. All change gears must be located in the case aft of the final drive.

2.1.17. Final Drive

Any final drive unit may be used except:

- a. Drive shall be to rear wheels only.
- b. The differential shall be of standard "open" type and cannot be modified in any way to limit its normal function. Torque biasing, limited slip, and locked differentials are prohibited.
- c. Electronically controlled differentials are prohibited.

2.1.18. Clutch

- a. F1600: The use of any single plate clutch on the Ford Cortina and Kent is permitted provided no modification is made to the flywheel other than changing the points of attachment of the clutch to the flywheel, and provided that it shall have an operable clutch system. Carbon Fiber clutches are not permitted.
- b. The Honda Fit powered F1600 shall use the clutch specified in Section 2.1.13.q.
- c. F2000 see section 2.1.15.f.

2.1.19. Minimum Weight (formerly Series Rule 3)

Competition weight is to be as raced, qualified, or practiced and will include the driver with all driver gear/equipment and not allow for any replenishment of fluids.

F1600:

Ford Cortina Engine: 1110 lbs.
Ford Kent and Honda Fit Engines: 1110 lbs.

F2000:

Pinto Engine: 1190 lbs.
Pinto with aluminum cylinder head: 1190 lbs.
Zetec Engine: 1210 lbs.
Mazda MZR Engine: 1210 lbs

2.1.20. Tires

- a) Competition tires are the Hoosier tires as specified by the Series.
 1. F2000 shall use the following tires: -
Dry Front – 43164 20.5X7.0-13 R60A
Dry Rear – 43285 22.0X8.0-13 R60A
Wet Front – 44185 21.0X6.5-13 W3
Wet Rear – 44196 22.0X8.013 W3
 2. F1600 shall use the following tires:
Dry Front – 43322- 185/60R13 R60A
Dry Rear – 43327- 205/60R13 R60A
Wet Front – 44421- 185/60R13 W3
Wet Rear – 44426- 205/60R13 W3
- b) FRP may choose to change tire compounds during the course of the season.
- c) F2000 and F1600 competitors are limited to six (6) tires, from the start of the first qualifying session through the final race of the weekend.
- d) Tires must be properly **marked by an FRP official**.
- e) In the event of a tire becoming dangerous to race on, the specific circumstances will be reviewed on a case by case basis, by the Technical Director.
- f) In the event of rain, only the rain tires specified in 21(a) will be allowed with no quantity limitations.
- g) No hand grooving of slicks **or rains** is allowed.
- h) Tire warmers are not allowed anytime during the weekend.
- i) Tire treatments, conditioners, or softeners are prohibited.

2.1.21. Competition Adjustments

- a. Engine
 1. All Zetec engines must be sealed. Engines may be sealed by either Elite Engines, **Elan Power**, or Quicksilver Race Engines (QSRE).
 2. F1600 cars using the Honda Fit engine may not use electric fans for engine cooling
 3. Honda Fit 1600 alternate clutch disk permitted as provided by Quicksilver Race Engines (QSRE) part number QSHDR-411
- b. Air Restrictor
 1. The required Intake Air Restrictor on all Zetec motors with a PE 3 ECU is Quicksilver Race Engines Part#1340
 2. The required Intake Air Restrictor on all Zetec motors with a Pectel T2 ECU is the Quicksilver Race Engines Part#1340.
 3. The required Intake Air Restrictor on all Honda Fit motors is HPD 30.5mm
- c. ECU's
IT IS THE DESIRE OF THE SERIES TO ELIMINATE THE PECTEL P2 FROM COMPETITION, BUT USE WILL BE ALLOWED UNTIL SUPPORT OF P2 BECOMES NONVIABLE.

1. Zetec powered F2000 cars using the PE3 ECU, the only allowable ECU map is as installed and password protected by the Series and must be utilized throughout the weekend. It is the participants responsibility to use engine sensors compliant with the official Series map
 2. Zetec powered F2000 cars using the Pectal ECU Map must use the current F2000 Formula Race Promotion(FRP) map. The FRP map will be passcode protected by the Series. The ECU map will be flashed on a regular basis and may well be installed several times each weekend.
 3. The ECU on Honda Fit powered F1600 cars may be replaced by the series as it deems necessary.
- d. Zetec fuel injectors should read stock Ford, an approved alternate is the QuicksilverRace Engines Part # ACCELL 150819.
 - e. As of 2012 in F1600, European spec cars are permitted in the F1600 Series, as approved by the Series.
 - f. F2000 cars must be able to turn the master switch “off” and back to “on” while on the grid without the removal of fasteners or body components.
 - g. All cars must be capable of being lifted using a roll bar mounted tow bar, or a strap must be able to be wrapped around the top of the main roll bar without removing fasteners, or bodywork.
 - h. Brake calipers must be either ferrous or aluminum alloy with no more than four pistons per unit for F1600 and F2000. There can be no more than one caliper per wheel. Pads are free for F2000 and F1600.

2.1.22. Cars Registered Prior To 1/1/86

The following specifications are for cars registered prior to January 1, 1986 and for Technical Inspection only. No cars are to be built to these specifications as of January 1, 1986.

A. Chassis/Frame

The chassis is defined as the frame. It shall be a steel space frame. Monocoque type structures are prohibited. Sheet material affixed to the frame by welding, bonding, or riveting, or by bolts or screws which are six (6) inch centers are defined as stress bearing panels.

The undertray, for safety reasons, shall be a stress bearing panel. Its curvature shall not exceed one (1) inch. The mountings for brake and clutch pedals and cylinders, and for the instrument panel and the bulkhead (panel) behind the driver may be stressbearing. No other stress-bearing panels are permitted.

Brackets for mounting components, such as the engine, transmission, suspension pickups, instruments, clutch, and brake components, and body panels may be nonferrous, of any shape, and fastened to the frame in any manner.

Gussets are defined as of steel, fastened to a maximum of two (2) members, and are specifically permitted.

The firewall portion of the bulkhead (panel) shall extend the full width of the cockpit and be as high as the top of the carburetor. Forward facing air ducts may be installed for the purpose of delivering air directly to the engine area. Air duct openings may be located within the cockpit provided the firewall is extended to prevent flame and debris from reaching the driver. (Any shape maybe used to form firewall extension.) All firewall inlets shall prohibit passage of flame and debris.

B. Suspension and Running Gear

Suspension is defined as the system of springs, shock absorbers, A-arms, links, etc., supporting the vehicle on its axles. Sway bars, sway bar links, steering rack housings, steering links, etc., are not classified as suspension or running gear for this application.

All components shall be of steel, with the exception of hubs, hub adapters, rear hub carriers, and bearings and bushings. Front hub carrier material shall be of steel or aluminum alloy. The materials for front and rear hub carriers on cars manufactured after January 1, 1983 will be only steel or aluminum alloy. Springs: steel only, titanium is prohibited.

Shock absorbers: Design: Unrestricted.
Casing Material: Steel or aluminum alloy.

All components which are not defined as chassis/frame or suspension or running gear are unrestricted, unless otherwise restricted by the GCR. Titanium is prohibited.

C. Body

1. Definition of Bodywork

Internally: All visible parts of the passenger compartment.

- a. The bodywork opening giving access to the cockpit shall have the following minimal dimensions:
Length: 60cm (23.622 inches)
Width: 45cm (17.72 inches)

This width extends over a length of 30cm (11.811 inches) minimum. This minimal rectangular opening may exist anywhere forward of the firewall. Forward facing roll bar/cage bracing and required padding will not be considered in these dimensions.
 - b. The driver's seat shall be capable of being entered without the manipulation or removal of any part or panel.
 - c. Bodywork, including fuel tanks, shall not exceed a maximum width of 95cm (37.4 inches).
 - d. No part of the bodywork and aerodynamic devices shall exceed the height of a horizontal plane 90cm (35.4 inches) above the ground. The safety roll bar/roll cage and engine air box are not included in this height restriction. Measurements are to be made in any condition, driver on board.
 - e. No part of the bodywork shall extend more than 100cm (39 inches) behind the centerline of the rear axles.
 - f. Any specific part of the car which has an aerodynamic influence on the stability of the vehicle shall be firmly fixed with no provisions for adjustment to vary downforce.
 - g. Sidemounted radiators (behind the front wheels) may extend beyond the 95cm (37.4 inches) limitation, but not beyond a vertical plane passing through the centerlines of the front and rear tires. Any portion of a radiator that extends beyond the 95cm (37.4 inches) limitation cannot be covered with any type of shrouding. Radiators mounted in front of the front wheels are considered front mounted and cannot exceed the 95cm (37.4 inches) limitation.
2. Wings and other airfoil devices which have the principal effect of creating aerodynamic down-thrust are prohibited. Airfoil: Any device or part of a car (excepting normal and conventionally styled bodywork) which has a principal effect of creating aerodynamic downthrust. Within this definition may be included forward facing gaps or openings in the bodywork, but shall not include spoilers in the form of raised surfaces, continuous with the body surface, and not wider than the body surface.
 3. It is the intent of these rules to minimize the use of "ground effects" to achieve aerodynamic down-force on the vehicle. Thus, for the full width of the body between the front and rear axles, the lower surface (surface licked by the air-stream) shall not exceed 2.54cm (1 inch) deviation from the horizontal in any longitudinal section through that surface. (This is not to be interpreted as requiring a floor pan beneath the motor, transaxle, transmission, or final drive housing.) No aerodynamic devices (e.g., skirts, body sides, etc.) may extend more than 1cm (0.394 inches) below the lower surface of the tub or chassis floor to the rear of the front axle. Seat buckets or other protrusions shall not circumvent this rule. It is not permitted to duct air through any part of the bodywork for the purpose of providing aerodynamic downforce on the car. All ducted air for heat exchangers (water/oil) shall pass through those heat exchangers.
 4. Fuel tank air vents shall be located at least 25cm (9.843 inches) to the rear of the cockpit.

Rest of page 26 left intentionally blank

F1600/F2000 Dimensions Table	
Dimension (refer to drawing)	Measurement (cm)
A. Maximum rear wing overhang from rear wheel axis	80
B. Maximum front overhang from front wheel axis	100
C. Maximum wing height measured from the ground with the driver on board	90
D. Exhaust height measured from the ground	20-60 F2000; 10-60 F1600
E. Maximum height of any aerodynamic device forward of the front wheel axis	Rim height
F. Minimum safety rollover bar height inline with driver's spine	92
G. Minimum allowed helmet clearance	5
H. Maximum width- To be taken on the wheel at the axle centerline	185
I. Maximum rear aerofoil width (includes endplates)	95
K. Maximum nose width	135
L. Minimum cockpit opening	45
M. Minimum cockpit parallel opening length	30
N. Minimum cockpit overall opening length	60
R. Maximum body width behind front wheels	95
S. Maximum exhaust length from rear wheel axis	80 F2000; 100 F1600
T. Maximum rear body overhang from rear wheel axis	80 F2000; 100 F1600
7. Minimum wheelbase	200
5. Minimum track	120

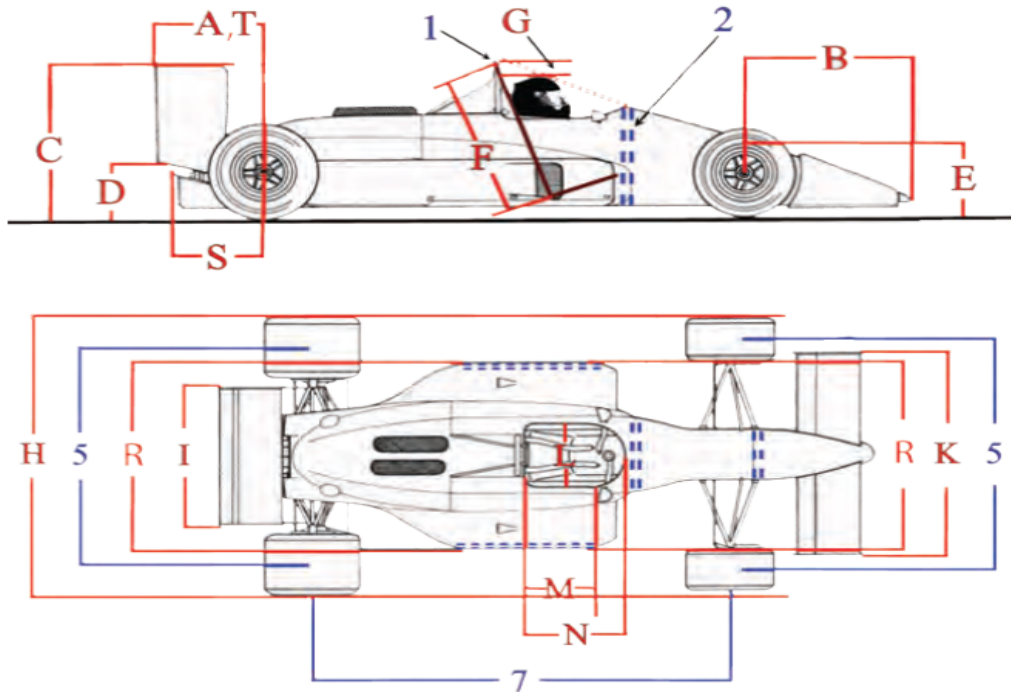

Alternate Vehicle Allowance		
Car	Class	Notes:
Cars complying with English FF rules.	F1600 only	Cars must comply with the English Formula Ford Bodywork and Dimensions Article 3, Cockpit Article 13, Safety Structure Article 15, and Appendix A as published on the Formula Race Promotion's F1600 website (http://www.f1600series.com/pdfs/English%20FF%20Rules-FRP%20applicable.pdf) excepting Wheel width and ground clearance. Allowed Engines: 1600cc Ford Kent or 1500cc Honda per FRP rules. Tires, wheels, transmission, weight and all other items not specifically governed by the aforementioned English rules must comply with current FRP rules.
Stohr 98 FF	F1600 only	Homologation numbers 990089 and 990094 permitted allowance for using chassis tubes for radiator water tubes.

Article 2.2: Mazda MZR F2000 Technical Specifications- 2026

These specifications are part of Formula Race Promotions (FRP) Competition Rules and all automobiles shall conform with these Specifications and FRP Pro Racing Rules (PRR).

F2000 is intended to provide competitors and interested manufacturers with the opportunity to compete in purpose built, highly modified open wheel single seat cars. FRP may alter or adjust specifications and require, permit, or restrict certain specific components to equate competitive potential as deemed necessary.

In an effort to control shock/damper technology and cost to a level reasonable for competitive racing, any fluid dampers are allowed, with the following restrictions:

1. Maximum of 4 dampers/shock absorbers per vehicle.
2. Dampers must be independent from each other with no interconnectivity. However, data acquisition is permissible, as long as it serves no other purpose.
3. Dampers must be manually adjustable only.
4. Mechatronic valves, G valves, hybrid inerters, inerters and mass dampers are prohibited.
5. Electro/Magnetic shock fluid is prohibited.

TECHNICAL SPECIFICATIONS FOR MAZDA MZR POWERED CARS (formally used in USF2000) for COMPETITION in Formula Race Promotion F2000

2.2.1: General

1.1 For avoidance of doubt these rules currently provide for no modification of any component.

1.2 All original Manufacturer identification markings and/or tags must remain as supplied unless otherwise stated in these rules.

1.3 The current Bill of Materials (BOM) will be recognized as the only authorized document which references required specification of parts.

1.4 The 2010+ Elan Motorsports Technologies DP-08 and the 2001-2009 Van Diemen Chassis (with the exception of the 1999 and 2000 chassis that have been updated to 2001 specification) are the only approved chassis.

2.2.2: Reference planes and '0' coordinates

2.1 All measurements shall be taken from the reference plane or '0' coordinates. These shall be established by the chassis Manufacturer and cannot be modified.

2.2 References will be measured using the following coordinates:

- (1) Bottom of the cockpit frame rails.
- (2) Machined surface on the top of the gear box.

2.2.3: Vehicle Dimensions

All dimensions are measured in the listed units and must remain within the following tolerances.

- (1) Front Track – As measured between the wheel centerline – 164 cm
- (2) Rear Track – as measured between wheel centerline- 147 cm
- (3) Wheelbase – 257 cm
- (4) Maximum Total Length – 436 cm
- (5) Maximum Width – as measured at the outer wheel rim – 180cm

2.2.4: Aerodynamic Aids (Formerly Wings & Wickers - Now Conforms with F2000 Section 2.1.5)

- a. A wing shall be defined as any shape that has a leading edge and a trailing edge and creates downforce.
- b. Both front and rear wings/airfoils are a requirement for F2000. (See F1600/F2000 Dimensions Table pg. 27). Cockpit or remote adjustment is not permitted; wings and airfoils shall be non-movable when the car is in operation.
- c. Any part of the car which has an influence on the aerodynamic stability of the vehicle shall be firmly attached with no provisions for adjustment to vary downforce while the car is in motion.
- d. Shaping of the lower surfaces to create "venturi" type tunnels is prohibited. An example of venturi tunnels is shown in the following figure.



- e. It is not permitted to duct air through any part of the bodywork for the purpose of aerodynamic downforce. There shall be no forward facing gaps or openings in or about the bodywork with the exception of those necessary for engine cooling, engine air inlet, shock, or brake cooling. All ducted air for heat exchangers shall pass through those heat exchangers
- f. Primarily vertical air diverters greater than 30 inches forward of the main hoop (i.e. - "bargeboards") that stand away from the cockpit sides and are attached to (or through) the cockpit sides, undertrays and/or sidepods shall be considered as creating forward facing gaps and shall be prohibited.
- g. Wings, endplates and their attachment(s) shall be of metal or glass fiber construction, and may incorporate honeycomb, wood, or foam coring for purposes of maintaining its shape under aero loading. Kevlar reinforcement is permitted.

Rest of page 30 left intentionally blank

2.2.5: Underwing/Underfloor

5.1 The Rear diffuser must be utilized at all Events ~~in the location and configuration determined by the chassis manufacturer. The only approved diffuser is ADP08-40-030.~~
The diffuser must be sourced from Comprent Motorsports to original spec.

5.2 Cars must incorporate a floor, extending from the front bulkhead to the main roll hoop bulkhead with a maximum deviation of 5 mm. Openings are not permitted. This floor must also form the interior floor of the cockpit. Removable heel rests and equipment covers are permitted, subject to approval from the Technical Director. Material is free but must retain the original component silhouette.

5.3 The floor must lie on a single plane. Designs which do not meet the spirit of the "flat bottom" will not be permitted.

5.4 The area of the floor is measured from rearward of the vertical plane tangent to the rear of the front tire and to the fore of the vertical plane tangent to the fore of the rear tires.

5.5 Cars must be fitted with a 4 mm (-1.5 mm Tolerance) thick replaceable jabrock plank (skid) measuring a minimum 30 cm and a maximum 40 cm rearward from the front of the forward bulkhead.

5.6 It is permitted to install a 4 mm (-1.5 tolerance) jabrock panel to the underside of the side pods. The panel may only be one piece per side without holes and cover the entire underside of the side pod. Fasteners must not be less than six inches on center.

5.7 Surface contact (bottoming) blocks on the chassis must be installed with fasteners recessed about the bottom reference plane. Blocks must be non-deformable material and must not produce sparks or cause particles to be directed toward other cars.

5.8 Blocks must be mounted in two planes in the following locations:

1) Maximum of six blocks parallel to the longitudinal centerline of the chassis and not less than 6.0 inches apart. The dimension of each block must not exceed 12.0 inches in length, 1.0 inch wide and 0.5 inches in height from the cars flat bottom.

2) Maximum of three blocks perpendicular to the centerline of the chassis, not exceeding the chassis width at the point of attachment. The dimension of each block must not exceed 2.0 inches in length and 0.25 inches from the cars flat bottom. These blocks may be located in any proximity to the longitudinal blocks.

3) Maximum two blocks permitted on the Rear undertray. The dimension of each block must not exceed 1.0 inch in length, 1.5 inches in width and 0.5 inches in height.

2.2.6: Aerodynamics

6.1 Attachments or devices that are moveable or adjustable while the car is in motion and which may affect airflow are not permitted.

6.2 Maximum wing height measured from the ground with the driver on board is 90cm; Maximum rear aerofoil width (includes endplates) is 95cm.

2.2.7: Bodywork

7.1 Bodywork must be ~~the as-delivered~~ Van Diemen components or equivalent construction, dimension and design, bearing the intact seal as applied by the authorized distributor or approved by the Series.

7.2 Fit and finish is permitted provided it does not alter the components internal or external shape in any way.

7.3 Use of composite materials containing carbon and/or aramids (Kevlar) as reinforcement is prohibited except as permitted herein.

7.4 It is permitted to modify the engine cover in accordance with the description as posted in Competitor Bulletin 11-04.

7.5 It is permitted to fasten or bond the damper cover and dashboard cover into a single component. The fastening of the combined components must be accomplished by using the fastening method of the two individual parts or the addition of two (2) camlocs at the rear of the combined component.

- 7.6 No sprung part of the bodywork is permitted below the plane of the lower surface of the underfloor.
- 7.7 Stress bearing devices, including but not limited to body panels and engine compartment stiffening kits are prohibited.
- 7.8 Van Diemen nosebox crush structure (DP08-40-026) is required, or similar as approved by the SERIES.
- 7.9 Van Diemen side intrusion panels (DP08-40-039/040) **are recommended. Any other cockpit side panels must meet rule 2.1.2.e in these specifications.**
- 7.10 Maximum height of the bodywork is 724 cm, as measured from the bottom of the chassis reference plane.
- 7.11 Maximum Rear overhang including Rear airfoils and endplates is 805 mm, as measured from the Rear wheel axis.
- 7.12 Maximum Front overhang including airfoils and endplates is 955 mm, as measured from the Front wheel axis.
- 7.13 Maximum width of bodywork behind the front wheel is **95 cm.**
- 7.14 Minimum lateral cockpit bodywork opening is 45 cm.
- 7.15 Maximum longitudinal cockpit bodywork opening is 30 cm.
- 7.16 Maximum longitudinal cockpit opening is 83 cm (measured without the head surround).

2.2.8: Bodywork Repairs

- 8.1 All repairs must conform to the Manufacturers original design criteria including weight.
- 8.2 Repairs to other remaining body components not listed above may be performed by Teams or by alternate repair companies provided the original shape and design is maintained.
- ~~8.3 Remanufacturing of any component around the RFID tag is not permitted. Completely re-skinning or manufacturing a new part from a mold is not permitted.~~

2.2.9: Fasteners

- 9.1 All fasteners must be used and remain in the locations as delivered.
- 9.2 Fasteners, washers, nuts, spacers, rod-ends, bearings, spherical bearings, electrical wiring, switches, fittings and hoses are free, provided they are commercially available and the dimensions, grade material and installation remain as originally fitted unless otherwise specified herein.
- 9.3 Cables of alternate source are permitted provided they are of similar specification and weight to the original supplied components and are routed through existing holes.
- 9.4 In all cases titanium and ceramic are prohibited materials.
- 9.5 Replacement bearings must retain the same number of balls as originally manufactured and the outer seals remain in place.

2.2.10: Radiators/Coolers

- 10.1 Only the approved radiators and intercooler as supplied may be used without modification. Water and oil pipes must remain as supplied except for fitment related issues. Bungs for heaters or bleed fittings may be welded to the inlet and outlet pipes. Such items are not permitted on the radiator or components supplied by the engine manufacturer.
- 10.2 Glycol based additives or coolants are prohibited.

2.2.11: Cockpit

11.1 Cockpit regulations are intended for the best interests of the driver's safety, comfort and posture. These must be adhered to in the fullest. Minor changes in the cockpit configuration in order to accommodate driver comfort and operation of the Car controls is permitted with approval from the Technical Director.

11.2 Steering wheels must be fitted with a quick disconnect device. Both the steering wheel and the quick disconnect device are free.

2.2.12: Headrests

12.1 ~~Headrests must be used as supplied (DP08 40 029) and may not be painted, filled or finished with any products except for decals. Headrests must be fitted and used as approved by the SERIES.~~

12.2 All headrests must be inspected and approved by the SERIES before use.

12.3 ~~Headrests must be attached by the chassis Manufacturer supplied mechanism.~~ The headrest must be in place during the technical inspection process and during all on-track activity.

12.4 Additional side padding if used, must not exceed the height of the headrest as viewed from the side. Rear padding must not exceed the height or width of the headrest as viewed from the front. All additional padding must be contained in the headrest dimensions as viewed in plan view.

12.5 Additional padding must be removable independent of each other and without the use of tools. All padding must be manufactured completely of foam although each piece may have a single layer Kevlar backing to assist in the mounting provided that it remains flexible and does not interfere with the original function of the as delivered headrest.

12.6 Any covering used on the additional padding must remain flexible and be approved by the Series. Additional padding may not be taped along any surface. All additional pads and coverings must be inspected and approved by the SERIES before use.

2.2.13: Mirrors

13.1 ~~Mirrors must be used as supplied by the chassis manufacturer. The minimum glass dimension is 6.50 square inches. Mirrors are required, and are free.~~

2.2.14: Electronics

14.1 Any modification to the main wiring harness or the engine control unit (ECU) must be approved in writing by the Technical Director.

14.2 ECU's are under control of Formula Race Promotions (the SERIES), mapped and sealed by the engine supplier. Tampering of ECU's is not permitted.

14.3 Data systems are permitted and must only include the following sensors:

- Engine RPM
- Front Wheel speed (one per side)
- Throttle Position
- Steering Input
- Longitudinal, Lateral and Vertical G-loads
- Water Temperature
- Engine Oil Temperature
- Engine Oil Pressure
- Exhaust Gas Temperature
- Gearbox Oil Pressure
- Gearbox Oil Temperature
- Brake Fluid Pressure
- Fuel Pressure
- Battery Voltage
- Gear Position
- Suspension Travel (4)

14.4 Data systems must have a separate wiring harness with visible wire traceability.

14.5 It is permitted to fit a hydraulic signal damper to the Car to dampen the fuel and oil pressure signals to the data system. The installation must be approved in writing by the Technical Director.

2.2.15: Suspension

15.1 All suspension as provided by the chassis manufacturer must be used within the range of adjustment provided and without modification. **Components must bear the intact approved seal applied by the authorized Van Diemen distributor. Alternate manufacture components must be equivalent to the original Van Diemen design, dimension and construction.**

15.2 Rod ends on suspension and steering components must be retained by either the design of the mounting brackets or by the later area captive washer or by inherent mechanical design of the unit.

15.3 Threaded fittings, as installed, must have a 2X diameter thread engagement inside the suspension component.

15.4 Roll centers and suspension geometry are only adjustable via the rod ends attached to the control arms. Any attempt to alter any pickup location using shims, spacers, washers or any other method is prohibited.

15.5 Suspension bushings (hats, spacers) for dampers, push-rods, anti-roll bars and bell cranks must remain without modification, with the exception of surfacing the outer face for the fitting into each specific location.

15.6 Suspension must not be offset. Track must be equally disposed to the longitudinal centerline of the chassis within a tolerance of +/- .250 inch.

15.7 Ride control – the use of front and rear ride control (example – 3rd springs, dampers) systems are not permitted.

15.8 Anti-Roll Bars and Blades– Only Van Diemen - **or equivalent design** - roll bars with standard drop links permitted. The following are permitted for use:

- Front diameter: 0.625 or 0.875 inches
- Rear Diameter: 0.500 inches

15.9 Rockers – Rockers must be run as supplied by chassis Manufacturer - **or equivalent design** - without modification, except to add nut-plates, and this modification is to add no other purpose.

15.10 Steering – The rack must be used as supplied by the chassis Manufacturer except:

- The rack bar and pinions may be de-burred, shot peened or polished.
- A 0.125" diameter hole may be drilled for purposes of installing an alignment pin.

15.11 Uprights – Uprights must be used as specified by the chassis Manufacturer - **or equivalent design, dimension and construction.**

2.2.16: Brakes and Ducts

16.1 Brake calipers must be either ferrous or aluminum alloy with no more than four pistons per unit. There can be no more than one caliper per wheel.

16.2 Pads are free for MZR powered F2000 cars.

16.3 Brake rotors are restricted to ferrous material

16.4 Master cylinders are a team sourced option.

16.6 Brake fluid is a team sourced option.

2.2.17: Dampers and Springs

In an effort to control shock/damper technology and cost to a level reasonable for competitive racing, any fluid dampers are allowed, with the following restrictions:

- 17.1 Maximum of 4 dampers/shock absorbers per vehicle.
- 17.2 Dampers must be independent from each other with no interconnectivity. However, data acquisition is permissible, as long as it serves no other purpose.
- 17.3 Dampers must be manually adjustable only.
- 17.4 Mechatronic valves, G valves, hybrid inerters, inerters and mass dampers are prohibited.
- 17.5 Electro/Magnetic shock fluid is prohibited.

2.2.18: Driveshafts & Hubs

- 18.1 Only parts provided by the Chassis Manufacturer **or equivalent design, dimension and construction**, are permitted. ~~These must be used as supplied without modification.~~
- 18.2 Driveshafts are free but must be approved in writing by the Technical Director.

2.2.19: Wheels

- 19.1 Material must be metal. The approved sizes are: Front: 13 X 6 inches, Rear: 13X 8 inches.
- 19.2 Positive type wheel-nut locking devices (pins) are required.
- 19.3 Inner wheel covers are **NOT** permitted.

2.2.20: Minimum Weight

- 20.1 Minimum weight for All Events is 1210 pounds.
- 20.2 The minimum weight shall include all fuel, lubricants, coolants and camera, as raced. Driver weight is included.
- 20.3 All ballast must be securely fastened, approved by Officials.

2.2.21: Fuel & Fuel System

- 21.1 The fuel system must remain as supplied by the chassis manufacturer **or equivalent design, dimension and construction**, with the exception of the fuel pump and filter, which are free. **It is recognized that there are a number of safety cell manufacturers that meet FIA and SFI ratings.**
- 21.2 Plumbing of fuel cell lines is free provided the internal hose diameters are not changed.
- 21.3 The maximum capacity of the fuel cell is 7.0 US gallons.

2.2.22: Exhaust

22.1 The exhaust system (~~ECVD1015S~~) must be used without modification as homologated by the engine manufacturer. (~~Elite Engines~~) Internal or external coatings or wraps are permitted.

2.2.23: Clutch Assembly

23.1 Tilton ~~and AP are the only approved clutch suppliers.~~

~~Tilton OT-185 7.25" twin plate clutch assembly~~

~~AP twin plate 7.25" metallic assembly~~

23.2 The clutch master cylinder is a Team sourced item – the manufacturer is not mandated.

2.2.24: Hoses & Fittings

24.1 Hoses, fittings, nuts and bolts may be individually sourced by teams. Hoses may be replaced with hard lines provided the original internal diameter remains in place.

2.2.25: Gearbox and Differential

25.1 Current SCCA GCR permitted gear box and gear sets are permitted as well as the Hewland JL200 5-speed ~~and LD200~~. The Hewland JL200 5 speed gearbox and all internal components are intended to be used as supplied without additions or changes. Rules 25.2 through 25.7 pertain to the Hewland JL200-5 speed gear box. ~~The LD200 cannot have more than 4 forward speeds.~~

25.2 Only seals provided by Hewland are permitted. Low-friction seals are not permitted. *This only applies to the JL200.*

~~25.3 The two (2) adjacent studs of the gearbox differential cover and of the reel selector cover must be drilled to permit fitting of the seals. These holes (maximum 0.050 inch) must be outboard of properly fitted nuts and fit 0.032 inch safety wire. This only applies to the JL200.~~

25.4 Coatings of any kind are not permitted. *This only applies to the JL200.*

25.5 The REM process of gearbox components is permitted. Coatings are not permitted. *This only applies to the JL200.*

25.6 All five (5) speeds must remain in the gearbox during on track activity. Reverse must be operational and the driver must be able to engage it from the cockpit. *This only applies to the JL200.*

25.7 The following ratios may be used in any combination in their designated locations only, unless otherwise specified by Officials: *This only applies to the JL200.*

· 1st: 15-29

· 2nd-5th: 17-27, 18-25, 19-23, 24-26

25.8 Differential – The differential must be unmodified nor influenced in any way to limit or change its normal operation. The only permitted ring and pinion is the 12-34. Only the standard steel differential carrier is permitted.

25.9 Accessories – Filters, screens and magnetic plugs are allowed provided they serve no other purposes.

25.10 Bell Housing – The bell housing must be used as designed and supplied without modification.

25.11 The starter motor as supplied by ~~Elite Engines is the only approved system for use.~~

2.2.26: ENGINE REGULATIONS

26.1 The Mazda MZR 2.0 liter engine as supplied by Elite Engines, Quicksilver Race Engines, or Élan Power must be used without any modification. No variation from specifications regarding installation, oil and filters, fuel, or exhaust are allowed. Teams are to follow the operating manual as provided by the Engine Manufacturer.

26.2 The engines alternator and drive belts must always be connected and in working order. Positive terminals must be insulated.

26.3 Spark Plugs – Mazda p/n 0000-18-L3Y1 or Bosch p/n F 000 KEO P45 7ZB

26.4 Air Box – The air box must not be modified in any way. No material or substance of any kind may be placed / added inside the air box.

The following is permitted:

- (1) The spec Zetek airbox
- (2) Mazda MZR ECVD1021 airbox
- (3) Maximum airbox opening 3.20 X
2.250 inches

26.5 All air entering the Engine must pass through the air filter and restrictor plate before entering the throttle body. *The required restrictor must be mounted directly to the intake manifold.*

26.1.6 ECU – Approved ECUs are the Pectel T2 or the Performance Electronics PE3, using maps as approved by the series. Officials may inspect or replace an ECU or ECU map at any time.

26.1.7 Oil Filter - Oil filter brand, size and type are unrestricted, provided filter can be installed as substitute for the original oil filter without modification. In-line oil filters are permitted.

26.1.8 Catch Tanks - Oil catch tanks must be fitted to the Engine, radiator coolant and transmission breathers venting to atmosphere in such a way as to decrease the likelihood of oil spilling on the Track. Minimum capacity is (1) liter.

26.1.9 RESTRICTOR - The only restrictor allowed is a 1.230”.