

## MICRO SERIE

M10A  
M15A  
M20A  
M25A  
M30A  
M40A

# MICRO SERIE



**FASSI**

LEADER **IN** INNOVATION

## MICRO SERIE

more info>>[www.fassi.com](http://www.fassi.com)

### M10A

LIFTING CLASS:  
Highest moment 1,12 tm / 11 kNm  
MAX OUTREACH:  
up to 2,70 m

### M25A

LIFTING CLASS:  
Highest moment 2,55 tm / 25 kNm  
MAX OUTREACH:  
up to 4,7 m

### M15A

LIFTING CLASS:  
Highest moment 1,53 tm / 15 kNm  
MAX OUTREACH:  
up to 3,0 m

### M30A

LIFTING CLASS:  
Highest moment 3,06 tm / 30 kNm  
MAX OUTREACH:  
up to 4,7 m

### M20A

LIFTING CLASS:  
Highest moment 2,14 tm / 21 kNm  
MAX OUTREACH:  
up to 4,0 m

### FOR ALL MODELS

#### HYDRAULIC EQUIPMENT:

Walvoil monobloc distributor bank  
immediate stop device and pressure gauge

#### CHARACTERISTICS:

rotation with hydraulic motor and pinion  
mechanically limited to 325°.

Crane belonging to the HC1 HD4 S2 class (if installed on truck) according to [EN 12999:2020](https://www.cen.eu/EN/12999-2020)

Images are exclusively for product presentation





SELECT LANGUAGE 



### Features

**BASE** - Cast iron base for ideal stress distribution and greater resistance. The absence of welds provides the crane with characteristics of exceptional duration to fatigue. (1)

**BOOMS GUIDE** - Extension booms guide shoes, with "forced" assembly to reduce vertical and horizontal clearance, ensuring greater durability. Special guide shoes material with high sliding degree and low greasing request.

**PROPORTIONAL DISTRIBUTOR** - Proportional distributor with single side controls. System for D.M. compliance\*

**LIFTING MOMENT LIMITING DEVICE\*** - lifting moment limiting device for automatic load conditions and truck/crane unit stability control with (excluding the M10A) a pressure selector to be activated during the load check procedure of manual extensions: MMC (Micro Manual Control) system for limiting the load of manual extensions (up to a maximum of two) (2).

**LOAD LIMITING DEVICE\*\* (MLC - Micro load control)** - This system, replacing the lifting moment limiter device, is designed to ensure that the maximum load of 995 kg is not exceeded, thereby avoiding the obligation to install the FSC stability system and the MMC device.

### Optional

**TANK** - Plastic tank, particularly resistant to shocks and the corrosive action of any external element. (3)

**WINCH** - Cable-operated lifting device equipped with an exclusive, patented mechanical, torque and end stop limiter system which avoids the risks resulting from direct and indirect overload applied to the winch itself. Anti-revolving cable and cable guide pulley to make easy the aligned winding of the cable on the winch drum.

**ELECTRO-HYDRAULIC CONTROL UNIT** - Electro-hydraulic control unit in protective ABS case. Battery operation available for use on vehicles with no power take off.



### A radio remote control (optional)



#### **SIMPLY**

Easy and compact. 4 linear ergonomic levers. The switch allows to control up to 6 functions.



#### **LINUS 4**

Compact and strong. 4 linear ergonomic levers. The switch allows to control up to 6 functions.



#### **HANDY**

The switch allows to control up to 6 functions. Extremely compact, this is the ideal for a single-hand control. 8 push-buttons allow the proportional control up to 4 functions simultaneously.

\* Compulsory for EU market / \* Compulsory "CE" devices for crane with maximum lifting capacity over kg 995 / \*\* Compulsory "CE" devices for crane with lifting capacity limited to kg 995

**MICRO SERIE**  
Gallery





EN 12999:2020

Crane belonging to the HC1 HD4 S2 class (if installed on truck) according to EN 12999:2020 - Gru appartenente alla classe HC1 HD4 S2 (se allestita su camion) secondo la norma EN 12999:2020 - Grue appartenant à la classe HC1 HD4 S2 (s'il est installé sur le camion) selon la norme EN 12999:2020 - Crane aus der HC1 HD4 S2 Klasse (wenn sie auf Lastwagen montiert) nach EN 12999:2020 - Grúa que pertenece a la clase HC1 HD4 S2 (si está instalado en el camión), de acuerdo con la norma EN 12999:2020 - Kraan die behoren tot de HC1 HD4 S2 klasse (indien geïnstalleerd op de vrachtwagen) volgens EN 12999:2020

OPTIONAL

**MOL**  
Manual  
Outriggers Lock  
**control**

**CPM**  
Crane Position  
Monitoring  
**control**

**MLC**  
Micro Load  
Control  
**control**

**FSC/L**  
Fassi Stability  
Control / Low  
**control**

**MMC**  
Micro Manual  
Control  
**control**

**WL**  
Walvoil  
Distributor Bank  
**control**

**RRC**  
Radio Remote  
Control  
**control**

**MPES**  
Multi Power  
Extension System  
**performance**

**UHSS**  
Ultra High  
Strength Steel  
**strength**

**FWD**  
Fewer Welds  
Design  
**strength**

**CQ**  
Cast Quality  
**strength**

° Compulsory for EU market - Obbligatorio per mercato europeo - Obligatoire pour les marchés de l'UE - Für den europäischen Markt erforderlich - Requerido para el mercado europeo - Vereist voor Europese markt

\* Compulsory for EU market for cranes (M10A excluded) without moment limiting device under 995 kg - Obbligatorio per mercato europeo per gru (esclusa la M10A) senza limitatore di momento sotto i 995kg - Obligatoire pour les marchés de l'UE pour les grues (M10A exclue) sans limiteur de moment en dessous de 995 kg - Für den europäischen Markt (M10A ausgeschlossen) für Krane ohne Momentenbegrenzer unter 995 kg - Requerido para el mercado europeo para las grúas (excluida la M10A) sin limitador de momento por debajo de 995 kg - Verplicht op de Europese markt voor kranen (M10A uitgesloten) zonder momentbegrenzer onder de 995 kg

\*\* Compulsory for EU market for cranes equipped with lifting moment limiting device with a capacity >995 kg - Obbligatorio per mercato europeo per gru dotate di limitatore di momento con portata >995 kg - Obligatoire pour les marchés de l'UE pour les grues équipées de limiteur de moment avec une capacité >995 kg - Für den europäischen Markt (für Krane mit Lastmomentbegrenzung) erforderlich mit einer Tragfähigkeit von >995 kg - Requerido para el mercado europeo para las grúas dotadas de limitador de momento con una capacidad >995 kg - Vereist voor de Europese markt (voor kranen met lastmomentbegrenzing) met een capaciteit >995 kg

**M10A.11**

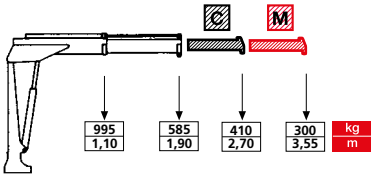

**M10A.12**

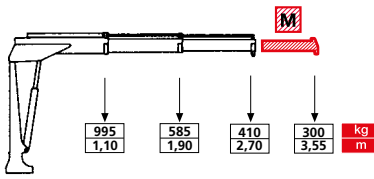

**M15A.11**

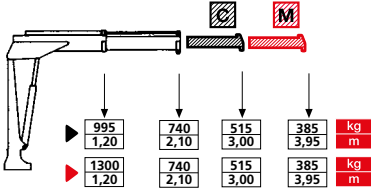

**M15A.12**

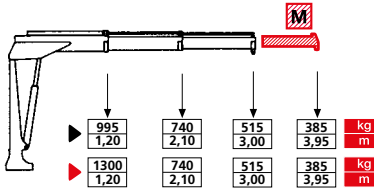

**M20A.11**

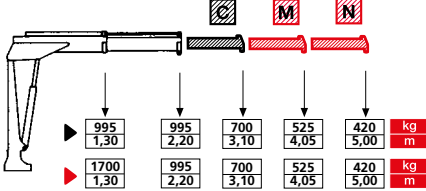

**M20A.12**

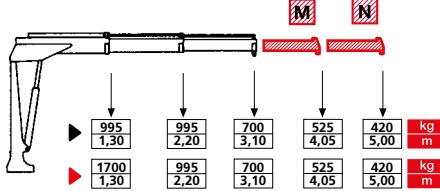

**M20A.13**

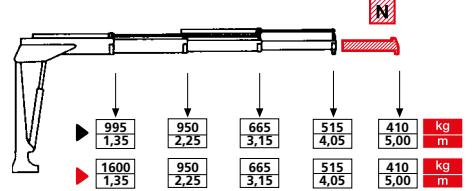

**M25A.11**

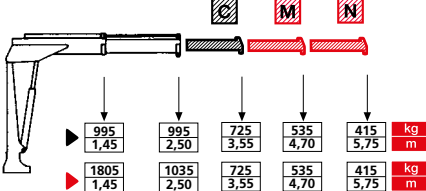

**M25A.12**

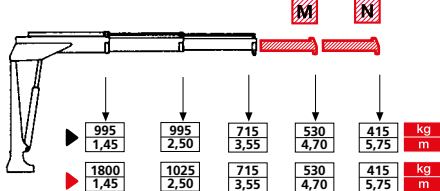

**M25A.13**

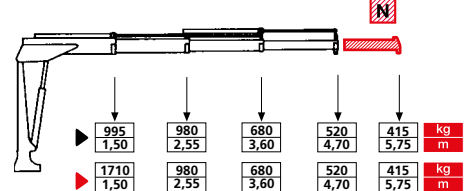

**M30A.11**

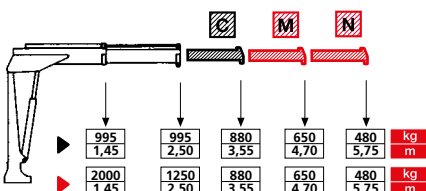

**M30A.12**

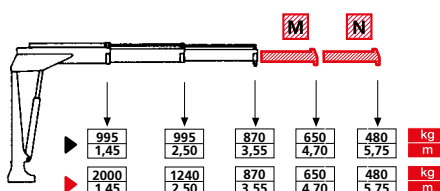

**M30A.13**

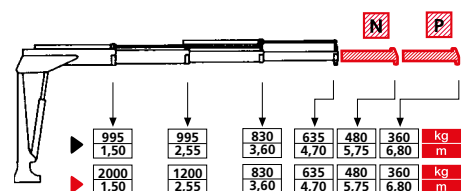

▶ CAPACITY WITH LOAD LIMITING DEVICE (MLC)\*  
PORTATA CON LIMITATORE DI CARICO (MLC)\*  
PORTEE AVEC LIMITER DE CHARGE (MLC)\*  
HUBKRAFT MIT LASTBEGRENZER (MLC)\*  
CAPACIDAD CON LIMITADOR DE CARGA (MLC)\*  
CAPACITEITEN MET BELASTINGBEGRENZER (MLC)\*

▶ CAPACITY WITH LIFTING MOMENT LIMITING DEVICE  
PORTATA CON LIMITATORE DI MOMENTO  
PORTEE AVEC LIMITER DE MOMENT  
HUBKRAFT MIT LASTMOMENTBEGRENZUNG  
CAPACIDAD CON LIMITADOR DE MOMENTO  
CAPACITEITEN MET LASTMOMENTBEVEILIGING

STD M N OPT.

MANUAL EXTENSIONS (CONTROLLED BY MMC SYSTEM) FOR CRANES WITH LIFTING MOMENT LIMITER DEVICE  
PROLLONGHE MECCANICHE (CONTROLLATE DAL SISTEMA MMC) PER GRU CON LIMITATORE DI MOMENTO  
RALLONGES MANUELLES (VERIFIÉ PAR LE SYSTEME MMC) POUR LES GRUES AVEC LIMITATEUR DE MOMENT  
MANUELLE ARMVERLÄNGERUNGEN (VOM MMC-SYSTEM ÜBERPRÜFT) FÜR KRÄNE MIT MOMENTBEGRENZER  
PROLONGAS MANUALES (VERIFICADO POR EL SISTEMA MMC) PARA GRÚAS CON LIMITADOR DE MOMENTO  
MECHANISCHE VERLENGING (GECONTROLEERD DOOR HET MMC-SYSTEEM) VOOR KRANEN MET MOMENTBEGRENZER

\*in place of the lifting moment limiting device - in sostituzione del limitatore di momento - en remplacement du limiteur de moment - anstelle der lastmomentbegrenzung - en sustitución del limitador de momento - ter vervanging van de lastmomentbeveiliging

kg/m																
	kNm	tm	kNm	tm	m	m	°	kNm	MPa	l/min	l	kg	kg	kg	kg	kg
M10A.11	11	1,12	11	1,12	1,9	0,8	325	1,9	18	6	15	145	112	52		
M10A.12	11	1,12	11	1,12	2,7	1,6	325	1,9	18	6	15	155	112	52		
M15A.11	15	1,5	15	1,5	2,1	0,9	325	2,9	18	6	15	190	112	52		
M15A.12	15	1,5	15	1,5	3,0	1,8	325	2,9	18	6	15	200	112	52		
M20A.11	21	2,14	22	2,24	2,2	0,9	325	3,4	18	8	15	195	112	N/A		
M20A.12	21	2,14	22	2,24	3,1	1,8	325	3,4	18	8	15	210	112	N/A		
M20A.13	21	2,14	21	2,14	4,0	2,7	325	3,4	18	8	15	240	112	N/A		
M25A.11	25	2,55	26	2,65	2,5	1,0	325	3,4	15,5	8	15	215	112	N/A		
M25A.12	25	2,55	26	2,65	3,5	2,1	325	3,4	15,5	8	15	230	112	N/A		
M25A.13	25	2,55	25	2,55	4,7	3,2	325	3,4	15,5	8	15	260	112	N/A		
M30A.11	30	3,06	30	3,06	2,5	1,0	325	3,4	18	8	15	215	112	N/A		
M30A.12	30	3,06	30	3,06	3,5	2,1	325	3,4	18	8	15	230	112	N/A		
M30A.13	29	2,96	30	3,06	4,7	3,2	325	3,4	18	8	15	290	112	N/A		

	A	B
Micro M10A	620	1210
Micro M15A	685	1365
Micro M20A.11/12	715	1525
Micro M20A.13	800	1525
Micro M25A.11/12	830	1625
Micro M25A.13	890	1625
Micro M30A.11/12	830	1625
Micro M30A.13	890	1625

	X*	Y*	Z	T	W
<b>S</b>	535	1065	540	1070	140
<b>C</b>	430	630	435	635	140

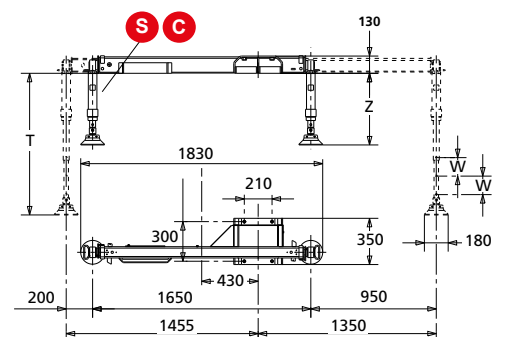
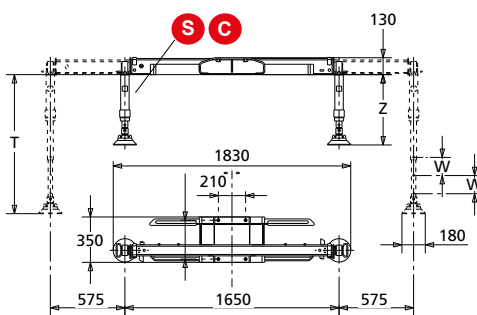
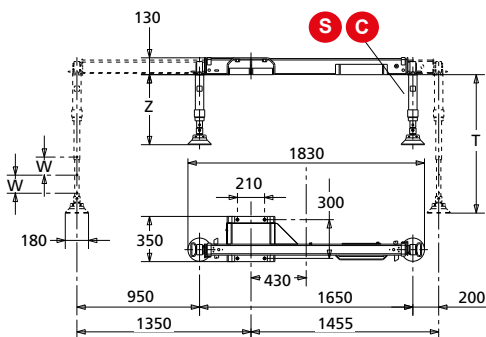
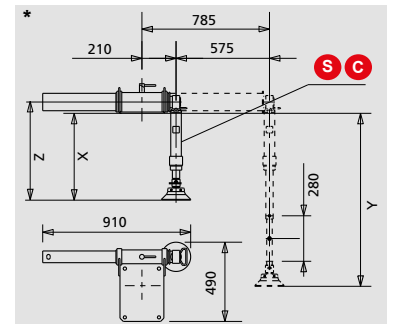
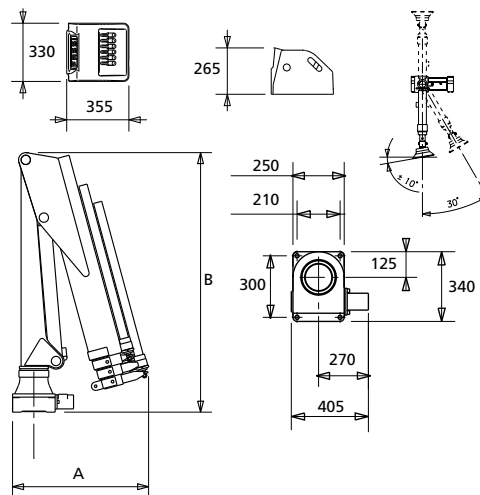

**CERTIFIED**  
**DYNAMIC**  
**PERFORMANCE**

\* AVAILABLE ONLY FOR M10A - M15A  
DISPONIBILE SOLO PER M10A - M15A  
DISPONIBLE UNIQUEMENT POUR M10A - M15A  
VERFÜGBAR NUR FÜR M10A - M15A  
DISPONIBLE SÓLO PARA M10A - M15A  
ALLEN BESCHIKBAAR VOOR M10A - M15A

**S**  
STANDARD

**C**  
SHORT  
CORTO  
KURZ  
KORT

**MICRO SERIE - M40A**  
more info>>[www.fassi.com](http://www.fassi.com)

**M40A.1**

LIFTING CLASS:  
Highest moment 4,00 tm / 39 kNm  
MAX OUTREACH:  
up to 5,85 m

**HYDRAULIC EQUIPMENT:**  
Walvoil monobloc distributor bank  
immediate stop device  
and pressure gauge

**CHARACTERISTICS:**  
with linkage (.1)  
rotation with hydraulic motor and pinion  
mechanically limited to 337°.

Crane belonging to the HC1 HD4 S2 class (if installed on truck) according to [EN 12999:2020](#)

Images are exclusively for product presentation





SELECT LANGUAGE



### Features

BASE - Base in cast steel for perfect stress distribution and greater resistance (1).

BOOMS GUIDE - Extension booms guide shoes, with "forced" assembly to reduce vertical and horizontal clearance, ensuring greater durability. Special guide shoes material with high sliding degree and low greasing request.

EXTENSION RAMS - the location of the extension rams has been optimized in order to reduce the height dimensions, so their feeding is carried out by internal pipes (2).

PROPORTIONAL DISTRIBUTOR - Proportional distributor with single side controls. System for D.M. compliance°

LIFTING MOMENT LIMITING DEVICE\* - lifting moment limiting device for automatic load conditions and truck/crane unit stability control with (excluding the M10A) a pressure selector to be activated during the load check procedure of manual extensions: MMC (Micro Manual Control) system for limiting the load of manual extensions (up to a maximum of two) (3).

LOAD LIMITING DEVICE\*\* (MLC - Micro load control - This system, replacing the lifting moment limiter device, is designed to ensure that the maximum load of 995 kg is not exceeded, thereby avoiding the obligation to install the FSC stability system and the MMC device.

### Optional

TANK - Plastic tank, particularly resistant to shocks and the corrosive action of any external element.

WINCH - Cable-operated lifting device equipped with an exclusive, patented mechanical, torque and end stop limiter system which avoids the risks resulting from direct and indirect overload applied to the winch itself. Anti-revolving cable and cable guide pulley to make easy the aligned winding of the cable on the winch drum.

ELECTRO-HYDRAULIC CONTROL UNIT - Electro-hydraulic control unit in protective ABS case. Battery operation available for use on vehicles with no power take off.

NEW BASE - it allows to invert the installation way meeting thus the installation needs for the vehicles both with left-hand and right-hand drive.



### A radio remote control (optional)



#### SIMPLY

Easy and compact. 4 linear ergonomic levers. The switch allows to control up to 6 functions.



#### LINUS 4

Compact and strong. 4 linear ergonomic levers. The switch allows to control up to 6 functions.



#### HANDY

The switch allows to control up to 6 functions. Extremely compact, this is the ideal for a single-hand control. 8 push-buttons allow the proportional control up to 4 functions simultaneously.

\* Compulsory for EU market / \* Compulsory "CE" devices for crane with maximum lifting capacity over kg 995 / \*\* Compulsory "CE" devices for crane with lifting capacity limited to kg 995



### EN 12999:2020

Crane belonging to the HC1 HD4 S2 class (if installed on truck) according to **EN 12999:2020** - Gru appartenente alla classe HC1 HD4 S2 (se allestita su camion) secondo la norma **EN 12999:2020** - Grue appartenant à la classe HC1 HD4 S2 (s'il est installé sur le camion) selon la norme **EN 12999:2020** - Crane aus der HC1 HD4 S2 Klasse (wenn sie auf Lastwagen montiert) nach **EN 12999:2020** - Grúa que pertenece a la clase HC1 HD4 S2 (si está instalado en el camión), de acuerdo con la norma **EN 12999:2020** - Kraan die behoren tot de HC1 HD4 S2 klasse (indien geïnstalleerd op de vrachtwagen) volgens **EN 12999:2020**

For the **technochips** configuration see page 5 - Per la configurazione **technochips** vedere pag 5 - Pour la configuration des **technochips** voir page 5 - Für die Konfiguration von **Technochips** siehe Seite 5 - Para la configuración de **technochips** ver página 5 - Voor de configuratie van **technochips** zie pagina 5

## Micr40



#### GB LINKAGE SYSTEM

It enables better lifting performance in work areas.

#### IT BIELLISMO

Consente un migliore rendimento prestazionale del sollevamento nelle aree di lavoro.

#### FR SYSTEME DE BIELLE ET FOURCHE

Il permet d'améliorer les performances de levage dans les zones de travail.

#### DE KNIEHEBELSYSTEM

Sie ermöglicht eine bessere Hebeleistung in Arbeitsbereichen.

#### ES MECANISMO A BIELA

Permite un mejor rendimiento de elevación en las zonas de trabajo.

#### NL KNIEHEVELSYSTEEM

Het zorgt voor betere hefprestaties in werkgebieden.

**M40A.1.12**

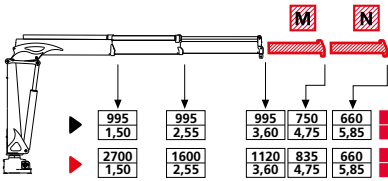

**M40A.1.13**

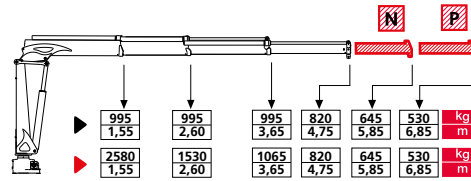

**M40A.1.14**

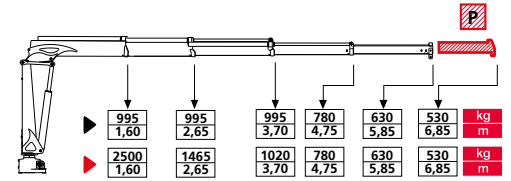

kg/m	▶		▶		▶		▶		▶		▶		
	kNm	tm	kNm	tm	m	m	°	kNm	MPa	l/min	oil	kg	kg
M40A.1.12	35	3,57	40	4,08	3,6	2,1	337	4,2	23	10-15	15	330	190
M40A.1.13	38	3,87	39	3,97	4,7	3,2	337	4,2	23	10-15	15	365	190
M40A.1.14	36	3,67	39	3,97	5,8	4,2	337	4,2	23	10-15	15	400	190

▶ CAPACITY WITH LOAD LIMITING DEVICE (MLC)<sup>°</sup>  
 PORTATA CON LIMITATORE DI CARICO (MLC)<sup>°</sup>  
 PORTEE AVEC LIMITER DE CHARGE (MLC)<sup>°</sup>  
 HUBKRAFT MIT LASTBEGRENZER (MLC)<sup>°</sup>  
 CAPACIDAD CON LIMITADOR DE CARGA (MLC)<sup>°</sup>  
 CAPACITEITEN MET BELASTINGBEGRENZER (MLC)<sup>°</sup>

▶ CAPACITY WITH LIFTING MOMENT LIMITING DEVICE  
 PORTATA CON LIMITATORE DI MOMENTO  
 PORTEE AVEC LIMITER DE MOMENT  
 HUBKRAFT MIT LASTMOMENTBEGRENZER  
 CAPACIDAD CON LIMITADOR DE MOMENTO  
 CAPACITEITEN MET LASTMOMENTBEVEILIGING

▶ OPT.  
 MANUAL EXTENSIONS (CONTROLLED BY MMC SYSTEM) FOR CRANES WITH LIFTING MOMENT LIMITER DEVICE  
 RALLONGHE MECCANICHE (CONTROLLATE DAL SISTEMA MMC) PER GRU CON LIMITATORE DI MOMENTO  
 RALLONGES MANUELLES (VERIFIÉ PAR LE SYSTÈME MMC) POUR LES GRUES AVEC LIMITATEUR DE MOMENT  
 MANUELLE ARMVERLÄNGERUNGEN (VOM MMC-SYSTEM ÜBERPRÜFT) FÜR KRÄNE MIT MOMENTENBEGRENZER  
 PROLONGAS MANUALES (VERIFICADO POR EL SISTEMA MMC) PARA GRÚAS CON LIMITADOR DE MOMENTO  
 MECHANISCHE VERLENGING (GECONTROLEERD DOOR HET MMC-SYSTEEM) VOOR KRANEN MET MOMENTBEGRENZER

\*in place of the lifting moment limiting device - in sostituzione del limitatore di momento - en remplacement du limiteur de moment - anstelle der lastmomentbegrenzung - en sustitución del limitador de momento - ter vervanging van de lastmomentbeveiliging

	A
M40A.1.12	165
M40A.1.13	230
M40A.1.14	285

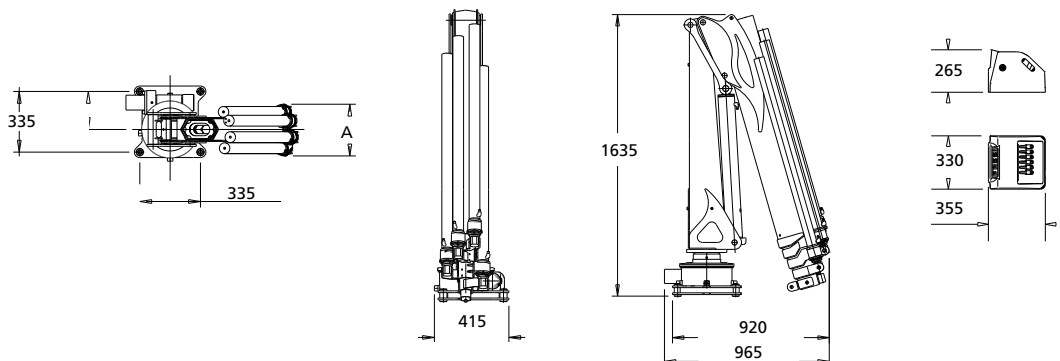

S	C
STANDARD	SHORT
STANDARD	CORTO
STANDARD	COURT
STANDARD	KURZ
STANDARD	CORTO
STANDAARD	KORT

	X	Y	Z
S	525	1055	140
C	420	625	140

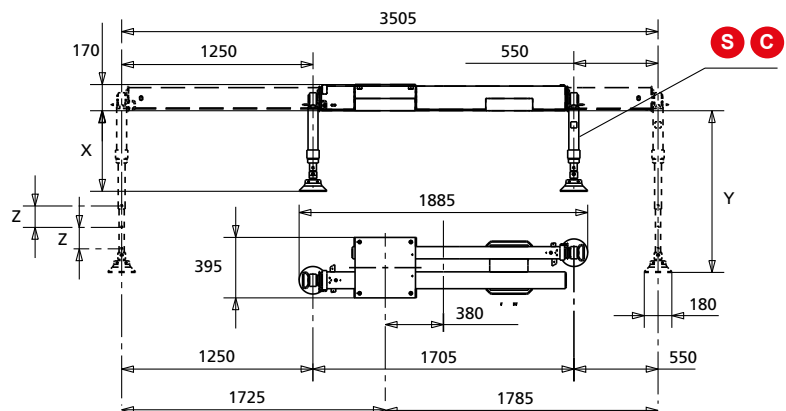
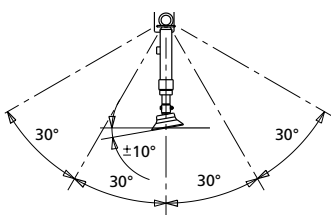

# Lifting Tomorrow



**LEADER IN INNOVATION**



FASSI GRU S.p.A.  
Via Roma, 110  
24021 Albino (Bergamo) ITALY  
Tel- +39 035 776400  
Fax +39 035 755020  
[www.fassi.com](http://www.fassi.com)  
[fassigr@fassigr.com](mailto:fassigr@fassigr.com)

COMPANY WITH  
MANAGEMENT SYSTEM  
CERTIFIED BY DNV GL  
= ISO 9001 =  
= ISO 14001 =