

nienkämper

VOX[®] TABLES

MEGA FLIPTOP



2026

Prices shown are List Prices, FOB our Toronto
Factory- freight charges are extra. Packing and/
or crating is available, if required, upcharges apply.

veneers

All wood surfaces are protected with a durable polyurethane clear lacquer with UV inhibitor. This finish is known for its exceptional durability, as well as abrasion, chemical, impact and scratch resistance. Standard sheen level is 45 degrees. Optional matte, 5, 10 and 35 degree sheen levels are available on request at no additional cost.

Wood Species	Order Code	Veneer/Stain	Upcharge
Maple	F-01	Natural Maple	No upcharge applies.
	F-02	Natural Curly Maple - Rotary Cut	Add 15%.
	F-03	Natural Bird's Eye Maple - Rotary Cut	Call Customer Service for pricing.
	F-04	Maple Stained Pear	No upcharge applies.
Cherry	F-05	Natural Cherry	No upcharge applies.
	F-06	Standard Cherry	No upcharge applies.
	F-07	Cherry Stained Amber	No upcharge applies.
	F-08	Cherry Stained Auburn	No upcharge applies.
	F-09	Cherry Stained Burgundy	No upcharge applies.
Mahogany	F-10	Light Mahogany	No upcharge applies.
	F-11	Medium Mahogany	No upcharge applies.
	F-12	Dark Mahogany	No upcharge applies.
	F-13	Red Mahogany	No upcharge applies.
Anagré	F-14	Natural Figured Anagré - Qtr. Cut Book-Match	Add 15%.
	F-15	Figured Anagré Stained Amber - Qtr. Cut Book-Match	Add 15%.
Sycamore	F-16	Natural Figured Sycamore - Qtr. Cut Book-Match	Add 15%.
Walnut	F-17	Burnt Walnut	No upcharge applies.
	F-19	Natural Walnut- Flat Cut Book-Match	No upcharge applies.
	F-19FM	Natural Walnut- Flat Cut Book-Match (matte sheen)	No upcharge applies.
	F-27F	Creamy Walnut- Flat Cut Book-Match (10° sheen)	No upcharge applies.
	F-27R	Creamy Walnut - Rift Cut Slip-Match (10° sheen)	Add 5%
	F-28	Tawny Walnut	No upcharge applies.
	F-31FM	Autumn Walnut- Flat Cut Book-Match (matte sheen)	No upcharge applies.
	F-31RM	Autumn Walnut - Rift Cut Slip-Match (matte sheen)	Add 5%
Oak	F-18F	Natural White Oak - Flat Cut Book-Match (10° sheen)	No upcharge applies.
	F-18R	Natural White Oak - Rift Cut Slip-Match (10° sheen)	Add 5%
	F-26	Charcoal Ash On Oak- Flat Cut Book- Match (10° sheen)	No upcharge applies.
	F-29F	Smoky Oak - Flat Cut Book-Match	No upcharge applies.
	F-29R	Smoky Oak - Rift Cut Slip-Match	Add 5%
	F-29FM	Smoky Oak - Flat Cut Book-Match (matte sheen)	No upcharge applies.
	F-29RM	Smoky Oak - Rift Cut Slip-Match (matte sheen)	Add 5%
	F-30FM	Whisper White Oak - Flat Cut Book-Match (matte sheen)	No upcharge applies.
	F-30RM	Whisper White Oak - Rift Cut Slip-Match (matte sheen)	Add 5%
	F-32FM	Cotton White Oak - Flat Cut Book-Match (matte sheen)	No upcharge applies.
F-32RM	Cotton White Oak - Rift Cut Slip-Match (matte sheen)	Add 5%	
Sapele – Ribbon Stripe	F-20	Natural Ribbon Strip Sapele - Qtr. Cut Slip-Match	No upcharge applies.
Moabi (Cherry substitute)	F-21	Natural Moabi - Quarter - Qtr. Cut Book-Match	No upcharge applies.
Cape Coast Walnut	F-22	Dark Cape Coast Walnut - Qtr. Cut Slip-Match	No upcharge applies.
	F-23	Natural Cape Coast Walnut - Qtr. Cut Slip-Match	No upcharge applies.
	F-23	Natural Cape Coast Walnut - Qtr. Cut Slip-Match	No upcharge applies.
Ash	F-25	Slate Gray Ash - Qtr. Cut Slip-Match	No upcharge applies.

VENEER GRAIN OPTIONS

Nienkämper products utilize the best quality veneers available, and, combined with Nienkämper's patented veneering systems, create work environments of incredible quality and beauty.

All veneer furniture comes standard with flat cut book-match veneer; flat cut slip-match veneer can also be specified. Quarter cut slip-match and quarter cut book-match veneers are available at a 5% upcharge. Figured Anagré and Figured Sycamore veneers are Quarter cut book-matched. Bird's Eye Maple and Curly Maple are rotary cut. Facet Edge, Taper edge, Flowform, Camber and Self edge tops with veneer are manufactured with a solid wood edge. All edges are then veneer wrapped to create a seamless profile top.

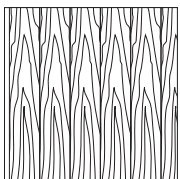

Standard V1
Flat Cut Book-Match

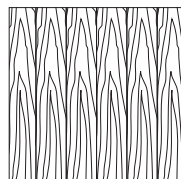

Flat Cut Slip-Match V2

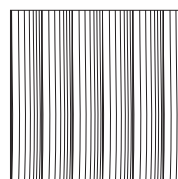

Quarter Cut Slip-Match V3
Add 5%

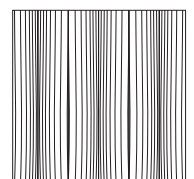

Quarter Cut Book-Match V4
Add 5%

P-LAM

Wood grain plastic laminate surfaces are available on table tops with Facet, Taper and Self edges.

These tops are manufactured with a solid wood edge that is applied prior to the laminate top surface. This method conceals the thickness of the wood edge, while providing the durability required. Wood edges are selected that most closely resemble both the species and the color of the laminate chosen

Nienkämper has pre-selected a number of standard wood grain plastic laminates that represent a cross section of both color and species. Simply include the order code with the model number to make these selections. Alternatively wood grain plastic laminates selected outside of Nienkämper's standard selection can be made by specifying the manufacturer as well as the description and model number of the laminate at the time of order.

Wood Grain Plastic Laminate Surfaces	Order Code	Manufacturer #	Finish
Hardrock Maple	WL2	Pionite WM791-SD	Textured/Suede
Monticello Maple	WL5	Wilsonart 7925-38	Fine Velvet Texture
Fusion Maple	WL13	Wilsonart 7909-60	Matte
New Age Oak	WL14	Wilsonart 7938-38	Fine Velvet Texture
Wild Cherry	WL18	Wilsonart 7054-60	Matte
River Cherry	WL19	Wilsonart 7937-38	Fine Velvet Texture
Montana Walnut	WL20	Wilsonart 7110T-78	Fine Grain
Skyline Walnut	WL26	Wilsonart 7964K-12	Soft Grain
Continental Walnut	WL-29	Wilsonart 8232K-05	Timbergrain
Neo Walnut	WL-30	Wilsonart 7991-38	Fine Velvet Texture
Walnut Heights	WL-31	Wilsonart 7965K-12	Soft Grain
Grayed Oak	WL-32	Formica 5791-PG	Pure Grain Texture
Millennium Oak	WL-33	Formica 5887-58	Matte
Aged Ash	WL-34	Formica 8844-WR	Woodbrush
Lowell Ash	WL-35	Wilsonart 7994-38	Fine Velvet Texture
Natural Ash	WL-36	Formica 8843-WR	Woodbrush
Norwegian Ash	WL-37	Wilsonart 8241-38	Fine Velvet Texture
Weathered Ash	WL-38	Formica 8842-WR	Woodbrush
Smoky Brown Pear	WL-39	Formica 5488-26	Oiled Wood
Studio Teak	WL-40	Wilsonart 7960K-18	Linearity
Fawn Cypress	WL-41	Wilsonart 8208K-16	Casual Rustic
Landmark Wood	WL-42	Wilsonart 7981K-12	Soft Grain
Natural Cerise	WL-43	Formica 8863-58	Matte
Natural Recon	WL-44	Wilsonart 7996-38	Fine Velvet Texture
Pecan Woodline	WL-45	Formica 5883-58	Matte

To specify the wood grain laminate required simply add the Order Code WL_ to the model number of the product.

Samples and specific technical data is available from your local sales representative or by contacting Nienkämper's Customer Service department at **800.668.9318**.

P-LAM

COLORED P-LAM

Both Taper and Self edge profiles are available with a colored laminate top.

Laminate edging on Taper tops. Edging will match the top surface and is applied before the surface laminate. By applying the laminate in this way, the seam is positioned horizontally, which makes it much less conspicuous and more durable.

Wood edging on Self and Taper Edge tops are applied before the laminate. By applying the wood edge in this way, the wood edge thickness is concealed, while providing the durability required. Wood species and finishes for edging can be selected from page 8.

For laminates specified outside of Nienkämper's standard selection, specify the manufacturer as well as the description and model number of the laminate selected at the time of order. For Facet edge tops, the laminate must be a post-forming grade.

Translucent edging on Self and Taper edge tops is applied after the surface laminate. The translucent edge is very durable. Clear translucent edge provides a good match with most white-colored laminates, while a silver translucent edge provides a metallic look and contrast to colored plastic laminates.

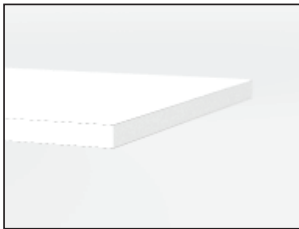

P-Lam top & Self edge

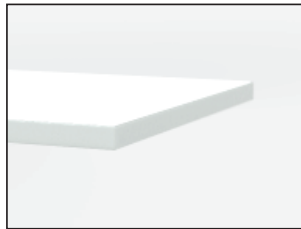

P-Lam top & Translucent Self edge



Wood Grain P-Lam top & silver Translucent Self edge

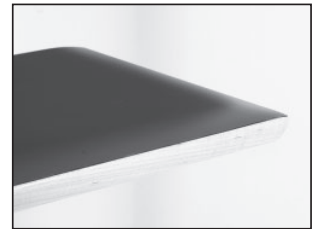

P-Lam top & solid wood Facet edge

*An unavoidable, thin dark line will be visible when specifying a matching p.lam edge. This is more pronounced with light colored laminates

Colored Plastic Laminates Surface	Order Code	Manufacturer #	Finish
Gray (Nienkämper - Light Gray/Putty)	CL-01	Wilsonart 1500-60	Matte
Platinum Gray (Nienkämper - Medium Gray/Clay)	CL-02	Nevamar S6023T	Textured
Slate Grey (Nienkämper - Dark Gray)	CL-03	Wilsonart D91-60	Matte
Black	CL-04	Wilsonart 1595-60	Matte
Angel White	CL-05	Pionite SW-826SD	Textured/ Suede
Frosty White	CL-06	Wilsonart 1573-60	Matte
White (for writable surface)	Contact customer service for details 800.668.9318		Gloss

Add the order code behind the edge profile when specifying.

P-LAM

FINGERPRINT RESISTANT P-LAM

Fingerprint Resistant Plastic Laminate is an innovative material created for interior design applications and is suitable for both vertical and horizontal interior applications on our Nienkämper furniture.

The external surface of Fingerprint Resistant Plastic Laminate involves the use of nanotechnology made possible by next generation acrylic resins.

The unique composition offers extraordinary features coupled with a unique user experience. These include an ultra matte surface (eliminating glare), an ultra soft feel, an anti-fingerprint surface, thermal healing of micro-scratches, increased durability as well as anti-bacterial and mold-resistant properties.

Edgeband matching all Fingerprint Resistant Plastic Laminate colors is only available when specifying a Taper edge. For Self edge tops 1" and 1 1/4" thick, matching edgeband are only available in Black (RL-01) and White (RL-03). When a matching edgeband is not available, the specified surface laminate is used on the edge. **Contact Customer Service for more details 800.668-9318.**

There is a 20% upcharge on our standard plastic laminate table pricing for Fingerprint Resistant Plastic Laminate.

Colored "Fingerprint Resistant" Plastic Laminate Surface	Order Code	Finish
Black	RL-01	Matte
Gray	RL-02	Matte
White	RL-03	Matte
Sand	RL-04	Matte
Brown	RL-05	Matte
Clay	RL-06	Matte
Beige	RL-07	Matte
Ash	RL-08	Matte
Smoke	RL-09	Matte

Edgeband to Match with Colored "Fingerprint Resistant" Plastic Laminate	Thickness	Order Code
Black	3/4", 1", 1-1/4"	RE-01
Gray	3/4"	RE-02
White	3/4", 1", 1-1/4"	RE-03
Sand	3/4"	RE-04
Brown	3/4"	RE-05
Clay	3/4"	RE-06
Beige	3/4"	RE-07
Ash	3/4"	RE-08
Smoke	3/4"	RE-09

ALUMINUM/PAINT FINISHES - VOX®

ALUMINUM FINISHES

Anodized Aluminum Finishes	Order Code
Silver	AL-01
Champagne	AL-02
Light Bronze	AL-03
Bronze	AL-04
Black	AL-06

Simply specify the finish of choice when placing your order. Note upcharges may apply for non-standard finishes. Anodized aluminum and paint finish samples are available from your local sales representative or by calling Nienkämper's Customer Service department, at **800.668.9318**.

PAINT FINISHES

Some Vox® components are painted.

Paint finishes are generally used when anodizing is not an option, (i.e. castings). While color matching is close, it is impossible to match exactly the qualities of anodizing with paint finishes.

Standard Paint	Order Code
Silver	SP-01
Champagne	SP-02
Light Bronze	SP-03
Angel White	SP-04
Frosty White	SP-05
Black	SP-06

Metallic Paint	Order Code
Silver Metallic	MP-01
Champagne Metallic	MP-02
Light Bronze Metallic	MP-03

Powder Coat Paint	Order Code
Nienkämper Silver	PC-01
Champagne	PC-02
Light Bronze	PC-03
Standard Bronze	PC-04
Black Jack	PC-06
Warm White	PC-07
Red	PC-09
Cool White	PC-12
Pure Orange	PC-14
Lime	PC-16
Sky Blue	PC-17
Cobalt Blue	PC-18
Charcoal Gray (Matte)	PC-22
Matte Red Clay	PC-24
Cream	PC-25
Mulberry	PC-26
Forest Green (Matte)	PC-27
Mustard (Matte)	PC-28

VOX® MEGA FLIP TOP TABLES

Looking for a flip top table with a larger top? The Vox® Mega FlipTop™ table provides you a solution. It is easy to move and reconfigure. The tables are ganged together to create an almost seamless conference table.



To configure a boardroom table 240"L x 60"D, you need only 4 Vox® Mega FlipTop™ tables of 60"L x 60"D.

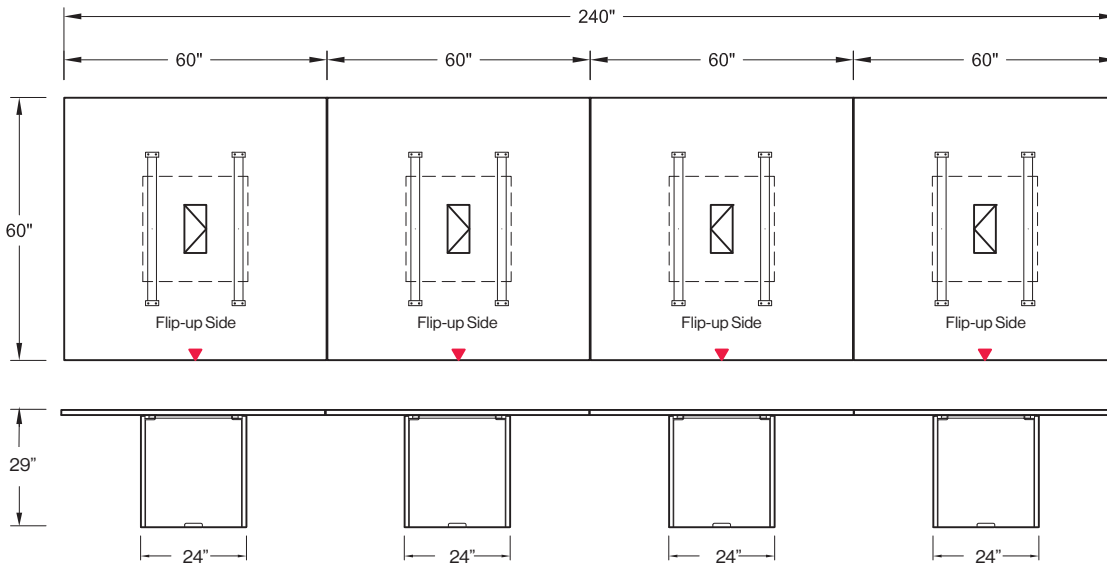

Top & Base Finishes

All standard Nienkämper veneers, stains and laminates.

Edge Details



1/4" thick Self Edge (SE)

VOX® MEGA FLIP TOP TABLES

Base

Vox® Mega FlipTop table is supported by a tapered base which is standard in dimension 24"W x 24"D for all sizes of top. There is a removable panel on the base for easy access of cables inside.



Surface Shapes & Sizes

Top is 1 1/4" thick and overall height is 29"H.
Length: 48", 54" & 60"; Depth: 54" & 60"

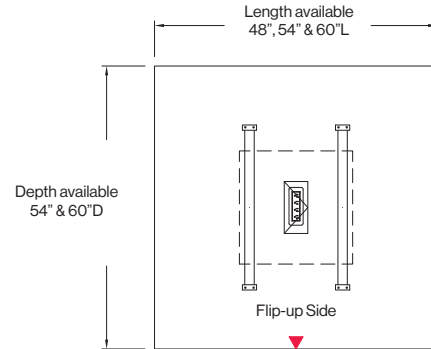

Elevation

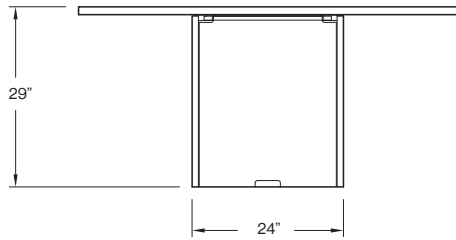

Front elevation showing removable panel of the base

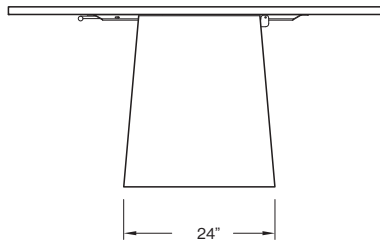

Side elevation showing fixed panel of the base

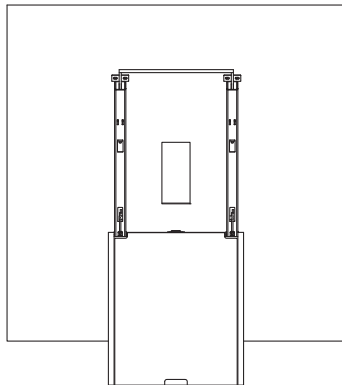

Front elevation showing table top flipped up

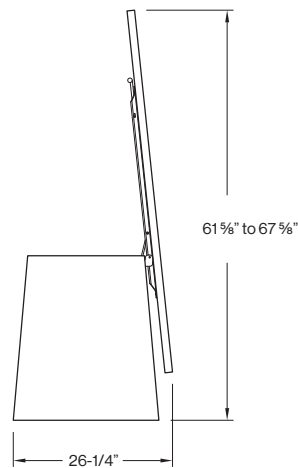

Side elevation showing table top flipped up

The 60"W x 60"D Vox® Mega FlipTop™ table has a width of only 27"W when flipped up and will fit through door ways.

Overall height of the table when it is flipped up is 61 5/8"H for 54"D top.

VOX® MEGA FLIP TOP TABLES

Wiring & Connectivity

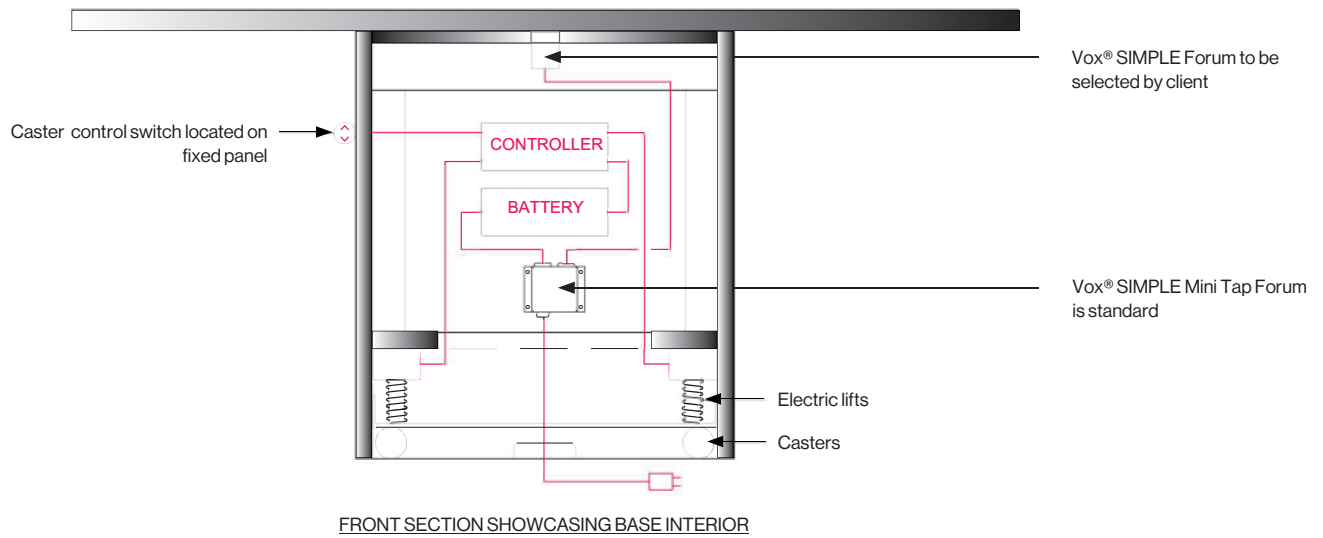

All Vox® Mega FlipTop™ tables come equipped with a Vox® SIMPLE Mini Tap Forum, mounted discreetly within the table base. This unit includes two pre-wired receptacles that supply power to the rechargeable battery for the caster-lifting mechanism, as well as to the optional Vox® SIMPLE Forum located at the top of the base.

An optional, 6 port, Vox®SIMPLE Forum of your choice can be installed on top of the base. This Forum can be easily accessed from a hinged grommet when the table top is flipped down. Refer to pages 204- 206 for Forum selections.

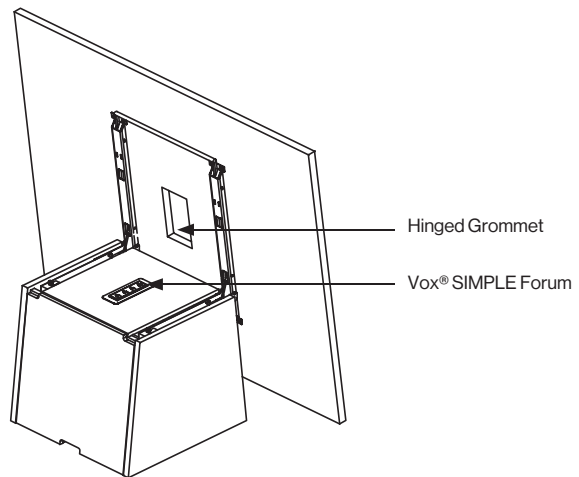

Vox® Mega FlipTop™ tables ordered with Vox® SIMPLE Forums also require an additional rectangular, hinged top grommet. Add choice below when ordering.

Model Number	Dimension	Finish	List Price
70840	11" w x 5" d	Silver Anodized Aluminum	565
70841	11" w x 5" d	Black Anodized Aluminum	565

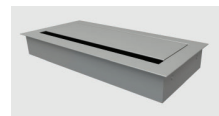

VOX® MEGA FLIP TOP TABLES

How to reconfigure the Vox® Mega FlipTop™ Table:

Five easy steps:

1. Unlatch the table's integrated ganging mechanism, which is permanently attached to the table and requires no tools to release.



2. To flip up the top, pull the handle on the underside toward yourself to release the latch. The gas cylinders in the base allow the top to be lifted with one hand.

3. Press the "Up" button on the side panel to raise the four swivel casters, allowing you to easily move the table.



4. Once the table is in position, press the "Down" button to lower the swivel casters, allowing the base to sit flush on the floor.



5. Finally, push the top down until you hear a click, confirming that it is locked in the down position. Then gang the tables together using the integrated ganging mechanism.

Note: The electrically operated casters are powered by a lifting mechanism connected to a battery box. Both components can be stored within the base. Once fully charged, the battery supports up to 100 lift cycles.

VOX® MEGA FLIP TOP TABLES

1¼" thick top, overall height 29"H. Base dimension: 24"W x 24"D



Self Edge (SE)

L"	X	D"	Sugg Seat Capacity	Top Finish	Top Sections	Model Number	List Price
48	54	6	6	Veneer	1	56451/2	16,340
48	54	6	6	Laminate	1	56451/5	15,245
54	54	8	8	Veneer	1	56452/2	17,090
54	54	8	8	Laminate	1	56452/5	15,825
60	54	8	8	Veneer	1	56453/2	17,670
60	54	8	8	Laminate	1	56453/5	16,250
48	60	6	6	Veneer	1	56461/2	16,820
48	60	6	6	Laminate	1	56461/5	15,610
54	60	8	8	Veneer	1	56462/2	17,670
54	60	8	8	Laminate	1	56462/5	16,250
60	60	8	8	Veneer	1	56463/2	18,660
60	60	8	8	Laminate	1	56463/5	16,990

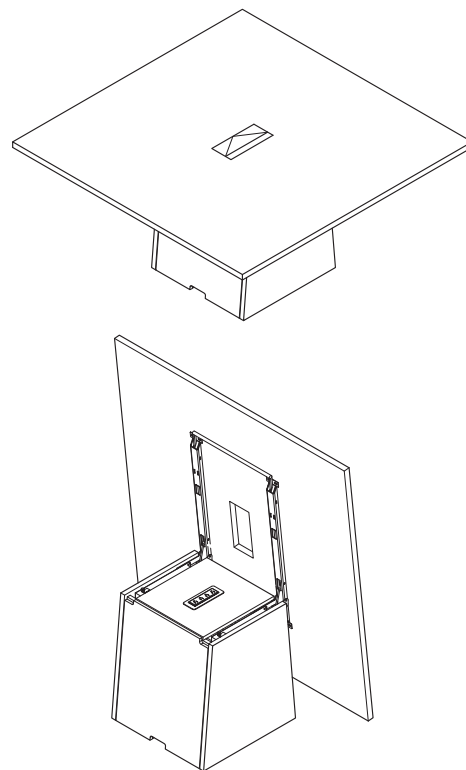

Vox® Mega FlipTop™ Table in walnut veneer with Trench medium back chairs and upholstered arms.

FORUMS - SIMPLE FORUM

SIMPLE FORUM – SINGLE SIDED (SURFACE MOUNTED)

List Price

Pre-configured SIMPLE Forum (6 ports 9³/₄" L x 2" W)

Model # 39941/6	pre-wired power	<table border="1"> <tr> <td>1P</td> <td>1P</td> <td>A5</td> <td>A5</td> <td>B</td> <td>B</td> </tr> </table> <p>2 x pre-wired power with 10ft cord 2 x SIEMON CAT6 data with 10ft cord 2 x blank plate</p>	1P	1P	A5	A5	B	B	\$810
1P	1P	A5	A5	B	B				
Model # 39942/6	site-wired power	<table border="1"> <tr> <td>1P-SW</td> <td>1P-SW</td> <td>A5</td> <td>A5</td> <td>B</td> <td>B</td> </tr> </table> <p>2 x site-wired power with 6ft metallic shielded cable 2 x SIEMON CAT6 data with 10ft cord 2 x blank plate</p>	1P-SW	1P-SW	A5	A5	B	B	\$880
1P-SW	1P-SW	A5	A5	B	B				
Model # 39943/6	pre-wired power	<table border="1"> <tr> <td>1P</td> <td>1P</td> <td>A5</td> <td>A5</td> <td>G</td> <td>C</td> </tr> </table> <p>2 x pre-wired power with 10ft cord 2 x SIEMON CAT6 data with 10ft cord 1 x HD-DB15/VGA connector with 10ft cord 1 x audio 3.5mm mini stereo jack with 10 ft cord</p>	1P	1P	A5	A5	G	C	\$985
1P	1P	A5	A5	G	C				
Model # 39944/6	site-wired power	<table border="1"> <tr> <td>1P-SW</td> <td>1P-SW</td> <td>A5</td> <td>A5</td> <td>G</td> <td>C</td> </tr> </table> <p>2 x site-wired power with 6ft metallic shielded cable 2 x SIEMON CAT6 data with 10ft cord 1 x HD-DB15/VGA connector with 10ft cord 1 x audio 3.5mm mini stereo jack with 10ft cord</p>	1P-SW	1P-SW	A5	A5	G	C	\$1,060
1P-SW	1P-SW	A5	A5	G	C				
Model # 39945/6	pre-wired power	<table border="1"> <tr> <td>1P</td> <td>1P</td> <td>A5</td> <td>A5</td> <td>HD</td> <td>H</td> </tr> </table> <p>2 x pre-wired power with 10ft cord 2 x SIEMON CAT6 data with 10ft cord 1 x HDMI coupler with 18" cord 1 x USB port 3.0 with 10ft cord</p>	1P	1P	A5	A5	HD	H	\$1,010
1P	1P	A5	A5	HD	H				
Model # 39946/6	site-wired power	<table border="1"> <tr> <td>1P-SW</td> <td>1P-SW</td> <td>A5</td> <td>A5</td> <td>HD</td> <td>H</td> </tr> </table> <p>2 x site-wired power with 6ft metallic shielded cable 2 x SIEMON CAT6 data with 10ft cord; 1 x HDMI coupler with 18" cord 1 x USB port 3.0 with 10ft cord</p>	1P-SW	1P-SW	A5	A5	HD	H	\$1,080
1P-SW	1P-SW	A5	A5	HD	H				
Model # 39947/6	pre-wired power	<table border="1"> <tr> <td>1P</td> <td>1P</td> <td>1P</td> <td>A5</td> <td>A5</td> <td>A5</td> </tr> </table> <p>3 x pre-wired power with 10ft cord 3 x SIEMON CAT6 data with 10ft cord</p>	1P	1P	1P	A5	A5	A5	\$965
1P	1P	1P	A5	A5	A5				
Model # 39948/6	site-wired power	<table border="1"> <tr> <td>1P-SW</td> <td>1P-SW</td> <td>1P-SW</td> <td>A5</td> <td>A5</td> <td>A5</td> </tr> </table> <p>3 x site-wired power with 6ft metallic shielded cable 3 x SIEMON CAT6 data with 10ft cord</p>	1P-SW	1P-SW	1P-SW	A5	A5	A5	\$1,025
1P-SW	1P-SW	1P-SW	A5	A5	A5				

FORUMS - SIMPLE FORUM

SIMPLE FORUM – SINGLE SIDED (SURFACE MOUNTED)

List Price

Pre-configured SIMPLE Forum (6 ports, for client’s own data fitting)

Model # 39951 pre-wired power

1P	1P	O	O	O	O
----	----	---	---	---	---

 \$595

2 x pre-wired power with 10ft cord
4 x open port/data adapter to fit in client’s own data fitting and cord

Model # 39953 pre-wired power

1P	1P	1P	O	O	O
----	----	----	---	---	---

 \$615

3 x pre-wired power with 10ft cord
3 x open port/data adapter to fit in client’s own data fitting and cord

Adapter “AA”

Systimax/CommScope
Uniprise/CommScope

Adapter “BB”

L-Com Keystone Modular
Tyco SL/110 Connect Series Modular Jacks
Siemon Keystone Style
Allen Tel Versa Tap Series
Leviton Quick Port® Series
Nordx Keystone Style
Tyco SL Conpler Series

Adapter “CC”

Krone 6000 Series/ADC
Hubbell Xcelerator™ Keystone Series

Adapter “DD”

blank

Adapter “EE”

Ortronics TracJack Series

Adapter “FF”

Panduit Mini-Com Series

Adapter “GG”

microphone jack / 3pin XLR, solder type only

Adapter “HH”

Adapter “HH” - video monitor jack / DB-15, panel mount solder type.

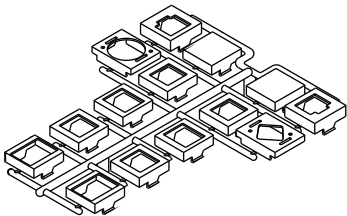

• Snap in fitting adapters are also provide for 3-pin XLR microphone jack (solder type only) and DB-15 video monitor jack (panel mount solder style only)

VOX® MEGA FLIPTOP

SIMPLE FORUM

Configure your own Vox® SIMPLE Forum by selecting a base model and required elements.

CUSTOM SIMPLE FORUM















CX6- _____

LIST PRICE

\$375

Select the elements as per below:

		LIST PRICE
	S-1P - 1 power receptacle with 10' white cord	\$145
	S-1P-SW - 1 power receptacle hard wired with a 6' whip	\$165
	A5 - SIEMON CAT 6 data fitting with 10' connector cable	\$180
	C - Audio- 3.5mm Mini stereo Jack with 10' cord	\$90
	H - USB port 3.0 with 10ft cord	\$135
	2U - Stacked USB charger A+C	\$170
	3U - Dual USB C charger	\$170
	G - DB15HD, VGA connector, 10' cord	\$195
	HD - HDMI Coupler with 18" cord	\$195
	B - Blank plate	\$65
	O - Open port, for client's own data fitting. Each port selected will be supplied with one set of data adapter kit	\$65
	L - Belay 1" dia. hole opening rubber strain relief pass through cords	\$65

TERMS AND CONDITIONS OF SALE

PRICES

All prices are list prices, FOB our Toronto Factory- freight charges are extra. Packing and/ or crating is available, if required, upcharges apply.

Due to existing conditions in regard to cost of labor and materials, we reserve the right to change prices without notice.

TERMS

Net 30 days from date of invoice to accredited buyers. Two per cent (2%) interest charged monthly on overdue accounts. Deposit of 50% is required with order. Terms will be established upon credit evaluation. Due to delays in processing references, first orders may be treated as C.B.D. orders.

ORDER CONFIRMATION

Orders are accepted upon issuance of our order confirmation and are subject to the terms set forth therein; notwithstanding any variance from the terms of the buyer's order form.

Nienkämper is not liable for any delay or failure to deliver caused by labor or transportation difficulties, accidents, acts of God, failure of sources of supply, or other causes beyond our control, and changes will affect the delivery date.

CHANGE OF ORDERS OR CANCELLATIONS

Changes or cancellations are subject to our ability to conform. A charge will be levied against canceled or changed orders based on costs already incurred by Nienkämper. All changes must be in writing and submitted on a revised purchase order. Changes will affect the delivery date.

STORAGE

If goods cannot be accepted when ready, we may transfer them to storage (which is to be deemed as delivery for invoice purposes). The customer accepts risks and will be charged at prevailing rates.

FREIGHT

All prices are list prices, FOB our Toronto Factory- freight charges are extra.

Packing and/or crating are available, if required, upcharges apply.

CLAIMS

All furniture is given to the carrier and signed for in good condition. It is the responsibility of the receiver to sign for the goods in the presence of the carrier and note the condition in which they are received. Freight claims should be filed with the carrier.

WARRANTY

There are no express or implied warranties, conditions and obligations of the manufacturer, whether statutory or otherwise that extend beyond the description on the face hereof. Our furniture is made to the highest standard and is warranted free from defects of material and workmanship for five years from the date of delivery. During the warranty period we will repair or replace such merchandise as shall prove to be defective, during normal usage in accordance with manufacturer's specifications. The manufacturer shall not be liable for defect wholly attributable to normal manufacturing process. Replacement or repair of the Product shall be the sole remedy of the Customer, and the manufacturer shall not be liable for any direct, indirect, incidental, or consequential loss or damage suffered by the Customer by reason of any defect in workmanship or manufacture of the Product or inability to use the Product. Moreover, this warranty does not cover accidental damage, abuse, alteration, ordinary wear and tear of Goods, negligence and misuse nor variations over which we have no control such as heat or humidity or damage to which the Goods are connected that is not attributable to the failure of the goods themselves. This warranty is null and void when the product is installed with hardware other than that supplied and/or when installed differently than recommended in the installation guide. Modification to the product or hardware may result in failure of the product and cause damage and/or injury.

WOOD FINISHES

Nienkämper offers a wide variety of standard light finishes on cherry, mahogany and figured anagre wood veneers, and a clear natural finish on figured anagre, figured sycamore, maple, bird's eye maple and curly maple.

Light finishes do not mask the grain and other characteristics of each wood species. It is important to understand that pieces of the same type of wood will not look identical when a light finish is used. The appearance of the finish will also depend on the natural color of the veneer. Cherry darkens over time as the wood ages. Pin knots and gum pockets are inherent traits.

Wood is a naturally variable raw material; its variances are not within the furniture manufacturer's control and are therefore not considered defects under this warranty.