

# Pleat™ Collection Private Office Installation

## COMPLETED ASSEMBLY









## WHAT YOU WILL NEED

### TOOLS REQUIRED

- Drill / Driver
- Level
- Tape Measure
- Allen Keys
- Stud Finder
- Screwdriver
- Ladder / Step Stool

### HARDWARE

-  Wall Cleat
-  1/4\"-20 x 1 1/2\" Joiner Bolt
-  1/4\"-20 x 1 1/4\" Joiner Bolt
-  1/4\"-20 x 7/8\" Joiner Bolt
-  1/4\"-20 x 9/16\" Joiner Bolt
-  #6 x 5/8\" Pan Hd Screw

### BEFORE YOU BEGIN

- Verify components before assembly
- Confirm wall structure is suitable for anchoring.
- Protect finished surfaces.
- Two Installers recommended.
- Estimated Assembly Time 2-3 Hours

## 01 INSTALL WALL CLEATS

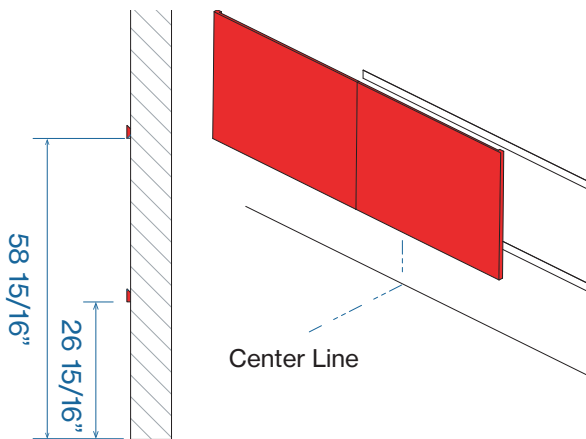

- Locate workstation center line.
- Level and fasten wall cleats per dimensions shown.
- Slide tack panels onto cleats.

## 02 INSTALL SHELF & LIGHTING

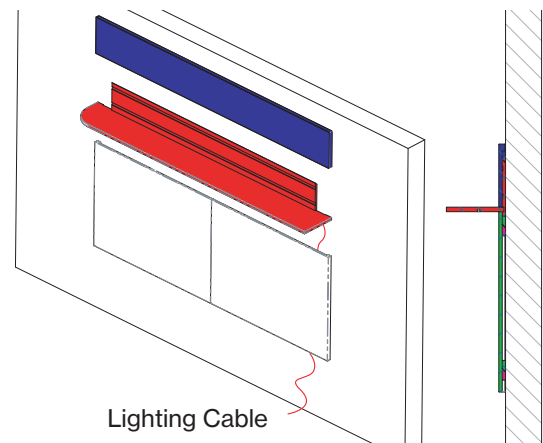

- Lower shelf cleat behind tack panel until seated.
- Fasten cleat to wall.
- Install trim panel onto cleat.
- Route light power cable behind right tack panel.

## 03 INSTALL CLOSET & PEDESTAL

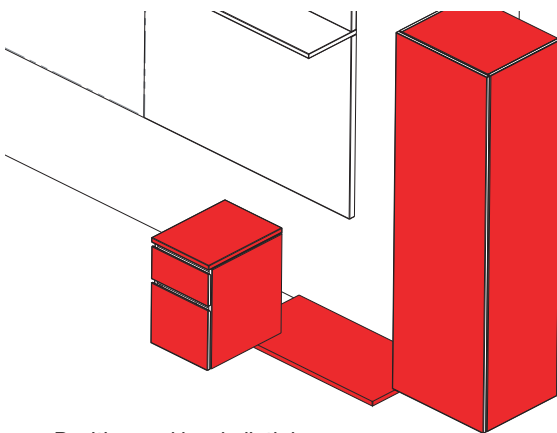

- Position and level plinth base.
- Place closet and pedestal onto base.
- Ensure closet power cable remains accessible on left side.
- Secure units together using: 1/4\"-20 x 1 1/4\" joiner bolts

## 04 INSTALL HEIGHT ADJUSTABLE DESK

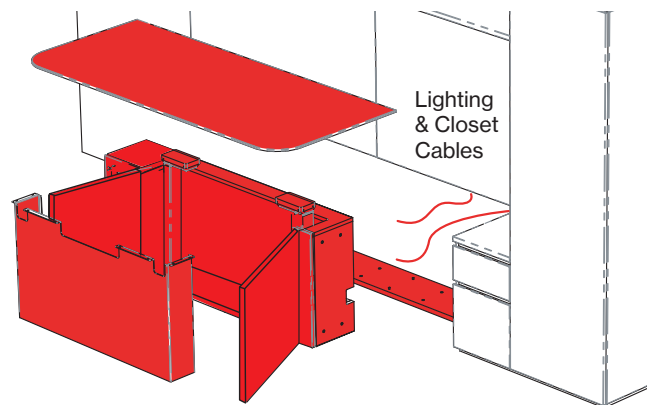

- Position and level desk plinth.
- Place case onto plinth.
- Route shelf and closet cables into case.
- Press clasps over leg assembly to install top.
- Lock with plastic clips. See following pages.
- Secure shroud using: #6 x 5/8\" pan head screws

# Pleat™ Collection Private Office Installation

## 05 INSTALL TABLE SWITCH & SHROUD

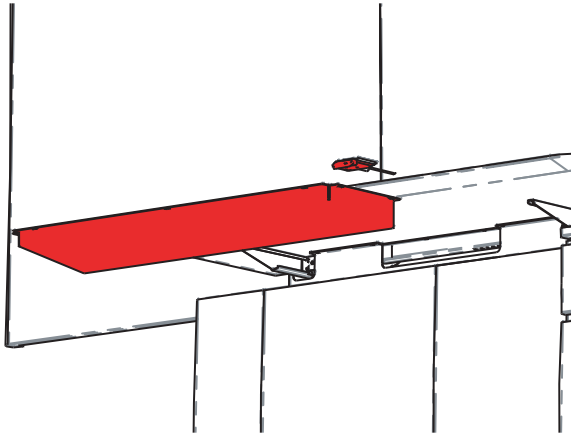

- Mount control switch to underside of top using:  
#6 x 5/8" pan head screws
- Complete all height-adjustable wiring before installing final wiring shroud.
- Secure shroud with:  
#6 x 5/8" pan head screws

## 06 ASSEMBLE FIXED TABLE

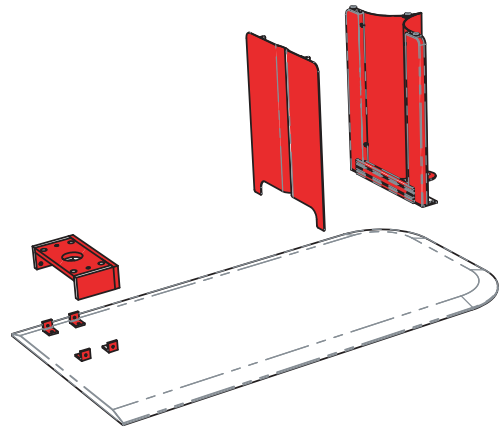

- Place fixed top face down on protected surface.
- Install stand-off box using:  
1/4"-20 x 9/16" joiner bolts
- Align open end toward flat side of table.
- Install Pleat base using:  
1/4"-20 x 7/8" joiner bolts
- Install removable base cover after table is upright.

## 07 INSTALL FIXED TABLE

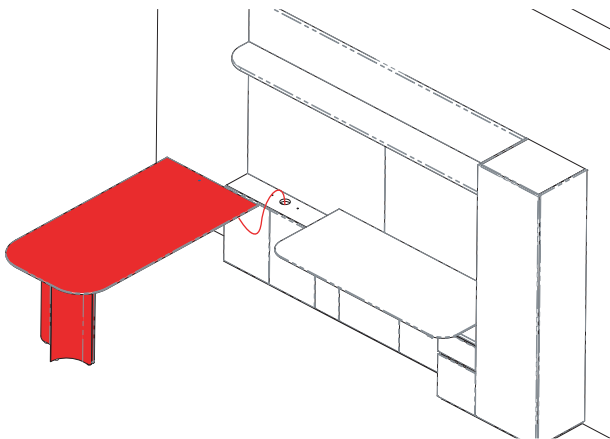

- Position and level fixed table plinth.
- Secure case using:  
1/4"-20 x 1 1/4" joiner bolts
- Feed light switch and wire through stand-off opening.
- Route wiring into case and connect to main unit.
- Secure table using:  
1/4"-20 x 1 1/2" joiner bolts

## 08 INSTALL LATERAL STORAGE

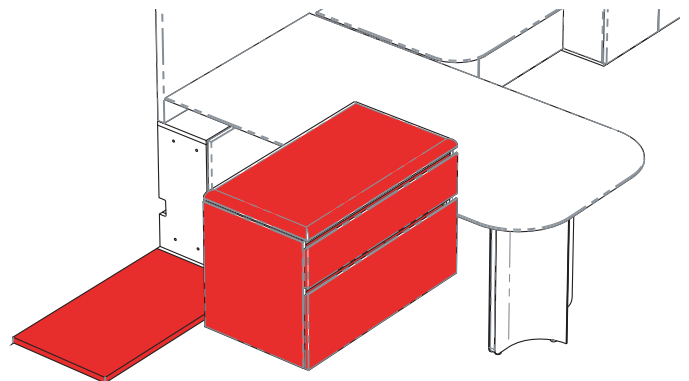

- Position and level lateral plinth.
- Place lateral case onto plinth.
- Secure using:  
1/4"-20 x 1 1/4" joiner bolts

# Pleat™ Collection Private Office Installation

## Wiring Details

Refer to diagram for:

- driver placement
- cable routing
- switch connections
- light locations

**Verify all lighting connections before powering system.**

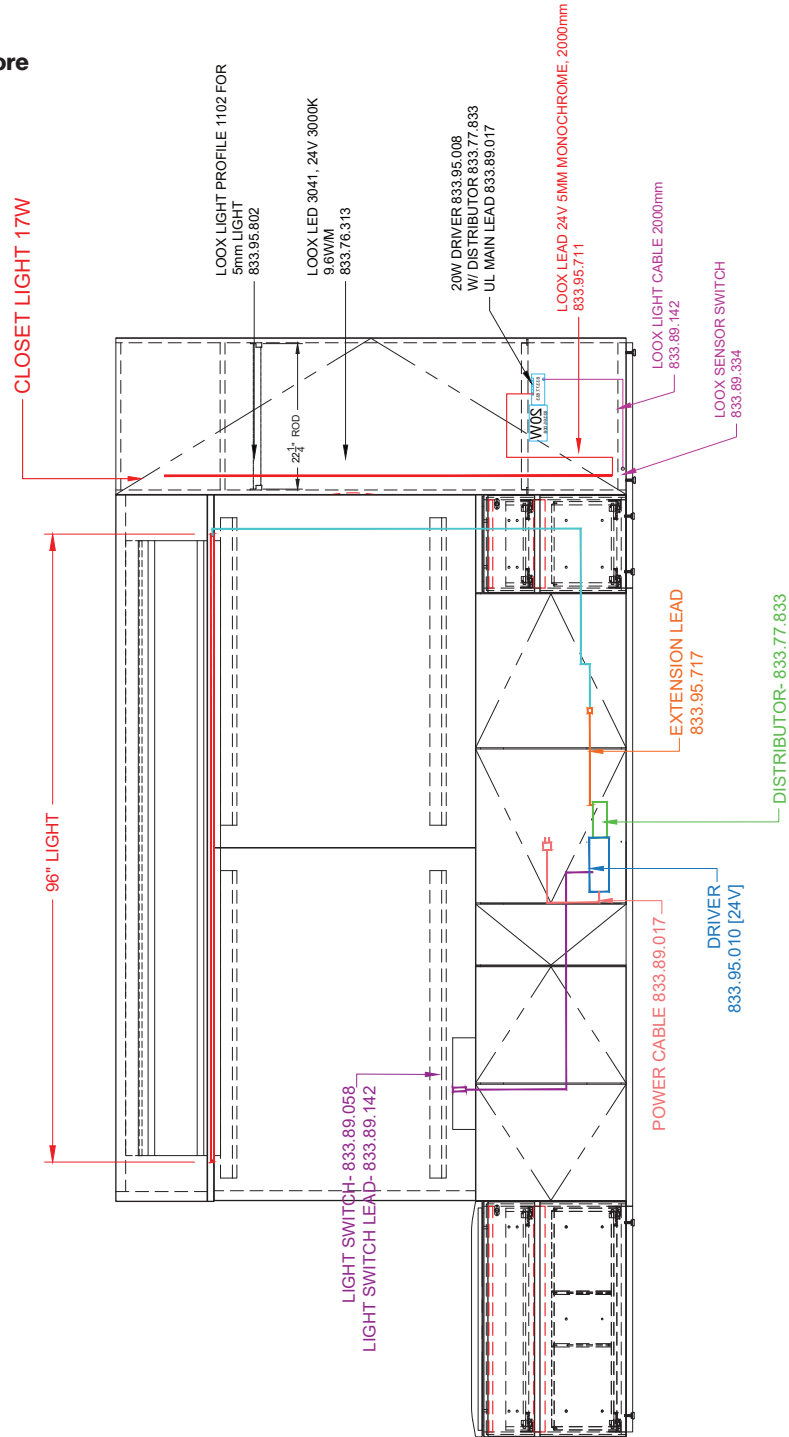

# Pleat™ Collection Private Office Installation

## Height Adjustable Leg Installation

1. Align leg assembly with mounting track.
2. Slide leg into position.
3. Install leg lock.
4. Secure clamp.
5. Press until fully engaged.
6. Verify lock is seated.
7. Repeat for opposite leg.

### HARDWARE:

A	Leg Assembly	Qty 2
B	Leg Locks	Qty 2
C	Leg Clamps	Qty 2
D	Table Top Assembly	Qty 1

