

# Pleat™ Private Office



design: REPUBLIC OF IIBYIV

Tailored form. Integrated performance

The Pleat™ Collection is defined by a single gesture, a fold, inspired by pleated fabric. This detail carries through each piece, creating a cohesive language for boardrooms, private offices, and collaborative spaces. A sculptural base, refined metal reveals, and tailored detailing come together to create a collection that is refined, versatile, and grounded in craftsmanship and precision manufacturing.



## DETAILS



**Adjustable Height**  
Height-adjustable system utilizes premium components paired with a Bluetooth® enabled programmable control system.

**Base Construction**  
Metal Reveal painted in any standard Nienkämper color  
Veneer Outer Wrapping  
Internal Wiring Capacity  
Levelers



## NEOCON 2026

### Finish Palette

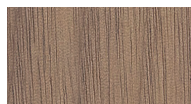

F-31FM  
Autumn Walnut Veneer  
Flat Cut Book Match  
Matte Finish

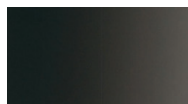

PC-04  
Dark Bronze  
Powder Coat Paint



Luum  
Bevel  
4038-01  
Tack Panel Fabric

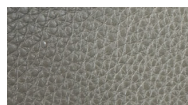

Leather  
Gaucho Clay  
Seat Cushion

### Integrated Power:



5 port Simple Forum

## Technical Drawings

Plan View

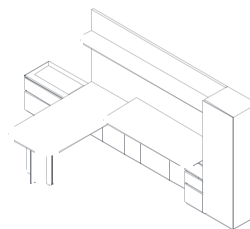
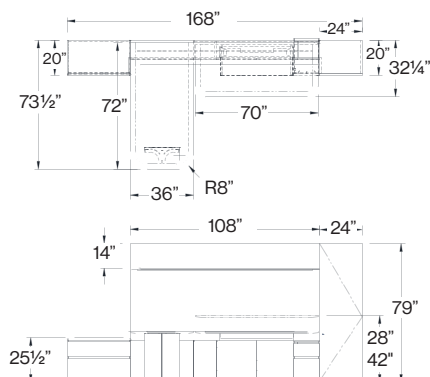

## SPECIFICATIONS:

### Top Finishes:

All standard Nienkämper veneer and plastic laminates including finger print resistant.

### Stains & Top Coats:

All standard Nienkämper stain colors and clear finishes (matte, 5, 10, 35, 45 degree sheen)

<b>Foot Print:</b>	168"x73½"
<b>Fixed Desk:</b>	72"x36"x29"
<b>Height Adj Desk:</b>	70"x30"x28"-42"H
<b>Soft Corners:</b>	8"Rad

### Fixed Pedestals:

1B/1F 15"x20"x27"H | 1B/1F Lateral 36"x20"x29"H

### Mobile Pedestals:

Available within collection

**Closet:** 24"x20"x78"H

### Closet Options:

Auto on LED closet light, hat shelf and mirror

### Locks:

Available within collection

### Floating Shelf:

108"x12½"x¾" - wood veneer with flush LED light

### Tack Panel:

108"x10" Veneer | 108"x55" Fabric

### Tack Panel Options:

Full fabric, Split material veneer & fabric (side by side or below and above shelf), Glass white board

**Base Style:** 20" Pleat Base

**Lighting:** LED

### Pulls:

Touch, Integrated Scallop, all std pull styles

### Cable Management:

Through Bases and concealed in cases with access panel

### Customization:

Top lengths & Configurations

## SPECIFIER SUPPORT:

### Lead Time

Standard 10 weeks / Custom 12 weeks

### Warranty

5 Years

### Power

UL, cUL & CSA Listed Components,

### Sustainability

FSC® Options Available | LEED Contribution

### Delivery

Protective Blanket-Wrap Shipping

### Made in

Canada