

ULTRA CONTROLO

ACIH®



ACIH

ACIH® Systems

The ACIH industrial hospital compressed air systems were developed to meet the needs imposed by hospital standards that prohibit the use of medicinal air for industrial purposes, requiring the existence of an independent supply with features that are appropriate to the equipment installed in hospital buildings. The design of ACIH systems is the result of our experience of more than 30 years related to compressed air and associated with leading global brands.

Regulation

The ACIH industrial hospital compressed air systems comply with the Machinery Directive and the ACSS ET 08/2010 technical specifications.

The ACIH systems resemble the requirements of standard ISO 7396-1 pertaining to redundancy, the command, control and alarm systems in order to ensure a continuous supply of air to the various pneumatic systems including the supply of the autoclaves for sterilization.

The design, production and assembly of the ACIH air systems follow the standards defined by the Quality Management System, ISO 9001:2015.

Reliable Construction

The ACIH systems are equipped with the most up-to-date technology in rotary screw compressors produced by Gardner Denver in its plant in Siemern, Germany.

The ACIH integrates, in its whole, air treatment systems that ensure the continuous supply of excellent quality air without loss of their filtration capacity over 6,000 to 10,000 hours of continuous service, thanks to the filtering means free from binding agents and the construction of their mechanical structure with stainless steel mesh.

We emphasize the importance of our built-in filtration systems that are properly sized to allow for very low pressure drops which represent huge energy savings over the years of use.

THE SMART CHOICE

Basic configuration

- 1, 2, 3 or more air compressors;
- 1, 2, 3 compressed air treatment and drying units with an electronic condensate drain, zero-loss;
- 1 electric control box;
- 1, 2 or more compressed air tanks;
- 1 or 2 sets of pressure reducers including sterile filter, ball valves and manometer;
- 1 oil/waterseparator for condensate treatment;
- 1 set of safety valves and safety devices for the good working and extended life of the equipment.

Note: The configuration does not include the power switchboard for the direct electrical supply to the compressors and respective cables. Normally the supply comes directly from a partial switchboard or a general switchboard from the customer plants.

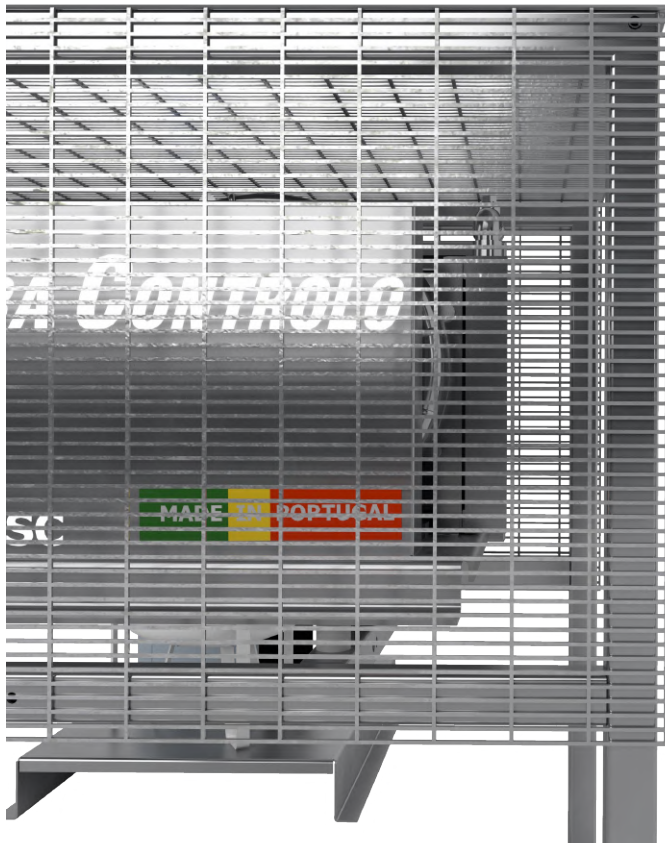

ADVANTAGES

ACIH with oil-free compressors

Upon request, the industrial hospital compressed-air systems, ACIH, can be built from totally oil-free compressors to meet the most stringent requests of 100% oil-free air quality.

ACIH also built considering the preservation of nature.

All systems are designed to minimize operating costs - less energy and parts - saving the environment.

COMPONENTS

Compressors

Rotary screw compressors equipped with high efficiency motors, suction air filter for dust protection, oil filter, high efficiency oil separator, air/oil and air/air heat exchangers, cyclone separator and digital control panel with information on inlet pressure and network pressure, alarms and alerts for preventive maintenance.

Tanks

Vertical configuration;
Capacities of 100 to 3,000 litres;
Hot-dip galvanized internal and external treatment;
Epoxy external finish;

Including safety accessories:

- Safety valve, calibrated manometer;
 - Manual bleeding valve;
- Connection for complementary emergency groups;
Electronic condensate drains.

Electric switchboard

Analogical control;
Digital control;
QuAir with digital console and communication with a PC.

Automatic oil/water separator

The ACIH system comes equipped with a condensate treatment unit which removes the oil, thereby allowing the draining of condensates into the sanitary network. The system includes a test valve to collect and analyse a sample of condensates before being introduced into the sanitary system.

Central de Ar Comprimido Industrial Hospitalar ACIH 3. ___/___D

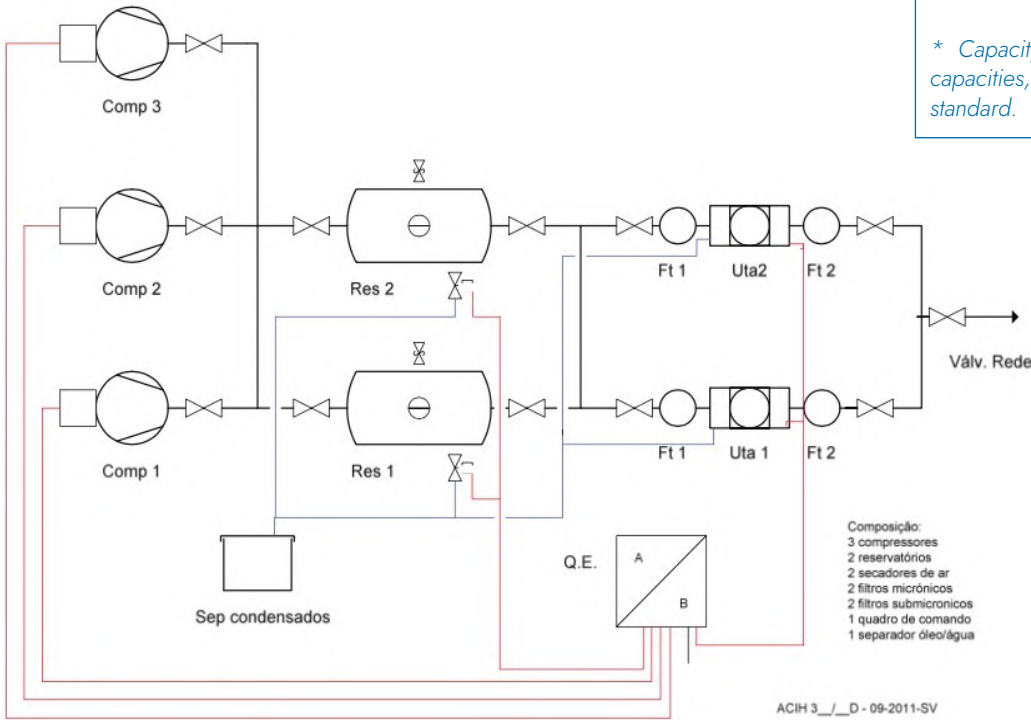

Technical data
 Normal service pressure 8-10 or 10-12 bar
 Normal capacities* 15 to 720 m3/h
 Power* 2.2 to 110 kW, 400V, 50Hz
 * Capacity and power per compressor. Other capacities, pressure and versions available as standard.

- Composição:
 3 compressores
 2 reservatórios
 2 secadores de ar
 2 filtros micrónicos
 2 filtros submicrónicos
 1 quadro de comando
 1 separador óleo/água

ACIH 3. ___/___D - 09-2011-SV

Typical ACIH diagram with 3 compressors + 2 tanks + 2 treatment units
 Other configurations available: E.g.: 3 compressors + 3 tanks + 3 treatment units

PROVEN QUALITY, YEAR AFTER YEAR

Gardner Denver compressors are in the hospital field for decades, all over the world!
 Hundreds of compressors installed in Portugal, working 24h/7 days a week;
 ACIH compressors air-end has 2 years guarantee and can be extended for 5 years!;
 Service Centre for hospital air systems compressors, certified under ISO 9001:2015 and ISO 13485:2016.

Gardner Denver Compressors

Compressed air in a hospital environment is a vital element for the functioning of health equipment such as autoclaves to sterilize surgical instruments, drying various materials, activation of valves and other pneumatically-powered medical devices. It is necessary to maintain a continuous and uninterrupted air supply to the industrial hospital compressed-air system.

Over the years, Gardner Denver compressors have proven to be heavy duty and reliable machines capable of complying with their mission to guarantee the continuity of air supply and adequacy to the supply regime of each hospital facility so as to safeguard the safety of its users, even in critical situations. Our compressors can work at room temperature of up to 50°C.

Advanced Control System Centralised Management System for controlling up to 12 compressors

The "GD PILOT" controller is a top of the range microprocessor based on a system which operates with a digital clock in real time. It ensures a reliable and safe operation of the compressor, managing its needs for medicinal air production for the network, and carries out a continuous monitoring of the operating parameters.

The 3 line display panel provides constant information on the temperature, internal pressure, pressure in the network, warnings, fault signals and preventive maintenance information. It has a set of programmable inputs and outputs able to meet information needs or the additional programming for centralised management systems.

The communication interface RS 485 - Modbus RTU allows communication with additional management equipment. The system is available in many common languages for easy understanding.

Intelligent Operating Modes

Compressor rotation in FIFO mode;

Compressor rotation by time;

Maximum efficiency - the most suitable compressor is used depending on the result of the algorithms;

Balancing of service hours to simplify the preventive maintenance actions.

GD PILOT 3-line LCD interface with the following views

1st line with permanent indication

Internal temperature of the compressor, in °C or °F;

Internal pressure, in bar or psi;

Air network pressure, in bar or psi.

2nd Line used for Navigation in the Menu

3rd Line with the indication of the status of the compressor

Ready to go;

Anomaly warning;

Operating state under load or empty.

Modern design

Gardner Denver has led the market, providing continuous improvements in the technology of screw compressors with fixed and variable speed units.

The unique design of the profile of the air-end screws, the innovative design

of the compressor with the main parts fully integrated in the block, including the separation of the oil, oil filter and by-pass temperature valve has reduced the number of components and external hoses resulting in an increase in reliability.

Made to last

Without an efficient and lasting air-end, a compressor with a unique design is worth nothing.

This is why Gardner Denver designs and manufactures this vital part in compliance with all standards. Thousands of GD screw compressors are operating around the world, showing that the "heart" of the machine can withstand the test of time.

GD PILOT - Provides the following information, in clear and readable text

Line pressure / discharge indication;

Air / oil temperature indication;

Total hours of operation and under load;

Indication of necessary maintenance;

Fault log monitor;

Real time clock;

Time controlled start / stop;

Remote start / stop;

Automatic start after power failure;

Secondary pressure regulation;

Operating / reset status indication.

GD SCREW COMPRESSOR COMPONENTS

1. Cooling fan

The appropriate and large fan capacity ensures the ideal cooling of the compressor allowing it to operate with maximum compression efficiency.

The ducting of the heated air to the exterior of the plant room can be done directly from the air cooling outlet. The compressor allows for a standard environmental temperature of 45°C. These are two factors which contribute to a reduction in the costs of electricity bills as, in most cases, the installation of an extractor fan is no longer necessary.

2. Exchangers

The compressor is fitted with a hot air/air plus air/oil heat exchanger, made in aluminium with a large area of dissipation to exchange heat. The exchanger is placed in a position which allows it to be easily cleaned.

3. Oil separator

The high efficiency oil separator reduces the residual oil content down to 2 ppm in normal compressor service conditions, thereby preventing the premature clogging of the air treatment system. This also avoids frequent refilling of the oil level and delivers good air quality downstream.

4. GD Pilot Controller

The intelligent microprocessor, included in the "GD PILOT" controller, monitors the entire activity of the compressor and is prepared for connection to a Centralised Management System.

5. Suction filter

The air intake filter placed at the entrance of the suction circuit has 99% efficiency with a special porosity of 1 µm. This protects the compressor against possible damage caused by aggressive particles which are suspended in the air and ensures an efficient operation of the compressor even in the worst working conditions.

6. High performance motor

The high efficiency electric motor (TEFC), IP55, class F and with shielded pulleys guarantees a long life cycle, without the need for periodical interventions.

7. The air-end

The air-end which is integrated in a single compressor block, fitted with an air intake valve, minimum pressure valve, oil separator, oil filter, oil sump, thermostatic oil valve and pressure sensors gives to the compressor high reliability.

8. Driving

The driving of the air-end is made by "V" belts or via a direct coupling, depending on the size of the compressor.

With modern vibro-acoustic optimisation techniques, the compressor works quietly, making very little noise.

9. Soundproofing canopy

The integration design of the compressor block inside a soundproofing canopy, and the insulation applied, provides excellent acoustic results, offering a low level of noise in accordance with ISO 2151 and ISO 3744.

Automatic Belt Tension

*Maintenance free system;
Offers a correct and constant tension during use;
Ensures a greater durability of the belts;*

As a benefit, an efficient transfer of power is guaranteed to the air-end, thereby saving energy.



Unique characteristics of the industrial hospital compressed air system ACIH

- Cyclone separators that prevent the degradation or malfunction of the drying system;
- Filter elements, free from binding agents, with a high particles dust content;
- Very low initial pressure drop resulting in energy savings;
- Automatic drains with test buttons, for operational control of the units;
- Fridge dryers properly sized for high ambient temperature and low pressure drops.

ACIH Guarantees

High efficiency filters with a guarantee of 6,000 to 10,000 hours of continuous service without the loss of initial filtration characteristics, providing significant energy savings and extended replacement intervals.

Ultradry Air!

The ACIH industrial hospital compressed air systems can be equipped with adsorption dryers for dew points of -20°C or -40°C and even with activated carbon filters.

Safe and Simple Assembly

The system is pre-assembled. Only the connection of the compressors to the tanks; from the tanks to the treatment unit modules connection to the air network are needed.

It can include all connection cables and flexible hoses and drainage kit with all pipes and pneumatic tubes and accessories. The ACIH is adjusted and tested at the factory and is ready to be installed at any given location. In medium and large systems, the pre-installation, the initial start-up and the training of staff is supervised by our skilled technicians.

Preventive Maintenance

The maintenance of the ACIH compressed air system is carried out regularly by technicians who are certified by Ultra-Controlo so as to ensure that the system is always in its initial conditions of use.

Behind each ACIH, there is a team of competent professionals who are trained by the manufacturers of the main components to take care of the equipment

RAISING THE MEDICAL GASES QUALITY STANDARDS

MODEL	COMPRESSOR FLOW M3/H 10BAR	MOTOR POWER KW	400V/50HZ	TANK LITRES
3.15/500D	3x14,4	3x2,2		2x500
3.20/500D	3x21,6	3x3,0		2x500
3.30/500D	3x31,8	3x4,0		2x500
3.40/800D	3x40,8	3x5,5		2x800
3.60/800D	3x63,6	3x7,5		2x800
3.100/1000D	3x96,1	3x11		2x1000
3.130/1000D	3x135,6	3x15		2x1000
3.170/1000D	3x164,4	3x18,5		2x1000
3.200/1000D	3x192,6	3x22		2x1000
3.300/1500D	3x301,7	3x30		2x1500
3.370/1500D	3x371,4	3x37		2x1500
3.420/2000D	3x421,2	3x45		2x2000
3.450/2000D	3x445,2	3x45		2x2000
3.600/2000D	3x572,4	3x55		2x2000
3.750/2000T	3x748,8	3x55		3x2000

MODEL	COMPRESSOR FLOW M3/H 13BAR	MOTOR POWER KW	400V/50HZ	TANK LITRES
3.50/800D	3x51	3x7,5		2x800
3.80/1000D	3x79,2	3x11		2x1000
3.110/1000D	3x108	3x15		2x1000
3.140/1000D	3x140,4	3x18,5		2x1000
3.160/1000D	3x156,6	3x22		2x1000
3.260/1500D	3x262,8	3x30		2x1500
3.320/1500D	3x319,2	3x37		2x1500
3.360/2000D	3x367,8	3x45		2x2000
3.500/2000D	3x496,2	3x55		2x2000
3.630/2000T	3x630,6	3x75		3x2000

