

The Sonus logo features the word "sonus" in a bold, lowercase sans-serif font. The letter "o" is stylized with a horizontal rainbow gradient bar passing through its center.

Sky Drop

Vertical Baffle



Sonus Felt

Adaptable Acoustics for Sophisticated Specifiers

Sonus Felt is where acoustic performance meets expressive form. Designed for clarity, made to last, and endlessly shapeable — this is sound softened with intention. From bold palettes to sculpted geometry, every product balances sustainability, durability, and design freedom in equal measure.

Specifications

Product Name	Sky Drop
Content	100% Polyester (PET) with a minimum of 60% recycled content
Thickness	12mm
Width	6.25"
Length	6.25"
Height	2', 3', 4', 6'
Tolerance	1/32"
Weight	1 lb per linear foot
Edge	Exposed Felt
Sound Performance	NRC = 1.0*
Fire Performance	Product made from Class A PET felt material tested under ASTM-84
Variations	Sonus Felt uses an industry standard felting process. Slight and consistent variations in color and "heathering" should be expected when using this sustainable material. Slight imperfections are within normal manufacturing tolerance and not visible in standard installations.
Maintenance	Vacuum to remove any loose dirt or dust. You may use a soft or plastic bristle brush to loosen it. Avoid excess pressure. Compressed air can also be used to dust the material in difficult or large installations. If stains are present, you may saturate a lint-free cloth with a mild detergent or soap and water solution.
Warranty	10 years
Unit of Sale	Per unit

*Depending on baffle heights and distance from the floor

Price



Snap the QR Code or visit sonusna.com to see pricing.

Sonus is the only manufacturer to have published universal pricing because:

- 1) We got nothing to hide.
- 2) We are here for you.

Details & Installation

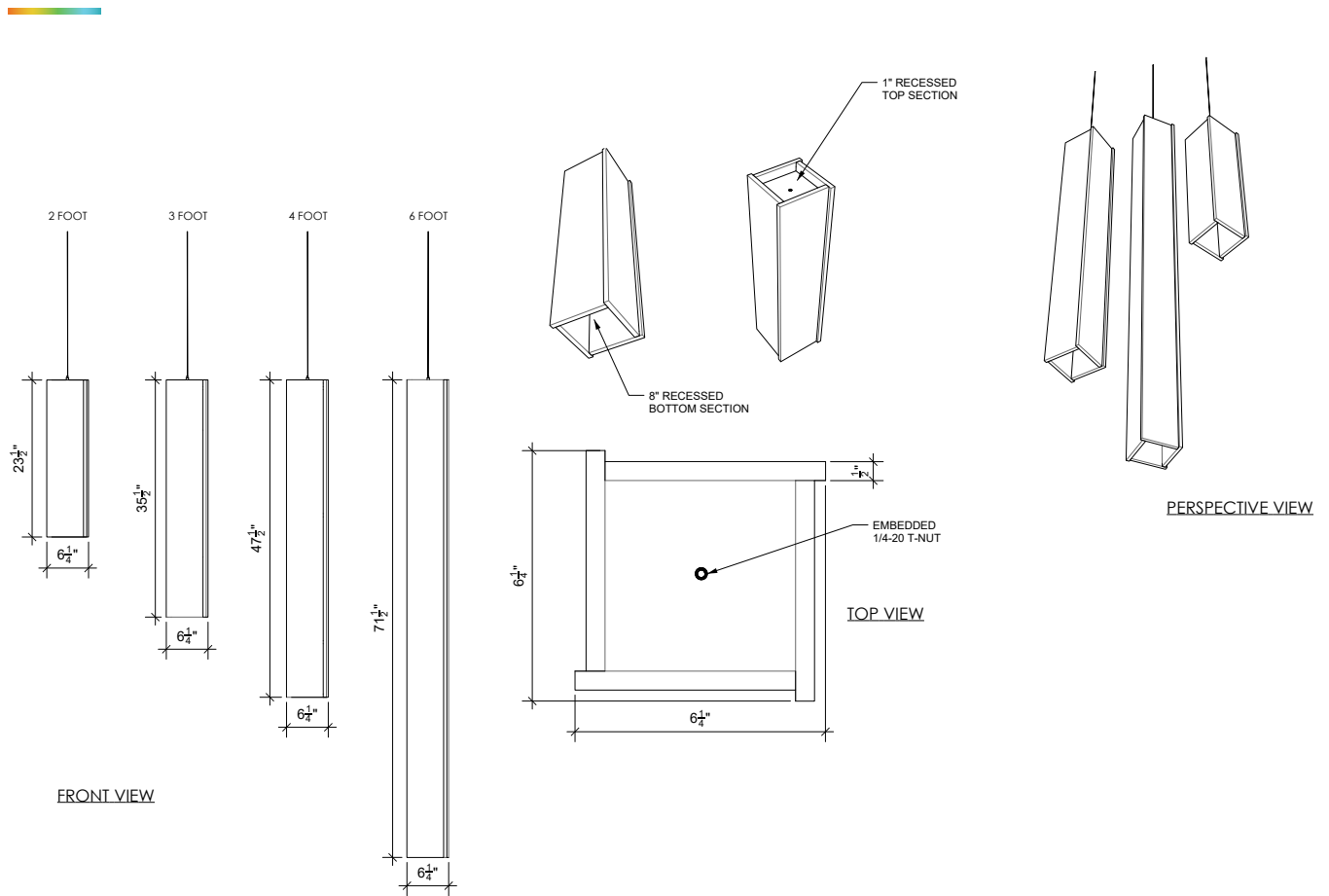

STEP ONE
 PRE-INSTALL 1/16" AIRCRAFT CABLE
 ONTO CEILING IN DESIRED
 LOCATION AND PATTERN

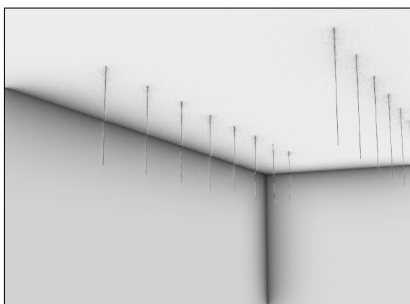

STEP TWO
 WITH CABLE GRIPPER PRE-INSTALLED
 LIFT BAFFLES INTO POSITION
 AND ATTACH CABLES

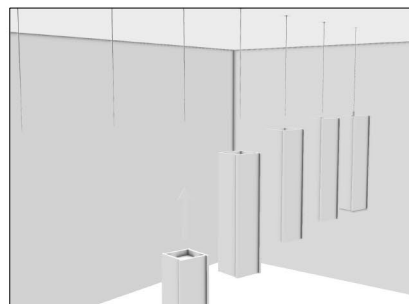

Specifications



Environmental

- Minimum 60% post-consumer recycled PET (third-party certified)
- 100% recyclable material composition
- Formaldehyde: Not detected
- Ultra-low VOC emissions (near-zero TVOC)
- Free of:
 - SVHCs (>0.1%)
 - Heavy metals & restricted substances (RoHS)
- Select products utilize mechanical joinery construction, eliminating the need for adhesives and enabling monomaterial recyclability
- Reduced reliance on chemical adhesives supports improved indoor air quality
- EPD-backed lifecycle transparency (ISO 14025 / ISO 21930)
- Designed for long service life (~30 years)

Certifications

- **GREENGUARD Gold Certified® (UL 2818)**
Certified for low chemical emissions supporting indoor air quality
- **OEKO-TEX® STANDARD 100 – Product Class I**
Tested for harmful substances and safe for direct human contact
- **Environmental Product Declaration (EPD) – UL Verified**
Lifecycle assessment providing environmental impact transparency
- **SCS Recycled Content Certified (≥60% post-consumer PET)**
Third-party verified recycled material content
- **Red List Compliant (LBC Framework)**
Free of chemicals of concern per Living Building Challenge criteria
- **REACH SVHC Compliant**
No Substances of Very High Concern above regulatory thresholds
- **RoHS Compliant**
Free of restricted heavy metals and hazardous substances
- **ASTM E84 – Class A Fire Rating**
Meets stringent fire performance requirements for interior materials