



# GO Optimized ESS

## EU Installation Manual



## Disclaimer of Warranties and Limitation of Liability

The information, recommendations, descriptions, and safety disclosures in this document are based on Tigo Energy, Inc.'s ("Tigo") experience and judgment and may not cover all contingencies. If further information is required, consult a Tigo representative. Sale of the product shown in this document is subject to the terms and conditions outlined in the Tigo warranty or other contractual agreement between Tigo and the purchaser.

THERE ARE NO UNDERSTANDINGS, AGREEMENTS, WARRANTIES, EXPRESSED OR IMPLIED, INCLUDING WARRANTIES OF FITNESS FOR A PARTICULAR PURPOSE OR MERCHANTABILITY, OTHER THAN THOSE SPECIFICALLY SET OUT IN ANY EXISTING CONTRACT BETWEEN THE PARTIES. ANY SUCH CONTRACT STATES THE ENTIRE OBLIGATION OF TIGO. THE CONTENTS OF THIS DOCUMENT SHALL NOT BECOME PART OF, OR MODIFY ANY CONTRACT BETWEEN, THE PARTIES.

In no event will Tigo be responsible to the purchaser or user in contract, in tort (including negligence), strict liability, or otherwise for any special, indirect, incidental or consequential damage or loss whatsoever including but not limited to injury to persons, damage or loss of use of property, equipment or power systems, cost of capital, loss of power, additional expenses in the use of existing power facilities, or claims against the purchaser or user by its customers resulting from the use of the information, recommendations, and descriptions contained herein. The information contained in this document is subject to change without notice.

## Document Revision History

Version	Date	Changes
1.0	n/a	Initial version

---

## Contents

Disclaimer of Warranties and Limitation of Liability .....	2
Document Revision History .....	2
Contents .....	3
Overview .....	1
Safety .....	2
Pre-Installation.....	3
Components of the system .....	3
Wiring Overview .....	4
Single-Phase AC Connections .....	4
Single-Phase DC Connections.....	5
Three-Phase AC Connections .....	6
Three-Phase DC Connections .....	7
Ground Connection .....	8
Installation .....	9
Place Batteries .....	9
Mechanical Installation (One Battery Tower) .....	10
Mechanical Installation (Two Battery Towers).....	13
Assemble and Mount the System Bracket.....	13
To mount the system bracket: .....	14
Install the Inverter .....	15
Install the Link.....	16
Wiring One Battery Tower.....	21
Create a PE cable connection .....	21
One Battery Tower System Overview .....	21
Wiring Two Battery Towers.....	25
Install TS4 MLPE.....	26
Install the Tigo Access Point (TAP) .....	28
Check Connections .....	29
Power On Sequence .....	30
Commissioning and Tigo App .....	30
Tigo ESS Operation Mode .....	31
Self-Consumption.....	31

---

Backup .....	32
Time of Use – Saver.....	33
Dynamic Rate.....	35
Reference .....	37
Torque Table .....	37
GO Logo Operation .....	37
Status LCD .....	38
Maintenance .....	38
Power Off the System .....	39
Error Codes .....	39
Inverter Codes.....	39
Battery Codes.....	41
Customer Support .....	42
Specifications.....	42
Warranty .....	42

---

## Overview

The Tigo EI Residential Solar Solution optimizes energy consumption based on rate plans and today's home energy needs. It uses the following hardware components:

- **EI Inverter** – A single- or three-phase Tigo EI Inverter may be installed as grid tied only or as part of an energy storage system when paired with a Tigo GO Battery.
- **EI Link** – The Inverter's Link component provides a single connection location for communications and AC/DC wiring.
- **TS4 MLPE** – Tigo's module-level power electronic (MLPE) components optimize solar module performance and provide module-level monitoring and rapid safety shutdown. A Tigo Access Point (TAP) enables wireless communication with TS4 components with a wired connection to the Inverter.
- **Battery management system (BMS)** – The BMS component provides protection, internal monitoring, and management electronics.
- **GO Battery Module** – GO Battery is a storage system composed by lithium-iron-phosphate (LFP) battery modules for use with Tigo single-phase and three-phase EI inverter

The **Tigo Energy Intelligence** Android/iOS mobile app enables easy system commissioning and provides comprehensive ongoing visibility into system and module performance.

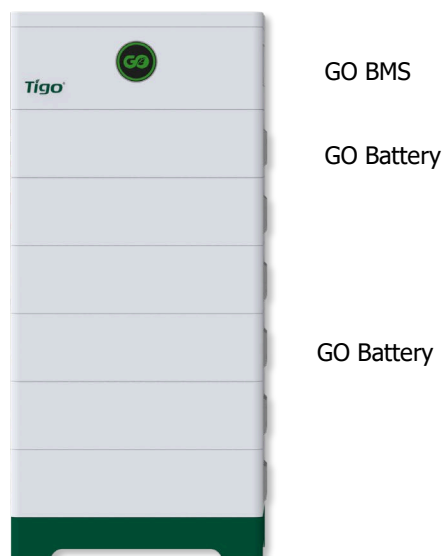
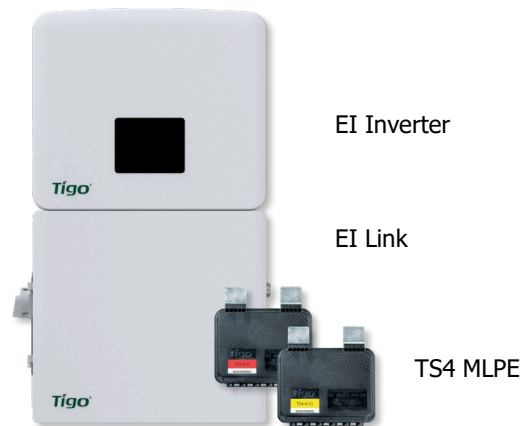

## Safety

The GO Optimized ESS must be installed and maintained by qualified personnel in accordance with local electrical codes. In addition:

- Components must operate within the technical specifications listed in their [datasheets](#).
- Failure to follow instructions herein may cause equipment damage not covered by the warranty.
- Use only copper conductors rated 75°C or higher. Do not use fine-stranded conductors.
- Unused conduit openings must be properly sealed. Connected conduit must use appropriate fittings.
- Always wear appropriate PPE and use insulated tools.

These safety symbols appear in the manual:



A hazardous situation which could result in severe injury or loss of life.



A hazardous situation which could result in minor or moderate injury and damage to the product.



An important operational note.

These symbols appear on Tigo enclosures:



Risk of electrical shock.



Risk of burns.



Check the operating instructions.



Caution, the Inverter may retain high voltage for up to five minutes after disconnection.



Avoid tampering.



Observe caution.

## Pre-Installation

### Components of the system

The default enclosure layout for an GO Optimized ESS is from the top down:

- Inverter
- Link
- Battery management system (BMS)
- Battery Modules:
  - Single-phase Inverter from 2 to 8 modules
  - Three-phase Inverter: from 3 to 13 modules
  - A second Battery tower is needed with more than 9 modules (from 10 to 13)

Locate GO Optimized ESS components:

- In a well-ventilated, easily accessible location.
- On a flat surface against a solid wall without tilt.
- Sheltered from direct sunlight and precipitation. The ambient temperature should be below 50°C.
- Away from antennas or other sources of strong electromechanical interference.
- Above potential flooding.
- With a minimum 300mm clearance around the top and sides.

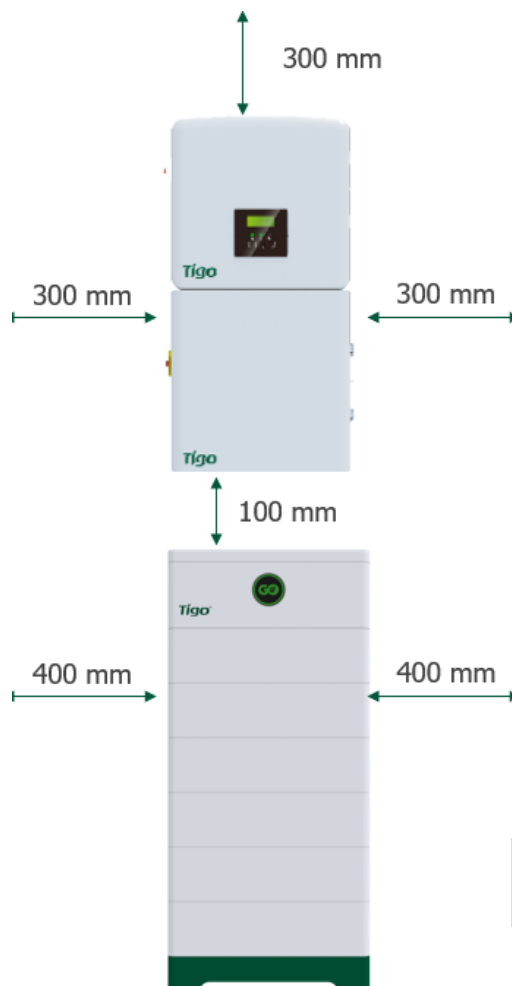

When using GO Battery EU, apply the GO Battery clearance requirements in addition to the EU specifications.

## Wiring Overview

### Single-Phase AC Connections

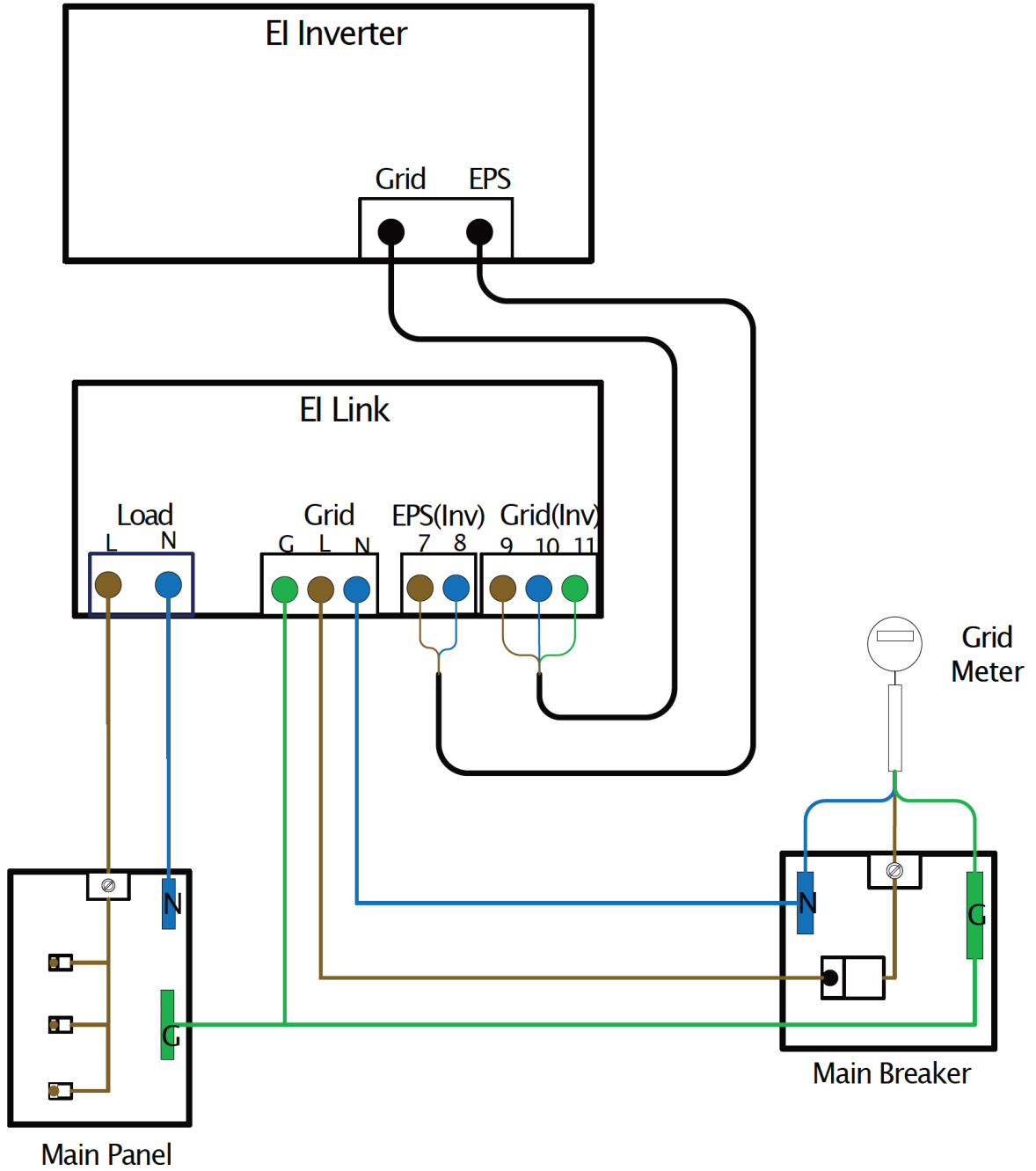

Single-Phase DC Connections

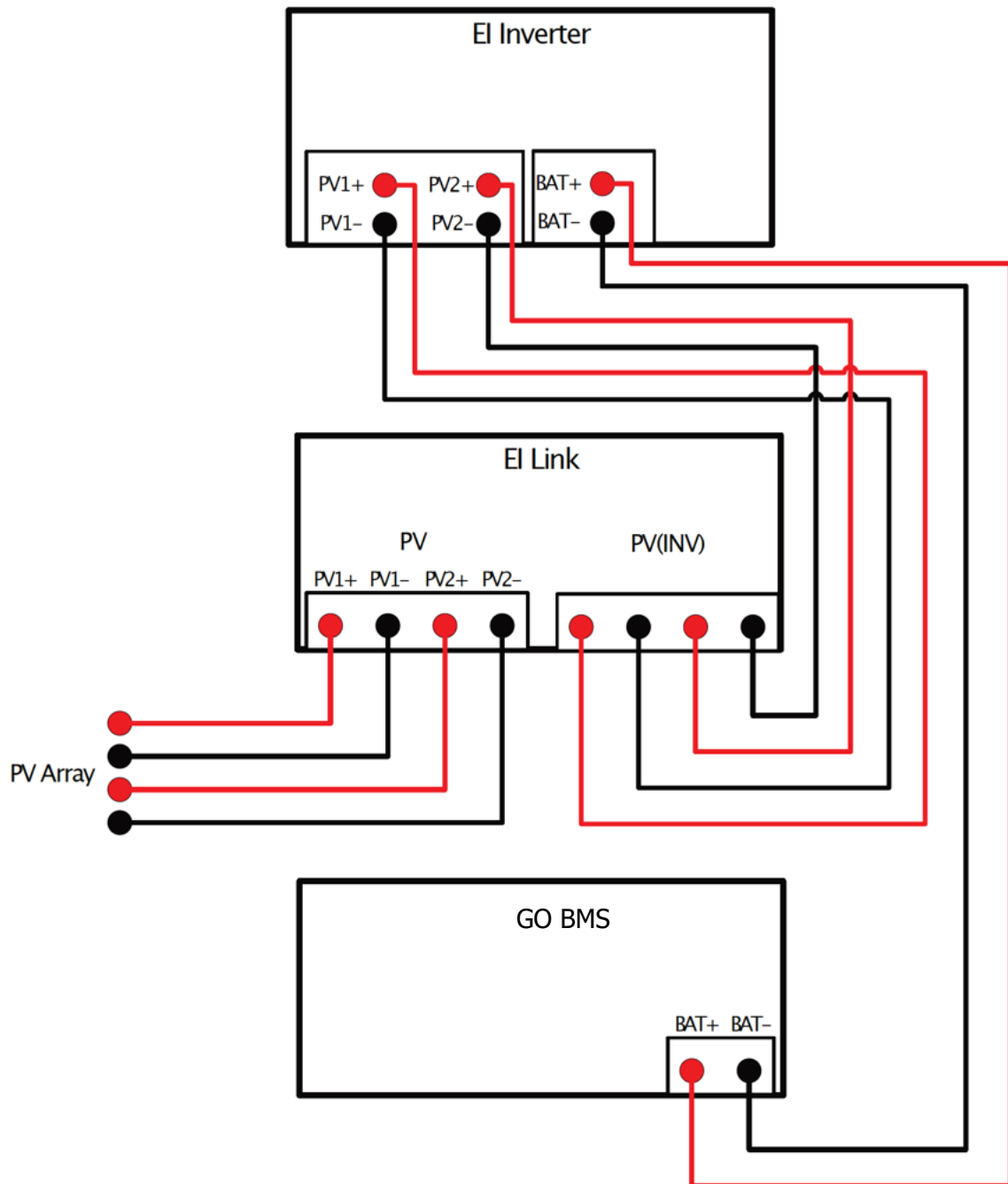

Three-Phase AC Connections

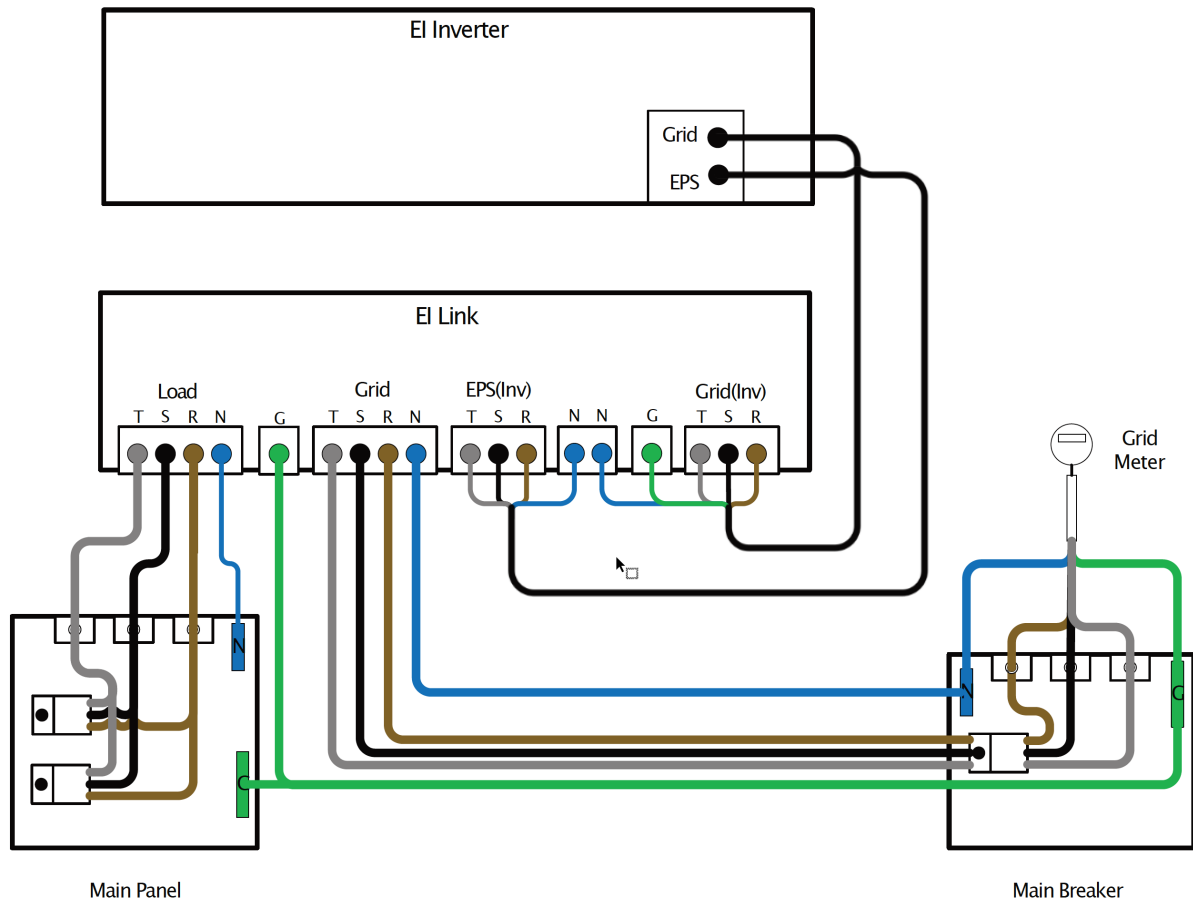

Three-Phase DC Connections

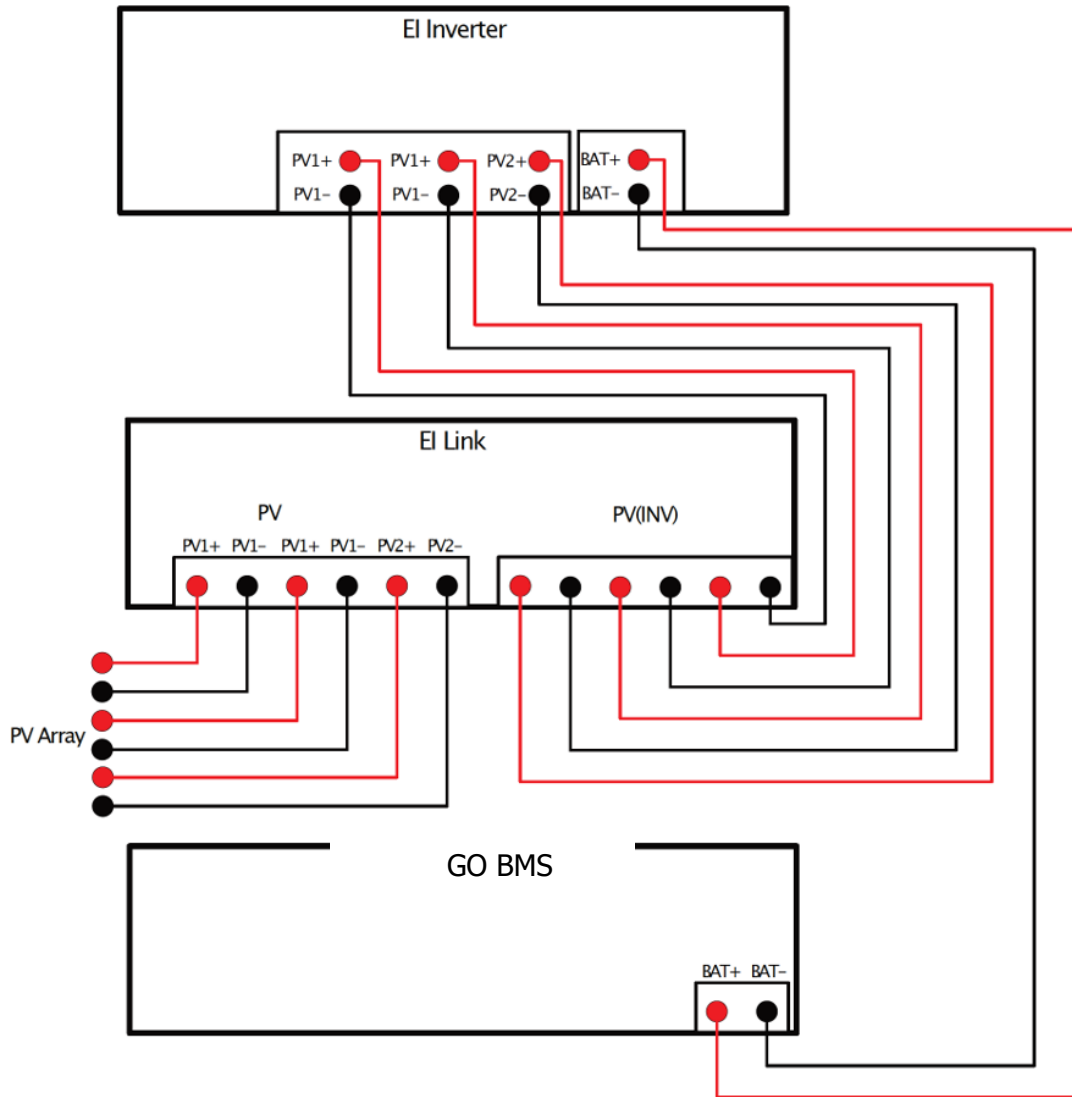

### Ground Connection

The EI solution requires TN-C/S or TT-C/S grounding.  
It does not support IT ground connection.

TNS 230V/400V

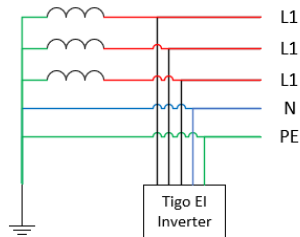

TNC-S 230V/400V

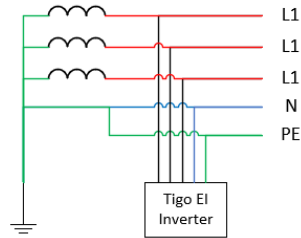

TNC 230V/400V

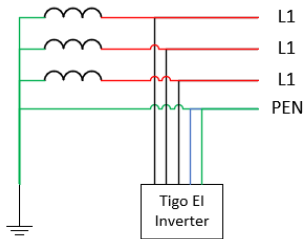

TT 230V/400V

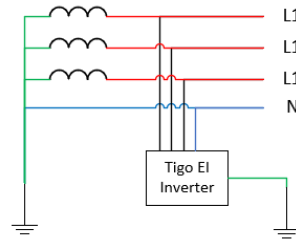

IT 230V/400V/600V

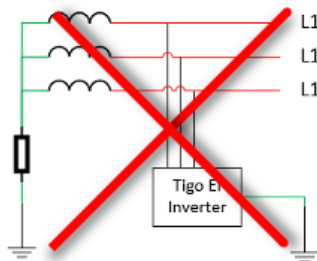

## Installation

---

To install the system, you will:

- Install first GO Battery and GO BMS (if present)
- Assemble and Mount the System Bracket of the EI Inverter and EI Link
- Install the Inverter
- Install the Link
- Install TS4 MLPE
- Install the Tigo Access Point (TAP)
- Connect Batteries Realize the electrical connections of the systems

## Place Batteries

The GO Battery package includes BMS components, Battery components, and Expansion Kit.

### **GO BMS**

- GO BMS
- Base
- Communication cable (GO BMS Port): 2000 mm
- Power cable (+/-): 2000 mm
- Mounting hardware (L-bracket, adjustable bracket, screws, washers, expansion bolts)

### **GO Battery Module**

- Battery module
- Screws and gaskets  
Battery

### **GO Expansion Kit**

- GO Expansion Box
- Base
- Communication cable (GO BMS Port): 2200 mm
- Heater cable: 2200 mm
- Power cable: 2300 mm (+), 2250 mm (-)
- Grounding cable: 2200 mm
- Mounting hardware (L-bracket, adjustable bracket, screws, washers, expansion bolts)

A GO system includes from 2 to 13 Battery modules. For installation with more than 9 modules, a second tower is needed.

- Single-phase inverter: 2–8 battery modules (7.3–29.4 kWh)
- Three-phase inverter: 3–13 battery modules (11.0–47.9 kWh)

## Mechanical Installation (One Battery Tower)

1. Adjust the base
  - Rotate clockwise to lower
  - Rotate counter-clockwise to raise

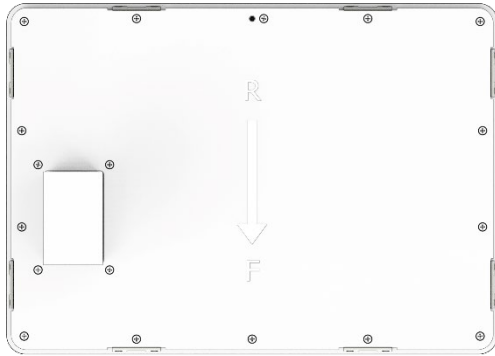

Top View

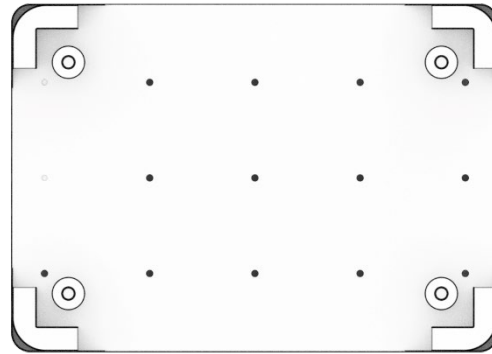

Bottom View

2. Place the base on the floor
  - Set 30–200 mm from wall (60 mm recommended)
  - "R" Rear Side, "F" Front Side of the Battery

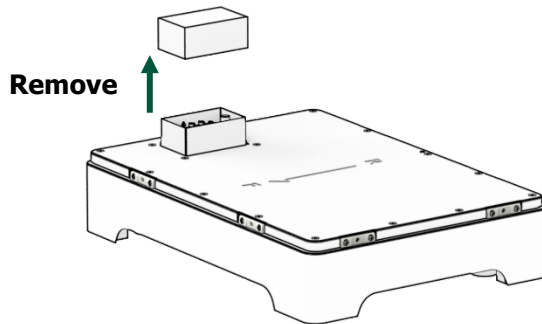

3. Remove the covers

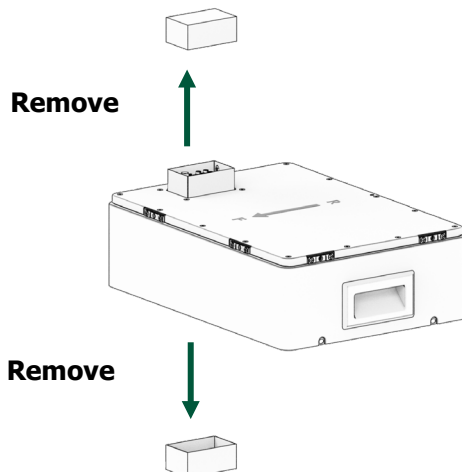

4. Place the Battery module. Secure onto the base.

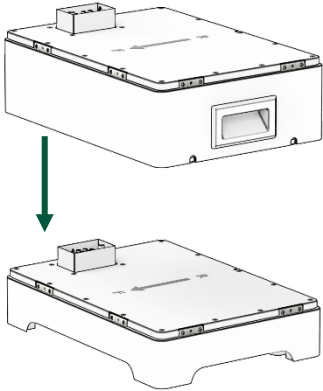

5. Secure the modules. Use the M4 screws and tighten them to the required torque.

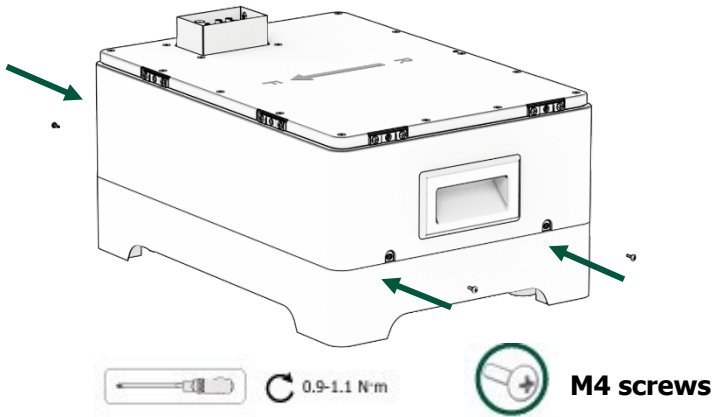

6. Install the adjustable bracket on the top Battery module Anchor it securely to the wall.

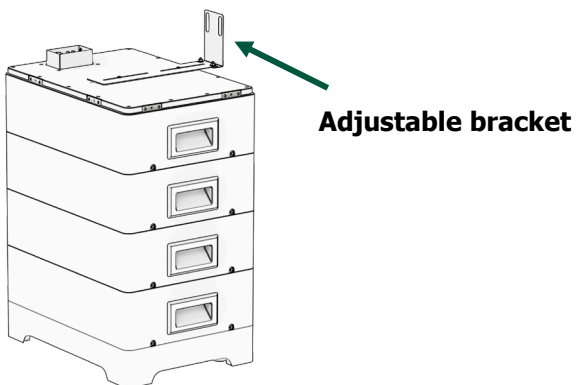

7. Place the GO BMS on the top

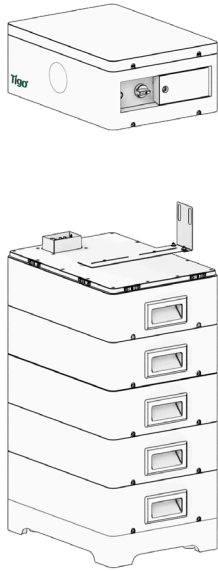

8. Secure the GO BMS with screws

- Tighten M4 screws
- Tighten them to the required torque

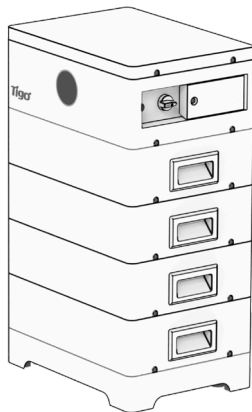

## Mechanical Installation (Two Battery Towers)

- Tower 2 installation requires a GO Expansion Box.
- Install tower 2 using the same steps 1-6 from Tower 1.
- Place the Expansion Box on top of Tower 2 (same as Step 7).
- Secure the GO Expansion Box using the same screw-fixing method shown in Step 8.
- Follow the Two-Tower Wiring section.
- Use one L-bracket and one adjustable bracket per tower.

### *Assemble and Mount the System Bracket*

The single-phase system bracket includes one vertical wall-mounting plates and two horizontal component-mounting plates found in the Inverter and Link packages:

- EI Inverter package: horizontal Inverter plate
- EI Link package: vertical Link plate and horizontal Link plate

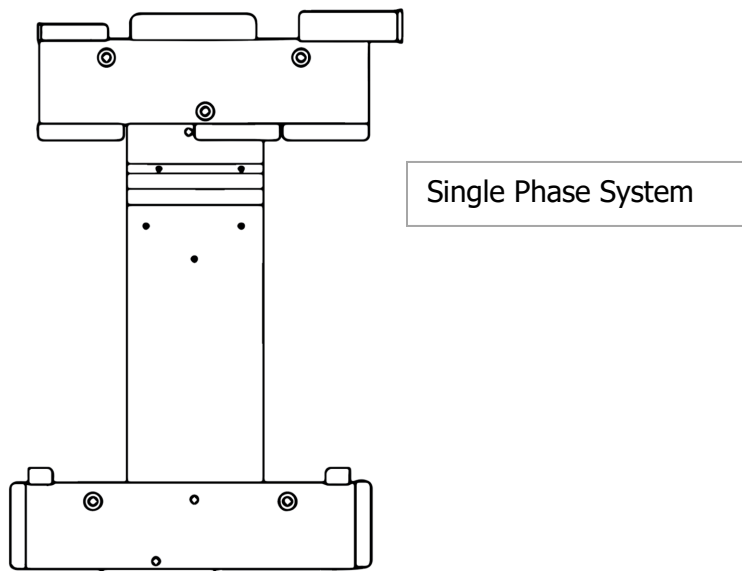

To assemble the system bracket, use M5 screws and GO Battery Ground Screw 4.5-5Nm.

1. Attach the horizontal Inverter plate onto the vertical Link plate. The vertical plate will rest against the wall.
2. Attach the Link horizontal plate onto the vertical Link plate.

The vertical BMS plate is only used when installing a single-phase EI inverter with EI Battery. Do not use it with the GO Battery system.

*To mount the system bracket:*

- Single – Phase: Mount the system bracket to the wall using appropriate mounting hardware at the locations. Ensure the vertical plates are plumb and the brackets are level.
- Single-Phase: Position the system bracket so the bottom of the Link plate sits at least 257 mm above the GO BMS box (see image).

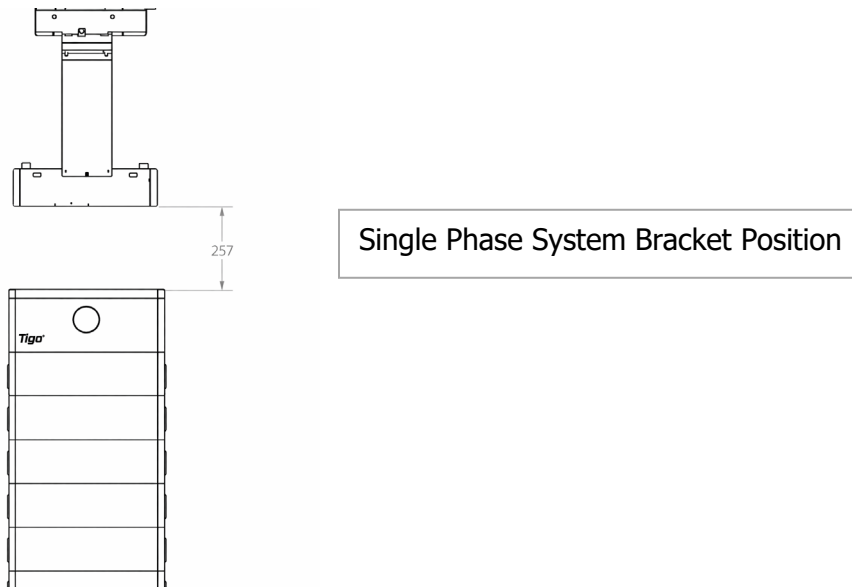

- Three-Phase: Mount the system bracket so that the bottom of the horizontal Link plate has at least 342 mm clearance above the top of the GO BMS box as in the picture.

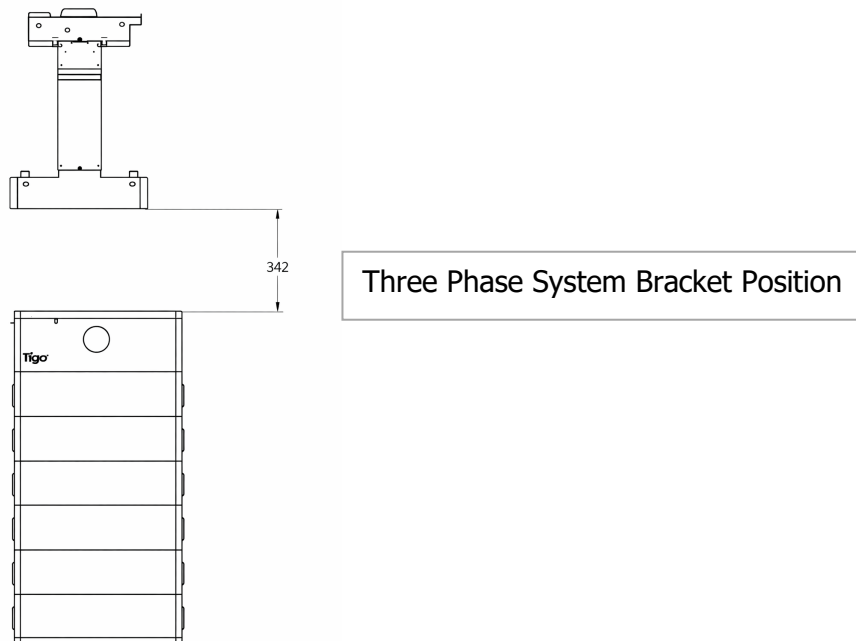

## Install the Inverter

The EI Inverter package includes:

- Inverter (single or three phase)
- Inverter horizontal mounting plate
- Wall anchor, washer, and lag bolt (3)
- M5 inner hex screw
- Waterproof RJ45 connectors (2 spares)
- RJ45 terminals (3, three phase only)
- Battery power cable connectors (2)
- Safety manual
- Quick Start Guide

To install the Inverter, slide it onto the horizontal Inverter plate and secure it using an M5 screw.

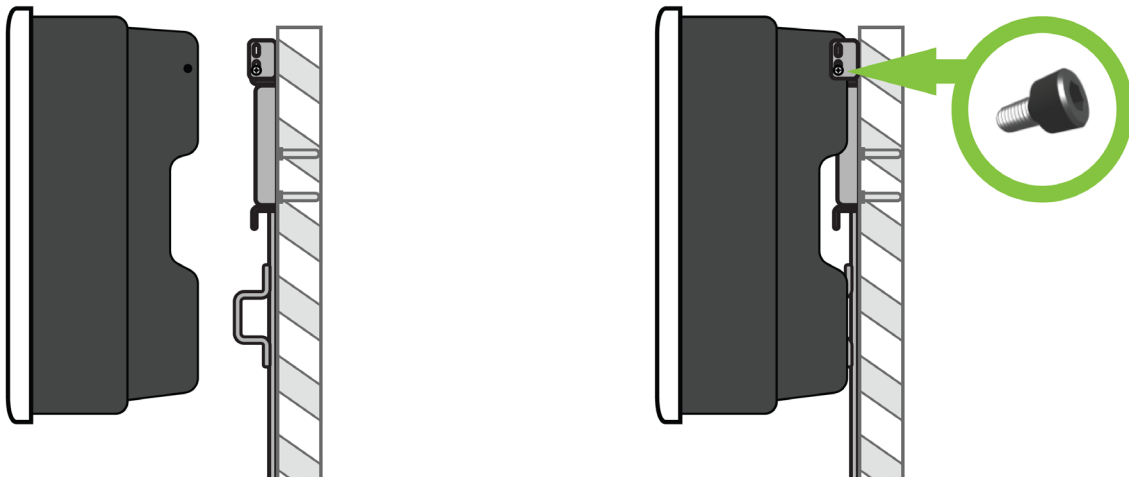

## Install the Link

The single-phase EI Link package includes:

- Link module
- 6mm ferrules (5)
- 16mm ferrules (5)
- 16mm ring terminal
- Flange nuts (4)
- Wall anchor, washer, and lag bolt (2)
- Ground Connection
- Quick Start Guide
- Horizontal Link mounting plate
- Vertical Link mounting plate
- Waterproof RJ45 connector (spare) 3
- CCA antenna
- Tigo Access Point (TAP)

The three-phase EI Link package includes:

- Link module
- Vertical Link mounting plate
- Horizontal Link mounting plate
- 6mm ferrules (8)
- Flange nuts (2)
- Wall anchor, washer, and lag bolt (2)
- 16mm grounding connection
- 16mm ferrules (10)
- Rubber plugs (2)
- Tigo Access Point (TAP)
- Waterproof RJ45 connector (3)
- CCA antenna
- Quick Start Guide

To install the Link and connect it to the Inverter:

1. Crimp ends of all unterminated conductors with ferrules and ground connection terminals and torque to 1.5Nm.
2. Slide the Link onto the horizontal Link plate and secure it using an M5 screw.

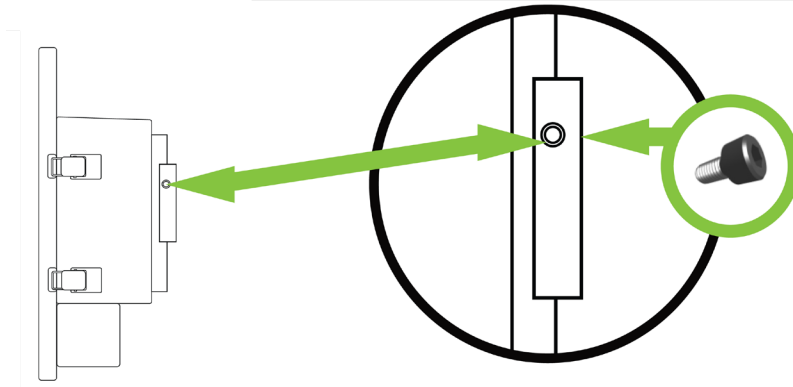

3. Connect the preinstalled Inverter ground connection cable to the Link.

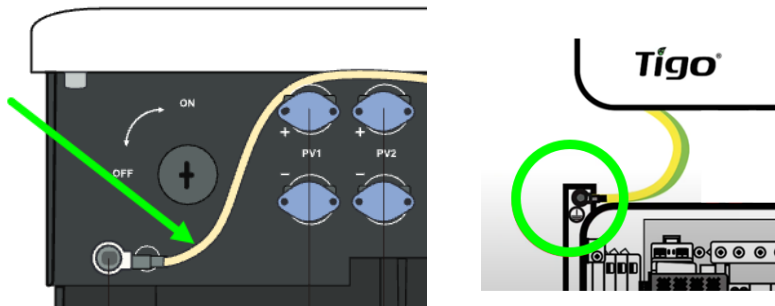

4. Connect the COM and CT cables to their respective connections at the bottom of the Inverter and the Link.

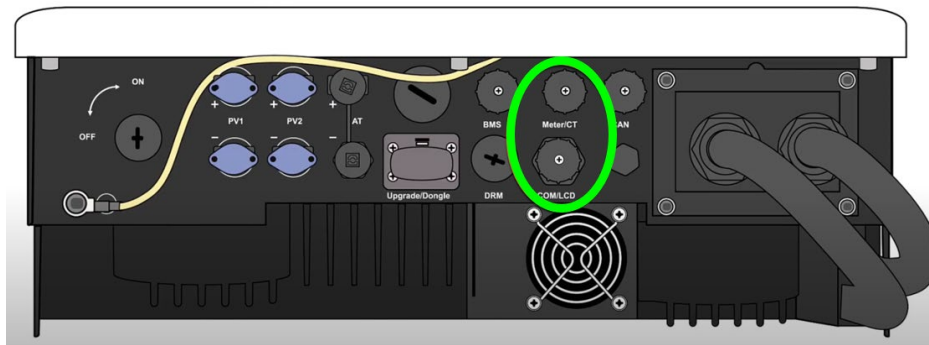

5. Remove the Link safety cover.

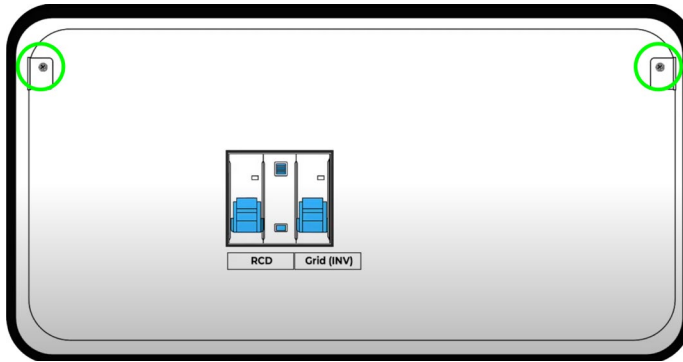

6. Run the preinstalled EPS (INV) and GRID (INV) cables from the Inverter through their respective ports on the bottom of the Link.

Single phase:

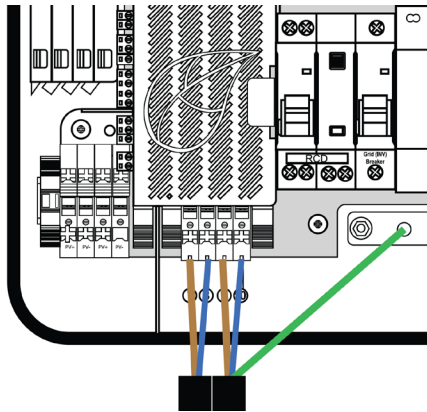

Three phase:

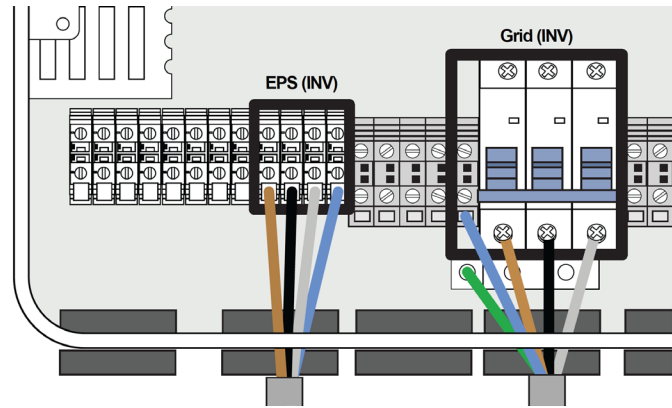

7. Connect the GRID (INV) ground connection wire to the Link ground connection bar.

To make Link AC connections:

1. Single phase: Connect conductors from a breaker on the house main breaker panel to Link grid terminals.

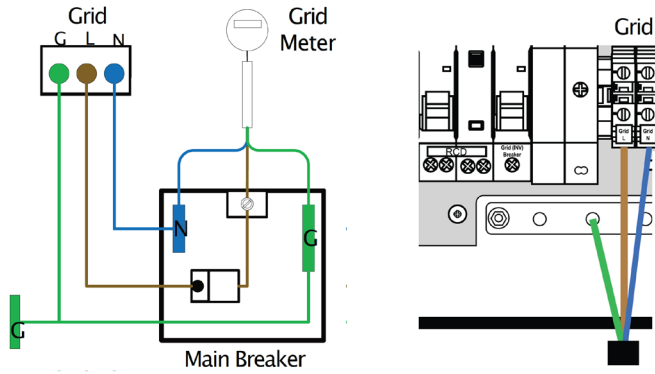

Three phase:

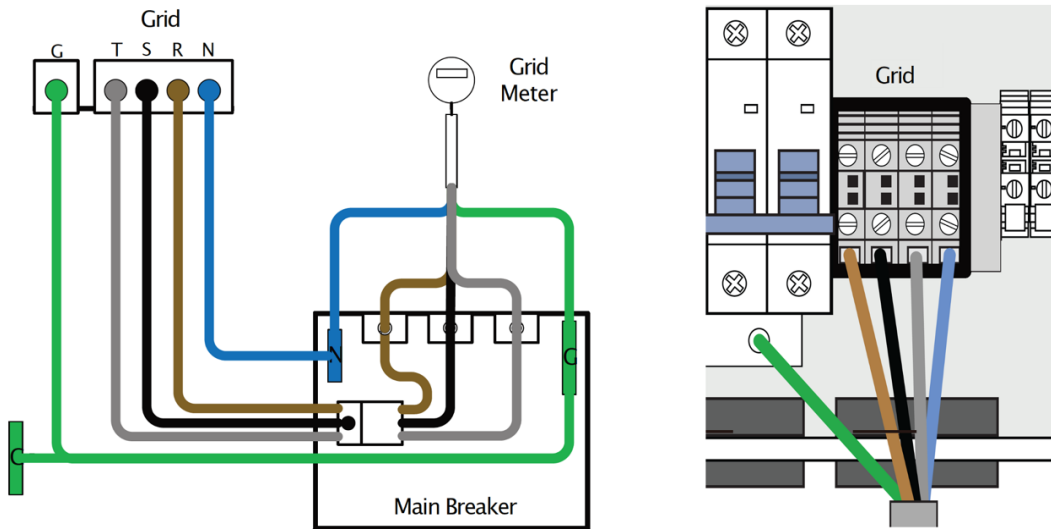

2. Connect the GRID grounding wire to the Link grounding bar.

3. Connect conductors from a breaker on the house breaker panel or backup load panel to the Link LOAD terminals.

Single phase:

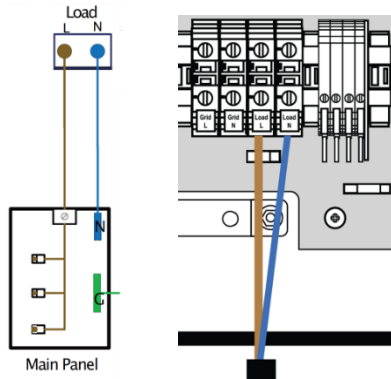

Three phase:

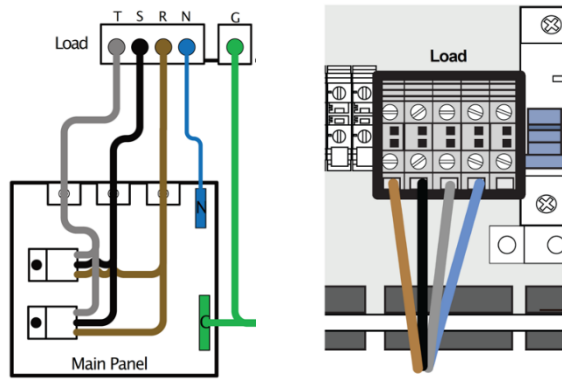

To connect PV strings to the Link, run the PV conductors through the Link PV port and connect them to their respective PV + and – terminals.

Single phase:

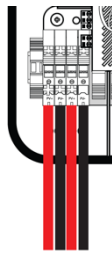

Three phase:

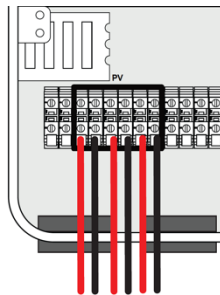

To enable the Cloud Connect Advanced (CCA) data hub:

1. If using Wi-Fi, screw the CCA antenna into the Link.

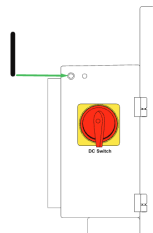

2. If using a wired network connection, connect the cable to the Ethernet port on the bottom of the Link.

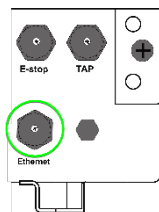

## Wiring One Battery Tower

### Create a PE cable connection

- Wired size 6 mm<sup>2</sup>
- The user must prepare PE cable

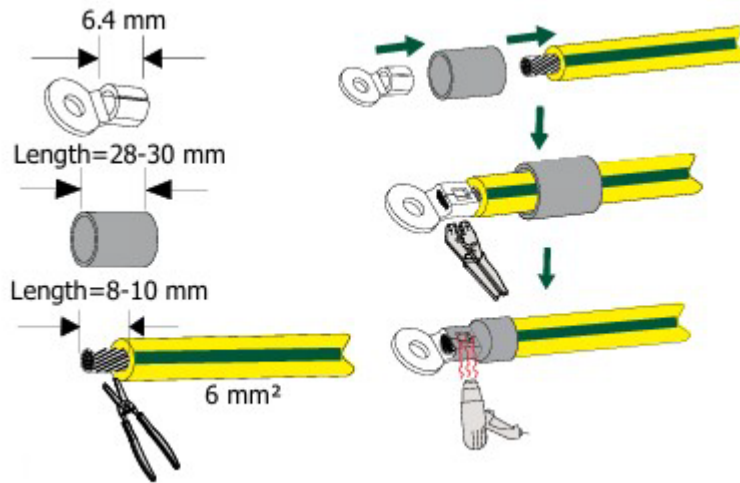

### One Battery Tower System Overview

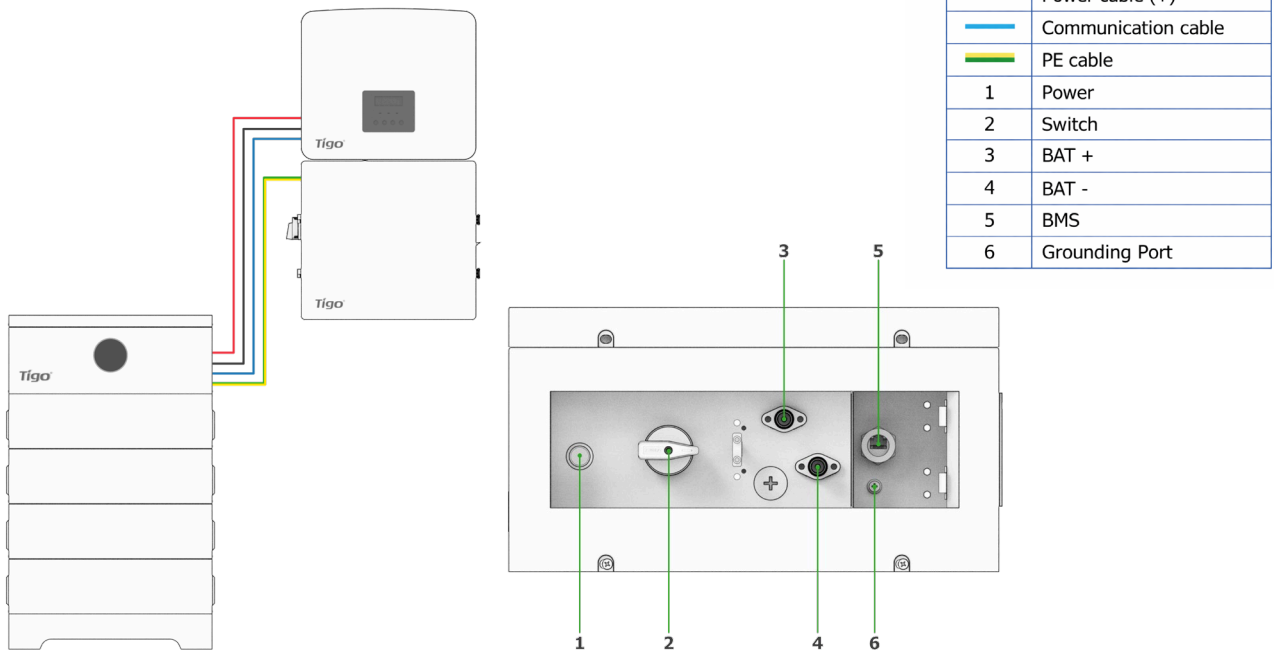

**All lock types are shipped in the OFF position.**

1. Unlock the door

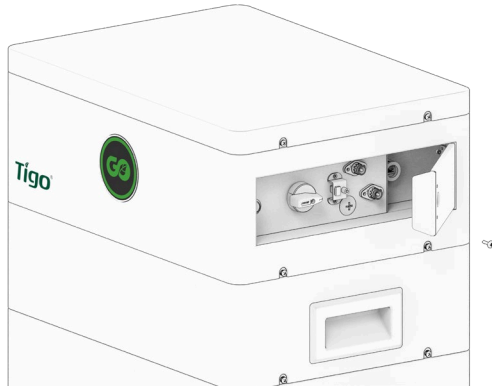

2. Connect PE Cable from GO BMS to EI Link

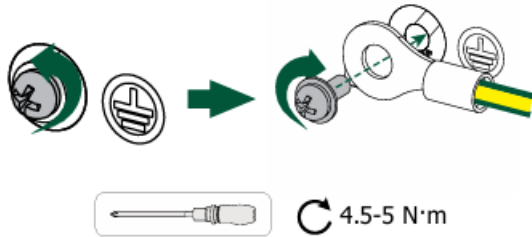

- Prepare and connect an grounding cable between the EI Link and BMS grounding connection.

EI Link grounding connection:

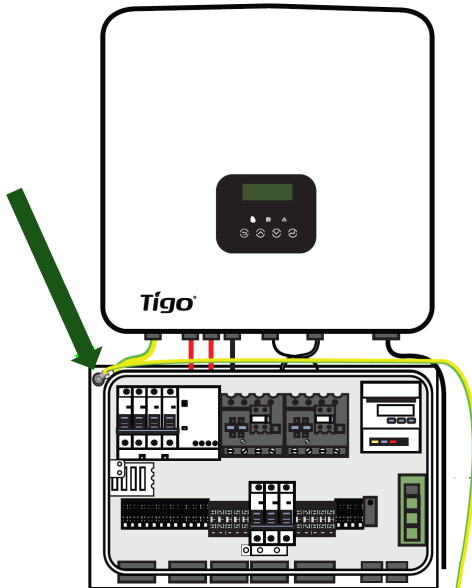

BMS grounding connection:

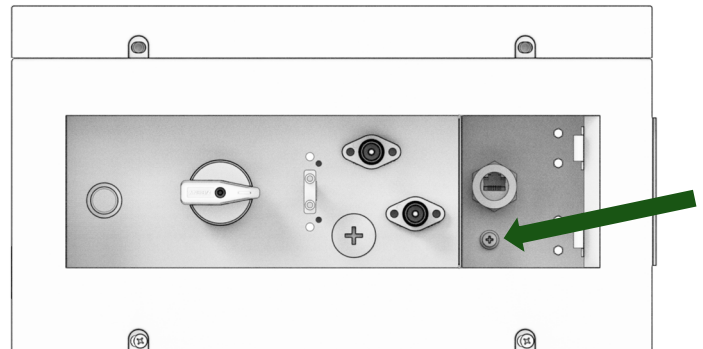

3. Connect Communication Cable between GO BMS and EI Inverter

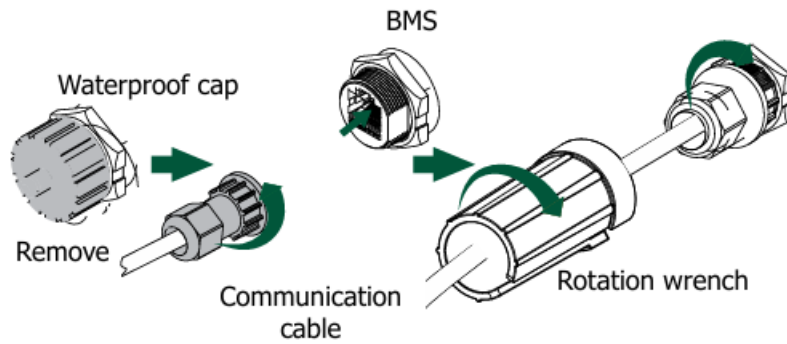

Connect one end of the BMS COM cable to the Inverter BMS port and the other end to the BMS port labeled BMS.

Inverter BMS port for COM cable:

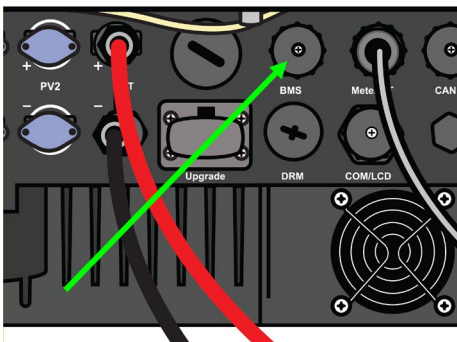

BMS port for COM cable:

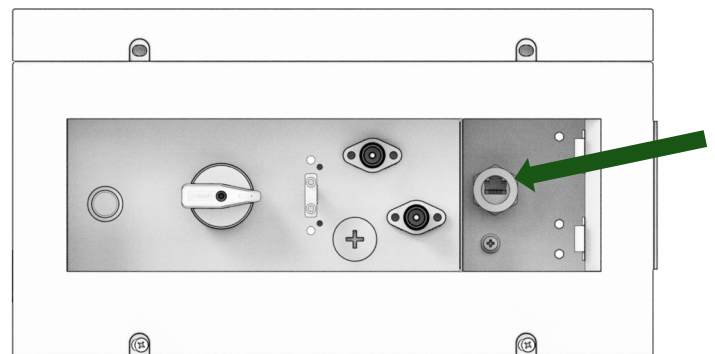

4. Connect Power - (BAT -) and Power + (BAT +) from GO BMS to EI Inverter

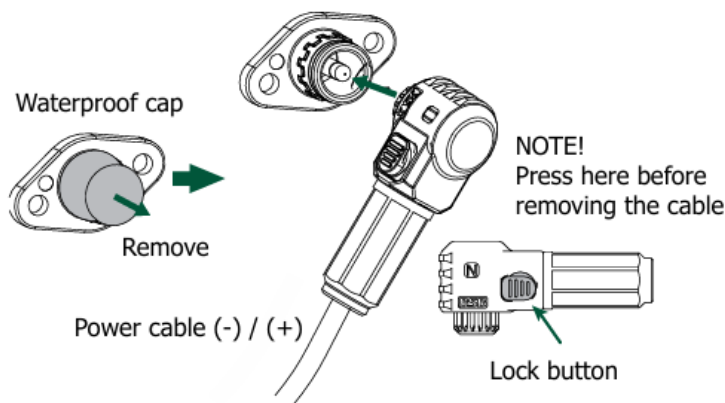

Connect one end of the prepared Battery charging cables to their respective Inverter BAT ports and the other end to the BMS BAT ports.

Inverter BAT ports:

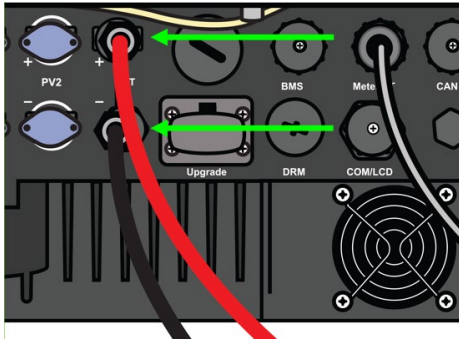

BMS BAT ports:

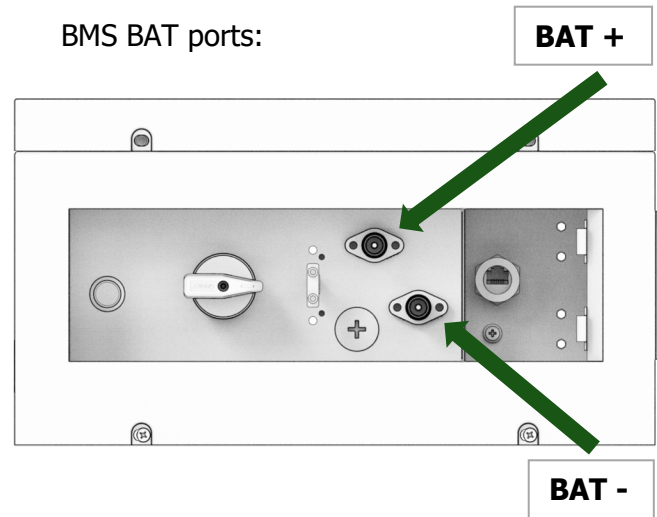

5. Push the BMS housing to engage the locking tab. Tighten the screw to close and secure.



## Wiring Two Battery Towers

Repeat Steps 1–5 for a one tower system. The next steps describe the GO BMS and GO Expansion connection for a two-tower setup.

1. Open doors on BMS and Expansion Box
2. Connect PE Cable
3. Connect Communication Cable
4. Remove heater cup and connect heater cable

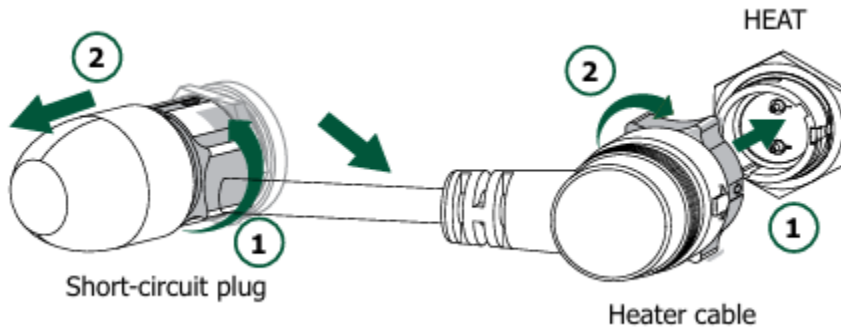

5. Remove the short power cable on both side of B - and B +

**NOTE!**  
Press here before removing the cable

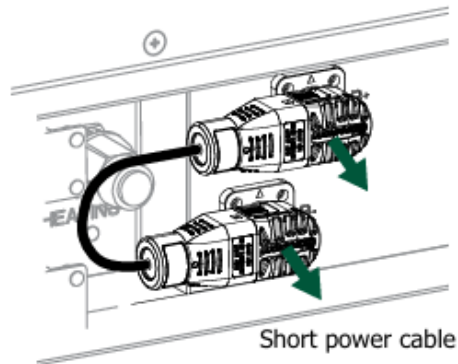
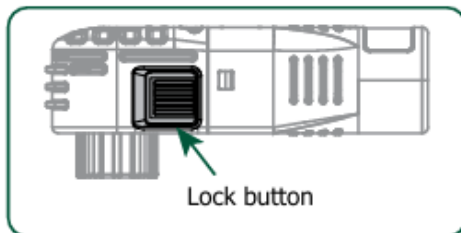

6. Connect Power - (B -) and Power + (B +)

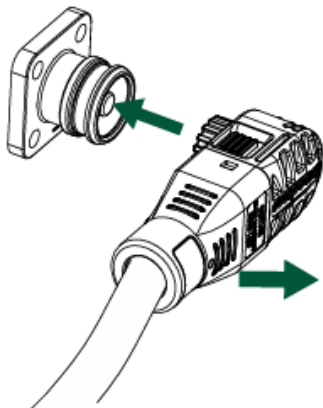

## Install TS4 MLPE

To install TS4 devices and map them for the Tigo Energy Intelligence app:

1. Attach a TS4 device to a PV module frame using silver clips. If using frameless modules, remove the clips and bolt the TS4 directly to the PV rail with M8 bolts. No additional grounding connection is required.



You must connect the shorter TS4 input leads to the PV modules first. Failure to do so can damage the TS4 unit.

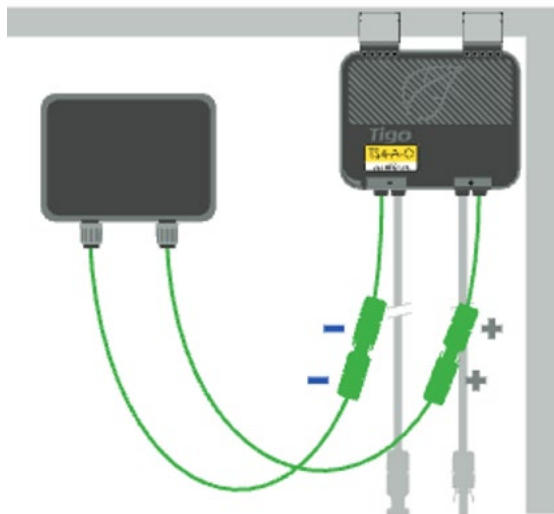

2. Remove the barcode sticker on the TS4 and place it on the PV array map located at the end of the EI Inverter Quick Start Guide. Ensure the sticker matches the physical location of the module on the roof.

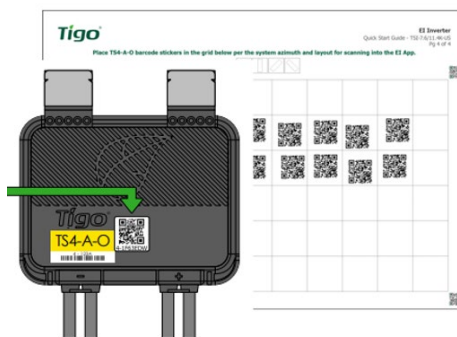

3. Connect the longer set of TS4 output cables to the neighboring TS4 to create a string.

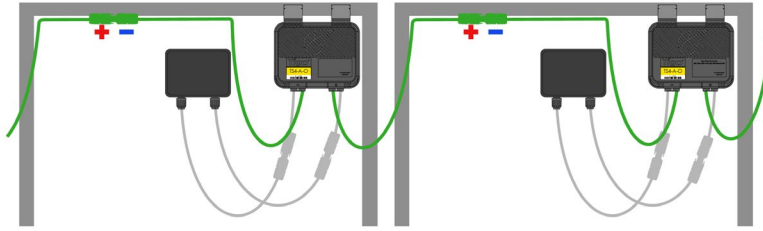

4. For TS4 installation data specific to your Tigo MLPE (TS4-A, TS4-O, etc.), scan the following QR code:

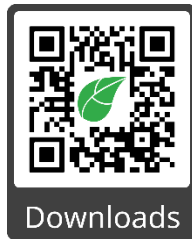

## Install the Tigo Access Point (TAP)

A TAP wirelessly communicates with TS4 devices to gather data and perform rapid shutdowns. The TAP connects to the Link via a T568B-scheme CAT5/6 cable.

Install the TAP centrally in an array for best coverage. Ensure there are no obstructions that may interfere with the TAP signal to other TS4 units in the array. If the array has multiple roof planes, you may need to install another TAP.

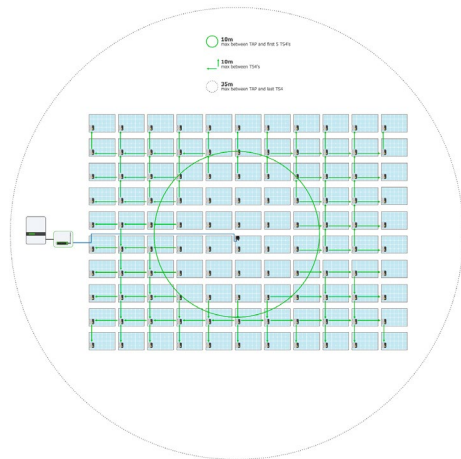

The TAP communicates directly with any TS4 within 10m. Each TS4 can relay data to and from another TS4 within 10m. The TAP can communicate with any TS4 within 35m.

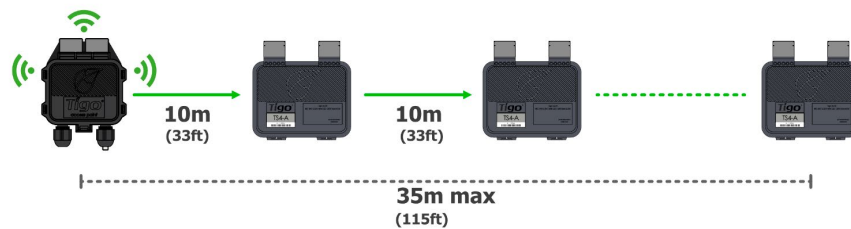

To install a TAP using a T568B-scheme CAT5/6 cable:

1. Connect cable wires to the left side of the TAP using either the quick-connect or the terminal block.

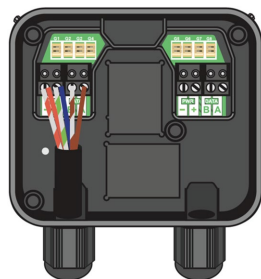

Wire Colors	TAP Terminal
Orange + Orange-striped	PWR-
Blue + Green-striped	PWR+
Brown-striped	Data B
Brown	Data A
Green, Blue-striped	Not used

2. Use the right-side terminals to connect a cable to another TAP. If there is only one TAP, leave the terminating jumper in the right-side terminal block.

3. Attach the TAP to the PV module the same way as the previous step for the TS4. For frameless modules, remove the silver clips and bolt directly to the rail.
4. Run the CAT5/6 cable to the Link and connect the RJ45 plug to the TAP port on the bottom of the Link.

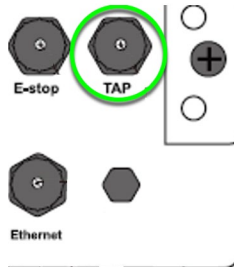

## Check Connections

Before powering on the system, double-check:

- Inverter–Link connections:
  - CT
  - COMM
  - EPS (INV)
  - GRID (INV)
- AC/DC connections to breaker panels.
- Battery power and COM cables.
- Grounding cables and connections.
- Conduit attachments are sealed and bonded where necessary.
- Unused conduit openings are fitted with waterproof caps (provided) or were left unopened.
- The Battery power switch and all other power sources connecting to the system are OFF.

## Power On Sequence

1. To turn on: switch to ON, then press the button.

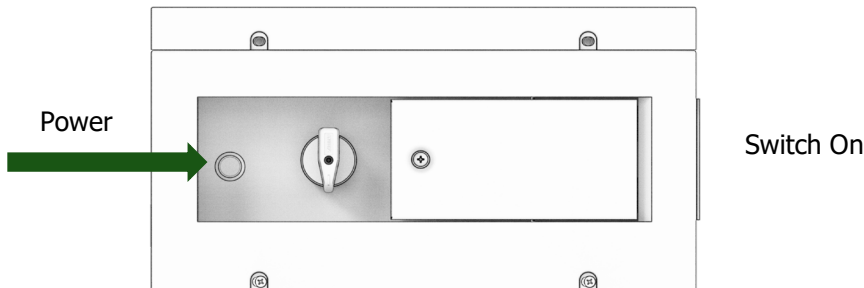

3. Press the BMS power button to start the Battery.
4. Turn on the DC switch on the left side of the Link.

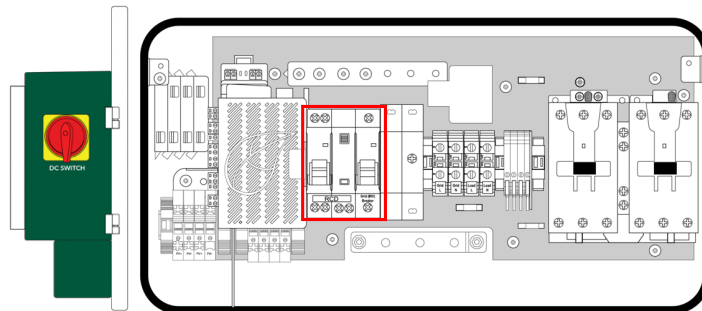

5. Turn on the RCD and GRID (INV) breakers in the Link.
6. Turn on AC power to the Link at the service disconnect.
7. Ensure the E-Stop button (if used) is not in the stopped position.

## Commissioning and Tigo App

The Tigo Energy Intelligence platform and mobile app enables easy system commissioning and provides comprehensive ongoing visibility into system and module performance. Please refer for detailed information.



The Tigo EI app for Android and iOS mobile devices enables fast system commissioning and provides comprehensive visibility into system and module performance. Scan one of these QR codes to download the app. To run the Tigo EI app and configure the GO Battery, first ensure Bluetooth is enabled on your mobile device. Do not try to select your system using your mobile device's Bluetooth settings. The EI app will automatically connect to your system's Bluetooth transmitter.

### Tigo ESS Operation Mode

There are three operation modes for Tigo EI solution, self-consumption, backup, and time-of-use. Users can configure them either in Tigo EI App or Tigo EI web portal. The steps are as below:

Step 1: Click the setting icon  at the lower right corner.

Step 2: Click Energy/Battery Management

Step 3: In the “Select Mode” window, choose one of the operation mode, then click “Apply”.

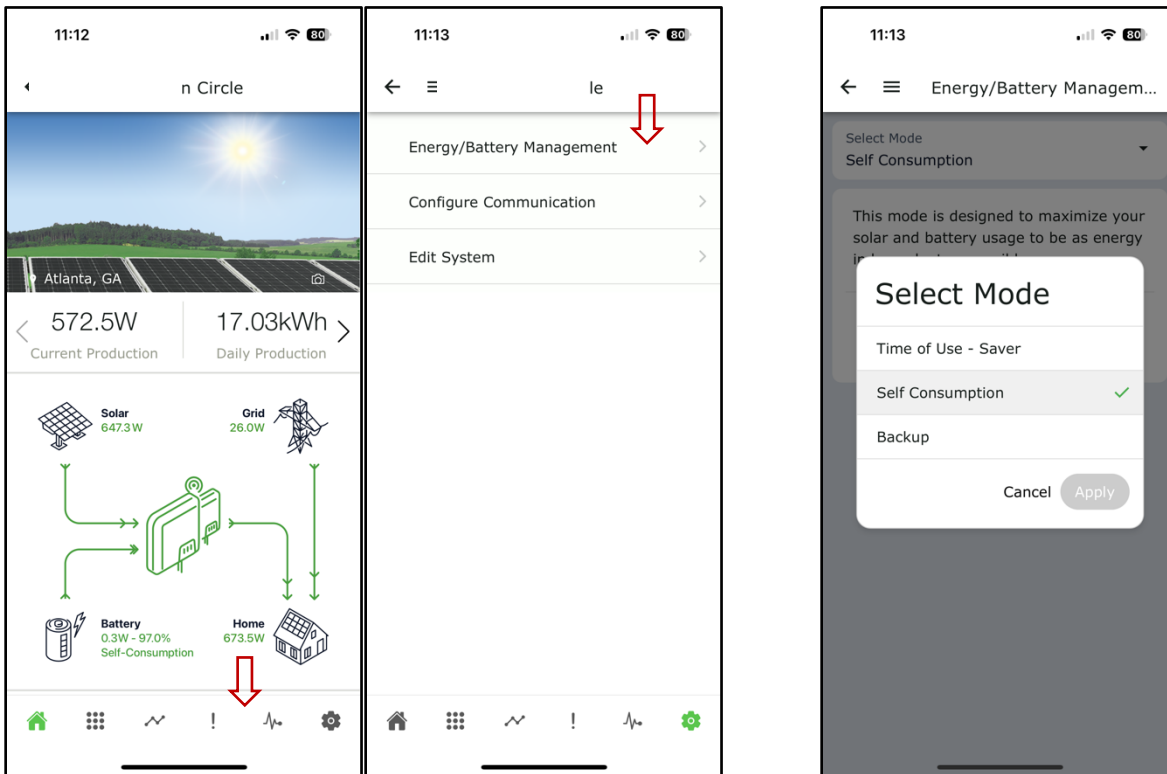

### Self-Consumption

Self-consumption is designed to maximize your solar and Battery usage to be energy independent as much as possible.

In this mode, when PV is available, it first powers the loads, then charges the Battery with any surplus, and finally exports to the grid after Battery reach its limit (either full SOC or max charging rate). If the zero-export limit is enabled, no power is fed back to the grid.

When PV is insufficient, the Battery powers the loads until it reaches the level of reserved energy for outage (set in Tigo App by user) or reach max discharge rate. Once the Battery reaches this limit, the grid supplies power to the loads. Grid power will not charge the Battery if the Battery SOC is higher than the level of reserved energy for outage.

**User setting:**

The only parameter users need to configure is the “Reserved energy for outage,” which is the SOC level they wish to reserve for unexpected power outages.

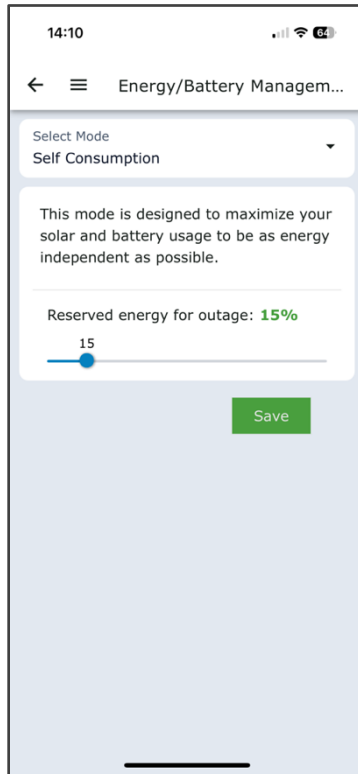
**Backup**

Users select this mode to prepare for anticipated power outages by charging the Battery to 100% SOC. Once fully charged, the Battery maintains 100% SOC and remains on standby until grid power is lost. This mode is commonly used in areas prone to frequent outages, where the ESS functions as a UPS to ensure uninterrupted power supply.

In this mode, PV power, and AC power (if PV is insufficient) to support the load and max Battery charging until the limit is reached (either full SOC or max charging power). The Battery does not discharge to support the load while the grid is available. Instead, it maintains 100% SOC, ready for a power outage.

**User setting:**

No user settings are required for the backup mode. The Tigo ESS defaults the maximum Battery SOC to 100%, ensuring the Battery is charged to full capacity as quickly as possible and remains on hot standby.

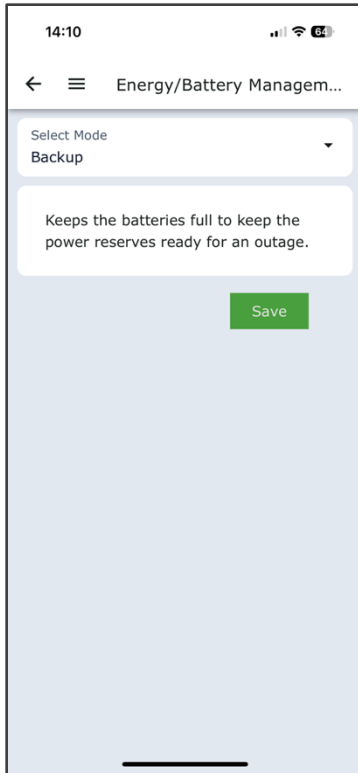

### *Time of Use – Saver*

Time-of-Use mode is designed to avoid using power from grid during peak times when the electricity charge is high. The ESS behaves differently during peak times and off-peak times.

#### *1. Peak Time Periods:*

During these periods, PV power is prioritized to support the load, and the Battery is discharged as needed to minimize grid usage, avoiding high-tariff periods. Grid power is only drawn if the Battery SOC falls below the level of “reserved energy for outage” or its max discharge rate cannot support all the loads.

#### *2. Off-Peak Periods:*

During off-peak times, PV power is prioritized to support the load, and extra PV will be used for charging the Battery. Battery will not discharge to support the load. Grid power will be drawn if PV is insufficient to support the load, but grid power will not charge the Battery unless the “Charge Battery From Grid” is enabled.

#### *3. Charge Battery From Grid*

Once this option is enabled, it allows to charge Battery to 100% with energy from the grid during a specified time window.

#### *4. Force Battery Discharge*

Forces the Battery to discharge at full power during a specified time window. Battery power and PV support the load first, with any excess exported to the grid. This option is typically used when utilities offer high feed-in tariffs as rewards.

**User setting:**

Users need to configure the following settings for this mode:

- Peak time window. Click the “+” button to add a second peak time. The off-peak time is beyond peak time.
- Reserved energy for outage.
- Optional “Charge Battery from grid” and “Force Battery discharge” time window.

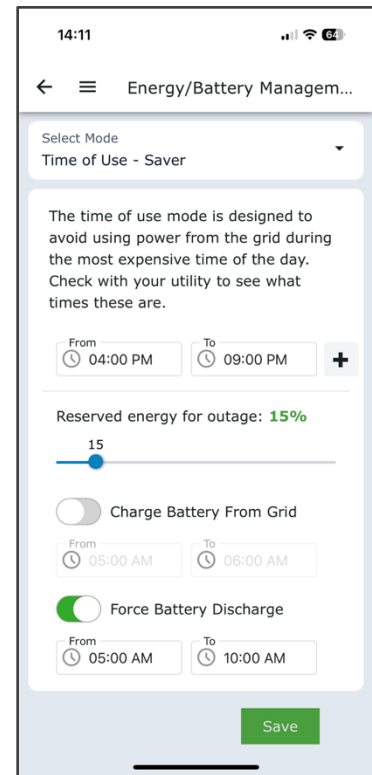
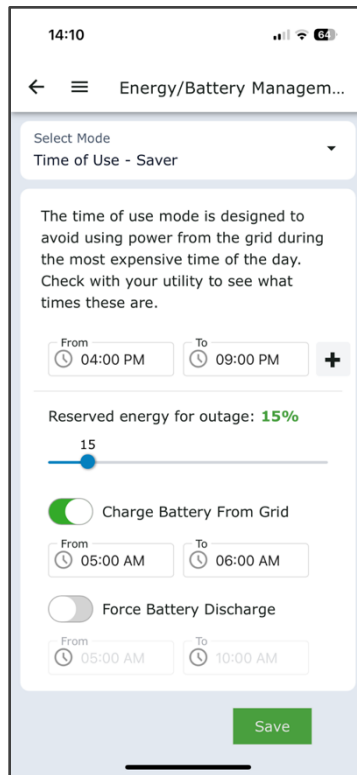
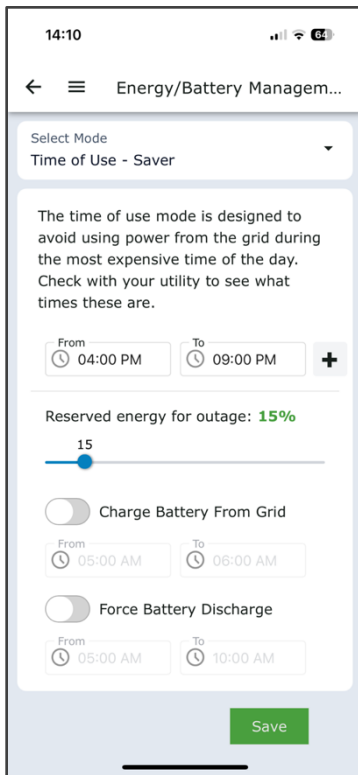

## Dynamic Rate

Dynamic Rate mode is designed to optimize the behavior of the Tigo GO Optimized ESS in presence of electricity contract based on dynamic electricity rates (or tariffs).

In several countries, electricity providers offer dynamic energy tariffs that change every day: hourly, half-hourly or different time period based on supply and demand on the wholesale electricity market.

The wholesale rates shown in Tigo EI do not include additional charges and taxes but are useful to identify cheap or expensive electricity periods; the final price trend for the system owner will be like the wholesale one.

With dynamic rates, Peak periods and Off-Peak periods change every day.

Tigo GO Optimized ESS can automatically recognize “Peak periods” (expensive periods) and “Off-Peak periods” (cheap periods) and behave accordingly every day.

Dynamic rates are specific and change per country. Tigo GO Optimized ESS detects the wholesale tariffs for the specific country of installation of the system and operates accordingly.

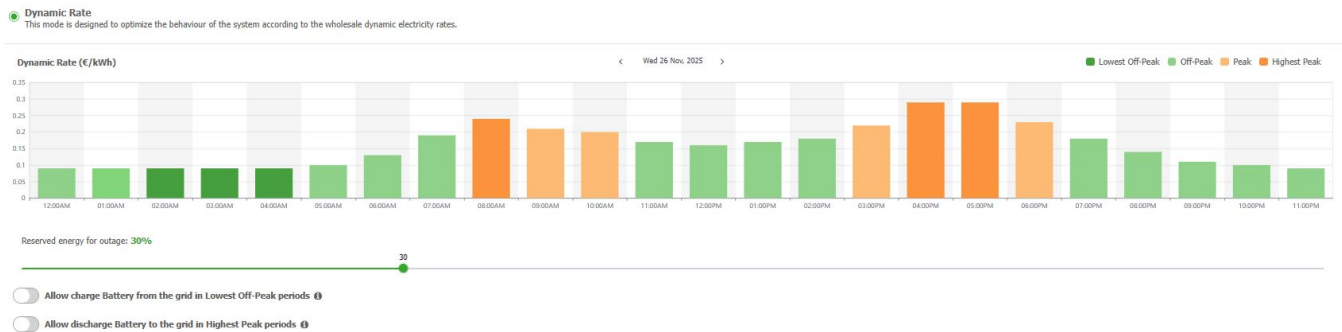

### 1. Peak Time Periods:

During Peak Time periods, PV power is prioritized to support the load, and the Battery is discharged as needed to minimize grid usage, avoiding high-tariff periods. Grid power is only drawn if the Battery SOC falls below the level of “reserved energy for outage” or its max discharge rate cannot support all the loads.

Among the Peak Periods, Tigo EI identifies the “Highest Peak” periods (most expensive hours of the day).

### 2. Off-Peak Time Periods:

During Off-Peak Time periods, PV power is prioritized to support the load, and extra PV will be used for charging the Battery. Battery will not discharge to support the load. Grid power will be drawn if PV is insufficient to support the load, but grid power will not charge the Battery unless the “Charge Battery From Grid” is enabled.

Among the Off-Peak Periods, Tigo EI identifies the “Lowest Off-Peak” periods (cheapest hours of the day).

### 3. Allow *Charge Battery From Grid*

This option is disabled by default; once this option is enabled, it allows to charge Battery to 100% with energy from the grid during the self-recognized “Lowest Off-Peak” periods.

### 4. Allow *Discharge Battery to the Grid*

This option is disabled by default; once this option is enabled, Battery is allowed to discharge at full power during the self-recognized “Highest Peak” periods. Battery power and PV support the load first, with any excess exported to the grid. This option is typically used when utilities offer high feed-in tariffs as rewards.

#### User setting:

- “Reserved energy for outage”: select a specific Battery SOC percentage (optional)
- Optional enable of “Allow Charge Battery from grid in Lowest Off-Peak periods” toggle. Users do not need to select the specific time periods, Tigo EI automatically will do it during the identified Lowest Off-Peak periods.
- Optional enable of “Allow Discharge Battery to the grid in Highest Peak periods.” Users do not need to specify the time periods, Tigo EI automatically will do it during the identified Highest Peak periods.
- Two toggles can be enabled/disabled independently.

Reserved energy for outage: 20%

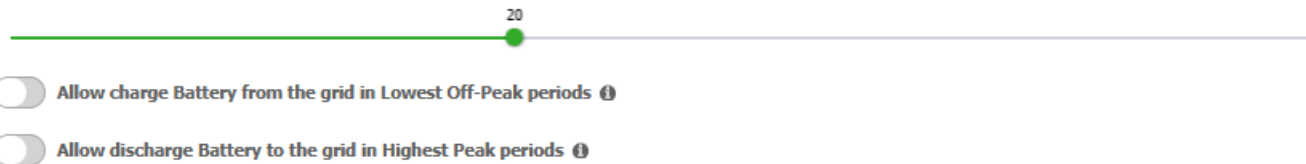

Dynamic Rate mode is available in specific countries. Refer also to Tigo support articles in the resource center for latest updates and country availability.

## Reference

This section includes the following topics:

- Torque Table
- Status LCD
- Power Off the System
- Decommissioning
- Maintenance
- Error Codes

## Torque Table

Tighten connections to the following specifications:

Link ground	2.5Nm
Link GRID (INV)	1.5Nm
TAP	0.4Nm
Link EPS (INV)	1.5Nm
Link grounding bus	1.5Nm
Link PV	1.5Nm

## GO Logo Operation

Battery Status	"GO"		Ring	
	Color	Action	Color	Action
Idle/Standby	Blue	Solid	Blue	Solid Blue indicates SOC
Charging	Green	Solid	Green	LEDs turn on consecutively from bottom up to SOC
Discharging	Green	Solid	Blue	LEDs turn on consecutively from down up to SOC
Upgrading	Yellow	Blink	N/A	Off
System Fault	Red	Solid	N/A	Off
System Off	N/A	Off	N/A	Off

## Status LCD

The front of the Inverter includes LED indicators to monitor system status.



Do not use the Inverter LCD display to make system changes other than commissioning. Perform all operational changes with the Tigo EI mobile app.

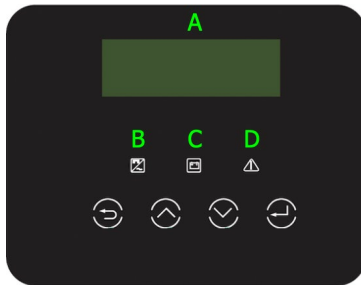

<b>A</b>	LCD screen	Inverter error code display.
<b>B</b>	Blue LED	Off: fault state. Solid: normal state or in EPS mode. Flashing: checking state or the system switch is off.
<b>C</b>	Green LED	Off: Battery is not communicating with the Inverter. Solid: Battery communication is normal. Flashing: Battery communication is normal and idle.
<b>D</b>	Red LED	Off: operation is normal. Solid: fault state.

## Maintenance

A qualified electrician or solar-installation service technician must evaluate any operational problems or external damage. In addition:

- Clean surfaces with damp cloth. Never use solvents or abrasives.
- Maintain proper clearances around all enclosures to ensure proper air circulation.
- Check enclosures quarterly and remove any insects and rodent nests. This will ensure proper ventilation and maximum performance.

## Power Off the System



Wait five minutes after complete system shutdown before servicing the Battery.

To power off the system:

1. Turn off the AC disconnect switch between the Inverter and the service entrance.
2. Turn off the RCD and GRID (INV) breakers in the Link.
3. Turn off the DC breaker on the left side of the Link.
4. Press the button on the BMS to turn off, then switch to OFF

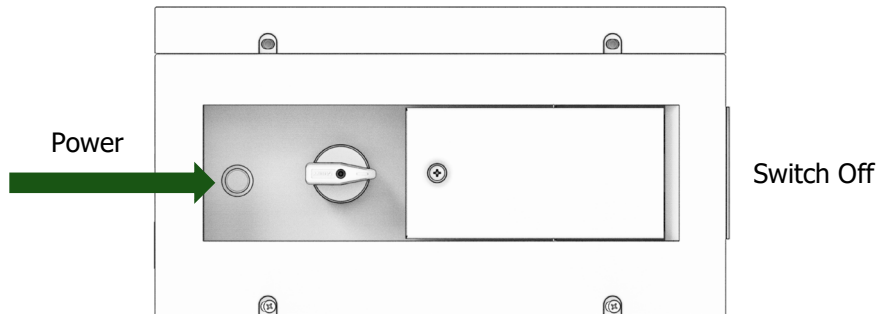

## Error Codes



Qualified personnel must only perform troubleshooting.

Error codes appear on Inverter and Battery displays. The Inverter LCD display also includes LEDs that signal various conditions. Refer to the *Status LCD* topic for details.

The Tigo EI app chat function enables real-time help from a Tigo service agent for the issue you are experiencing. For error codes not listed or if any problem persists, [contact Tigo support](#).

### *Inverter Codes*

Code	Fault	Tigo Fault	What To Do
IE 001	TZ protect fault	Overcurrent fault	1) Wait to see if the system returns to normal. 2) Disconnect PV+/PV- and batteries, then reconnect.
IE 002	Grid lost fault	Grid lost fault	Wait to see if power returns and the system reconnects. Then check if the grid voltage is within normal range.
IE 003	Grid volt fault	Grid voltage fault	Wait to see if power returns and the system reconnects. Then check if the grid voltage is within normal range.
IE 004	Grid freq fault	Grid frequency fault	Wait to see if power returns and the system reconnects.
IE 005	PV volt fault	Pv voltage fault	Check the output voltage of the PV modules. If string voltage is greater than 600V <sub>DC</sub> , shut down the system and troubleshoot the strings.

Code	Fault	Tigo Fault	What To Do
IE 006	Bus volt fault	Bus voltage fault	Restart the Inverter and check if $V_{OC}$ is in the normal range. If string voltage is greater than $600V_{DC}$ , shut down the system and troubleshoot the strings.
IE 007	Bat volt fault	Battery voltage fault	Check if Battery input voltage is in normal range.
IE 008	AC10M volt fault	Grid voltage fault	The system should return to normal when the grid returns to normal.
IE 009	DCI OCP fault	DCI overcurrent protection fault	Wait for the system to return to normal.
IE 011	SW OCP fault	Software detection of overcurrent fault	Wait for the system to return to normal. If it does not: 1. Shut down photovoltaic, Battery and grid connections. 2. Restart the Inverter.
IE 012	RC OCP fault	Overcurrent protection fault	Check DC input and AC output impedance and wait for the system to return to normal.
IE 013	Isolation fault	Insulation fault	1. Wait for the system to return to normal. 2. Check wire insulation for damage.
IE 014	Temp over fault	Temperature fault	Check if ambient temperature exceeds the equipment limits. If exceeded, move or shade equipment. See installation requirements.
IE 015	Bat Con Dir fault	Battery connection fault	Check for reversed Battery input lines.
IE 017	EPS (off-grid) overload fault	EPS (off-grid) overload fault	Shutdown the device drawing excessive power and restart the Inverter.
IE 018	Overload fault	On-grid mode overload fault	Shutdown the device drawing excessive power and restart the Inverter.
IE 019	PV conn dir fault	PV direction fault	Check if PV input lines are reversed.
IE 020	BatPowerLow	Battery power low fault	1. Shutdown the device drawing excessive power and restart the Inverter. 2. Charge the Battery to a level higher than the minimum protection capacity or protection voltage.
IE 021	Low temp	Low temperature fault	Check if the ambient temperature is too low.
IE 023	Charger relay fault	Charge relay fault	Restart the Inverter.
IE 024	BMS lost	Battery communication fault	Check communication cables between the Battery and the Inverter are properly connected.
IE 025	Inter comms fault	Internal communication fault	Shut down the PV array, Battery, and grid and reconnect the system.
IE 026	Fan fault	Fan fault	Check for foreign matters that could cause the fan to function improperly.

Code	Fault	Tigo Fault	What To Do
IE 027	Grounding relay fault	EPS (off-grid) grounding relay fault	Restart the Inverter.
IE 028	Internal error	Internal error	Shut down the PV array, Battery, and grid and reconnect the system.
IE 029	RCD fault	Residual current device fault	1. Check DC input and AC output impedance. 2. Disconnect and reconnect PV+/PV- and batteries.
IE 030	EPS (off-grid) relay fault	EPS (off-grid) relay failure	Disconnect and reconnect PV+/PV-, grid, and batteries.
IE 031	Grid relay fault	Electrical relay failure	Disconnect and reconnect PV+/PV-, grid, and batteries.

### Battery Codes

Code	Fault	Tigo Fault	What to Do
BE 11	BMS Circuit Fault	Battery – circuit failure	Restart the Battery.
BE 12	BMS ISO Fault	Battery – insulation failure	Check that the Battery is properly ground and restart the Battery.
BE 14	BMS_TempSen_Fault	Battery – temperature sensor failure	Restart the Battery.
BE 17	BMS_Type_Unmatch	Battery – type failure	Use the Tigo EI app to upgrade the BMS software.
BE 18	BMS_Ver_Unmatch	Battery – version mismatch failure	Use the Tigo EI app to upgrade the BMS software.
BE 19	BMS_MFR_Unmatch	Battery – manufacturer not matching fault	Use the Tigo EI app to upgrade the BMS software.
BE 20	BMS_SW_Unmatch	Battery – hardware and software mismatch failure	Use the Tigo EI app to upgrade the BMS software.
BE 21	BMS_M&S_Unmatch	Battery – master slave control mismatch	Use the Tigo EI app to upgrade the BMS software.
BE 22	BMS_CR_NORespond	Battery – charging request not responding	Use the Tigo EI app to upgrade the BMS software.
BE 23	BMS_SW_Protect	Battery – slave software protection failure	Wait for the Tigo EI app to finish updating BMS firmware.
BE 30	BMS_AirSwitch_Fault	Battery – air switch failure	If the Battery breaker is ON, contact Tigo support.

## Customer Support

---

The Tigo support team is available by:

- Chatting with a tech through the Tigo EI app.
- Submitting a ticket from the Tigo EI app.
- Submitting a ticket through the [Tigo Help Center](#).
- Call +39 055 1987 0059

Support hours are Monday – Friday, 9am – 1pm and 2pm – 6pm CET.

When you contact Tigo support for installation or operational assistance:

- If the system is commissioned and connected to the internet, Tigo will have component-level data to help understand and resolve the issue. If you have not yet commissioned the system, you will need to know your System ID as well as serial and model numbers for the Inverter, Battery, and MLPE components relevant to your issue.

Support will need:

- A description and history of the problem.
- Any relevant error codes.
- A procedure for reproducing the problem, if possible.
- Grid and DC input voltage (for Inverters).
- Ambient weather conditions.
- If module-level monitoring was not installed or was improperly mapped, you may be asked for the module manufacturer, model, wattage,  $V_{OC}$ ,  $V_{MP}$ ,  $I_{MP}$ , and the number of modules in each string.

## Specifications

Download comprehensive specifications for all Tigo products from the Tigoenergy.com [Downloads](#) ([www.tigoenergy.com/downloads](http://www.tigoenergy.com/downloads)) page.

## Warranty

Download comprehensive warranty information from the Tigoenergy.com [Downloads](#) ([www.tigoenergy.com/downloads](http://www.tigoenergy.com/downloads)) page.