

**NORELL**®

Imagination • Innovation • Results  
In Science & in Business™

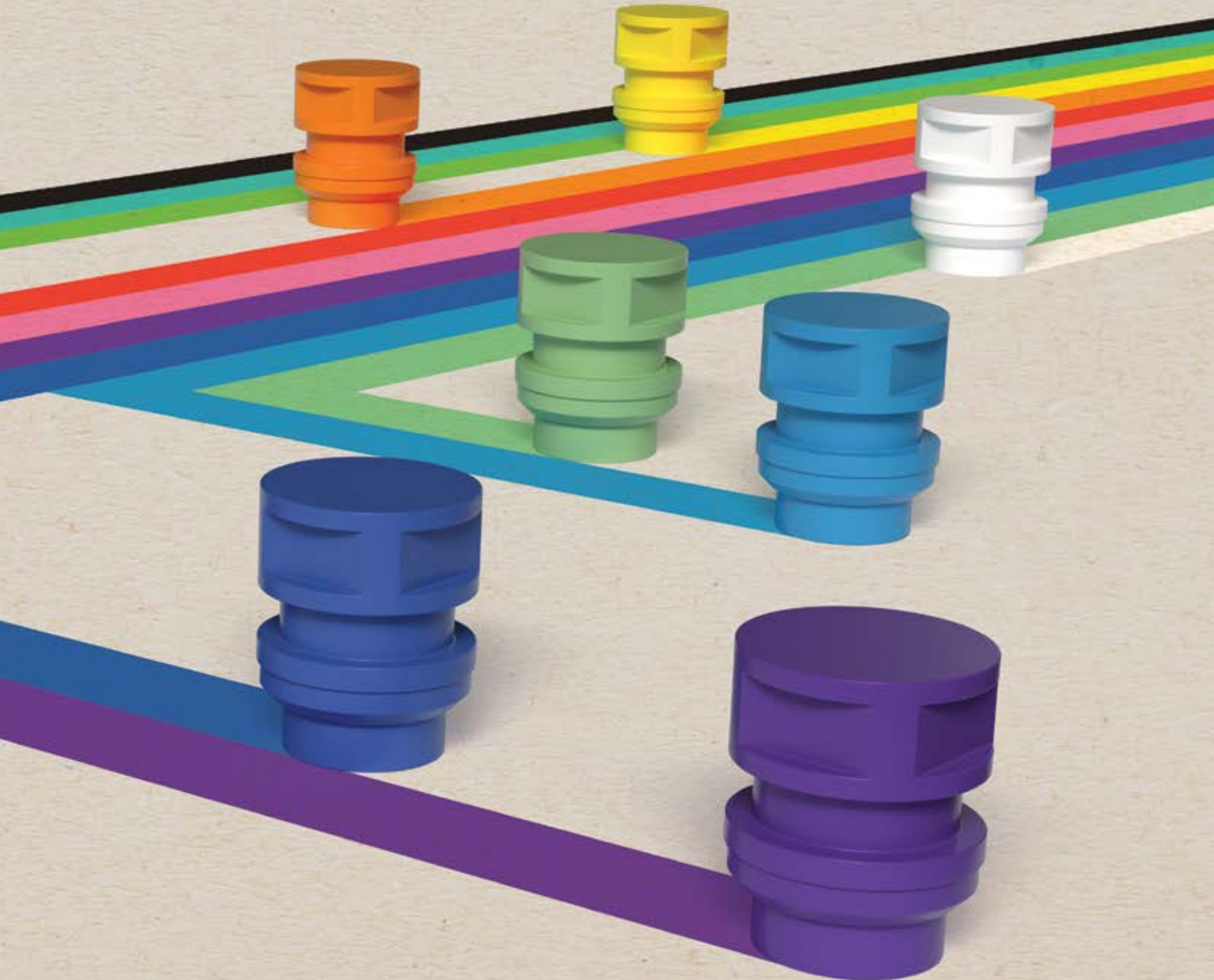

**VALVED NMR FOR REDUCED  
& INTERMEDIATE PRESSURE  
NOW COMPATIBLE WITH  
AUTOMATED SAMPLING**

133 mm NMR Sample Tube Lengths  
in 500 MHz & 600 MHz

VALVED NMR FOR AUTOMATED SYSTEMS  
**NOW AVAILABLE!**

FROM

**NORELL**<sup>®</sup>

PAGE 26

# TABLE OF CONTENTS

## Secure Series NMR Tubes

Secure Series™/NorLoc™ II.....	4
Secure 55 Series™ 5 mm.....	5
Secure 33 Series™ 5 mm & 3 mm.....	6-7

## Select Series NMR Tubes

10 mm Select Series™.....	8
5 mm Select Series™.....	8
3 mm & 4 mm Select Series™.....	9
5 mm & 3 mm NMR Sample Tubes for Ceramic Turbines.....	10-11

## Standard Series NMR Tubes

5 mm Standard Series™.....	12-13
10 mm Standard Series™.....	13

## Special Purpose Tubes

Ultra-Thin Series NMR Sample Tubes.....	14-16
Sample Vault™ NMR Sample Tubes & Caps.....	18-23
Sample Vault™ NMR Sample Tube Rack.....	18
Closures for Open Port Caps.....	19
Quartz NMR Tubes.....	24-25
Quartz EPR Tubes.....	25
Valved NMR Tubes for Reduced Pressure.....	26-29
Valved NMR Tubes for Intermediate Pressure.....	30-34
Valved NMR Tubes for High Pressure.....	36-39
Screw-Cap NMR Tubes.....	40
Screw Cap NMR Tube Caps.....	40
Bruker Microbore Tubes.....	41
High-Throughput NMR Tubes.....	41
Amberized NMR Tubes.....	42
Constricted NMR Tubes.....	42
Heavy/Medium Wall NMR Tubes.....	43
Bruker Match™ NMR Tubes & Tube Caps.....	44
Tapered Fluoropolymer Caps for Bruker Match™.....	45

## Fluoropolymer Tubing

Thin-Wall Transparent Fluoropolymer FEP Tubing.....	46
Fluoropolymer PTFE Tubing.....	47
Fluoropolymer PVDF Tubing.....	48-49
Fluoropolymer FEP Tubing.....	50-51
Fluoropolymer PFA Tubing.....	52-53

## Accessories

Fluoropolymer NMR Tube Caps.....	54
Permanent Markers.....	54
Pasteur Pipettes.....	55
Optimizer Inserts™ for 5 mm Turbines.....	56-57
PEEK Optimizer Inserts™ for 5 mm Turbines.....	58-59
Toroids.....	60
Spinner Brushes.....	60
Fluoropolymer NMR Tube Liners.....	61
Fluoropolymer Liner Tube Kits.....	61
3 mm & 5 mm NMR Tube Brush.....	62
NorLoc™ Cap Tube Rack.....	62
NMR Tube Cleaner, 5 Position.....	63
Tube Washing Unit.....	63
NorLoc™ II 5 mm & 3 mm Caps.....	4, 64-67
Economy NMR Tube Caps.....	68
PTFE Syringe Tubing.....	69
Cuvettes.....	70
Fluoropolymer Column Packing.....	70
Coaxial Inserts for NMR Tubes.....	71
Polypropylene Syringes.....	71
5 mm & 10 mm NMR Tube Septa.....	72
Silicone Rubber Stoppers.....	73
5 mm Biopolymer Tube Carrier from Norell®.....	74
Tube Safe Valved NMR Tube Carrier from Norell®.....	74

## Spinner Turbine Maintenance Guide.....

## Index.....

## Notes.....

MATCH™ is a trademark of Bruker BioSpin GmbH. • PYREX® is a registered trademark of Corning, Inc. DURAN® is a registered trademark of The SCHOTT-Group. • KYNAR® & KYNAR FLEX® are registered trademarks of Atofina Chemicals, Inc. • Protelyte® is a registered trademark of Hamilton Company. SUPRASIL® is a registered trademark of Heraeus Optics, LLC.

# ORDERING & GENERAL INFORMATION

## Customer Inquiries

Phone (International).....828.584.2600

Fax (International).....828.584.2604

## E-mail

Technical Service.....technicalservice@nmrtubes.com

Customer Service.....customerservice@nmrtubes.com

Sales.....sales@nmrtubes.com

## Placing an Order

Our Customer Service Department is open from 7:30 A.M. to 4:00 P.M. Eastern Time. Call us at 1.828.584.2600. Orders may be placed by FAX at 1.828.584.2604 24 hours a day or at our online store at nmrtubes.com. Please help us expedite shipment of your order by including the following information:

- Purchase Order Number
- Your name and phone number
- Shipping address
- User name and phone number
- Billing address
- Special shipping/packing instructions
- Catalog number where applicable

## Payment Terms

Net 30 days from invoice date with prior credit approval. Past due invoices will be subject to a 1.5% per month service charge; 18% per annum. We reserve the right to request payment in advance or COD terms on initial orders. We also accept Visa, MasterCard and American Express.



## **FOB Point**

*Morganton, NC 28655 USA*

Any damage to the package or product in transit is the buyer's responsibility to adjust with the carrier. Shipping and handling charges will be added to invoices unless collect shipment is requested. Handling charges still apply.

## **Method of Shipment**

Whenever possible, we will ship by the method specified in your order. However, we reserve the right to change the method specified. Within the continental United States, most shipments are made by United Parcel Service.

## **Prices**

Prices are subject to change without notice. The inventory of some products listed may become depleted. Replacement of stock may be subject to minimum order sizes. You may check stock and confirm prices by contacting Norell, Inc. Customer Service at **1.828.584.2600**.

## **Returns**

Returns may be made within 30 days of shipment with the prior approval of Norell, Inc. We reserve the right to impose restocking charges when a return is at the sole option of the buyer. The buyer is responsible for approving the quality and quantity of any product within the 30-day period stated above. If an error by Norell, Inc. results in an incorrect or duplicate shipment, a replacement will be sent or the appropriate credit allowed. We request return of the original product. Product returns must reference the original purchase order number, Norell, Inc. invoice number, the date Norell, Inc. authorized the return, and the name of the authorizing employee.

## **Warranty**

We claim only that Norell, Inc. products are as described upon shipment. Norell, Inc. makes no other warranty, expressed or implied, with respect to our products, including any warranty of merchantability or fitness for any particular purpose. Norell's maximum liability for any reason shall be replacement of product or refund of the purchase price.

# SECURE SERIES™ NMR SAMPLE TUBES

U.S. PATENT NO. D794,820 & 8,054,080

## SECURE SERIES™

The NORELL® Secure Series™ line of 5 mm and 3 mm O.D. NMR tubes with NORELL® NorLoc II Security Cap™ delivers proven sample security and containment for your most critical applications.

The Secure Series™ NMR tubes incorporate patented design elements that provide superior sample containment and isolation, protecting the integrity of precious or critical NMR samples while ensuring secure retention of the NMR tube in the spinner turbine. Available in standard and **Ultra-Thin** wall configurations.

### Security Band

- A patented Security Band™ that engages and locks into the NorLoc II Security Cap™, securely joining the cap to the NMR tube.
- The Security Band™ edge also serves as a stop position for partial, temporary cap placement, allowing quick and easy access to the NMR tube.
- A patented proprietary surface treatment with a unique textured surface ensures precise and positive retention in Bruker, Agilent/Varian, and Jeol spinner turbines.
- A patented marking and label area that also functions as a clear visual indicator, defining the limit for full and complete closure with the NorLoc II Security Cap™.

- The Secure Series™ NMR tubes are available in two types: the Secure 33 Series™ and the Secure 55 Series™, both offered in 178 mm and 203 mm lengths.

### Proprietary Surface Treatment for Secure Turbine Retention

- The Secure 33 Series™ NMR tubes are made from ASTM Type I Class A borosilicate glass (Pyrex® 7740 or equivalent) and have comparable glass properties to the Norell Select Series™ NMR tubes.
- The Secure 55 Series™ NMR tubes are made from ASTM Type I Class B borosilicate glass (N-51A or equivalent) and have comparable glass properties to the Norell Standard Series™ NMR tubes.
- The Secure Series™ NMR tubes remain completely compatible with standard, classic NMR tube caps in both 5 mm and 3 mm sizes.

**See Page 64 for more information about NorLoc Generation II Caps.**

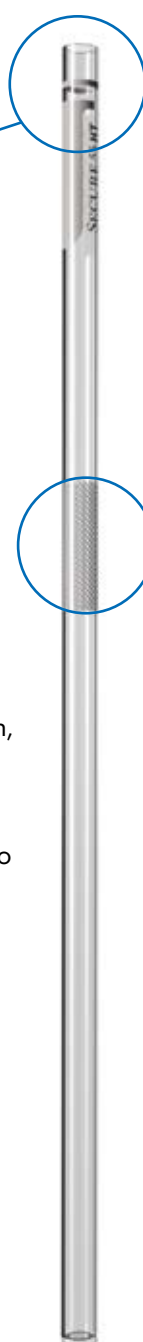

## The Secure 55 Series™ NMR Sample Tubes for Routine NMR

The Secure 55 Series™ NMR tubes are made from ASTM Type I Class B borosilicate glass ("high expansion" borosilicate glass such as Kimble N-51A or equivalent) and parallel the properties of the Standard Series™ NMR tubes from Norell. These tubes are ideal for near room temperature analyses of routine samples exposed only to slight thermal gradients. Due to the larger coefficient of thermal expansion of this glass type, we do not recommend fusing these NMR tubes to glass vacuum manifolds or other glass laboratory apparatus, as these are usually constructed from low expansion borosilicate glass such as Pyrex® 7740. The dissimilar thermal expansion rates of the two glass types can result in cracking or breaking of the glass-to-glass seal.

### 5 mm Ultra-Precision, High-Precision & Precision NMR Sample Tubes

Item No.	Spinner Turbine	MHz	O.D. (mm)	I.D. (mm)	Concentricity (mm)	Camber ±(mm)	Length (mm)	Packed In Lots of
S55-1000-050-1780	Bruker	1,000	4.97 ± 0.004	4.20 ± 0.006	0.003	0.004	178	5
S55-1000-050-2030	Agilent/Varian	1,000	4.97 ± 0.004	4.20 ± 0.006	0.003	0.004	203	5
S55-0800-050-1780	Bruker	800	4.97 ± 0.005	4.20 ± 0.012	0.004	0.005	178	5
S55-0800-050-2030	Agilent/Varian	800	4.97 ± 0.005	4.20 ± 0.012	0.004	0.005	203	5
S55-0600-050-1780	Bruker	600	4.97 ± 0.006	4.20 ± 0.012	0.004	0.006	178	5
S55-0600-050-2030	Agilent/Varian	600	4.97 ± 0.006	4.20 ± 0.012	0.004	0.006	203	5
S55-0500-050-1780	Bruker	500	4.97 ± 0.013	4.20 ± 0.025	0.005	0.013	178	5
S55-0500-050-2030	Agilent/Varian	500	4.97 ± 0.013	4.20 ± 0.025	0.005	0.013	203	5
S55-0400-050-1780	Bruker	400	4.97 ± 0.013	4.20 ± 0.025	0.007	0.019	178	5
S55-0400-050-2030	Agilent/Varian	400	4.97 ± 0.013	4.20 ± 0.025	0.007	0.019	203	5
S55-0300-050-1780	Bruker	300	4.97 ± 0.025	4.20 ± 0.025	0.007	0.025	178	25
S55-0300-050-2030	Agilent/Varian	300	4.97 ± 0.025	4.20 ± 0.025	0.007	0.025	203	25
S55-00GS-050-1780	Bruker	300	4.97 ± 0.025	4.20 ± 0.025	0.010	0.038	178	25
S55-00GS-050-2030	Agilent/Varian	300	4.97 ± 0.025	4.20 ± 0.025	0.010	0.038	203	25
S55-0200-050-1780	Bruker	200	4.97 ± 0.030	4.20 ± 0.030	0.010	0.040	178	25
S55-0200-050-2030	Agilent/Varian	200	4.97 ± 0.030	4.20 ± 0.030	0.010	0.040	203	25

### 5 mm Economy High-Throughput NMR Sample Tubes

Item No.	Spinner Turbine	MHz	O.D. (mm)	I.D. (mm)	Concentricity (mm)	Camber ±(mm)	Length (mm)	Packed In Lots of
S55-OHTP-050-1780	Bruker	HT <sup>PLUS</sup>	4.97 ± 0.050	4.20 ± 0.050	0.020	0.070	178	50
S55-OHTP-050-2030	Agilent/Varian	HT <sup>PLUS</sup>	4.97 ± 0.050	4.20 ± 0.050	0.020	0.070	203	50
S55-00HT-050-1780	Bruker	HT	4.97 ± 0.050	4.20 ± 0.050	0.025	0.075	178	100
S55-00HT-050-2030	Agilent/Varian	HT	4.97 ± 0.050	4.20 ± 0.050	0.025	0.075	203	100

Secure Series™ is now available in **Ultra-Thin** wall. Call **1-800-828-584-2600** or visit [www.nmrtubes.com/nmr-epr-tubes/secure-series](http://www.nmrtubes.com/nmr-epr-tubes/secure-series) to access our custom quote form.

NMR tubes are manufactured with round bottoms and are available with flat bottoms upon request.  
We manufacture all NMR tubes in any length upon request.

# SECURE SERIES™ NMR SAMPLE TUBES

## The Secure 33 Series™ NMR Sample Tubes for High Resolution NMR

The Secure 33 Series™ NMR tubes are made from ASTM Type I Class A borosilicate glass ("low expansion" borosilicate glass such as Corning Pyrex® 7740 or equivalent) and match the properties of the Select Series™ NMR tubes from Norell. Because of the low coefficient of thermal expansion, Secure 33 Series™ NMR tubes show a high degree of thermal shock resistance, a necessary attribute to prevent breakage when large temperature variations are expected in variable temperature studies, degassing samples through freeze-pump-thaw cycles, and similar applications.

### 5 mm Ultra-Precision NMR Sample Tubes

Item No.	Spinner Turbine	MHz	O.D. (mm)	I.D. (mm)	Concentricity (mm)	Camber ±(mm)	Length (mm)	Packed In Lots of
S33-1000-050-1780	Bruker	1000	4.97 ± 0.003	4.20 ± 0.006	0.0018	0.0027	178	5
S33-1000-050-2030	Agilent/Varian	1000	4.97 ± 0.003	4.20 ± 0.006	0.0018	0.0027	203	5
S33-0900-050-1780	Bruker	900	4.97 ± 0.004	4.20 ± 0.006	0.0020	0.0030	178	5
S33-0900-050-2030	Agilent/Varian	900	4.97 ± 0.004	4.20 ± 0.006	0.0020	0.0030	203	5
S33-0800-050-1780	Bruker	800	4.97 ± 0.005	4.20 ± 0.012	0.0025	0.0038	178	5
S33-0800-050-2030	Agilent/Varian	800	4.97 ± 0.005	4.20 ± 0.012	0.0025	0.0038	203	5
S33-0600-050-1780	Bruker	600	4.97 ± 0.006	4.20 ± 0.012	0.0040	0.0060	178	5
S33-0600-050-2030	Agilent/Varian	600	4.97 ± 0.006	4.20 ± 0.012	0.0040	0.0060	203	5
S33-0500-050-1780	Bruker	500	4.97 ± 0.013	4.20 ± 0.025	0.0050	0.0130	178	5
S33-0500-050-2030	Agilent/Varian	500	4.97 ± 0.013	4.20 ± 0.025	0.0050	0.0130	203	5
S33-0400-050-1780	Bruker	400	4.97 ± 0.013	4.20 ± 0.025	0.0070	0.0190	178	5
S33-0400-050-2030	Agilent/Varian	400	4.97 ± 0.013	4.20 ± 0.025	0.0070	0.0190	203	5
S33-0300-050-1780	Bruker	300	4.97 ± 0.025	4.20 ± 0.025	0.0070	0.0250	178	5
S33-0300-050-2030	Agilent/Varian	300	4.97 ± 0.025	4.20 ± 0.025	0.0070	0.0250	203	5
S33-0200-050-1780	Bruker	200	4.97 ± 0.030	4.20 ± 0.030	0.0090	0.0350	178	5
S33-0200-050-2030	Agilent/Varian	200	4.97 ± 0.030	4.20 ± 0.030	0.0090	0.0350	203	5

**SECURE SERIES™**





### Secure Series 3 mm Ultra-Precision NMR Sample Tubes

Item No.	Spinner Turbine	MHz	O.D. (mm)	I.D. (mm)	Concentricity (mm)	Camber ±(mm)	Length (mm)	Packed In Lots of
S33-1000-030-1780	Bruker	1000	2.99 ± 0.003	2.41 ± 0.006	0.0018	0.0027	178	5
S33-1000-030-2030	Agilent/Varian	1000	2.99 ± 0.003	2.41 ± 0.006	0.0018	0.0027	203	5
S33-0900-030-1780	Bruker	900	2.99 ± 0.004	2.41 ± 0.006	0.0020	0.0030	178	5
S33-0900-030-2030	Agilent/Varian	900	2.99 ± 0.004	2.41 ± 0.006	0.0020	0.0030	203	5
S33-0800-030-1780	Bruker	800	2.99 ± 0.005	2.41 ± 0.010	0.0025	0.0038	178	5
S33-0800-030-2030	Agilent/Varian	800	2.99 ± 0.005	2.41 ± 0.010	0.0025	0.0038	203	5
S33-0600-030-1780	Bruker	600	2.99 ± 0.006	2.41 ± 0.012	0.0040	0.0060	178	5
S33-0600-030-2030	Agilent/Varian	600	2.99 ± 0.006	2.41 ± 0.012	0.0040	0.0060	203	5
S33-0500-030-1780	Bruker	500	2.99 ± 0.010	2.41 ± 0.015	0.0050	0.0130	178	5
S33-0500-030-2030	Agilent/Varian	500	2.99 ± 0.010	2.41 ± 0.015	0.0050	0.0130	203	5
S33-0400-030-1780	Bruker	400	2.99 ± 0.013	2.41 ± 0.020	0.0070	0.0190	178	5
S33-0400-030-2030	Agilent/Varian	400	2.99 ± 0.013	2.41 ± 0.020	0.0070	0.0190	203	5
S33-0300-030-1780	Bruker	300	2.99 ± 0.025	2.41 ± 0.025	0.0070	0.0250	178	5
S33-0300-030-2030	Agilent/Varian	300	2.99 ± 0.025	2.41 ± 0.025	0.0070	0.0250	203	5
S33-0200-030-1780	Bruker	200	2.99 ± 0.030	2.41 ± 0.030	0.0100	0.0380	178	5
S33-0200-030-2030	Agilent/Varian	200	2.99 ± 0.030	2.41 ± 0.030	0.0100	0.0380	203	5

### 3 mm Economy High-Throughput NMR Sample Tubes

Item No.	Spinner Turbine	MHz	O.D. (mm)	I.D. (mm)	Concentricity (mm)	Camber ±(mm)	Length (mm)	Packed In Lots of
S33-00HT-030-1780	Bruker	HT	2.99 ± 0.050	4.20 ± 0.050	0.020	0.070	178	25
S33-00HT-030-2030	Agilent/Varian	HT	2.99 ± 0.050	4.20 ± 0.050	0.025	0.075	203	25

Secure Series™ is now available in **Ultra-Thin** wall. Call **1-800-828-584-2600** or visit [www.nmrtubes.com/nmr-epr-tubes/secure-series](http://www.nmrtubes.com/nmr-epr-tubes/secure-series) to access our custom quote form.

NMR tubes are manufactured with round bottoms and are available with flat bottoms upon request.  
We manufacture all NMR tubes in any length upon request.

# SELECT SERIES™ FOR HIGH RESOLUTION NMR

## Manufactured from ASTM Type I Class A Glass, Commonly Referred to as Pyrex®

Select Series™ NMR tubes are manufactured from ASTM Type I Class A glass, commonly referred to as Pyrex® 7740 (Corning), Duran® (Schott Glass), or Kimax® KG-33 (Kimble) glass. Key properties that make this glass type desirable for NMR are its high degree of thermal shock resistance and low expansion coefficient. This allows for a greater margin of safety from breakage when used in variable temperature applications and freeze/thaw cycling, or in any other application where large temperature variations are required in the experiment. Each NMR tube is checked for concentricity and camber specifications utilizing the latest computer technology. At Norell, we have taken NMR tube manufacturing to a new level of science. Now available in **Ultra-Thin** wall.

### 10 mm Ultra-Precision NMR Sample Tubes

Item No.	MHz	O.a.D. (mm)	I.D. (mm)	Concentricity (mm)	Camber ±(mm)	Length (mm)	Packed In Lots of
S-10-600-7	600	10.00 ± 0.006	8.76 ± 0.012	0.004	0.006	178	5
S-10-600-8	600	10.00 ± 0.006	8.76 ± 0.012	0.004	0.006	203	5
S-10-500-7	500	10.00 ± 0.013	8.76 ± 0.025	0.005	0.007	178	5
S-10-500-8	500	10.00 ± 0.013	8.76 ± 0.025	0.005	0.007	203	5

### 5 mm Ultra Precision NMR Sample Tubes

Item No.	MHz	O.D. (mm)	I.D. (mm)	Concentricity (mm)	Camber ±(mm)	Length (mm)	Packed In Lots of
S-5-1000-7	1000	4.97 ± 0.003	4.20 ± 0.006	0.0018	0.0027	178	5
S-5-1000-8	1000	4.97 ± 0.003	4.20 ± 0.006	0.0018	0.0027	203	5
S-5-900-7	900	4.97 ± 0.004	4.20 ± 0.006	0.0020	0.0030	178	5
S-5-900-8	900	4.97 ± 0.004	4.20 ± 0.006	0.0020	0.0030	203	5
S-5-800-7	800	4.97 ± 0.005	4.20 ± 0.012	0.0025	0.0038	178	5
S-5-800-8	800	4.97 ± 0.005	4.20 ± 0.012	0.0025	0.0038	203	5
S-5-600-7	600	4.97 ± 0.006	4.20 ± 0.012	0.0040	0.0060	178	5
S-5-600-8	600	4.97 ± 0.006	4.20 ± 0.012	0.0040	0.0060	203	5
S-5-500-7	500	4.97 ± 0.013	4.20 ± 0.025	0.0050	0.0130	178	5
S-5-500-8	500	4.97 ± 0.013	4.20 ± 0.025	0.0050	0.0130	203	5
S-5-400-7	400	4.97 ± 0.013	4.20 ± 0.025	0.0070	0.0190	178	5
S-5-400-8	400	4.97 ± 0.013	4.20 ± 0.025	0.0070	0.0190	203	5
S-5-300-7	300	4.97 ± 0.025	4.20 ± 0.025	0.0070	0.0250	178	5
S-5-300-8	300	4.97 ± 0.025	4.20 ± 0.025	0.0070	0.0250	203	5
S-5-200-7	200	4.97 ± 0.030	4.20 ± 0.030	0.0090	0.0350	178	5
S-5-200-8	200	4.97 ± 0.030	4.20 ± 0.030	0.0090	0.0350	203	5



Select Series™



Select Series™

### 3 mm Ultra-Precision & High-Throughput NMR Sample Tubes

Item No.	MHz	O.D. (mm)	I.D. (mm)	Concentricity (mm)	Camber ±(mm)	Length (in)	Packed In Lots of
S-3-1000-7	1000	2.99 ± 0.003	2.41 ± 0.006	0.0018	0.0027	178	5
S-3-1000-8	1000	2.99 ± 0.003	2.41 ± 0.006	0.0018	0.0027	203	5
S-3-900-7	900	2.99 ± 0.004	2.41 ± 0.006	0.0020	0.0030	178	5
S-3-900-8	900	2.99 ± 0.004	2.41 ± 0.006	0.0020	0.0030	203	5
S-3-800-7	800	2.99 ± 0.005	2.41 ± 0.010	0.0025	0.0038	178	5
S-3-800-8	800	2.99 ± 0.005	2.41 ± 0.010	0.0025	0.0038	203	5
S-3-600-7	600	2.99 ± 0.006	2.41 ± 0.012	0.0040	0.0060	178	5
S-3-600-8	600	2.99 ± 0.006	2.41 ± 0.012	0.0040	0.0060	203	5
S-3-500-7	500	2.99 ± 0.010	2.41 ± 0.015	0.0050	0.0130	178	5
S-3-500-8	500	2.99 ± 0.010	2.41 ± 0.015	0.0050	0.0130	203	5
S-3-400-7	400	2.99 ± 0.013	2.41 ± 0.020	0.0070	0.0190	178	5
S-3-400-8	400	2.99 ± 0.013	2.41 ± 0.020	0.0070	0.0190	203	5
S-3-300-7	300	2.99 ± 0.025	2.41 ± 0.025	0.0070	0.0250	178	5
S-3-300-8	300	2.99 ± 0.025	2.41 ± 0.025	0.0070	0.0250	203	5
S-3-200-7	200	2.99 ± 0.030	2.41 ± 0.030	0.0100	0.0380	178	5
S-3-200-8	200	2.99 ± 0.030	2.41 ± 0.030	0.0100	0.0380	203	5
S-3-HT-7	HT	2.99 ± 0.030	2.41 ± 0.030	0.0110	0.0400	178	25
S-3-HT-8	HT	2.99 ± 0.030	2.41 ± 0.030	0.0110	0.0400	203	25

Select Series™ is now available in **Ultra-Thin** wall. Call **1-800-828-584-2600** or visit [www.nmrtubes.com/nmr-epr-tubes/select-series](http://www.nmrtubes.com/nmr-epr-tubes/select-series) to access our custom quote form.

NMR tubes are manufactured with round bottoms and are available with flat bottoms upon request.  
We manufacture all NMR tubes in any length upon request.

Pictured with optional NorLoc™ Cap. Select Series™ NMR Sample Tubes ship with economy caps.

# SELECT SERIES™ FOR CERAMIC TURBINES

## Select Series™ NMR Sample Tubes for Ceramic Turbines

Ceramic spinner turbines, often relied upon for variable or high temperature applications, are manufactured to extremely precise dimensional specifications.

Unlike conventional room temperature turbines made from polymers such as POM (acetal, or polyoxymethylene) and Kel-F (PCTFE, or polychlorotrifluoroethylene) or even variable temperature turbines made from PEEK (polyetheretherketone) which can flex and accommodate larger diameter tubes to a certain degree, most ceramic turbines will not tolerate even a slightly larger diameter tube.

Ceramic turbines, composed of a very hard, rigid, and brittle refractory substance, cannot flex in the slightest degree, and many of the ones currently available do not incorporate any design features permitting some degree of flexure.

To compensate for this inability, the inner diameter of ceramic turbines must be very precise and uniform from one to another, ensuring consistent performance across multiple turbines and tubes.

Accordingly, the NMR sample tubes used with ceramic turbines must meet stringent dimensional specifications as well.

When working under variable temperature conditions, the tube diameter specifications narrow and tighten even more to account for any slight thermal expansions or contractions that can result. To meet this stringent diameter requirement, Norell has developed a new line of NMR sample tubes, including both 5 mm and 3 mm O.D. sizes, that adhere to strict outside diameter specifications that are very tightly controlled. Now available in **Ultra-Thin** wall.



## Select Series™ NMR Sample Tubes for Ceramic Turbines

Item No.	MHz	O.D. (mm)	I.D. (mm)	Concentricity (mm)	Camber ± (mm)	Length (mm)	Packed In Lots Of
CTS-5-900-7	900	4.93 +0.000 -0.008	4.16 ±0.006	0.0020	0.0030	178	5
CTS-5-900-8	900	4.93 +0.000 -0.008	4.16 ±0.006	0.0020	0.0030	203	5
CTS-5-800-7	800	4.93 +0.000 -0.010	4.16 ±0.012	0.0025	0.0038	178	5
CTS-5-800-8	800	4.93 +0.000 -0.010	4.16 ±0.012	0.0025	0.0038	203	5
CTS-5-600-7	600	4.93 +0.000 -0.012	4.16 ±0.012	0.0040	0.0060	178	5
CTS-5-600-8	600	4.93 +0.000 -0.012	4.16 ±0.012	0.0040	0.0060	203	5
CTS-5-500-7	500	4.93 +0.000 -0.026	4.16 ±0.025	0.0050	0.0130	178	5
CTS-5-500-8	500	4.93 +0.000 -0.026	4.16 ±0.025	0.0050	0.0130	203	5
<b>3 mm Select Series for Ceramic Turbines</b>							
CTS-3-900-7	900	2.95 +0.000 -0.008	2.37 ±0.006	0.0020	0.0030	178	5
CTS-3-900-8	900	2.95 +0.000 -0.008	2.37 ±0.006	0.0020	0.0030	203	5
CTS-3-800-7	800	2.95 +0.000 -0.010	2.37 ±0.010	0.0025	0.0038	178	5
CTS-3-800-8	800	2.95 +0.000 -0.010	2.37 ±0.010	0.0025	0.0038	203	5
CTS-3-600-7	600	2.95 +0.000 -0.012	2.37 ±0.012	0.0040	0.0060	178	5
CTS-3-600-8	600	2.95 +0.000 -0.012	2.37 ±0.012	0.0040	0.0060	203	5
CTS-3-500-7	500	2.95 +0.000 -0.020	2.37 ±0.015	0.0050	0.0130	178	5
CTS-3-500-8	500	2.95 +0.000 -0.020	2.37 ±0.015	0.0050	0.0130	203	5

Select Series™ for Ceramic Turbines is now available in **Ultra-Thin** wall. Call **1-800-828-584-2600** or visit [www.nmrtubes.com/nmr-epr-tubes/select-series-for-ceramic-turbines](http://www.nmrtubes.com/nmr-epr-tubes/select-series-for-ceramic-turbines) to access our custom quote form.

NMR tubes are manufactured with round bottoms and are available with flat bottoms upon request.  
We manufacture all NMR tubes in any length upon request.

Pictured with optional NorLoc™ Cap. Select Series™ NMR Sample Tubes ship with economy caps.

# STANDARD SERIES™ FOR ROUTINE NMR

Our Standard Series™ NMR tubes are manufactured from ASTM Type I Class B glass, commonly referred to as N-51A. Applications that are suited for using this type of glass are routine NMR where samples are run at room temperature with no thermal gradients. It is therefore not recommended to fuse this glass with standard vacuum manifolds and the like, since these are generally made from Type I Class A glass. Each NMR tube is checked for concentricity and camber specifications utilizing the latest computer technology. At Norell®, we have taken NMR tube manufacturing to a new level of science. We manufacture all NMR tubes in any length upon request. Now available in **Ultra-Thin** wall.

## 5 mm Ultra-Precision, High-Precision & Precision NMR Sample Tubes

Item No.	MHz	O.D. (mm)	I.D. (mm)	Concentricity (mm)	Camber ±(mm)	Length (mm)	Packed In Lots of
5020-USP-7	1000	4.97 ± 0.004	4.20 ± 0.006	0.003	0.004	178	5
5020-USP-8	1000	4.97 ± 0.004	4.20 ± 0.006	0.003	0.004	203	5
5010-USP-7	750	4.97 ± 0.005	4.20 ± 0.012	0.004	0.005	178	5
5010-USP-8	750	4.97 ± 0.005	4.20 ± 0.012	0.004	0.005	203	5
509-UP-7	600	4.97 ± 0.006	4.20 ± 0.012	0.004	0.006	178	5
509-UP-8	600	4.97 ± 0.006	4.20 ± 0.012	0.004	0.006	203	5
508-UP-7	500	4.97 ± 0.013	4.20 ± 0.025	0.005	0.013	178	5
508-UP-8	500	4.97 ± 0.013	4.20 ± 0.025	0.005	0.013	203	5
507-HP-7	400	4.97 ± 0.013	4.20 ± 0.025	0.007	0.019	178	5
507-HP-8	400	4.97 ± 0.013	4.20 ± 0.025	0.007	0.019	203	5
506-P-7	300	4.97 ± 0.025	4.20 ± 0.025	0.007	0.025	178	25
506-P-8	300	4.97 ± 0.025	4.20 ± 0.025	0.007	0.025	203	25
XR-55™-7	300	4.97 ± 0.025	4.20 ± 0.025	0.010	0.038	178	25
XR-55™-8	300	4.97 ± 0.025	4.20 ± 0.025	0.010	0.038	203	25
505-P-7	200	4.97 ± 0.030	4.20 ± 0.030	0.010	0.040	178	25
505-P-8	200	4.97 ± 0.030	4.20 ± 0.030	0.010	0.040	203	25



## 5 mm Economy High-Throughput NMR Sample Tubes

Item No.	MHz	O.D. (mm)	I.D. (mm)	Concentricity (mm)	Camber ±(mm)	Length (mm)	Packed In Lots of
502-7	HT <sup>PLUS</sup>	4.97 ± 0.050	4.20 ± 0.050	0.020	0.070	178	50
502-8	HT <sup>PLUS</sup>	4.97 ± 0.050	4.20 ± 0.050	0.020	0.070	203	50
ST500-7	HT	4.97 ± 0.070	4.20 ± 0.070	0.025	0.075	178	100
ST500-8	HT	4.97 ± 0.070	4.20 ± 0.070	0.025	0.075	203	100
ST550-7	HT	4.97 ± 0.070	4.20 ± 0.070	0.025	0.075	178	5
ST550-8	HT	4.97 ± 0.070	4.20 ± 0.070	0.025	0.075	203	5

Standard Series™ is now available in **Ultra-Thin** wall. Call **1-800-828-584-2600** or visit [www.nmrtubes.com/nmr-epr-tubes/standard-series](http://www.nmrtubes.com/nmr-epr-tubes/standard-series) to access our custom quote form. Pictured with optional NorLoc™ Cap. Standard Series™ NMR Sample Tubes ship with economy caps.

## 10 mm Ultra-Precision & Precision NMR Sample Tubes

Item No.	MHz	O.D. (mm)	I.D. (mm)	Concentricity (mm)	Camber ±(mm)	Length (mm)	Packed In Lots of
1008-UP-7	400	9.98 ± 0.013	8.76 ± 0.025	0.005	0.007	178	5
1008-UP-8	400	9.98 ± 0.013	8.76 ± 0.025	0.005	0.007	203	5
1005-P-7	300	9.98 ± 0.016	8.76 ± 0.025	0.020	0.013	178	5
1005-P-8	300	9.98 ± 0.016	8.76 ± 0.025	0.020	0.013	203	5

## 10 mm Economy NMR Sample Tubes

Item No.	MHz	O.D. (mm)	I.D. (mm)	Concentricity (mm)	Camber ±(mm)	Length (mm)	Packed In Lots of
1001-7	200	9.98 ± 0.024	8.76 ± 0.025	nominal	nominal	178	100
1001-8	200	9.98 ± 0.024	8.76 ± 0.025	nominal	nominal	203	100

## 10 mm Ultra-Precision & Precision Flat Bottom NMR Sample Tubes

Item No.	MHz	O.D. (mm)	I.D. (mm)	Concentricity (mm)	Camber ±(mm)	Length (mm)	Packed In Lots of
1008-UP-FB-7	400	9.98 ± 0.013	8.76 ± 0.025	0.005	0.007	178	5
1008-UP-FB-8	400	9.98 ± 0.013	8.76 ± 0.025	0.005	0.007	203	5
1005-P-FB-7	300	9.98 ± 0.016	8.76 ± 0.025	0.020	0.013	178	5
1005-P-FB-8	300	9.98 ± 0.016	8.76 ± 0.025	0.020	0.013	203	5

## 10 mm Economy Flat Bottom NMR Sample Tubes

Item No.	MHz	O.D. (mm)	I.D. (mm)	Concentricity (mm)	Camber ±(mm)	Length (mm)	Packed In Lots of
1001-FB-7	200	9.98 ± 0.024	8.76 ± 0.025	nominal	nominal	178	100
1001-FB-8	200	9.98 ± 0.024	8.76 ± 0.025	nominal	nominal	203	100



STANDARD SERIES™

NORELL® Reinforced Bottom NMR Tube

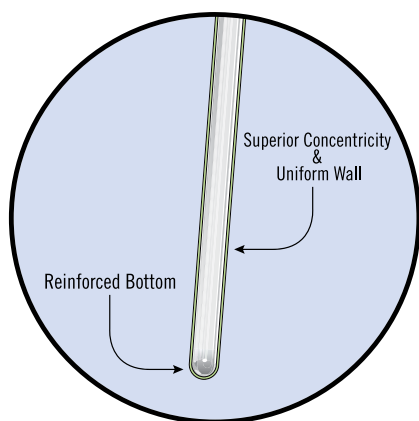

NORELL® Flat Bottom NMR Tube

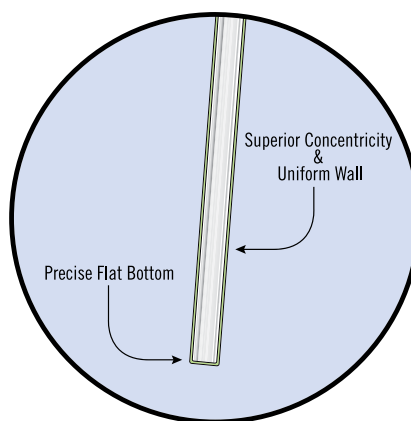

Through our advanced manufacturing process, the NMR tube bottoms are uniformly hemispherical and consistent, thereby minimizing shimming and susceptibility differences among samples. This uniformity extends throughout the wall thickness of the tubes, maximizing the concentricity among tubes and lots. This translates to more consistent placement of the contained sample volumes in today's advanced, highly homogeneous, high field NMR magnets.

Standard Series™ is now available in **Ultra-Thin** wall. Call **1-800-828-584-2600** or visit [www.nmrtubes.com/nmr-epr-tubes/standard-series](http://www.nmrtubes.com/nmr-epr-tubes/standard-series) to access our custom quote form. Pictured with optional NorLoc™ Cap. Standard Series™ NMR Sample Tubes ship with economy caps.

## ULTRATHIN SERIES ULTRA-THIN WALL NMR TUBES

Our **ULTRATHIN** Series NMR tubes are designed to elevate your spectroscopic analysis. Available in 5 mm and 10 mm outer diameters, these tubes feature significantly reduced wall thicknesses compared to traditional options. The 5 mm tubes have a 0.29 mm wall, down from the **STANDARD SERIES** 0.43 mm, while the 10 mm tubes slim down to 0.42 mm from 0.59 mm. This reduction in wall thickness translates to a larger sample volume, allowing for enhanced signal-to-noise ratios and improved sensitivity in your NMR experiments. The sample volume within the RF coil for the 5 mm tube is approximately 151  $\mu\text{L}$  and the 10 mm is approximately 654  $\mu\text{L}$  assuming a 25 mm active height. Both 5 mm and 10 mm **ULTRATHIN** wall series tubes increase sample volume approximately 10%.

Our **ULTRATHIN** NMR tubes are crafted from high-quality Type I borosilicate glass, known for its excellent chemical resistance and low thermal expansion. They are rated for a wide temperature range, up to +200°C, making them suitable for both low and high-temperature NMR studies. The thinner walls facilitate better heat transfer, ensuring more uniform temperature control throughout your sample.

Additionally, these **ULTRATHIN** tubes minimize the background signal from the glass, resulting in cleaner spectra and more precise data. The tubes maintain high precision roundness and are rigorously tested to meet stringent quality standards. Whether you're working with precious samples or seeking to push the boundaries of NMR analysis, our **ULTRATHIN** series offers the perfect blend of performance and precision for your research needs.

### How thin is **ULTRATHIN**?



**ULTRATHIN:**  
0.29 mm Tube Wall



**Select Series:**  
0.38 mm Tube Wall



**Standard Series:**  
0.43 mm Tube Wall



### 5 mm Ultra-Thin Wall NMR Sample Tubes

Item No.	MHz	O.D. (mm)	I.D. (mm)	Concentricity (mm)	Camber ±(mm)	Length (mm)	Packed In Lots of
UTW-5-1200-7	1200	4.97 ± 0.003	4.39 ± 0.004	0.001	0.002	178	5
UTW-5-1200-8	1200	4.97 ± 0.003	4.39 ± 0.004	0.001	0.002	203	5
UTW-5-1000-7	1000	4.97 ± 0.004	4.39 ± 0.006	0.003	0.004	178	5
UTW-5-1000-8	1000	4.97 ± 0.004	4.39 ± 0.006	0.003	0.004	203	5
UTW-5-750-7	750	4.97 ± 0.005	4.39 ± 0.012	0.004	0.005	178	5
UTW-5-750-8	750	4.97 ± 0.005	4.39 ± 0.012	0.004	0.005	203	5
UTW-5-600-7	600	4.97 ± 0.006	4.39 ± 0.012	0.004	0.006	178	5
UTW-5-600-8	600	4.97 ± 0.006	4.39 ± 0.012	0.004	0.006	203	5
UTW-5-500-7	500	4.97 ± 0.013	4.39 ± 0.025	0.005	0.013	178	5
UTW-5-500-8	500	4.97 ± 0.013	4.39 ± 0.025	0.005	0.013	203	5

Pictured with optional NorLoc™ Cap. Ultra-Thin™ NMR Sample Tubes ship with economy caps.



### 10 mm Ultra-Thin Wall NMR Sample Tubes

Item No.	MHz	O.D. (mm)	I.D. (mm)	Concentricity (mm)	Camber ±(mm)	Length (mm)	Packed In Lots of
UTW-10-1200-7	1200	9.98 ± 0.003	9.14 ± 0.006	0.002	0.003	178	5
UTW-10-1200-8	1200	9.98 ± 0.003	9.14 ± 0.006	0.002	0.003	203	5
UTW-10-1000-7	1000	9.98 ± 0.004	9.14 ± 0.008	0.003	0.004	178	5
UTW-10-1000-8	1000	9.98 ± 0.004	9.14 ± 0.008	0.003	0.004	203	5
UTW-10-750-7	750	9.98 ± 0.006	9.14 ± 0.013	0.004	0.006	178	5
UTW-10-750-8	750	9.98 ± 0.006	9.14 ± 0.013	0.004	0.006	203	5
UTW-10-600-7	600	9.98 ± 0.008	9.14 ± 0.015	0.005	0.007	178	5
UTW-10-600-8	600	9.98 ± 0.008	9.14 ± 0.015	0.005	0.007	203	5
UTW-10-500-7	500	9.98 ± 0.015	9.14 ± 0.030	0.006	0.008	178	5
UTW-10-500-8	500	9.98 ± 0.015	9.14 ± 0.030	0.006	0.008	203	5

## ULTRATHIN SERIES ULTRA-THIN WALL NMR TUBES

Also available for the **Special Purpose** NMR Products seen below.  
See the “**Special Purpose**” section starting on page 24.



**ULTRATHIN** Screw-Cap Pg. 40



**ULTRATHIN** Amberized Pg. 42



**ULTRATHIN** Constricted Pg. 42



**ULTRATHIN** Reduced Pressure Valve Pg. 26



**ULTRATHIN** Intermediate Pressure Valve Pg. 30



**ULTRATHIN** Extreme Pressure Valve Pg. 36

**Secure Series™** Enhanced with patented proprietary technology, delivering confidence in your results. Advanced features include our NorLoc™ cap that pairs seamlessly with our security band for superior sample containment, while specialized surface treatment ensures safe, stable positioning within the turbine.  
**Available in lots of 5, 25, 50, or 100.**

**AUTOMATED SYSTEMS**

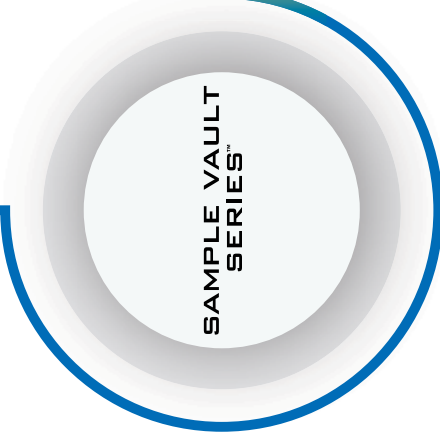

**Sample Vault Series™** Designed for demanding high-throughput use and seamless compatibility with Bruker's SampleJet automated system. Each NMR tube comes equipped with barcoded NorLoc™ caps, ensuring flawless integration. Available in both 103.5 mm and 178 mm lengths, with 103.5 mm open-port products conveniently pre-loaded in our fully compatible Sample Vault™ NMR tube rack.  
**Available in lots of 96.**

**THERMAL SHOCK RESISTANCE**



**Select Series™** Offers a high degree of thermal shock resistance with low expansion coefficient. Recommended for research involving variable temperature applications, freeze/thaw cycling, or any other application where significant temperature variations are required.  
**Available in lots of 5.**

**Standard Series™** The ideal choice for routine NMR applications. This versatile line of NMR tubes combines high-throughput durability with superior precision for optimal analytical performance.  
**Available in lots of 5, 25, 50 or 100.**



**ROUTINE NMR**

SAMPLE VAULT SERIES™

SECURE SERIES™

Select Series™

STANDARD SERIES™

## Integrated Closure System

Sample Vault™ Series NMR tubes with Sample Vault™ caps (U.S. Patent No. 8,054,080) are engineered for a new generation of high-throughput lab automation systems, including the Bruker SampleJet. Designed to be used with 96-position carriers using 103.5 mm (about 4") long NMR tubes with open port caps, or 178 mm (7") long NMR tubes with closed port caps, Sample Vault™ caps have superior holding and sealing capabilities which eliminate cap/tube failure in your instrument. Our patented design incorporates a white band positioned on the NMR tube that aligns with the base of the cap, indicating a properly locked position. Together, our Sample Vault™ caps and Sample Vault™ tubes form an integrated closure system for fail-safe delivery of your sample into the magnet. We offer Sample Vault™ tubes in 1 mm, 1.7 mm, 3 mm, and 5 mm outer diameters for use up to 700 MHz and 950 MHz. Our proven quality and innovative engineering speak for themselves.

- Engineered for a new generation of high-throughput lab automation systems, such as the SampleJet™ system from Bruker.
- Two precision types available for up to 700 MHz and 950 MHz spectrometers.
- Superior Sample Vault™ cap (U.S. Patent No. 8,054,080) attaches semi-permanently for multiple uses and for critical applications.
- Choice of two Sample Vault™ cap styles: either closed port or open port, giving you the ultimate in choice of sample sealing.
- Closures are available to seal the Sample Vault™ Open Port caps. They are made of a soft, resilient silicone rubber that forms a very effective seal, with a high degree of inertness, solvent resistance, and high temperature capability (up to 200°C). The closures are easily removed and may be trimmed to length with a knife blade or scissors.
- Safe for cold refrigeration storage, works with cryo-probes and variable temperature studies.



Sample Vault™ Series is now available in **Ultra-Thin** wall. Call **1-800-828-584-2600** or visit [www.nmrtubes.com/nmr-epr-tubes/sample-vault-tm-nmr-sample-tube-rack](http://www.nmrtubes.com/nmr-epr-tubes/sample-vault-tm-nmr-sample-tube-rack) to access our custom quote form.

## Sample Vault™ Series NMR Tubes & Caps Specifications

PACKED IN LOTS OF 96 WITH CAPS. CHOOSE OPEN OR CLOSED PORT.

Item No.	MHz Rating	Cap Type	Cap Color	OD	Wall Size	Concentricity	Camber	Length
SVCP-5-103.5-96PK	Up to 700 MHz	Closed/Coded	Black	5 mm	0.38 mm	40 µm	60 µm	103.5 mm
SVCP-5-178-96PK	Up to 700 MHz	Closed/Uncoded	Black	5 mm	0.38 mm	40 µm	60 µm	178 mm
SVCP-3-103.5-96PK	Up to 700 MHz	Closed/Coded	Black	3 mm	0.38 mm	40 µm	60 µm	103.5 mm
SVCP-3-178-96PK	Up to 700 MHz	Closed/Uncoded	Black	3 mm	0.38 mm	40 µm	60 µm	178 mm
SVCP-Super-5-103.5-96PK	Up to 950 MHz	Closed/Uncoded	Red	5 mm	0.38 mm	20 µm	30 µm	103.5 mm
SVOP-Super-5-103.5-96PK	Up to 950 MHz	Open/Uncoded	White	5 mm	0.38 mm	20 µm	30 µm	103.5 mm
SVCP-Super-5-178-96PK	Up to 950 MHz	Closed/Uncoded	Red	5 mm	0.38 mm	20 µm	30 µm	178 mm
SVOP-Super-5-178-96PK	Up to 950 MHz	Open/Uncoded	White	5 mm	0.38 mm	20 µm	30 µm	178 mm
SVCP-Super-3-103.5-96PK	Up to 950 MHz	Closed/Uncoded	Red	3 mm	0.38 mm	20 µm	30 µm	103.5 mm
SVOP-Super-3-103.5-96PK	Up to 950 MHz	Open/Uncoded	White	3 mm	0.38 mm	20 µm	30 µm	103.5 mm
SVCP-Super-3-178-96PK	Up to 950 MHz	Closed/Uncoded	Red	3 mm	0.38 mm	20 µm	30 µm	178 mm
SVOP-Super-3-178-96PK	Up to 950 MHz	Open/Uncoded	White	3 mm	0.38 mm	20 µm	30 µm	178 mm

## Medium Wall and Heavy Wall Sample Vault™ NMR Tubes

PACKED IN LOTS OF 5 WITH CAPS. CHOOSE OPEN OR CLOSED PORT.

Item No.	MHz Rating	Cap Type	OD (mm)	ID (mm)	Wall (mm)	Length (mm)	Concentricity	Camber
SVCP-Super-5-MW-103.5-5	Up to 950 MHz	Closed	4.97 ± 0.013	3.43 ± 0.025	0.8	103.5	20 µm	30 µm
SVOP-Super-5-MW-103.5-5	Up to 950 MHz	Open	4.97 ± 0.013	3.43 ± 0.025	0.8	103.5	20 µm	30 µm
SVCP-Super-5-HW-103.5-5	Up to 950 MHz	Closed	4.97 ± 0.013	2.20 ± 0.025	1.4	103.5	20 µm	30 µm
SVOP-Super-5-HW-103.5-5	Up to 950 MHz	Open	4.97 ± 0.013	2.20 ± 0.025	1.4	103.5	20 µm	30 µm

## Closed Port Sample Vault™ Caps

PACKED IN LOTS OF 96

Item No.	Cap Type	Cap Color	Size
SVCP-SAMPLEVAULT-3-96PK	Closed Port	Red	3 mm
SVCP-SAMPLEVAULT-5-96PK	Closed Port	Red	5 mm
SVCP-CC-SAMPLEVAULT-3-96PK-BO	Closed/Coded	Black	3 mm
SVCP-CC-SAMPLEVAULT-5-96PK-BO	Closed/Coded	Black	5 mm

## SAMPLE VAULT SERIES™ Coded Caps for Bruker SampleJet

### Sample Vault™ NMR Sample Tube Rack

NMR sample tube rack manufactured from laboratory engineered high strength & high modulus biopolymer

- 96 position NMR sample tube rack for use in SampleJet systems
- Available with coded, open port Sample Vault™ NMR sample tube caps
- Available with 1 mm, 1.7 mm, 3 mm & 5 mm NMR sample tubes

*SampleJet is a trademark of Bruker-Physik AG*

Available in coded with open port for  
1 mm, 1.7 mm, 3 mm & 5 mm applications.



### 1 mm, 1.7mm, 3 mm & 5 mm Sample Vault™ Series NMR Tubes & Caps for Bruker SampleJet

PACKED IN LOTS OF 96 WITH CAPS. SHIPS IN OUR COMPOSTABLE BIOPOLYMER TUBE RACK.

U.S. Patent No. 8,054,080

Item No.	MHz Rating	Cap Type	Cap Color	OD	Wall Size	Concentricity	Camber	Length
SVOP-5-103.5-96PK	Up to 900 MHz	Coded Open	Black	5 mm	0.38 mm	40 µm	60 µm	103.5 mm
SVOP-3-103.5-96PK	Up to 900 MHz	Coded Open	Black	3 mm	0.38 mm	40 µm	60 µm	103.5 mm
SVOP-1.7-103.5-96PK	Up to 900 MHz	Coded Open	Gray	1.7 mm	0.20 mm	40 µm	60 µm	103.5 mm
SVOP-1-103.5-96PK	Up to 900 MHz	Coded Open	Black	1 mm	0.10 mm	40 µm	60 µm	103.5 mm

### Spherical Closures to Seal the Sample Vault™ Open Port Caps

THIS CLOSURE WILL FIT THE 1 MM, 1.7 MM, 3 MM AND 5 MM SAMPLE VAULT™ OPEN PORT CAPS

Item No.	Description	Color	Packed in Lots of
OPC-100PK	Spherical Closure	White	100



Spherical Closure for Open Port Cap

### Silicone Closures to Seal the Sample Vault™ Open Port Caps

THIS CLOSURE WILL FIT THE 1 MM, 1.7 MM, 3 MM AND 5 MM SAMPLE VAULT™ OPEN PORT CAPS

Item No.	Description	Color	Packed in Lots of
SVC-SAMPLEVAULT-SRS	Tapered Silicone	Clear	50
	Rubber Plug	Translucent	100



Tapered Silicone Closure for Open Port Cap

• Not for use in Bruker SampleJet

Sample Vault™ Series for Bruker SampleJet is now available in **Ultra-Thin** wall. Call **1-800-828-584-2600** or visit [www.nmrtubes.com/nmr-epr-tubes/sample-vault-tm-nmr-sample-tube-rack](http://www.nmrtubes.com/nmr-epr-tubes/sample-vault-tm-nmr-sample-tube-rack) to access our custom quote form.

# SAMPLE VAULT™ SERIES NMR TUBES & CAPS

U.S. Patent No. 8,054,080

## Sample Vault™ 1 mm & 1.7 mm NMR Sample Tubes & Caps for Bruker SampleJet

Our patented Sample Vault™ NMR tubes and caps use our proprietary heat sealing treatment to ensure permanent, slip-free sample containment. Three internal lobes are heat molded to our patented surface treatment on the NMR sample tube to form a secure bond between the cap and the NMR tube. 1 mm & 1.7 mm Sample Vault™ NMR tubes ship in our 96-position, biopolymer NMR sample tube rack for use in SampleJet systems.

### 1 mm & 1.7 mm Sample Vault™ NMR Tubes & Caps Anatomy

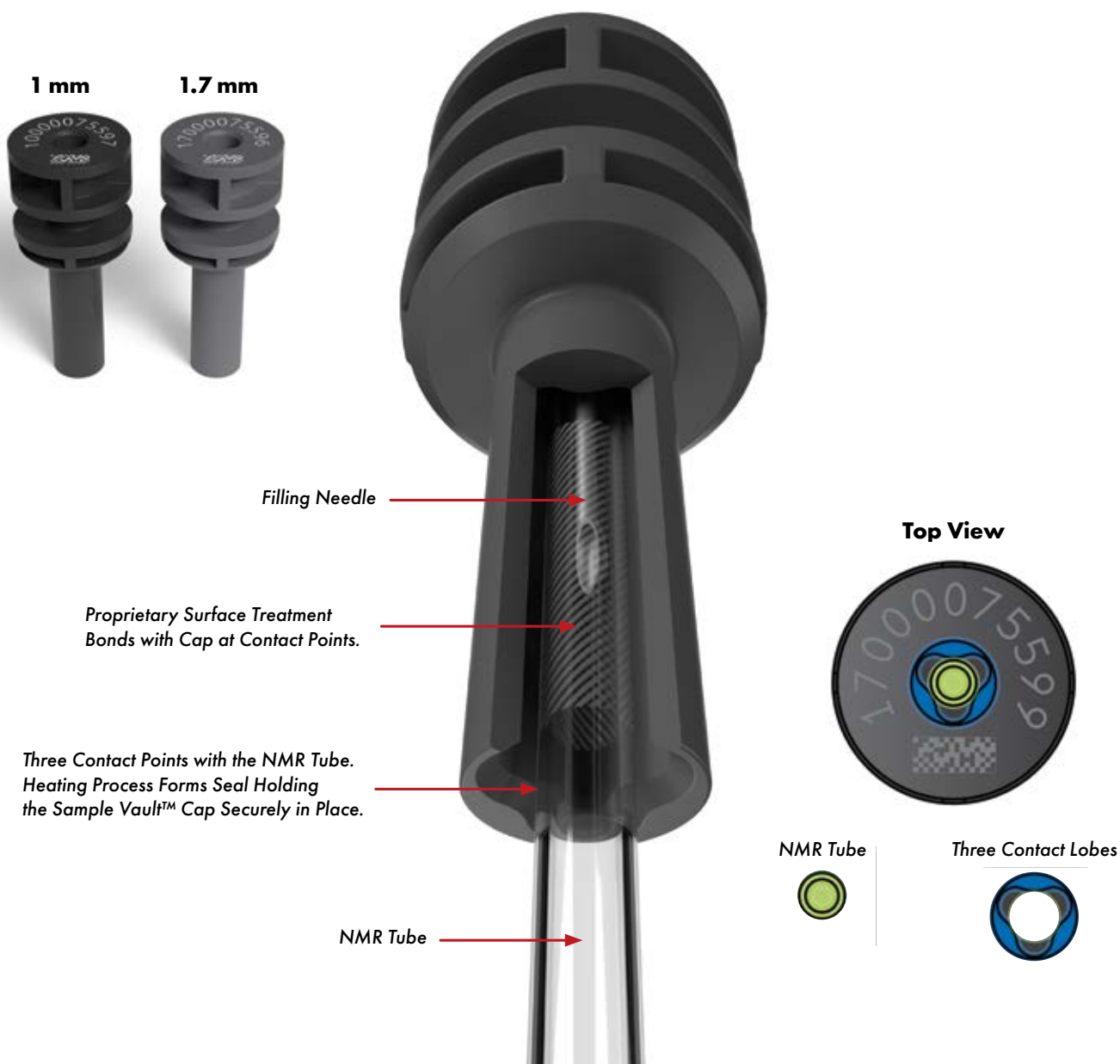

## 1 mm & 1.7 mm Sample Vault™ Series NMR Tubes & Caps for Bruker SampleJet

PACKED IN LOTS OF 96 WITH CAPS. SHIPS IN OUR COMPOSTABLE BIOPOLYMER TUBE RACK.

Item No.	MHz Rating	Cap Type	Cap Color	OD	Wall Size	Concentricity	Camber	Length
SVOP-1-103.5-96PK	Up to 900 MHz	Coded Open	Black	1 mm	0.38 mm	40 µm	60 µm	103.5 mm
SVOP-1.7-103.5-96PK	Up to 900 MHz	Coded Open	Gray	1.7 mm	0.38 mm	40 µm	60 µm	103.5 mm

### 1.7 mm Sample Vault Tube/Cap

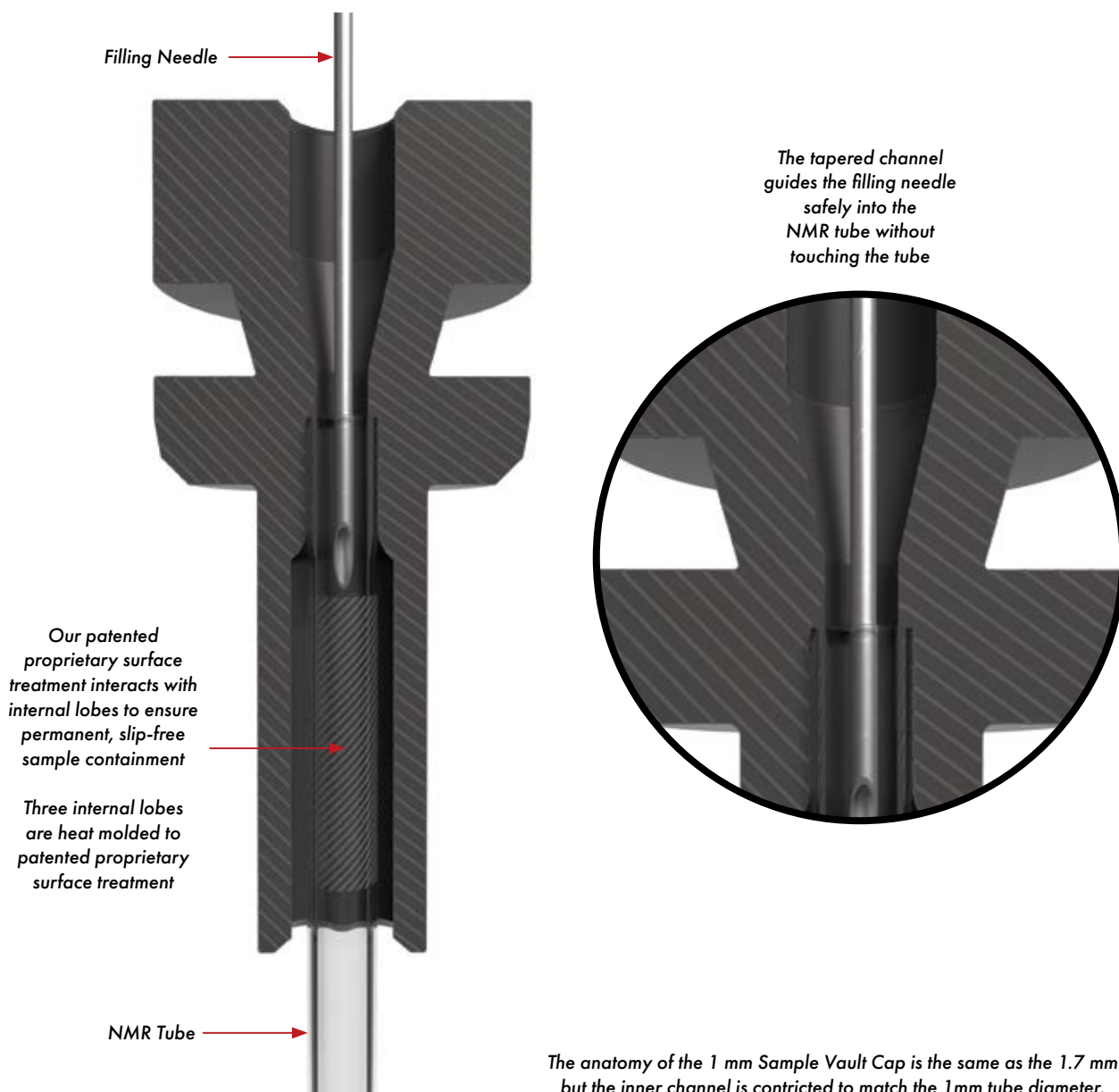

# SPECIAL PURPOSE SAMPLE TUBES

## 5 mm Natural Quartz NMR Sample Tubes

Experience unmatched precision with our premium quartz NMR tubes. Crafted from ultra-pure fused silica with flawless uniformity, these tubes deliver exceptional magnetic homogeneity for superior spectral resolution. Each tube meets exacting dimensional standards, ensuring reliable results every time. Perfect for demanding NMR applications where accuracy is paramount. Natural Quartz EPR Tubes also available.

Recommended for Boron NMR [ $< 0.1$  ppm Boron] and/or UV-catalyzed reactions in the region above 210 nm [90%T @ 210 nm]. Medium and heavy wall NMR tubes are now available, in addition to standard, thin wall NMR tubes, as shown in the tables below.

### 5 mm Thin Wall Natural Quartz NMR Sample Tubes

Item No.	MHz	O.D. (mm)	I.D. (mm)	Length (mm)	Packed In Lots of
S-5-500-QTZ-7	500	4.97 ± 0.013	4.20 ± 0.025	178	5
S-5-500-QTZ-8	500	4.97 ± 0.013	4.20 ± 0.025	203	5
S-5-600-QTZ-7	600	4.97 ± 0.006	4.20 ± 0.012	178	5
S-5-600-QTZ-8	600	4.97 ± 0.006	4.20 ± 0.012	203	5

### 5 mm Medium Wall Natural Quartz NMR Sample Tubes

Item No.	MHz	O.D. (mm)	I.D. (mm)	Length (mm)	Packed In Lots of
S-5-500-QTZ-MW-7	500	4.95 ± 0.013	3.40 ± 0.025	178	1
S-5-500-QTZ-MW-8	500	4.95 ± 0.013	3.40 ± 0.025	203	1
S-5-600-QTZ-MW-7	600	4.95 ± 0.006	3.40 ± 0.012	178	1
S-5-600-QTZ-MW-8	600	4.95 ± 0.006	3.40 ± 0.012	203	1

### 5 mm Heavy Wall Natural Quartz NMR Sample Tubes

Item No.	MHz	O.D. (mm)	I.D. (mm)	Length (mm)	Packed In Lots of
S-5-500-QTZ-HW-7	500	4.95 ± 0.013	2.15 ± 0.025	178	1
S-5-500-QTZ-HW-8	500	4.95 ± 0.013	2.15 ± 0.025	203	1
S-5-600-QTZ-HW-7	600	4.95 ± 0.006	2.15 ± 0.012	178	1
S-5-600-QTZ-HW-8	600	4.95 ± 0.006	2.15 ± 0.012	203	1

Pictured with optional NorLoc™ Cap. Natural Quartz NMR Sample Tubes ship with economy caps.



## Natural Quartz EPR Sample Tubes

Norell EPR tubes produce lower background signals and have better resistance to breakage than competitor brands. Our proprietary technical treatment reduces background noise along with the benefit of protecting against tube breakage. Additionally, we have designed a new fluoropolymer closure system around our fire-polished tube ends that prevents sample loss during temperature gradients. Available in both standard and ultra precision. Supplied with tapered fluoropolymer caps.

Item No.	O.D. (mm)	I.D. (mm)	Wall (mm)	Length (mm)	Packed In Lots Of
S-4-2-EPR-250S	4.0	2.0	1.00	250	5
S-4-EPR-250S	4.0	3.0	0.50	250	5
S-4-EPR-250P	3.98 ± 0.015	2.95 ± 0.025	0.51	250	5
S-5-EPR-250S	5.0	4.0	0.50	250	5
S-5-EPR-250P	4.97 ± 0.013	4.14 ± 0.008	0.41	250	5

## 5 mm Suprasil® Quartz NMR Sample Tubes

Recommended for Boron NMR [ $< 0.01$  ppm Boron] and/or UV-catalyzed reactions in the region above 190 nm [90%T @ 190 nm].

Item No.	MHz	O.D. (mm)	I.D. (mm)	Length (mm)	Packed in Lots of
S-5-500-SQTZ-7	500	4.97 ± 0.013	4.20 ± 0.025	178	1
S-5-500-SQTZ-8	500	4.97 ± 0.013	4.20 ± 0.025	203	1
S-5-600-SQTZ-7	600	4.97 ± 0.006	4.20 ± 0.012	178	1
S-5-600-SQTZ-8	600	4.97 ± 0.006	4.20 ± 0.012	203	1

## Suprasil® Quartz EPR Sample Tubes

Recommended for UV-catalyzed reactions in the region at and above 190 nm. Provides greater reduction of background noise than natural quartz and is used primarily in studies where greater signal sensitivity is needed. Supplied with tapered fluoropolymer caps.

Item No.	O.D. (mm)	I.D. (mm)	Wall (mm)	Length (mm)	Packed in Lots of
S-4-EPRSQ-250S	4.0	3.0	0.50	250	1
S-4-EPRSQ-250P	3.98 ± 0.015	2.95 ± 0.025	0.51	250	1
S-5-EPRSQ-250S	5.0	4.0	0.50	250	1
S-5-EPRSQ-178P	4.97 ± 0.013	3.98 ± 0.08	0.50	178	1
S-5-EPRSQ-200P	4.97 ± 0.013	3.98 ± 0.08	0.50	200	1
S-5-EPRSQ-250P	4.97 ± 0.013	3.98 ± 0.08	0.50	250	1



S-5-500-SQTZ

Pictured with optional NorLoc™ Cap. Quartz EPR & NMR Sample Tubes ship with economy caps.

# SPECIAL PURPOSE SAMPLE TUBES

## Valved NMR Tubes for Vacuum & Reduced Pressure

Handle your NMR sample without flame-sealing your tubes. Fluoropolymer-covered o-ring eliminates material incompatibilities. Completely greaseless fluoropolymer assembly, which is easy to use and to disassemble for cleaning. Includes female joint for quick attachment to your vacuum rack.

A vacuum level of 10<sup>-7</sup> kPa (10<sup>-6</sup> torr) can be attained with this valve. While this valve can also withstand an internal positive pressure to 500 kPa (5 bar, 72 psi), the VT Valved NMR Tube series is intended principally for vacuum work. When pressurizing internally (by heating the NMR tube, for instance), the valve must be fully closed, so that the female vacuum adapter joint (the short glass tube that slips over the top of the PTFE valve stem, sealing against the upper o-rings) cannot be used to apply or be exposed to positive pressure.

The adjoining tables present a selection of 3 and 5 mm O.D. NMR tubes joined to the VT style valves. However, other tube diameters, lengths (such as 133 mm for automated sampling), additional MHz ratings, and tube materials (such as quartz) are available. Please feel free to request a quote on your custom requirements, as we are continually striving to provide the utmost service and satisfaction to our customers! Available with **ULTRATHIN** wall NMR Tubes.

## NOW AVAILABLE FOR AUTOMATED SYSTEMS

Custom NMR sample tube lengths for our Reduced Pressure Valve now available for automated sampling systems.

### 5 mm Valved NMR Tubes for Vacuum & Reduced Pressure

Item No.	MHz	Length (mm)	I.D. mm (Volume $\mu\text{L}/\text{cm}$ )
S-5-500-VT-7	500	178	4.20 (138)
S-5-500-VT-8	500	203	4.20 (138)
S-5-600-VT-7	600	178	4.20 (138)
S-5-600-VT-8	600	203	4.20 (138)
<b>Valved NMR for Automated Sampling</b>			
S-5-500-VT-AS	500	133	4.20 (138)
S-5-600-VT-AS	600	133	4.20 (138)
<b>ULTRATHIN Valved NMR</b>			
S-5-500-VT-UTW-7	500	178	4.39 (144)
S-5-500-VT-UTW-8	500	203	4.39 (144)
S-5-600-VT-UTW-7	600	178	4.39 (144)
S-5-600-VT-UTW-8	600	203	4.39 (144)
S-5-500-VT-UTW-AS	500	133	4.39 (144)
S-5-600-VT-UTW-AS	600	133	4.39 (144)

### 3 mm Valved NMR Tubes for Vacuum & Reduced Pressure

Item No.	MHz	Length (mm)	I.D. mm (Volume $\mu\text{L}/\text{cm}$ )
S-3-500-VT-7	500	178	2.41 (46)
S-3-500-VT-8	500	203	2.41 (46)
S-3-600-VT-7	600	178	2.41 (46)
S-3-600-VT-8	600	203	2.41 (46)
<b>Valved NMR for Automated Sampling</b>			
S-3-500-VT-AS	500	133	2.41 (46)
S-3-600-VT-AS	600	133	2.41 (46)

# Valved NMR Tubes for Vacuum & Reduced Pressure

**133 mm Reduced Pressure  
NMR Tube Attached**  
*Compatible with Automated Samplers*

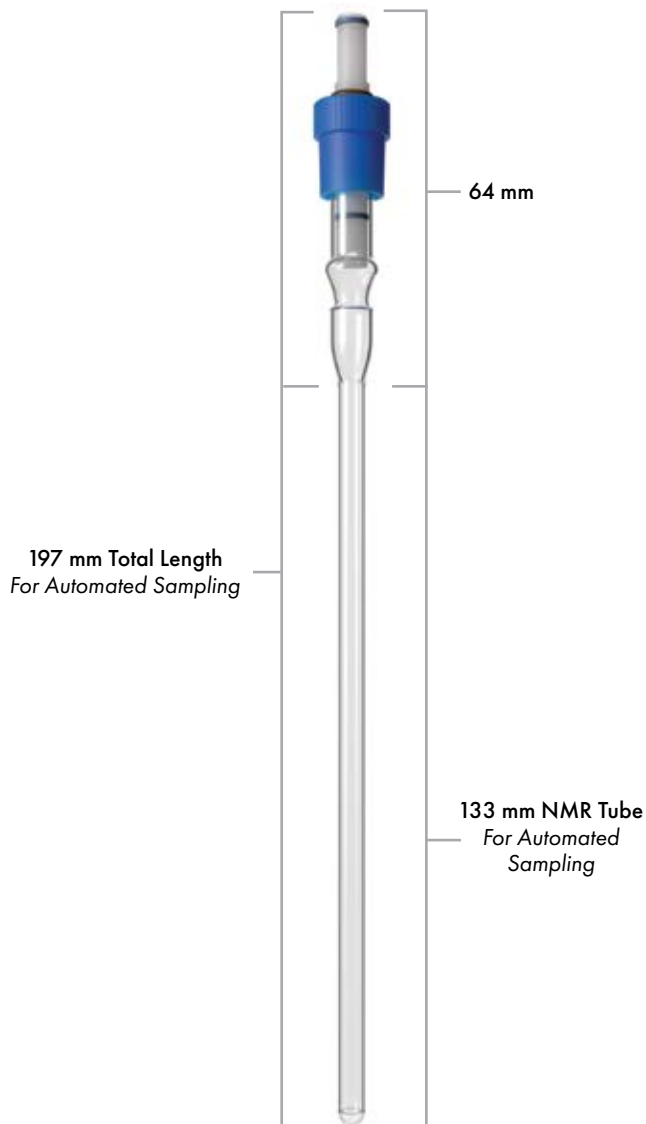

**Optional  
178 mm or 203 mm  
NMR Tube Attachment**  
*For Pressurized NMR*

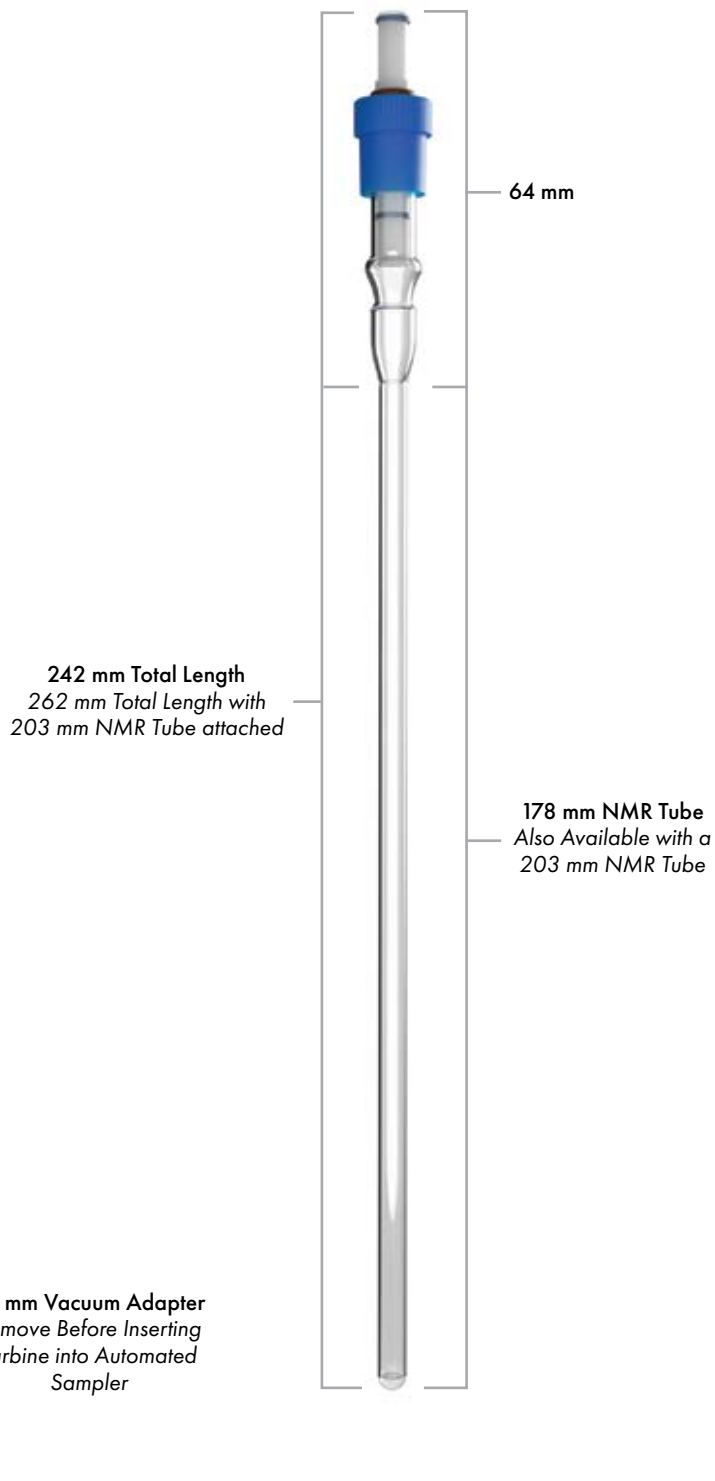

*Due to the hand crafted nature of our pressure valves overall valve assembly length can vary slightly.  
A typical variance is 1-2 mm. Overall length is based on a fully seated operating cap.*

# SPECIAL PURPOSE SAMPLE TUBES

## Valved NMR Tubes for Vacuum & Reduced Pressure

The VT Valved NMR Sample Tubes are designed principally for negative pressure use, from slightly less than ambient pressure to high vacuum ( $10^{-7}$  kPa or  $10^{-6}$  torr) using the supplied female vacuum adapter joint.

A glassblower can seal the glass female joint to a glass vacuum manifold for the most reliable, permanent connection, but the female vacuum joint can also be attached to the vacuum source using rubber or other vacuum hose as a simpler alternative.

The VT Valved NMR Sample Tube can also withstand an internally generated positive pressure to 500 kPa (5 bar, 72 psi) when the valve is tightly closed, by, for example, heating the contents of the NMR tube, or from pressure generated internally by a chemical reaction.

However, the female vacuum adapter joint must not be used to apply positive pressure, or be exposed to positive pressure, because it is held onto the PTFE valve plug by a frictional slip-fit only.

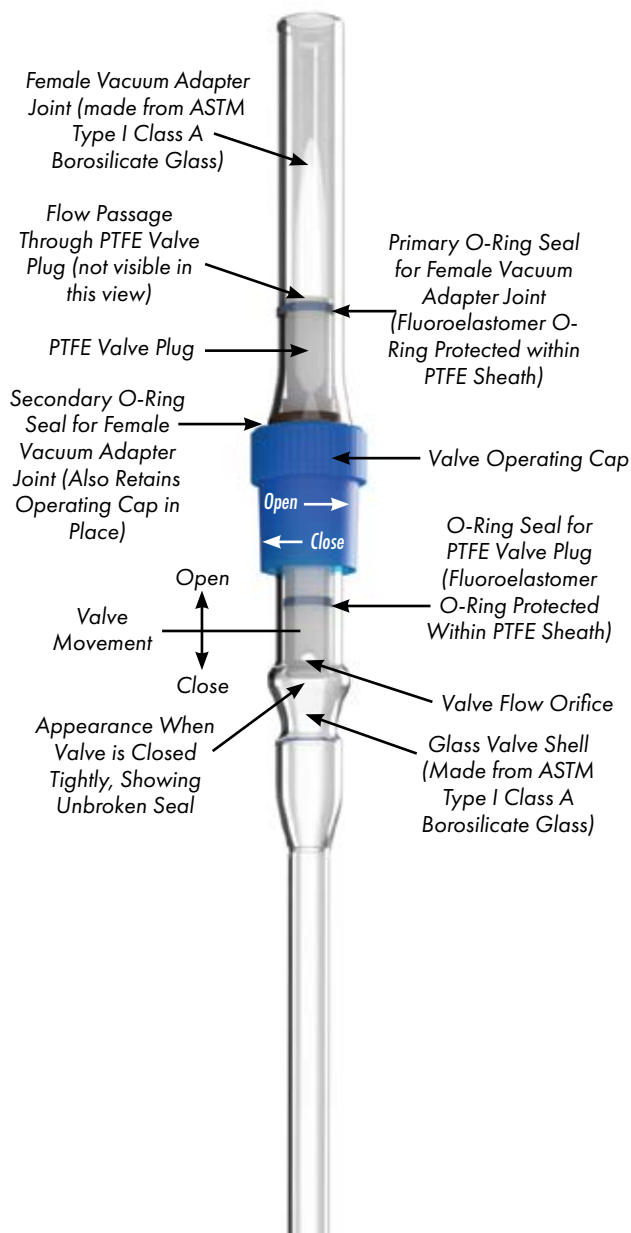

**1.** Once installed in the vacuum system, the female vacuum adapter joint enables fast and easy connection or disconnection of the VT Valved NMR tube to the vacuum source. To connect, simply push the end of the white PTFE valve plug into the female adapter joint until the flared end of the female joint contacts the lower, secondary o-ring seal, as shown in the adjacent Figure 1.

**2.** Commence evacuation of the VT Valved NMR tube by turning the Valve Operating Cap counter-clockwise (CCW) to lift the PTFE valve plug from its seated position and open the valve. Gas flow can now proceed from the interior of the VT Valved NMR tube through the open valve seat, into the expanded bulb of the glass valve shell, then into the Valve Flow Orifice at the bottom of the PTFE valve plug to finally be exhausted from the system through the axial flow passage of the PTFE valve plug.

**3.** Upon evacuation to the desired level, the VT Valved NMR tube can, for example, be used as a “cold finger” trap to collect sample by vacuum distillation, or pre-contained sample may be easily purified through a series of “freeze-pump-thaw” cycles to remove traces of paramagnetic oxygen gas. Very importantly, however, only the NMR tube should be cooled to cryogenic temperatures, because the PTFE valve plug contracts and shortens considerably more than glass, and in some instances may therefore become too short to reach the valve seat and seal tightly.

**4.** To disconnect the VT Valved NMR tube upon completion of the vacuum work, first ensure that the VT valve is closed tightly, as shown by the white band of contact (Figure 1 at bottom) by turning the Valve Operating Cap fully clockwise (CW). After closing any additional valve(s) as necessary to the vacuum source, the end of the VT Valved NMR tube can be gently pulled free from the female vacuum adapter joint to be taken elsewhere as needed.

**5.** To disassemble the VT Valved NMR tube for cleaning, turn the Valve Operating Cap counter-clockwise (CCW) until the threads disengage. The white PTFE valve plug can now be carefully removed from the glass valve shell.

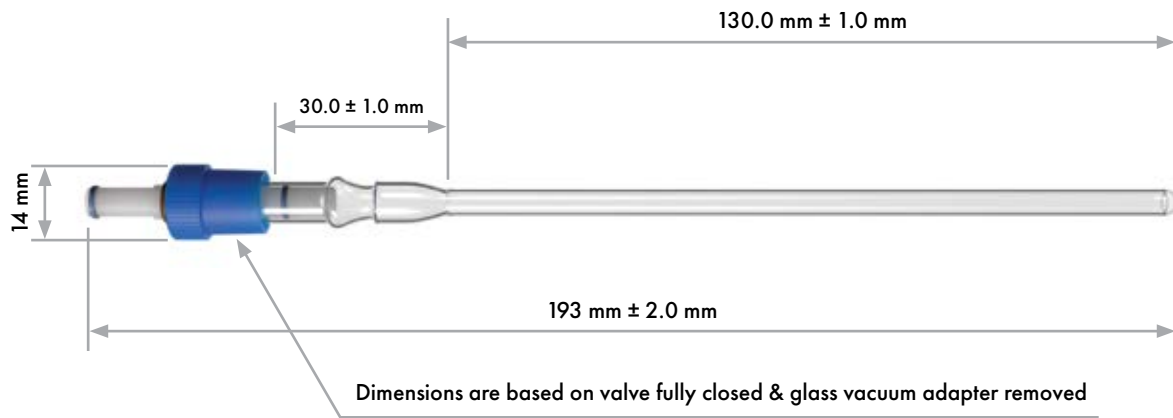

Norell® Valved NMR for Vacuum & Reduced Pressure fitted to spinner turbine



Our 133 mm NMR tube attached to a Norell® Pressure Valve will allow clearance for use in Automated Samplers.



Approx. 15 mm clearance between top of Valved NMR Tube and red height gauge.

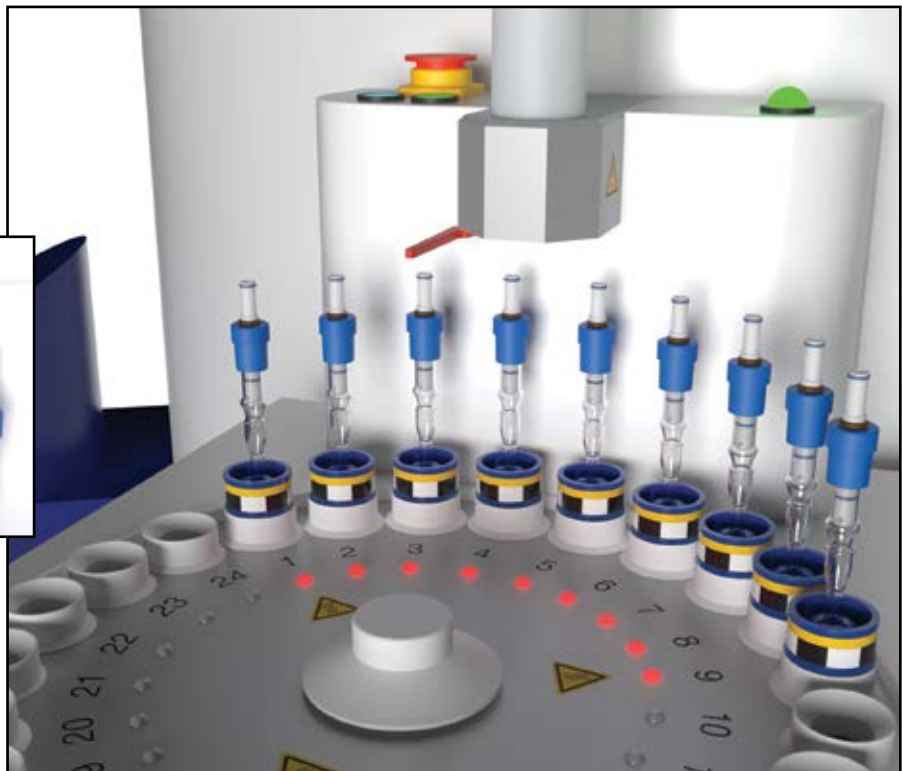

## Intermediate Pressure Valved NMR Sample Tubes

Norell, Inc. is pleased to introduce an NMR sample tube product line, featuring a glass/PTFE pressure valve permanently joined to your choice of a wide selection of available NMR sample tubes.

*This valve incorporates an advanced seal design that is superior to alternative valves currently available from other manufacturers. A fluoroelastomer o-ring imparts resilience and a high degree of chemical resistance. A PTFE sheath, forming the primary seal, completely covers the fluoroelastomer o-ring, creating the ultimate barrier against aggressive, reactive substances while providing a totally inert surface.*

These pressure tubes facilitate experiments requiring conditions such as pressurized inert atmosphere blanketing, addition of reactive gaseous reagents under pressure, containment of low boiling point solvents or samples at elevated temperatures, and so on.

We recommend that the maximum operating pressure should be limited to 600 kPa (6 bar, 87 psi) when using a thin wall pressure tube, up to 1200 kPa (12 bar, 175 psi) if using a heavy wall pressure tube. (Please see accompanying table for complete details).

**Cautionary Note:** Glass can be an unpredictable material, especially if it has been scratched or subjected to rough handling. As such, EXTREME CAUTION

should be exercised when using glass at elevated pressure or temperature, because it has the potential to fail suddenly and catastrophically. Therefore, anyone attempting to use glass components, such as NMR sample tubes at elevated or reduced pressures and/or temperatures should ensure that adequate personal protection, such as explosion shields, full face coverage shields, heavy gloves, etc., are employed to protect oneself against flying glass fragments if a glass component fails explosively.

The valve accepts 1/16 inch O.D. PTFE tubing, a common laboratory instrumentation pressure line. The required components, a 1/16 inch ferrule and matching compression nut, are included with the valve assembly. The valve easily and quickly connects and disconnects by means of the single compression nut.

All components of the valved pressure tube consist of either glass or polymer, as described in more detail below, allowing safe use in high magnetic field environments.

The sample tube portion, manufactured from ASTM Type I Class A glass (Pyrex® or an equivalent) tolerates a maximum temperature of about 230°C, and resists sudden temperature changes, or thermal shock, very well without breakage, but sudden temperature changes should be restricted to a range of 120°C or less.

## Intermediate Pressure Valved NMR Sample Tubes (Cont.)

The pressure valve portion possesses superior chemical and corrosion resistance. The glass shell, also formed from ASTM Type I Class A glass, matches that of the sample tube, thereby minimizing breakage of the joint caused by internal strain or thermal shock.

The valve stem, composed of PTFE fluoropolymer (polytetrafluoroethylene) is completely inert and resists virtually all solvents, reactive chemicals and reagents, and deterioration induced by corrosive conditions.

**NOW AVAILABLE FOR  
AUTOMATED SYSTEMS**

Custom NMR sample tube lengths for our Intermediate Pressure Valve now available for automated sampling systems.

The ferrule, or sealing nut (included with the valve), used to seal the pressure supply tubing to the valve, also displays excellent corrosion and chemical resistance. Constructed from ETFE (ethylene-tetrafluoroethylene) fluoropolymer, this material combines excellent mechanical properties, such as toughness, high impact strength, long flex life, medium stiffness, and good abrasion resistance with nearly the same level of chemical resistance shown by the fully fluorinated polymers such as PTFE.

The compression nut (also included with the valve) is machined from PEEK (polyether ether ketone). This material is an advanced, high-performance polymer having excellent mechanical properties, ensuring long life and reliable performance throughout numerous connecting and disconnecting operations. It is a very hard material, with a very high degree of tensile strength, stiffness, and dimensional stability, along with excellent chemical resistance.

3 NMR Tube Length Options  
203 mm, 178 mm or  
133 mm (for Automated Sampling)

*Due to the hand crafted nature of our pressure valves overall valve assembly length can vary slightly. A typical variance is 1-2 mm. Overall length is based on a fully seated operating cap.*

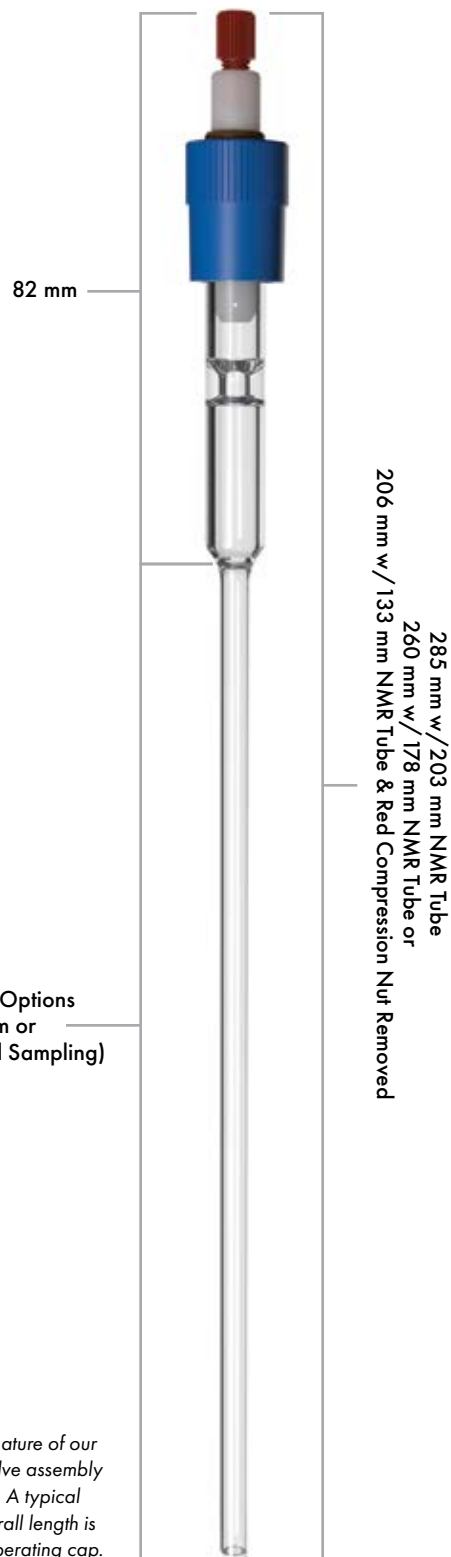

Available with **ULTRATHIN** wall NMR Tubes.

# SPECIAL PURPOSE SAMPLE TUBES

## 5 mm Intermediate Pressure Valved NMR Tubes

Item No.	MHz	Tube Length (mm)	I.D. mm (Volume $\mu\text{L}/\text{cm}$ )	Tube Wall	Recommended Maximum Operating Pressure		
					kPa	bar	psi
S-5-500-IPV-7	500	178	4.20 (138)	thin	600	6	87
S-5-500-MW-IPV-7	500	178	3.43 (92)	medium	900	9	130
S-5-500-HW-IPV-7	500	178	2.20 (38)	heavy	1200	12	175
S-5-500-IPV-8	500	203	4.20 (138)	thin	600	6	87
S-5-500-MW-IPV-8	500	203	3.43 (92)	medium	900	9	130
S-5-500-HW-IPV-8	500	203	2.20 (38)	heavy	1200	12	175
S-5-600-IPV-7	600	178	4.20 (138)	thin	600	6	87
S-5-600-MW-IPV-7	600	178	3.43 (92)	medium	900	9	130
S-5-600-HW-IPV-7	600	178	2.20 (38)	heavy	1200	12	175
S-5-600-IPV-8	600	203	4.20 (138)	thin	600	6	87
S-5-600-MW-IPV-8	600	203	3.43 (92)	medium	900	9	130
S-5-600-HW-IPV-8	600	203	2.20 (38)	heavy	1200	12	175
<b>Valved NMR for Automated Sampling</b>							
S-5-500-IPV-AS	500	133	4.20 (138)	thin	600	6	87
S-5-600-IPV-AS	600	133	4.20 (138)	thin	600	6	87
<b>ULTRATHIN Valved NMR</b>							
S-5-500-IPV-UTW-7	500	178	4.39 (144)	Ultra-Thin	500	5	73
S-5-500-IPV-UTW-8	500	203	4.39 (144)	Ultra-Thin	500	5	73
S-5-600-IPV-UTW-7	600	178	4.39 (144)	Ultra-Thin	500	5	73
S-5-600-IPV-UTW-8	600	203	4.39 (144)	Ultra-Thin	500	5	73
S-5-500-IPV-UTW-AS	500	133	4.39 (144)	Ultra-Thin	500	5	73
S-5-600-IPV-UTW-AS	600	133	4.39 (144)	Ultra-Thin	500	5	73

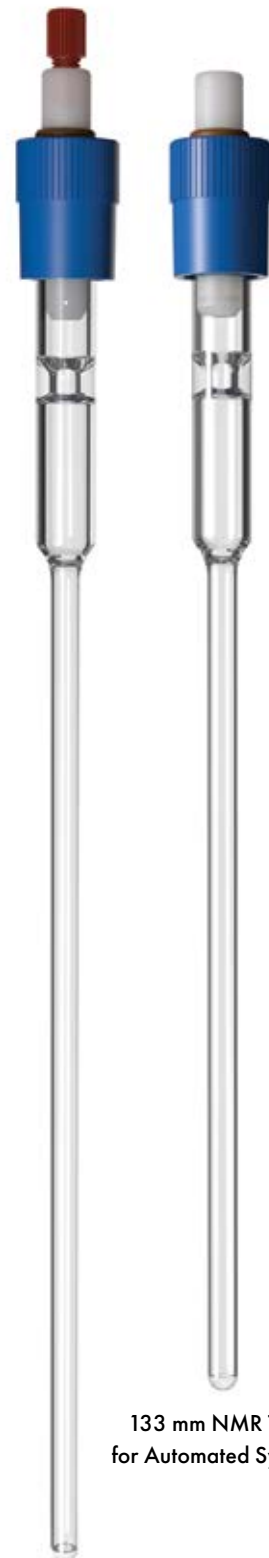

## 3 mm Intermediate Pressure Valved NMR Tubes

Item No.	MHz	Tube Length (mm)	I.D. mm (Volume $\mu\text{L}/\text{cm}$ )	Tube Wall	Recommended Maximum Operating Pressure		
					kPa	bar	psi
S-3-500-IPV-7	500	178	2.41 (46)	thin	860	8.6	125
S-3-500-IPV-8	500	203	2.41 (46)	thin	860	8.6	125
S-3-600-IPV-7	600	178	2.41 (46)	thin	860	8.6	125
S-3-600-IPV-8	600	203	2.41 (46)	thin	860	8.6	125
<b>Valved NMR for Automated Sampling</b>							
S-3-500-IPV-AS	500	133	2.41 (46)	thin	860	8.6	125
S-3-600-IPV-AS	600	133	2.41 (46)	thin	860	8.6	125



\* Fluoroelastomer O-Ring  
covered with PTFE Sheath

133 mm NMR Tube  
for Automated Systems

## Intermediate Pressure Valved NMR Sample Tubes (Cont.)

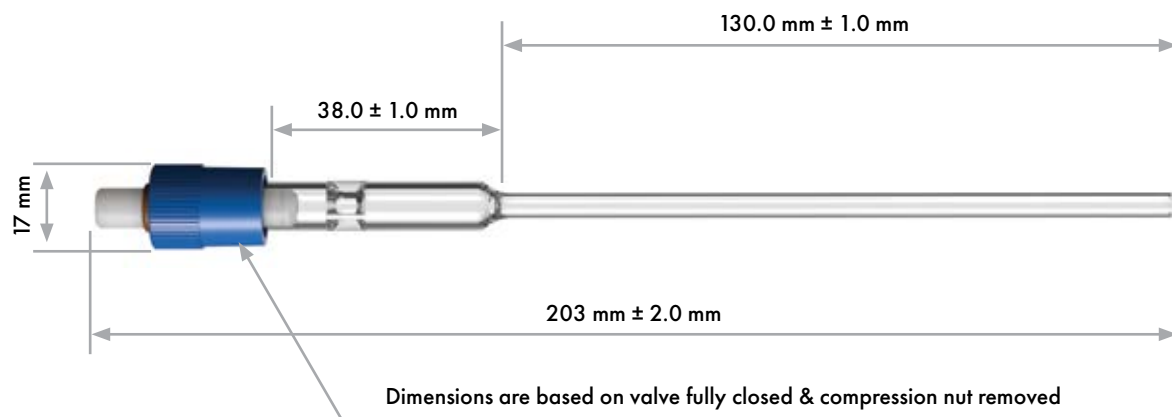

Norell® Valved NMR for Intermediate Pressure fitted to spinner turbine

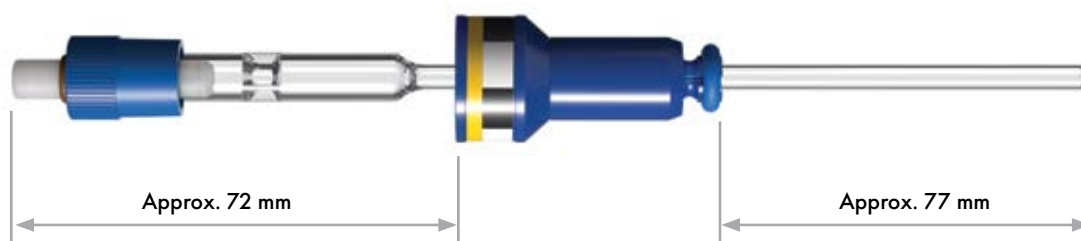

Our 133 mm NMR tube attached to a Norell® Pressure Valve will allow clearance for use in Automated Samplers.



Approx. 10 mm clearance between top of Valved NMR Tube and red height gauge.

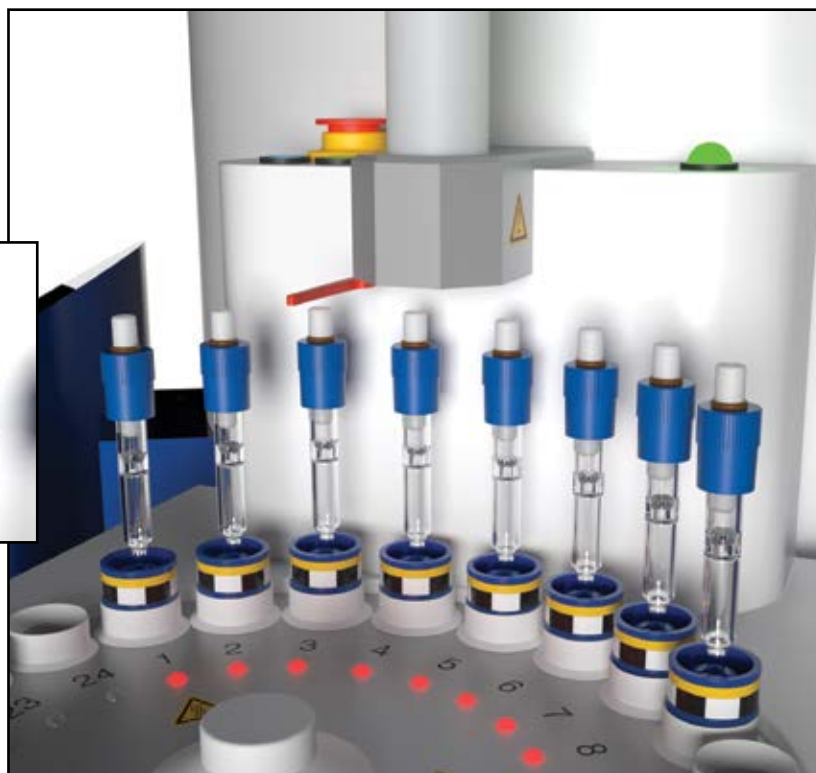

# SPECIAL PURPOSE SAMPLE TUBES

The IPV Valved NMR Sample Tubes for Intermediate Pressure are very useful for experiments requiring conditions such as pressurized inert atmosphere blanketing, addition of reactive gaseous reagents under pressure, containment of low boiling point solvents or samples at elevated temperatures, and similar applications.

The IPV Valved NMR tube quickly and easily connects to 1/16 inch (1.6 mm) OD PEEK or PTFE pressure tubing (a common size of laboratory instrumentation pressure line often found on HPLC and GC instruments) using the included 1/16 inch flat-bottom port ferrule and #10-32 threaded compression nut.

We recommend limiting the maximum operating pressure to 600 kPa (6 bar, 87 psi) for a 5 mm thin wall NMR tube, 900 kPa (9 bar, 130 psi) for a 5 mm medium wall NMR tube, or 1200 kPa (12 bar, 175 psi) for a 5 mm heavy wall NMR tube. (Additional information can be found on our website at: Valved NMR Sample Tubes for Intermediate Pressure from NORELL®).

Though the IPV Valved NMR Tube can be used under full vacuum, the small inner diameter of the 1/16 inch tubing used may cause a longer evacuation time to reach a high vacuum level.

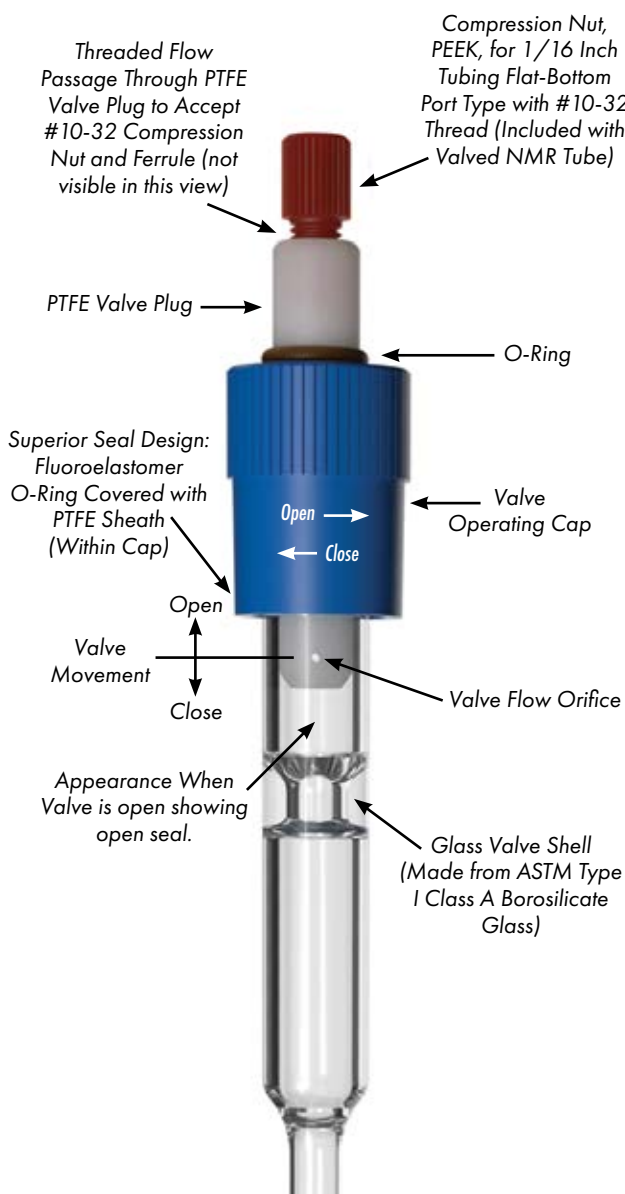

**1.** To make the connection to a pressure source, such as an argon or hydrogen gas cylinder, for example, one end of a short length of PEEK or PTFE pressure tubing of 1/16 inch OD (not supplied with the IPV Valved NMR Tube) must first be connected to the gas pressure regulator outlet, or other source of gas pressure. (Ensure that the regulated pressure is within the safe limits described above for the particular IPV Valved NMR Tube to be used, as well).

**2.** After this connection is made, the IPV Valved NMR Tube can be easily and quickly connected to the other end of the pressure tubing by slipping the compression nut onto the tubing, followed by the ferrule, oriented so that the tapered end of the ferrule faces into the threaded end of the compression nut, with the large flat end of the ferrule flush with the end of the tubing.

**3.** Insert the pressure tubing with the ferrule into the threaded opening of the white PTFE valve plug until the ferrule bottoms, then slide the compression nut over the tubing, into the white PTFE valve plug and turn the compression nut until the threads engage. Continue turning the compression nut gently until it begins to tighten upon reaching full depth, then finger tighten an additional 1/4 turn to fully compress the ferrule onto the pressure tubing. Lightly tug at the pressure tubing to be sure it is held firmly in place.

**4.** Gas pressure can now be applied to the IPV Valved NMR Tube. Turn the Valve Operating Cap counter-clockwise (CCW) to lift the white PTFE valve plug from its seated, closed position and open the valve, allowing gas to flow through the central axial passage of the PTFE valve plug, out through the Valve Flow Orifice, into the surrounding annular space of the glass valve shell and finally through the open valve into the interior of the NMR tube.

**5.** After the desired level of pressure has been reached, the IPV Valve can be closed by turning the Valve Operating Cap fully clockwise (CW) until the PTFE valve plug is tightly sealed, as shown by the white band of contact (Figure 1 at bottom), then close any additional valve(s) as necessary to the pressure source.

**6.** To disconnect the IPV Valved NMR Tube from the pressure supply, turn the compression nut counter-clockwise (CCW) until the compression nut, ferrule, and pressure line pull free, allowing the IPV Valved NMR Tube to be taken elsewhere as needed.

**7.** To disassemble the IPV Valved NMR Tube for cleaning, while working in a fume hood, slowly turn the Valve Operating Cap counter-clockwise (CCW) to release any residual pressure contained within, then continue turning the Valve Operating Cap until the threads disengage, allowing the white PTFE valve plug to be removed from the glass valve shell.



# EXTREME SERIES High Pressure Valved NMR Sample Tubes

Norell, Inc. is delighted to present the Extreme Series line of High Pressure Valved NMR Sample Tubes. The Extreme Series remains similar in function, use, and pressure capability to the traditional High Pressure Valved NMR Sample Tubes, but the PTFE fluoropolymer valve plug has been upgraded and improved by changes to the design of the o-ring seal.

The Extreme Series line consists of two categories: Level 1 and Level 3. Both levels incorporate a higher degree of valve seal integrity to guard against leakage or pressure loss due to o-ring failure caused by wear or other physical damage, and/or deterioration or damage caused by chemical exposure. Available with **ULTRATHIN** wall NMR Tubes.



## Base Protection: Level 1

Level 1 includes an additional standard fluoroelastomer o-ring seal to augment the existing fluoroelastomer o-ring, thus providing a secondary, backup o-ring if the primary one leaks or fails because of wear or physical damage.



## Ultimate Protection: Level 3

Level 3 incorporates additional chemical and solvent resistance over Level 1 and the traditional High Pressure Valved NMR Sample tubes, by the substitution of Kalrez® perfluoroelastomer o-ring(s) in place of the standard fluoroelastomer o-rings. Kalrez® perfluoroelastomer o-rings offer the ultimate level of physical and chemical resistance with the inclusion of a secondary, backup o-ring.

### Accessories for High Pressure Valved NMR Sample Tubes

Item Number	Description
HPV-1/8X1/8-UNION	Optional Union Adapter, Type 316 Stainless Steel, for 1/8" metallic double ferrule line termination



Union Adapter  
Sold Separately

# EXTREME SERIES High Pressure Valved NMR Sample Tubes

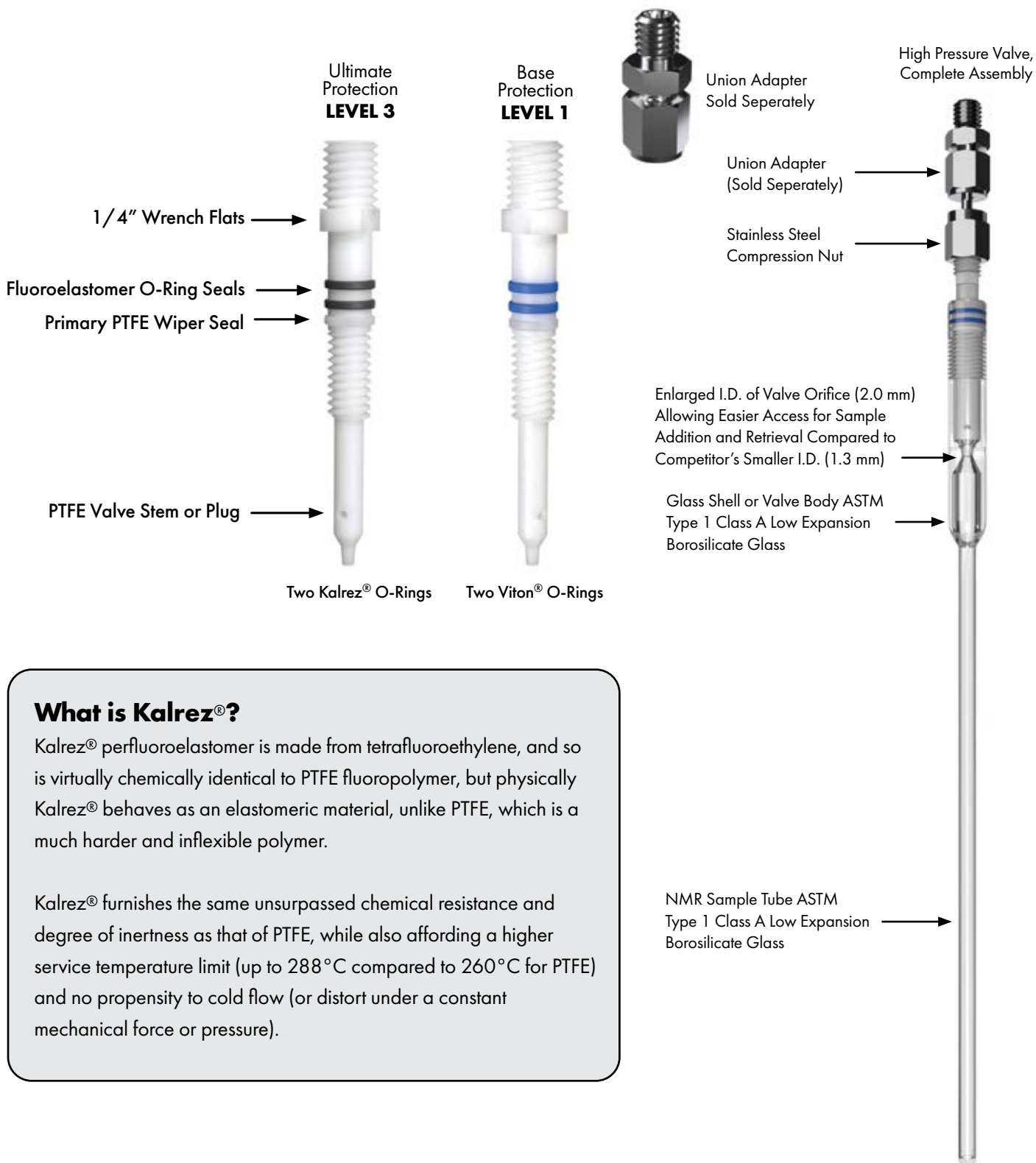

## What is Kalrez®?

Kalrez® perfluoroelastomer is made from tetrafluoroethylene, and so is virtually chemically identical to PTFE fluoropolymer, but physically Kalrez® behaves as an elastomeric material, unlike PTFE, which is a much harder and inflexible polymer.

Kalrez® furnishes the same unsurpassed chemical resistance and degree of inertness as that of PTFE, while also affording a higher service temperature limit (up to 288°C compared to 260°C for PTFE) and no propensity to cold flow (or distort under a constant mechanical force or pressure).

# SPECIAL PURPOSE SAMPLE TUBES

Due to the hand crafted nature of our pressure valves overall valve assembly length can vary slightly. A typical variance is 1-2 mm.

## EXTREME SERIES High Pressure Valved NMR Sample Tubes



### 3 mm Extreme Series Level 1

Item No.	MHz	Tube Length (mm)	I.D. mm (Volume $\mu\text{L}/\text{cm}$ )	Tube Wall	Recommended Maximum Operating Pressure		
					kPa	bar	psi
S-3-500-EX1-HPV-7	500	178	2.41 (46)	thin	960	9.6	140
S-3-500-EX1-HPV-8	500	203	2.41 (46)	thin	960	9.6	140
S-3-600-EX1-HPV-7	600	178	2.41 (46)	thin	960	9.6	140
S-3-600-EX1-HPV-8	600	203	2.41 (46)	thin	960	9.6	140

### 5 mm Extreme Series Level 1

Item No.	MHz	Tube Length (mm)	I.D. mm (Volume $\mu\text{L}/\text{cm}$ )	Tube Wall	Recommended Maximum Operating Pressure		
					kPa	bar	psi
S-5-500-EX1-HPV-7	500	178	4.20 (138)	thin	700	7	100
S-5-500-MW-EX1-HPV-7	500	178	3.43 (92)	medium	1050	10.5	150
S-5-500-HW-EX1-HPV-7	500	178	2.20 (38)	heavy	1400	14	200
S-5-500-EX1-HPV-8	500	203	4.20 (138)	thin	700	7	100
S-5-500-MW-EX1-HPV-8	500	203	3.43 (92)	medium	1050	10.5	150
S-5-500-HW-EX1-HPV-8	500	203	2.20 (38)	heavy	1400	14	200
S-5-600-EX1-HPV-7	600	178	4.20 (138)	thin	700	7	100
S-5-600-MW-EX1-HPV-7	600	178	3.43 (92)	medium	1050	10.5	150
S-5-600-HW-EX1-HPV-7	600	178	2.20 (38)	heavy	1400	14	200
S-5-600-EX1-HPV-8	600	203	4.20 (138)	thin	700	7	100
S-5-600-MW-EX1-HPV-8	600	203	3.43 (92)	medium	1050	10.5	150
S-5-600-HW-EX1-HPV-8	600	203	2.20 (38)	heavy	1400	14	200
S-5-800-EX1-HPV-7	800	178	4.20 (138)	thin	700	7	100
S-5-800-MW-EX1-HPV-7	800	178	3.43 (92)	medium	1050	10.5	150
S-5-800-HW-EX1-HPV-7	800	178	2.20 (38)	heavy	1400	14	200
S-5-800-EX1-HPV-8	800	203	4.20 (138)	thin	700	7	100
S-5-800-MW-EX1-HPV-8	800	203	3.43 (92)	medium	1050	10.5	150
S-5-800-HW-EX1-HPV-8	800	203	2.20 (38)	heavy	1400	14	200
<b>ULTRATHIN Valved NMR</b>							
S-5-500-HPV-EX1-UTW-7	500	178	4.39 (144)	Ultra-Thin	500	5	73
S-5-500-HPV-EX1-UTW-8	500	203	4.39 (144)	Ultra-Thin	500	5	73
S-5-600-HPV-EX1-UTW-7	600	178	4.39 (144)	Ultra-Thin	500	5	73
S-5-600-HPV-EX1-UTW-8	600	203	4.39 (144)	Ultra-Thin	500	5	73

113 mm

2 NMR Tube Length Options  
203 mm or 178 mm

315 mm w/ 203 mm NMR Tube or  
290 mm w/ 178 mm NMR Tube



# EXTREME SERIES

## High Pressure Valved NMR Sample Tubes

### 3 mm Extreme Series Level 3

Item No.	MHz	Tube Length (mm)	I.D. mm (Volume $\mu\text{L}/\text{cm}$ )	Tube Wall	Recommended Maximum Operating Pressure		
					kPa	bar	psi
S-3-500-EX3-HPV-7	500	178	2.41 (46)	thin	960	9.6	140
S-3-500-EX3-HPV-8	500	203	2.41 (46)	thin	960	9.6	140
S-3-600-EX3-HPV-7	600	178	2.41 (46)	thin	960	9.6	140
S-3-600-EX3-HPV-8	600	203	2.41 (46)	thin	960	9.6	140



### 5 mm Extreme Series Level 3

Item No.	MHz	Tube Length (mm)	I.D. mm (Volume $\mu\text{L}/\text{cm}$ )	Tube Wall	Recommended Maximum Operating Pressure		
					kPa	bar	psi
S-5-500-EX3-HPV-7	500	178	4.20 (138)	thin	700	7	100
S-5-500-MW-EX3-HPV-7	500	178	3.43 (92)	medium	1050	10.5	150
S-5-500-HW-EX3-HPV-7	500	178	2.20 (38)	heavy	1400	14	200
S-5-500-EX3-HPV-8	500	203	4.20 (138)	thin	700	7	100
S-5-500-MW-EX3-HPV-8	500	203	3.43 (92)	medium	1050	10.5	150
S-5-500-HW-EX3-HPV-8	500	203	2.20 (38)	heavy	1400	14	200
S-5-600-EX3-HPV-7	600	178	4.20 (138)	thin	700	7	100
S-5-600-MW-EX3-HPV-7	600	178	3.43 (92)	medium	1050	10.5	150
S-5-600-HW-EX3-HPV-7	600	178	2.20 (38)	heavy	1400	14	200
S-5-600-EX3-HPV-8	600	203	4.20 (138)	thin	700	7	100
S-5-600-MW-EX3-HPV-8	600	203	3.43 (92)	medium	1050	10.5	150
S-5-600-HW-EX3-HPV-8	600	203	2.20 (38)	heavy	1400	14	200
S-5-800-EX3-HPV-7	800	178	4.20 (138)	thin	700	7	100
S-5-800-MW-EX3-HPV-7	800	178	3.43 (92)	medium	1050	10.5	150
S-5-800-HW-EX3-HPV-7	800	178	2.20 (38)	heavy	1400	14	200
S-5-800-EX3-HPV-8	800	203	4.20 (138)	thin	700	7	100
S-5-800-MW-EX3-HPV-8	800	203	3.43 (92)	medium	1050	10.5	150
S-5-800-HW-EX3-HPV-8	800	203	2.20 (38)	heavy	1400	14	200
<b>ULTRATHIN Valved NMR</b>							
S-5-500-HPV-EX3-UTW-7	500	178	4.39 (144)	Ultra-Thin	500	5	73
S-5-500-HPV-EX3-UTW-8	500	203	4.39 (144)	Ultra-Thin	500	5	73
S-5-600-HPV-EX3-UTW-7	600	178	4.39 (144)	Ultra-Thin	500	5	73
S-5-600-HPV-EX3-UTW-8	600	203	4.39 (144)	Ultra-Thin	500	5	73

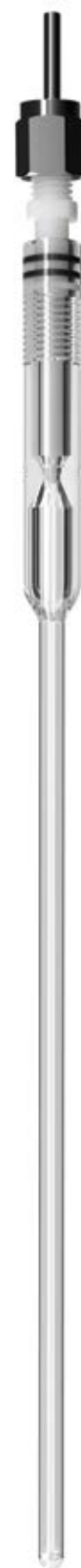

# SPECIAL PURPOSE SAMPLE TUBES

## Screw-Cap NMR Sample Tubes

These versatile tubes integrate secure screw-cap closure with septum sampling capability, enabling material addition or removal without tube opening. Each tube features a PTFE-sealed closure system that provides reliable containment with convenient access.

Complete assembly includes an open-top polypropylene screw cap with PTFE/silicone septum, optimized for clean, reliable penetration using standard 22-gauge needles.

- **Complete closure system:** open-top polypropylene screw cap with PTFE/silicone septum
- **Chemical compatibility:** inert to most organic solvents and compounds (not suitable for strongly corrosive materials)
- **Usage limitation:** designed for single or limited puncture applications

Item No.	MHz	Length (in)
S-5-500-SC-7	500	7
S-5-500-SC-8	500	8
S-5-600-SC-7	600	7
S-5-600-SC-8	600	8

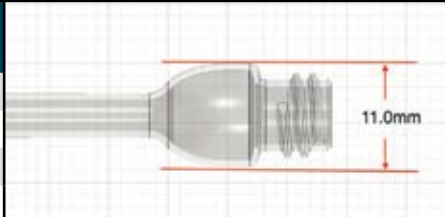

Now available in **Ultra-Thin** wall, call **1-800-828-584-2600** or visit [www.nmrtubes.com/nmr-epr-tubes/secure-series](http://www.nmrtubes.com/nmr-epr-tubes/secure-series) to access our custom quote form.

## Screw-Cap NMR Tube Caps

These versatile caps combine secure screw-cap closure with septum sampling capability, allowing material addition or removal without opening the tube. Each cap includes a PTFE-backed silicone septum optimized for clean, reliable access using standard 22-gauge needles.

**Available in two configurations:** septum caps for sampling applications, or solid polypropylene caps with PTFE liner for permanent sealing. Both styles are compatible with 5 mm and 10 mm screw-cap NMR sample tubes.

Item No.	Description	Thread	Packed In Lots Of
S-5-SC	Screw-Cap Tube Cap with Septum, Compatible with 5 mm or 10 mm Screw-Cap NMR Sample Tubes	8-425	12
S-5-SSC	Solid Screw-Cap Tube Cap No Septum, Compatible with 5 mm or 10 mm Screw-Cap NMR Sample Tubes	8-425	12



S-5-SC  
(screw cap with septum, compatible with 5 mm & 10 mm screw-cap NMR sample tubes)



S-5-SSC  
(screw cap without septum, compatible with 5 mm & 10 mm screw-cap NMR sample tubes)

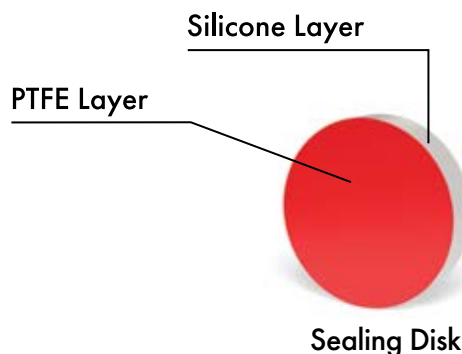

## Bruker Microbore NMR Sample Tubes

These ultra-precision NMR tubes are specifically engineered for Bruker's microprobes, delivering superior reliability and reproducibility compared to competitive products. Each tube features a precision-machined smaller diameter lower stem (available in multiple sizes as shown in the accompanying table) integrated with our high-precision 800 MHz-rated 5 mm Select Series™ tube body. This design maintains exceptional performance even under severe temperature gradients, ensuring consistent data integrity through our rigorous manufacturing standards.



Item No.	Stem O.D. (mm)	Stem I.D. (mm)	Stem Length (mm)	Overall Length (mm)	Capillary Volume (μl)
BMT-S-5-800-8-W/1.0 mm Stem	1.0 ± 0.025	0.58 ± 0.013	50	203	13
BMT-S-5-800-8-W/1.7 mm Stem	1.7 ± 0.025	1.3 ± 0.013	50	203	65
BMT-S-5-800-8-W/2.0 mm Stem	2.0 ± 0.025	1.6 ± 0.013	50	203	100
BMT-S-5-800-8-W/2.5 mm Stem	2.5 ± 0.025	2.1 ± 0.013	50	203	175
BMT-S-5-800-8-W/3.0 mm Stem	3.0 ± 0.025	2.41 ± 0.013	50	203	215

## High-Throughput NMR Sample Tubes

These economical tubes are specifically designed to minimize salt effects in buffered biological samples while delivering the high precision required for today's high-field spectrometers. Manufactured from ASTM Type I Class A borosilicate glass, they provide consistent reproducibility and durability for routine NMR applications.

Optimized for single-use workflows, these tubes deliver reliable performance that matches or exceeds more expensive alternatives, making them ideal for laboratories requiring both quality and cost efficiency. Available in convenient 25-tube packs. Recommended for use with our Optimizer Inserts™, see pages 56 and 57.



Item No.	O.D. (mm)	I.D. (mm)	Concentricity (mm)	Camber ± (mm)	Length (mm)	Packed In Lots Of
S-3-HT-7	2.99 ± 0.030	2.41 ± 0.030	0.011	0.040	178	25
S-3-HT-8	2.99 ± 0.030	2.41 ± 0.030	0.011	0.040	203	25
S-4-HT-7	3.99 ± 0.030	3.20 ± 0.030	0.011	0.040	178	25
S-4-HT-8	3.99 ± 0.030	3.20 ± 0.030	0.011	0.040	203	25
S-4.25-HT-7	4.24 ± 0.030	3.34 ± 0.030	0.011	0.040	178	25
S-4.25-HT-8	4.24 ± 0.030	3.34 ± 0.030	0.011	0.040	203	25

Now available in **Ultra-Thin** wall, call **1-800-828-584-2600** or visit [www.nmrtubes.com/nmr-epr-tubes/high-throughput-nmr-sample-tubes](http://www.nmrtubes.com/nmr-epr-tubes/high-throughput-nmr-sample-tubes) to access our custom quote form.

Pictured with optional NorLoc™ Cap. Microbore & High-Throughput NMR Sample Tubes ship with economy caps.

# SPECIAL PURPOSE SAMPLE TUBES

## Amberized NMR Sample Tubes

Amberized NMR tubes protect photosensitive materials from visible and ultraviolet radiation. These tubes provide optical transmittance values ranging from 0% to 50% in the 650 nm to 300 nm range (covering the visible spectrum), while virtually blocking all UV radiation from 300 nm to 190 nm due to glass's inherent opacity to UV light.

Most borosilicate glass NMR tubes can be amberized, including all tubes from 3 mm to 10 mm O.D. in our Select Series™ and Standard Series™ product lines. Special purpose tubes also amberize readily, including valved tubes (with vacuum & reduced pressure, intermediate pressure, or high pressure assemblies), screw-cap tubes, constricted tubes, and medium or heavy wall configurations.

The amber coloration results from a high-temperature process that exchanges metal atoms within the glass structure, creating a permanent tint that resists chemicals, solvents, and physical abrasion. However, subsequent high-temperature operations such as glassblowing can weaken or eliminate the amber color.

Quartz NMR and EPR tubes cannot be amberized because they consist of pure silica without the metallic elements required for the amberizing process.

Available with **ULTRATHIN** wall NMR Tubes.



### Ordering Information

To order an item to be amberized, please state "Amberized" after the desired Item Number or in the product description. Please note that amberizing will incur an additional charge.

## Constricted NMR Sample Tubes

Constricted NMR tubes offer a convenient way to seal your sample from air or other contaminants. To seal, simply heat the constricted portion using a suitable heat source (e.g., a small butane torch), then gently twist and pull the open end to create a permanent seal. This design also allows samples to be stored under vacuum or inert gas atmospheres.

**Please note:** Constricted tubes are specified and ordered by their required finished length (measured from the tube bottom to the center of the constriction), as shown in the table below.



OD of NMR Tube (mm)	ID at Constriction (mm)	Finished Length (After Sealing, mm)	Overall Length (Before Sealing, mm)
3 – 10	1.5 – 2.0	178 nominal	203 ± 2.0
3 – 10	1.5 – 2.0	203 nominal	228 ± 2.0

5 mm & 10 mm NMR Tubes available with **ULTRATHIN** wall.

Pictured with optional NorLoc™ Cap. Constricted & Amberized NMR Sample Tubes ship with economy caps.

## Heavy Wall NMR Sample Tubes

These robust tubes feature 1.4 mm wall thickness for maximum protection against breakage from thermal shock, pressure changes, or mechanical stress. The enhanced wall construction provides critical sample containment for hazardous or radioactive materials where tube failure cannot be tolerated.

Available with optional constricted designs for flame sealing and/or amberized glass for light-sensitive samples.

Item No.	MHz	O.D. (mm)	I.D. (mm)	Wall (mm)	Length (mm)	Packed In Lots of
S-5-500-HW-7	up to 500	4.97 ± 0.013	2.20 ± 0.025	1.4	178	5
S-5-500-HW-8	up to 500	4.97 ± 0.013	2.20 ± 0.025	1.4	203	5
S-5-500-HW-9	up to 500	4.97 ± 0.013	2.20 ± 0.025	1.4	228.6	5



S-5-500-HW-7

## Medium Wall NMR Sample Tubes

These reinforced tubes feature 0.8 mm wall thickness, providing enhanced protection against breakage while maintaining 65% of standard sample volume. The balanced design offers improved durability for educational environments and automated sampling systems where handling frequency increases breakage risk.

Available with optional constricted designs for flame sealing and/or amberized glass for light-sensitive samples.

Item No.	MHz	O.D. (mm)	I.D. (mm)	Wall (mm)	Length (mm)	Packed In Lots of
S-5-500-MW-7	up to 500	4.97 ± 0.013	3.43 ± 0.025	0.8	178	5
S-5-500-MW-8	up to 500	4.97 ± 0.013	3.43 ± 0.025	0.8	203	5
S-5-500-MW-9	up to 500	4.97 ± 0.013	3.43 ± 0.025	0.8	228.6	5



S-5-500-MW-7

# SPECIAL PURPOSE SAMPLE TUBES

## Bruker MATCH™ System NMR Sample Tubes

These ultra-precision machined tubes are specifically engineered for the Bruker MATCH™ System, offering eight different outer diameters to optimize sample volume for various applications. Each tube size features color-coded caps for quick identification and workflow efficiency.

**The tube selection enables optimal probe matching:** 3.0 mm to 5.0 mm O.D. tubes for 5 mm RT probes, and 1.0 mm to 3.0 mm O.D. tubes for 3 mm cryo-probes. **Note:** 1.0 mm tubes are not compatible with dedicated 1 mm Bruker probes.

Item No.	O.D. (mm)	I.D. (mm)	Length (mm)	Sample Volume (µl) *	Packed In Lots of
S-1.0-500-1	1.00 +0.010 -0.025	0.58 ± 0.010	100 mm	12	5
S-1-0.73-500-1	1.00 +0.010 -0.025	0.73 ± 0.010	100 mm	19	5
S-1.7-500-1	1.70 +0.010 -0.025	1.30 ± 0.010	100 mm	45	5
S-2.0-500-1	2.00 +0.010 -0.025	1.60 ± 0.010	100 mm	70	5
S-2.5-500-1	2.50 +0.010 -0.025	2.10 ± 0.010	100 mm	120	5
S-3.0-500-1	2.99 +0.010 -0.025	2.41 ± 0.010	100 mm	160	5
S-4.0-500-1	3.99 +0.010 -0.025	3.20 ± 0.010	100 mm	310	5
S-4.25-500-1	4.25 +0.010 -0.025	3.43 ± 0.010	100 mm	370	5
S-5.0-500-1	4.97 +0.010 -0.025	4.20 ± 0.010	100 mm	490	5

\* Sample volume recommendations per Bruker Biospin™ specifications.

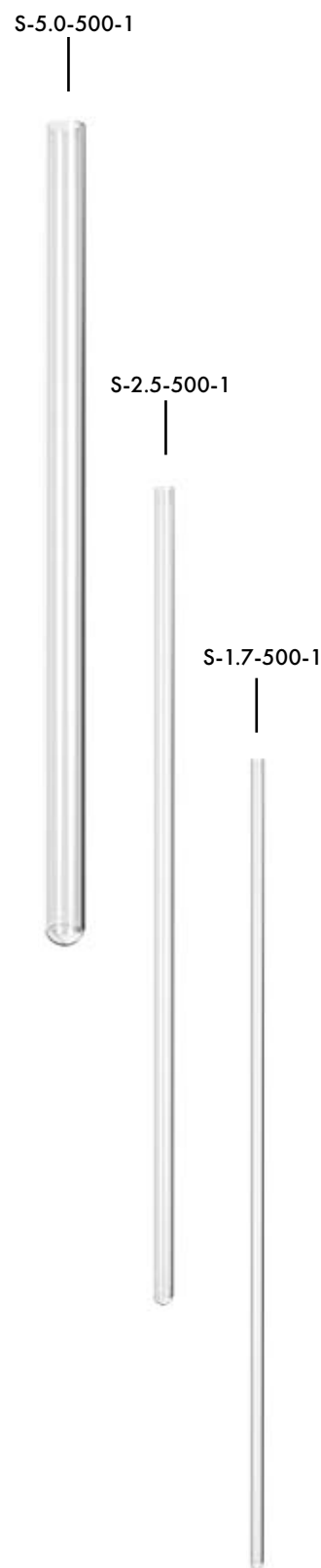

## Tapered Fluoropolymer Caps for Bruker MATCH™ Tubes

These precision-machined PTFE fluoropolymer caps feature color-coding that corresponds to both tube size and MATCH™ Insert Assembly clamp colors, enabling rapid component identification and system setup.

**The caps incorporate a progressive taper design:** initial alignment allows easy installation, while progressive tightening at full insertion depth creates a positive seal. This engineered fit preserves volatile sample solutions during both short-term and extended storage periods.

Complete compatibility includes caps for all current MATCH™ tube sizes plus legacy 1.0 mm O.D. tubes from earlier kit versions.

Cap Item No.	Tube Item No.	Color	Packed In Lots of
TCM100	S-1.0-500-1	Black	5
TCM170	S-1.7-500-1	Natural	5
TCM200	S-2.0-500-1	Yellow	5
TCM250	S-2.5-500-1	Red	5
TCM300	S-3.0-500-1	Green	5
TCM400	S-4.0-500-1	Blue	5
TCM425	S-4.25-500-1	Natural	5
TCM500	S-5.0-500-1	Black	5



Tapered Fluoropolymer Caps

# FLUOROPOLYMER TUBING

## Thin-Wall Transparent Fluoropolymer FEP Tubing

This thin-wall transparent tubing is manufactured from virgin-grade DuPont FEP thermoplastic fluoropolymer. Unlike PTFE, FEP offers heat-sealing capability, enabling custom packaging and storage solutions for corrosive materials, liquids, and solids.

The flexible tubing provides tight conformance over glass or metal components where secure fitting is critical. Each package contains four 305 mm (12") sections for convenient handling and storage.

Product designation: The number following "TWT" indicates the internal diameter in millimeters (e.g., TWT-5 = 5 mm I.D.).

Item No.	O.D. (mm)	I.D. (mm)	Length (mm)	Packed In Lots Of
TWT-3	3.52	3	305	4
TWT-4	4.91	4	305	4
TWT-5	5.60	5	305	4
TWT-6	6.55	6	305	4
TWT-7	7.68	7	305	4
TWT-8	8.54	8	305	4
TWT-9	9.55	9	305	4
TWT-10	10.63	10	305	4
TWT-12	12.78	12	305	4
TWT-312	(3-12 mm inside diameter)*		305	1 set

\* This package contains 1 of each size 3 mm through 12 mm (9tubes)



## PTFE Tubing (PolyTetraFluoroEthylene)

PTFE tubing provides exceptional performance for applications requiring temperatures up to 260°C (500°F). Its superior thermal stability resists melt-off during soldering operations, while excellent dielectric properties make it ideal for electronics and electrical applications. The non-stick surface characteristics enable fluid transport with minimal resistance.

### Chemical Compatibility

PTFE offers outstanding chemical resistance to virtually all industrial solvents, chemicals, and corrosive materials. Notable exceptions include fluorine, molten sodium hydroxide, and molten alkali metals.



### Performance Advantages

Our extruded PTFE tubing outperforms glass and graphite alternatives through superior chemical resistivity and low coefficient of friction, making it optimal for critical fluid transfer applications. The material maintains dimensional stability under elevated temperature processing and can be steam sterilized without affecting physical properties including surface hardness, elongation, flex life, or deformation under load.

### Available Configurations

Standard tubing appears translucent white (degree of opacity varies with wall thickness and manufacturing lot). Colored tubing is available to simplify system routing and identification during installation. Custom designs available upon request.

### PTFE Fractional Sizes

O.D. (in)	I.D. (in)	Wall (in)	Nominal O.D.	O.D. Tolerance (in)	Wall Tolerance (in)	Working Pressure PSIG (bar)	Burst Pressure PSIG (bar)	Minimum Bend Radius (in)
1/8	1/16	0.031	0.125	+/- 0.004	+/- 0.003	300 (21)	1500 (103)	1/2
3/16	1/8	0.031	0.188	+/- 0.005	+/- 0.003	192 (13)	961 (66)	1/2
1/4	3/16	0.031	0.25	+/- 0.005	+/- 0.003	140 (9.7)	700 (48)	1
1/4	5/32	0.047	0.25	+/- 0.005	+/- 0.003	219 (15)	1095 (75)	3/4
1/4	1/8	0.062	0.25	+/- 0.005	+/- 0.003	300 (21)	1500 (103)	1/2
5/16	1/4	0.031	0.313	+/- 0.005	+/- 0.003	110 (7.6)	549 (38)	3/4
5/16	3/16	0.062	0.313	+/- 0.005	+/- 0.003	235 (16)	1176 (81)	1/2
3/8	5/16	0.031	0.375	+/- 0.005	+/- 0.003	90 (6.2)	450 (31)	2-1/2
3/8	1/4	0.062	0.375	+/- 0.005	+/- 0.003	192 (13)	962 (66)	1
1/2	7/16	0.031	0.5	+/- 0.006	+/- 0.003	66 (4.6)	332 (23)	4
1/2	3/8	0.062	0.5	+/- 0.006	+/- 0.003	140 (9.7)	700 (48)	2

## PVDF Tubing (Polyvinylidene Fluoride)

PVDF tubing is a high-performance fluoropolymer engineered for demanding applications requiring exceptional chemical resistance, mechanical durability, and contamination-free operation. Also known by the trade name KYNAR<sup>®</sup>, this material delivers superior performance characteristics for critical fluid handling systems.

### Performance Characteristics

- Exceptional abrasion and cut-through resistance for extended service life
- Superior resistance to creep, fatigue, and mechanical stress
- Low permeability for reliable containment and minimal diffusion
- Broad chemical resistance across industrial solvents and reagents
- Excellent thermal stability for elevated temperature applications
- Outstanding radiation resistance for specialized environments

### Applications

PVDF tubing serves critical roles across diverse industries including aerospace and transportation technology, electronics components and insulators, chemical and pharmaceutical manufacturing, food processing, and environmental sciences. Its purity specifications make it ideal for air sampling systems, precision fluid transfer devices, water processing systems, and groundwater monitoring where contamination cannot be tolerated.

### Key Benefits

The combination of mechanical strength, chemical inertness, and purity makes PVDF tubing an optimal choice for protective lining, barrier applications, and ultrapure system components where reliability and performance are essential.

## PVDF Industrial Wall Fractional Sizes

O.D. (in)	I.D. (in)	Wall (in)	Nominal O.D.	O.D. Tolerance (in)	Wall Tolerance (in)	Working Pressure PSIG (bar)	Burst Pressure PSIG (bar)	Minimum Bend Radius (in)
1/8	1/16	0.031	0.125	+/- 0.004	+/- 0.003	600 (41)	3000 (207)	1/2
3/16	1/8	0.031	0.188	+/- 0.005	+/- 0.003	385 (27)	1923 (133)	1/2
1/4	3/16	0.031	0.25	+/- 0.005	+/- 0.003	280 (19)	1400 (97)	1
5/16	1/4	0.031	0.312	+/- 0.005	+/- 0.003	220 (15)	1098 (76)	1-3/4
3/8	5/16	0.031	0.375	+/- 0.005	+/- 0.003	180 (12)	902 (62)	2-1/2

## PVDF Heavy Wall Fractional Sizes

O.D. (in)	I.D. (in)	Wall (in)	Nominal O.D.	O.D. Tolerance (in)	Wall Tolerance (in)	Working Pressure PSIG (bar)	Burst Pressure PSIG (bar)	Minimum Bend Radius (in)
1/4	5/32	0.047	0.25	+/- 0.005	+/- 0.003	438 (30)	2191 (151)	3/4
1/4	1/8	0.062	0.25	+/- 0.005	+/- 0.003	600 (41)	3000 (207)	1/2
3/8	1/4	0.062	0.375	+/- 0.005	+/- 0.003	385 (27)	1923 (133)	3/4
1/2	3/8	0.062	0.5	+/- 0.005	+/- 0.003	280 (19)	1400 (97)	2-1/2
5/8	1/2	0.062	0.625	+/- 0.006	+/- 0.003	220 (15)	1098 (76)	3
3/4	5/8	0.062	0.75	+/- 0.006	+/- 0.003	180 (12)	902 (62)	6
1	7/8	0.062	1	+/- 0.010	+/- 0.003	133 (9)	664 (46)	16

## PVDF Metric Sizes

O.D. (mm)	I.D. (mm)	O.D./I.D. Tolerance (mm)	O.D. (in)	I.D. (in)	O.D./I.D. Tolerance (mm)	Working Pressure PSIG (bar)	Burst Pressure PSIG (bar)	Minimum Bend Radius (in)
4	2	+/- 0.11	0.157	0.078	+/- 0.004	600 (41)	3000 (207)	1/2
6	4	+/- 0.13	0.236	0.157	+/- 0.005	385 (27)	1923 (133)	1/2
8	6	+/- 0.13	0.315	0.236	+/- 0.005	280 (19)	1400 (97)	1-3/4
10	8	+/- 0.13	0.393	0.315	+/- 0.005	220 (15)	1098 (76)	2-1/2
12	10	+/- 0.15	0.472	0.393	+/- 0.006	180 (12)	902 (62)	3-1/2

## FEP Tubing (Fluorinated Ethylene Propylene)

FEP tubing is the preferred fluoropolymer for continuous-length small diameter applications, offering an optimal balance of performance and economy. While maximum service temperature is limited to 204°C (400°F), FEP delivers chemical and dielectric properties comparable to PTFE with superior optical clarity and processing characteristics.

### Performance Characteristics

- Exceptional optical clarity ideal for sight glass and flow monitoring applications
- Chemical inertness to most industrial chemicals and solvents
- Non-flammable with high thermal stability
- Superior gas and vapor permeability control
- Excellent UV transmission properties
- Enhanced processability for complex geometries

### Available Configurations

Standard and custom diameters available in straight lengths, coiled configurations, convoluted designs, and heat-shrink constructions. Multiple colors available to meet specific identification and routing requirements.

### Applications

FEP tubing serves critical functions across aerospace and transportation technology, electronics components and insulators, chemical and pharmaceutical manufacturing, food processing, and environmental sciences. Its clarity and chemical resistance make it ideal for air sampling systems, precision fluid transfer devices, water processing systems, and applications requiring visual flow confirmation.

### Key Advantages

Compared to PTFE, FEP offers superior transparency, better gas permeability control, and enhanced fabrication flexibility, making it the economical choice for applications requiring chemical resistance with visual monitoring capabilities.

## FEP Fractional Sizes

O.D. (in)	I.D. (in)	Wall (in)	Nominal O.D.	O.D. Tolerance (in)	Wall Tolerance (in)	Working Pressure PSIG (bar)	Burst Pressure PSIG (bar)	Minimum Bend Radius (in)
3/32	1/32	0.031	0.094	+/- 0.004	+/- 0.003	480 (33)	2400(165)	1/2
1/8	1/16	0.031	0.125	+/- 0.004	+/- 0.003	360 (25)	1800 (124)	1/2
5/32	3/32	0.031	0.157	+/- 0.005	+/- 0.003	282 (19)	1412 (97)	1/2
3/16	1/8	0.031	0.188	+/- 0.005	+/- 0.003	231 (16)	1154 (80)	1/2
3/16	1/16	0.062	0.188	+/- 0.005	+/- 0.003	480 (33)	2400 (165)	1/2
1/4	3/16	0.031	0.250	+/- 0.005	+/- 0.003	168 (11.6)	840 (58)	1
1/4	5/32	0.047	0.250	+/- 0.005	+/- 0.003	263 (18)	1315 (91)	3/4
1/4	1/8	0.062	0.250	+/- 0.005	+/- 0.003	360 (24.8)	1800 (124)	1/2
5/16	1/4	0.031	0.313	+/- 0.005	+/- 0.003	132 (9.1)	359 (24.8)	3/4
5/16	3/16	0.062	0.313	+/- 0.005	+/- 0.003	282 (19.4)	1412 (97.4)	1/2
3/8	5/16	0.031	0.375	+/- 0.005	+/- 0.003	109 (7.5)	541 (37.3)	2-1/2
3/8	1/4	0.062	0.375	+/- 0.005	+/- 0.003	231 (15.9)	1154 (79.6)	1
7/16	3/8	0.031	0.438	+/- 0.005	+/- 0.003	92 (6.3)	459 (31.6)	8
7/16	5/16	0.062	0.438	+/- 0.005	+/- 0.003	195 (13.4)	973 (67.1)	12
1/2	7/16	0.031	0.500	+/- 0.006	+/- 0.003	80 (5.5)	398 (27.4)	4
1/2	3/8	0.062	0.500	+/- 0.006	+/- 0.003	168 (11.6)	840 (57.9)	2
9/16	1/2	0.031	0.562	+/- 0.006	+/- 0.003	70.3 (4.8)	352 (24.3)	4-1/2
5/8	9/16	0.031	0.625	+/- 0.006	+/- 0.003	63 (4.3)	315 (21.7)	5-1/2
5/8	1/2	0.062	0.625	+/- 0.006	+/- 0.003	132 (9.1)	659 (45.4)	3
11/16	5/8	0.031	0.688	+/- 0.006	+/- 0.003	57 (3.9)	285 (19.7)	4
3/4	11/16	0.031	0.750	+/- 0.006	+/- 0.003	52 (3.6)	260 (17.9)	8
3/4	5/8	0.062	0.750	+/- 0.006	+/- 0.003	108 (7.4)	541 (37.3)	6
7/8	3/4	0.062	0.875	+/- 0.007	+/- 0.003	92 (6.3)	459 (31.6)	12
1	7/8	0.062	1.000	+/- 0.010	+/- 0.003	80 (5.5)	398 (27.4)	16
1.1	1	0.040	1.100	+/- 0.010	+/- 0.004	57 (3.9)	285 (19.7)	
1-1/8	1	0.062	1.125	+/- 0.015	+/- 0.003	70 (4.8)	352 (24.3)	
1-1/4	1-1/8	0.062	1.250	+/- 0.015	+/- 0.004	63 (4.3)	315 (21.7)	
1-3/8	1-1/4	0.040	1.375	+/- 0.015	+/- 0.004	57 (3.9)	285 (19.7)	

## **PFA Tubing (Perfluoroalkoxy)**

PFA tubing represents the premium fluoropolymer solution, combining the chemical inertness of PTFE with enhanced mechanical properties and processing advantages. Engineered for the most demanding applications, PFA delivers exceptional crack and stress resistance while maintaining superior performance at elevated temperatures up to 260°C (500°F).

### **Performance Characteristics**

- Superior thermal stability exceeding FEP capabilities
- Enhanced flexibility and long flex-life under thermal cycling
- Lower permeability than FEP for improved containment
- Translucent construction enabling visual flow monitoring
- Non-flammable with exceptional chemical resistance
- Near-zero moisture absorption for dimensional stability
- Maintains mechanical strength at maximum service temperatures

### **High Purity Grade**

PFA HP (High Purity) tubing offers ultra-low chemical extractables for semiconductor and pharmaceutical fluid handling applications where contamination control is critical.

### **Available Configurations**

Standard and custom diameters available in straight lengths, coiled hose constructions, and convoluted designs. Compatible with flare and conventional fittings for versatile system integration. FDA compliant for food contact applications.

### **Applications**

PFA tubing serves the most demanding applications in semiconductor processing, pharmaceutical manufacturing, chemical processing, and high-temperature fluid transfer systems where the combination of extreme chemical resistance, thermal stability, and mechanical durability is essential.

### **Key Advantages**

PFA uniquely combines PTFE's chemical inertness with FEP's clarity and processing benefits, while delivering superior mechanical properties and higher temperature capability, making it the optimal choice for critical high-performance applications.

## PFA Fractional Sizes

O.D. (in)	I.D. (in)	Wall (in)	Nominal O.D. (in)	O.D. Tolerance (in)	Wall Tolerance (in)	Working Pressure PSIG (bar)	Burst Pressure PSIG (bar)	Minimum Bend Radius (in)
3/32	1/32	0.031	0.094	+/- 0.004	+/- 0.003	480 (33)	2400(165)	1/2
1/8	1/16	0.031	0.125	+/- 0.004	+/- 0.003	360 (25)	1800 (124)	1/2
5/32	3/32	0.031	0.157	+/- 0.005	+/- 0.003	282 (19)	1412 (97)	1/2
3/16	1/8	0.031	0.188	+/- 0.005	+/- 0.003	231 (16)	1154 (80)	1/2
3/16	1/16	0.062	0.188	+/- 0.005	+/- 0.003	480 (33)	2400 (165)	1/2
1/4	3/16	0.031	0.250	+/- 0.005	+/- 0.003	168 (11.6)	840 (58)	1
1/4	5/32	0.047	0.250	+/- 0.005	+/- 0.003	263 (18)	1315 (91)	3/4
1/4	1/8	0.062	0.250	+/- 0.005	+/- 0.003	360 (24.8)	1800 (124)	1/2
5/16	1/4	0.031	0.313	+/- 0.005	+/- 0.003	132 (9.1)	359 (24.8)	3/4
5/16	3/16	0.062	0.313	+/- 0.005	+/- 0.003	282 (19.4)	1412 (97.4)	1/2
3/8	5/16	0.031	0.375	+/- 0.005	+/- 0.003	109 (7.5)	541 (37.3)	2-1/2
3/8	1/4	0.062	0.375	+/- 0.005	+/- 0.003	231 (15.9)	1154 (79.6)	1
7/16	3/8	0.031	0.438	+/- 0.005	+/- 0.003	92 (6.3)	459 (31.6)	8
7/16	5/16	0.062	0.438	+/- 0.005	+/- 0.003	195 (13.4)	973 (67.1)	12
1/2	7/16	0.031	0.500	+/- 0.006	+/- 0.003	80 (5.5)	398 (27.4)	4
1/2	3/8	0.062	0.500	+/- 0.006	+/- 0.003	168 (11.6)	840 (57.9)	2
9/16	1/2	0.031	0.562	+/- 0.006	+/- 0.003	70.3 (4.8)	352 (24.3)	4-1/2
5/8	9/16	0.031	0.625	+/- 0.006	+/- 0.003	63 (4.3)	315 (21.7)	5-1/2
5/8	1/2	0.062	0.625	+/- 0.006	+/- 0.003	132 (9.1)	659 (45.4)	3
11/16	5/8	0.031	0.688	+/- 0.006	+/- 0.003	57 (3.9)	285 (19.7)	4
3/4	11/16	0.031	0.750	+/- 0.006	+/- 0.003	52 (3.6)	260 (17.9)	8
3/4	5/8	0.062	0.750	+/- 0.006	+/- 0.003	108 (7.4)	541 (37.3)	6
7/8	3/4	0.062	0.875	+/- 0.007	+/- 0.003	92 (6.3)	459 (31.6)	12
1	7/8	0.062	1.000	+/- 0.010	+/- 0.003	80 (5.5)	398 (27.4)	16
1-1/4	1-1/8	0.062	1.250	+/- 0.015	+/- 0.004	63 (4.3)	315 (21.7)	
1-3/8	1-1/4	0.040	1.375	+/- 0.015	+/- 0.004	57 (3.9)	285 (19.7)	

## Tapered Fluoropolymer NMR Tube Caps

These precision-engineered fluoropolymer caps feature an advanced tapered closure design that interfaces seamlessly with fire-polished tube ends. The progressive taper creates superior sealing performance, ensuring sample integrity and preventing sample loss even under thermal cycling conditions.

### Key Performance Features

- Precision-tapered geometry for optimal seal engagement
- Compatible with fire-polished tube end specifications
- Maintains seal integrity during temperature gradients
- Superior sample containment for critical applications
- Chemically inert fluoropolymer construction

Item No.	Description
TC-3-PTFE	3 mm White Tube Cap
TC-4-PTFE	4 mm Blue Tube Cap
TC-5-PTFE	5 mm White Tube Cap
TC-10-PTFE	10 mm White Tube Cap



## Permanent Ink Ultra Fine Point Markers

Use this high quality, permanent ink, ultra fine point marker to clearly mark & organize all of your NMR Tube samples.

Item No.
MARKER-RED, MARKER-BLUE, or MARKER-BLACK



## Long Tip Pasteur Pipettes Designed for NMR Tubes

These precision-drawn borosilicate glass pipettes are specifically engineered for NMR sample handling, featuring extended tips that reach the bottom of 203 mm (8") NMR tubes while maintaining optimal sample transfer control.

### Glass Specifications

Manufactured from USP Type I and ASTM E438 Type I Class B borosilicate glass, providing superior chemical resistance and minimal extractable contamination. The low thermal expansion coefficient ensures excellent thermal shock resistance for temperature-sensitive applications.

### Compatibility

- 5 mm NMR tubes (all lengths): including medium wall tubes up to 0.8 mm thickness
- 3 mm NMR tubes: 178 mm (7") length with walls up to 0.38 mm (Select Series and Sample Vault Series)
- Universal compatibility with standard rubber bulbs and pipetting devices

### Technical Specifications

- Total volume capacity: 2.5 ml (providing ample headspace for typical 1 ml NMR sample volumes)
- Body diameter: 7 mm O.D. for standard laboratory pipetting device compatibility
- Tip design: uniformly drawn for precise sample access and transfer

### Key Benefits

The extended tip length and precision bore design enable accurate sample placement and retrieval from deep NMR tubes while the high-purity glass construction prevents sample contamination in sensitive analytical applications.

Item No.	Description	Packed In Lots of
NP204	long tip, 8" (203 mm) point	100
NPB01	1 ml Rubber Pipette Bulb	10

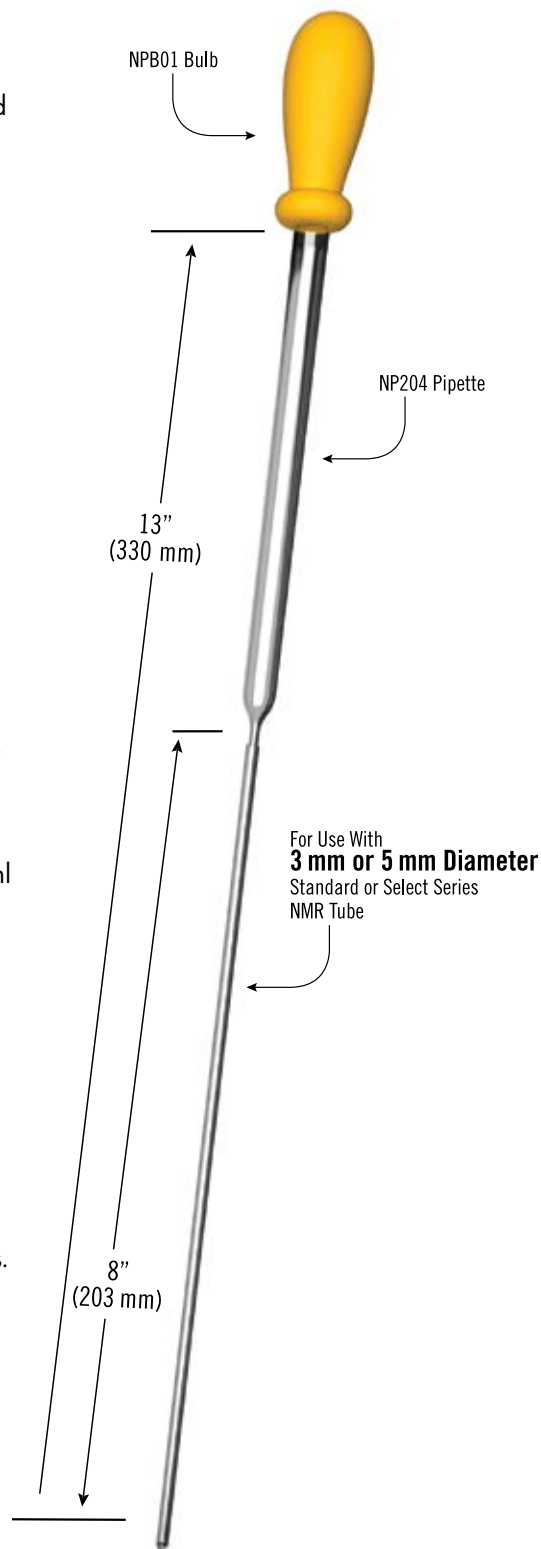

# ACCESSORIES

## Optimizer Inserts™ for 5 mm Spinner Turbines

These precision-engineered adapters enable multiple tube diameters within standard 5 mm spinner turbines, eliminating the need for additional turbine purchases while optimizing sample volume for enhanced sensitivity and resolution. Manufactured from proprietary acetal homopolymer resin for dimensional stability and chemical resistance.

### Compatible Tube Diameters

1.5 mm, 1.7 mm, 2.0 mm, 2.5 mm, 3.0 mm, 4.0 mm, & 4.25 mm O.D. NMR tubes

### Spectrometer Compatibility

Available for Agilent/Varian, Bruker, and JEOL spinner turbine systems (turbines sold separately)

### Primary Applications

- Method development for sensitivity and resolution optimization
- Biological sample analysis with challenging matrices
- High salt concentration and buffered solution studies
- Sample volume optimization across seven tube sizes
- Cost-effective alternative to multiple turbine systems

### Operating Specifications

- **Temperature range:** 0°C to 65°C (near room temperature applications)
- **Material:** Proprietary acetal homopolymer resin formulation
- **Patent protection:** U.S. Patent #7,728,593

### Key Benefits

The Optimizer Insert system provides analytical flexibility by enabling sample volume optimization across multiple tube diameters using existing 5 mm infrastructure, reducing equipment costs while maintaining precision performance for demanding NMR applications.

Item No.	Tube Size (mm)	Spinner Type
5X1.5INS-B	1.50	Bruker
5X1.5INS-J	1.50	JEOL
5X1.5INS-V	1.50	Agilent/Varian
5X1.7INS-B	1.70	Bruker
5X1.7INS-J	1.70	JEOL
5X1.7INS-V	1.70	Agilent/Varian
5X2INS-B	2.00	Bruker
5X2INS-J	2.00	JEOL
5X2INS-V	2.00	Agilent/Varian
5X2.5INS-B	2.50	Bruker
5X2.5INS-J	2.50	JEOL
5X2.5INS-V	2.50	Agilent/Varian
5X3INS-B	3.00	Bruker
5X3INS-J	3.00	JEOL
5X3INS-V	3.00	Agilent/Varian
5X4INS-B	4.00	Bruker
5X4INS-J	4.00	JEOL
5X4INS-V	4.00	Agilent/Varian
5X4.25INS-B	4.25	Bruker
5X4.25INS-J	4.25	JEOL
5X4.25INS-V	4.25	Agilent/Varian
10X1.5INS-AV	1.50	Agilent/Varian
10X1.7INS-AV	1.70	Agilent/Varian

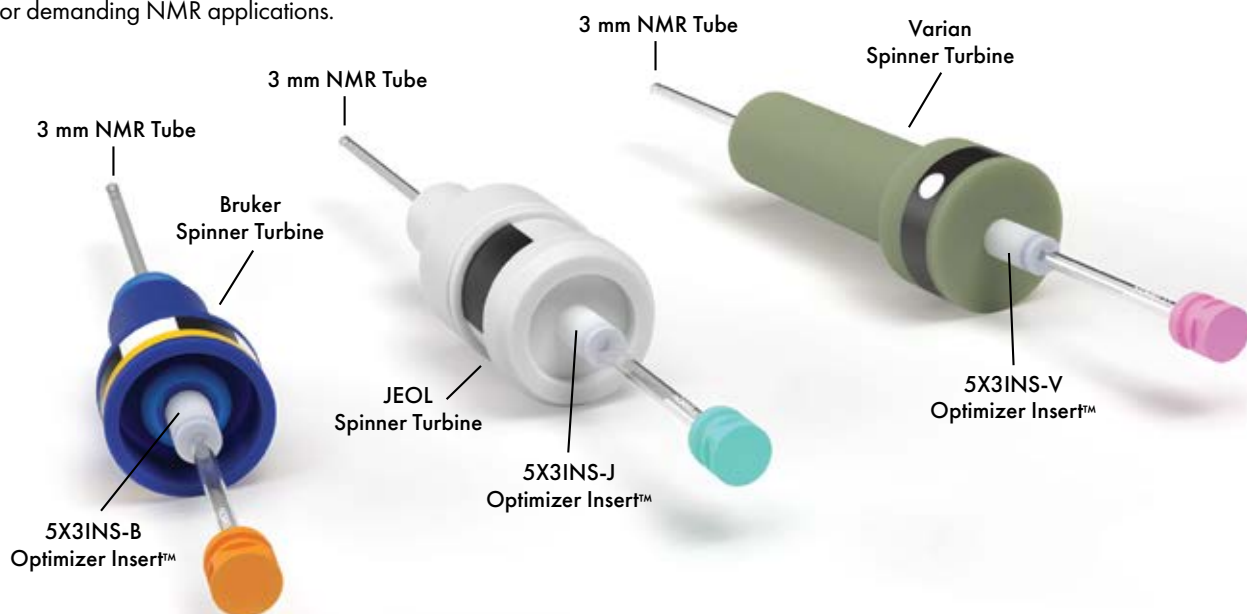

## Optimizer Inserts™ for 5 mm Spinner Turbines

5 mm O.D. Insert for use with a Bruker Spinner Turbine



5 mm O.D. Insert for use with a JEOL Spinner Turbine



5 mm O.D. Insert for use with a Varian Spinner Turbine



Fluoroelastomer O-Ring provides a frictional grip to retain the NMR sample tube in place



5 mm O.D. Inserts for Bruker, JEOL & Varian Spinner Turbines also available for 1.5 mm, 1.7 mm, 2 mm, 2.5 mm, 3 mm, 4 mm & 4.25 mm NMR Sample Tubes.

## Optimizer Inserts™ for 5 mm Spinner Turbines - PEEK Edition

Engineered with high-performance PEEK (polyetheretherketone), these advanced adapters deliver all the versatility of our standard Optimizer Inserts™ with enhanced material properties for the most demanding NMR applications. The superior dimensional stability, exceptional chemical resistance, and enhanced durability of PEEK enable reliable performance across extended temperature ranges and harsh chemical environments.

### Compatible Tube Diameters

1.5 mm, 1.7 mm, 2.0 mm, 2.5 mm, 3.0 mm, 4.0 mm, & 4.25 mm O.D. NMR tubes

### Spectrometer Compatibility

Available for Agilent/Varian, Bruker, and JEOL spinner turbine systems

### Primary Applications

- Method development for sensitivity and resolution optimization
- Biological sample analysis with challenging matrices
- High salt concentration and buffered solution studies
- Variable temperature NMR studies with demanding thermal requirements
- Harsh chemical environments requiring superior resistance
- Sample volume optimization across seven tube sizes
- Premium alternative to multiple turbine systems

### Operating Specifications

- **Extended temperature range:** -40°C to +250°C (variable temperature capability)
- **Material:** High-performance PEEK thermoplastic
- Enhanced chemical resistance to aggressive solvents and reagents
- **Patent protection:** U.S. Patent #7,728,593

### Key Benefits

The PEEK Optimizer Insert system delivers premium analytical flexibility with superior material properties for the most demanding NMR applications. Enhanced temperature capability and exceptional chemical resistance enable sample volume optimization across challenging experimental conditions while maintaining precision performance and extending service life.

Item No.	Tube Size (mm)	Spinner Type
5X1.5INS-PE-B	1.50	Bruker
5X1.5INS-PE-J	1.50	JEOL
5X1.5INS-PE-V	1.50	Agilent/Varian
5X1.7INS-PE-B	1.70	Bruker
5X1.7INS-PE-J	1.70	JEOL
5X1.7INS-PE-V	1.70	Agilent/Varian
5X2INS-PE-B	2.00	Bruker
5X2INS-PE-J	2.00	JEOL
5X2INS-PE-V	2.00	Agilent/Varian
5X2.5INS-PE-B	2.50	Bruker
5X2.5INS-PE-J	2.50	JEOL
5X2.5INS-PE-V	2.50	Agilent/Varian
5X3INS-PE-B	3.00	Bruker
5X3INS-PE-J	3.00	JEOL
5X3INS-PE-V	3.00	Agilent/Varian
5X4INS-PE-B	4.00	Bruker
5X4INS-PE-J	4.00	JEOL
5X4INS-PE-V	4.00	Agilent/Varian
5X4.25INS-PE-B	4.25	Bruker
5X4.25INS-PE-J	4.25	JEOL
5X4.25INS-PE-V	4.25	Agilent/Varian
10X1.5INS-PE-AV	1.50	Agilent/Varian
10X1.7INS-PE-AV	1.70	Agilent/Varian

## PEEK Optimizer Inserts™ for 5mm Spinner Turbines

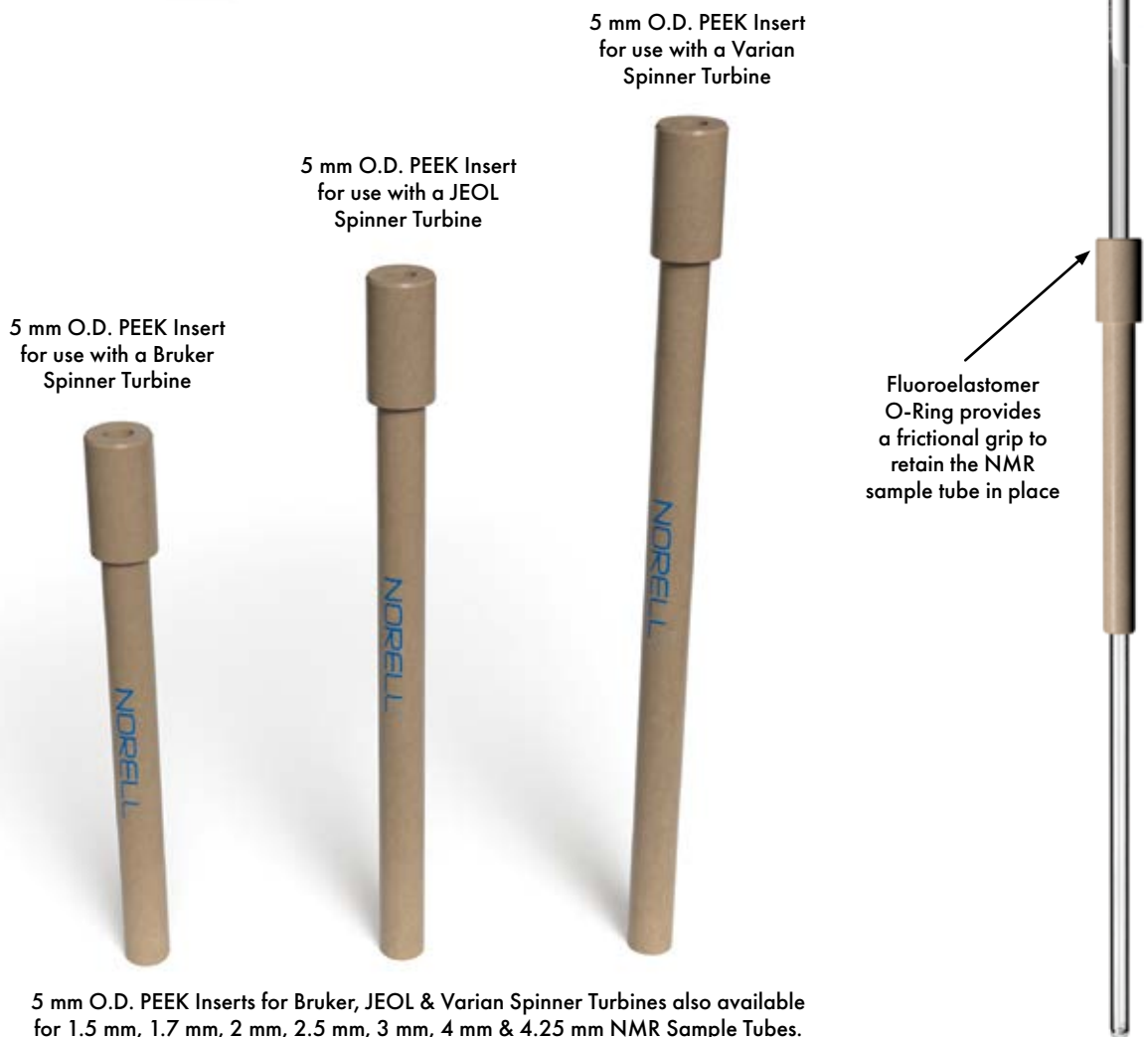
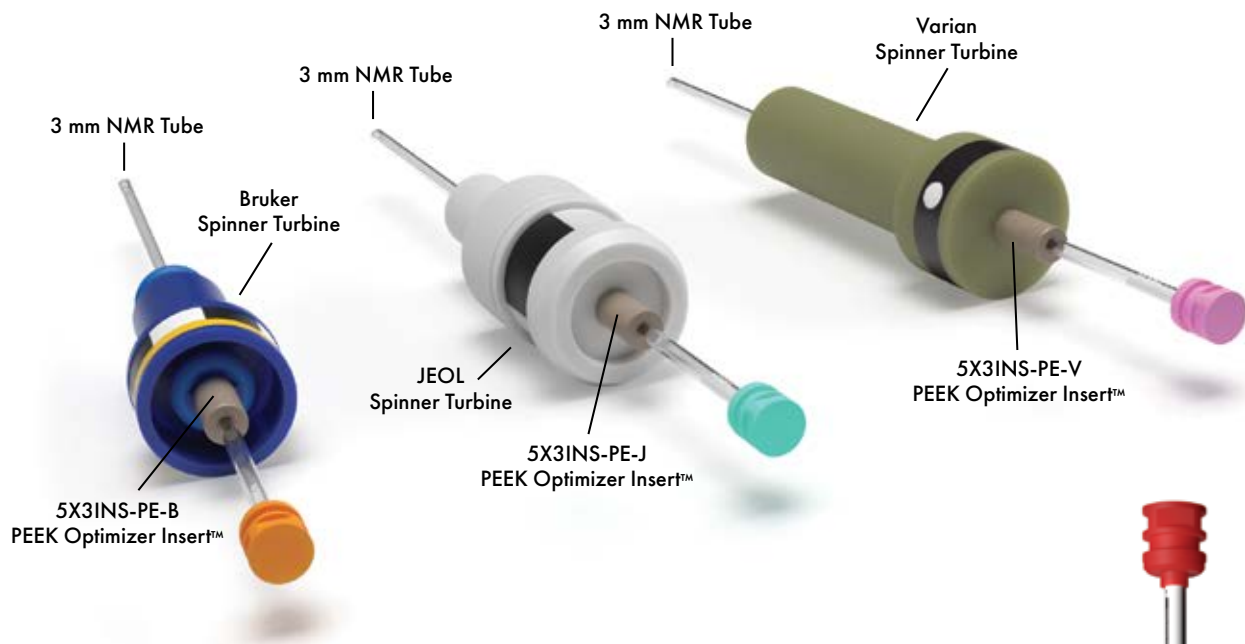

5 mm O.D. PEEK Inserts for Bruker, JEOL & Varian Spinner Turbines also available for 1.5 mm, 1.7 mm, 2 mm, 2.5 mm, 3 mm, 4 mm & 4.25 mm NMR Sample Tubes.

## High Performance Spinner Turbine Toroids

These precision toroids outperform standard OEM o-rings through advanced fluorosilicone elastomer construction developed for aerospace applications. The material provides extended temperature range with maintained flexibility, enhanced chemical and solvent resistance, and superior UV and ozone degradation resistance compared to standard elastomers.

Fluorosilicone construction addresses common failure modes while delivering extended service intervals, superior sealing performance, and consistent operation across temperature ranges. Ideal for spinner turbine maintenance programs requiring maximum reliability and reduced downtime, these aerospace-grade components provide cost-effective performance upgrades over standard replacement parts.

Item No.	Spinner Size (mm)	Spinner Type	Packed In Lots of
HPT5B-2PK	5	Bruker POM RT	2
HPT5B-10PK	5	Bruker POM RT	10
HPT5BC-2PK	5	Bruker Ceramic VT	2
HPT5BC-10PK	5	Bruker Ceramic VT	10
HPT5V-2PK	5	Varian	2
HPT5V-10PK	5	Varian	10
HPT3B-2PK	3	Bruker POM RT	2
HPT3B-10PK	3	Bruker POM RT	10
HPT3V-2PK	3	Varian	2
HPT3V-10PK	3	Varian	10
HPT10B-2PK	10	Bruker POM RT	2
HPT10B-10PK	10	Bruker POM RT	10

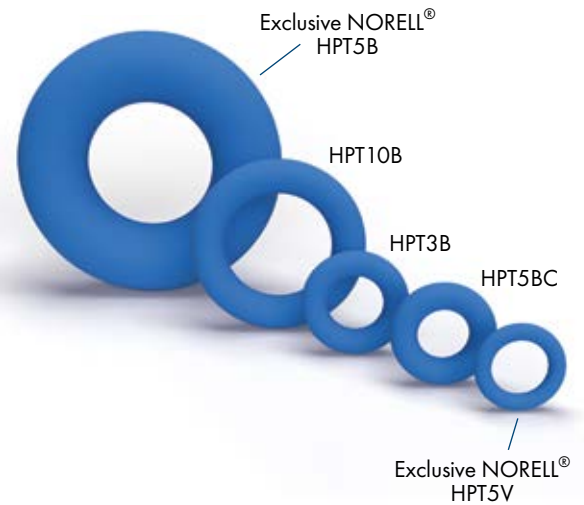

## SB-5 Spinner Brush

This specialized cleaning brush features a polyurethane foam tip mounted on a polypropylene handle, engineered specifically for 5 mm spinner turbine maintenance. The foam tip resists shredding and lint generation while providing excellent chemical and solvent resistance for use with common laboratory solvents.

The generous 6-inch overall length enables complete access to the inner bore of Varian-style spinner turbines, while the 1/4-inch diameter, nearly 1-inch long foam tip provides optimal contact and cleaning action within the precise bore dimensions of 5 mm spinner turbines. Both components deliver excellent chemical resistance for reliable cleaning performance across diverse solvent systems.



Item No.	Description	Packed In Lots of
SB-5	5 mm Spinner Brush	1

## Fluoropolymer NMR Tube Liners

Designed for NMR studies involving chemically aggressive compounds such as hydrofluoric acid, ammonium bifluoride, and concentrated hydroxide solutions. These fluoropolymer tube liners feature thin-wall construction that minimizes filling-factor losses while providing excellent chemical resistance. Each liner is supplied with a PTFE plug closure.

Item No.	Tube Liner Size	Fits Liner Tube Kit Size	Volume at 50mm
TL-3-7	2 mm	3 mm	approx. 0.23ml
TL-5-7	4 mm	5 mm	approx. 0.35 ml
TL-10-7	9 mm	10 mm	approx. 2.00 ml



## Fluoropolymer Liner Tube Kits for <sup>29</sup>Si and <sup>11</sup>B NMR

For silicon and boron NMR applications, we recommend using either the TL-3-TUBEKIT for 3 mm probes, TL-5-TUBEKIT for 5 mm probes or the TL-10-TUBEKIT for 10 mm probes. Each kit is designed to be compatible with Varian, Bruker, or JEOL spinners, which serve as holding devices for the fluoropolymer liner. Since the probe detects only the fluoropolymer environment, these kits enable acquisition of high-quality <sup>29</sup>Si and <sup>11</sup>B spectra without interference from glass or other materials.

Item No.	Contents
TL-3-TUBEKIT	two o-rings & one 3 mm open-end tube
TL-5-TUBEKIT	two o-rings & one 5 mm open-end tube
TL-10-TUBEKIT	two o-rings & one 10 mm open-end tube



## Full View of Complete Assembly of a 5 mm Spinner Turbine

Fluoropolymer Liner Tube Kit, Item Number TL-5-TUBEKIT for use with a 5 mm probe and spinner turbine.

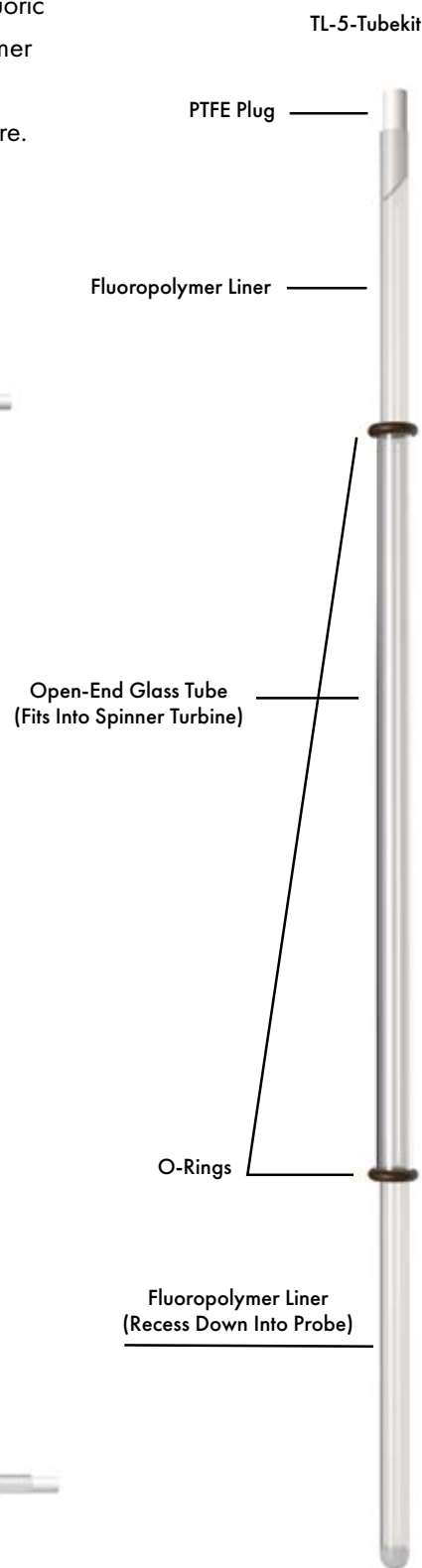
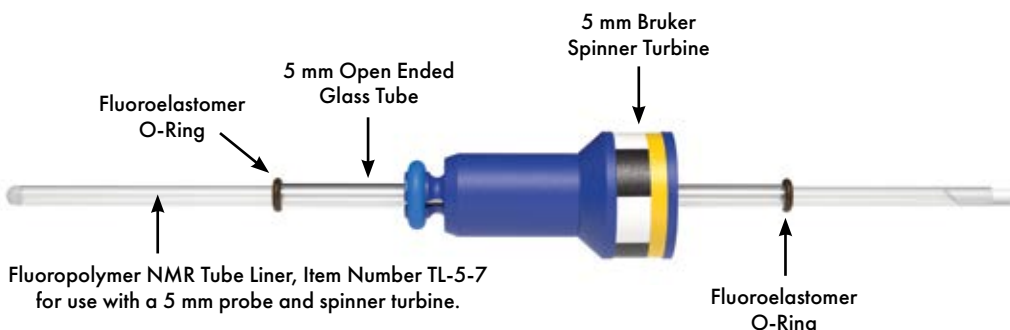

## NORELL® 3 mm & 5 mm NMR Tube Brushes

Designed for manual cleaning of 3 mm OD × 7" long thin-wall NMR tubes. This handheld NMR tube brush effectively removes stubborn contaminants from the inner surface of 3 mm thin-wall NMR tubes up to 7" in length. The 1/8" brush diameter fits securely within the NMR tube, while the soft nylon bristles clean thoroughly without scratching or abrading the interior glass surface. The brush stem features rugged construction with galvanized steel wire wound in a single spiral for secure bristle retention. At 8" overall length, the brush includes a wire loop handle for comfortable gripping during use.



Item No.	Description	Packed In Lots of
NTB-3X8	NMR Tube Brush for 3 mm Tubes - Nylon Bristle Brush with Loop Handle - Overall Length 8"	1
NTB-3X4	NMR Tube Brush for 3 mm Tubes - Nylon Bristle Brush with Loop Handle - Overall Length 4"	1
NTB-5X12	NMR Tube Brush for 5 mm Tubes - Nylon Bristle Brush with Loop Handle - Overall Length 12"	1
NTB-10x12	NMR Tube Brush for 10 mm Tubes - Nylon Bristle Brush with Loop Handle - Overall Length 12"	1

## NorLoc™ Tube Rack

The 5 mm NorLoc™ NMR sample tube rack from Norell® is crafted from laboratory-engineered, high-strength, high-modulus biopolymer. This versatile rack functions as both an attractive desktop display and a practical temporary storage solution for NMR samples.

Available in four standard colors, with an optional fifth "surprise" selection featuring random specialty finishes that may include metallic, multi-colored, or glow-in-the-dark materials.

Item No.	Description
NTR-5-B	NorLoc™ Tube Rack Norell® Blue
NTR-5-R	NorLoc™ Tube Rack Red
NTR-5-W	NorLoc™ Tube Rack White
NTR-5-BK	NorLoc™ Tube Rack Midnight
NTR-5-AS	NorLoc™ Tube Rack Surprise



## NMR Tube Cleaner, 5 Position

Featuring an all-glass and fluoropolymer design, the U505 cleans five NMR tubes of the same or various lengths and diameters simultaneously. The fluoropolymer adapter provides five positions with flexible 1/8" fluoropolymer tubing supplied in 9" lengths that can be trimmed to the desired height. The NMR tube is placed over the tubing and seated in the adapter, maintaining a small gap between the fluoropolymer tubing end and the tube's inner bottom surface.

**Operation:** With the stopcock closed, connect the reservoir to a low-vacuum source. Add cleaning solvent to the adapter, then air-dry to complete the cleaning process within seconds. The flexible tubing and adapter design minimizes tube breakage, while the stopcock enables easy solvent drainage. The hose connection features 10 mm diameter at the largest serration.

Item No.	Description
U505	for 5 mm - 10 mm NMR tubes

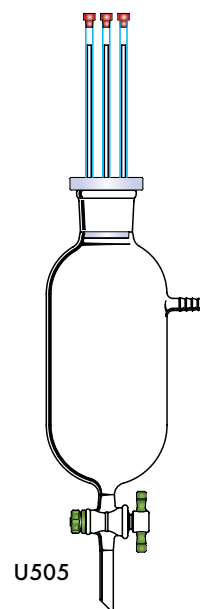

## Tube Washing Unit

The NMR Sample Tube Washing Unit is constructed from borosilicate glass, making it essential for laboratories routinely cleaning NMR sample tubes. This unit enables washing, rinsing, and drying of NMR tubes in a single, streamlined process.

Item No.	Description
U500	for 5 mm NMR tubes



## NorLoc™

PAT8054080

*The Next Generation of NorLoc™ NMR Tube Caps  
In A Rich Palette of Fresh, Vibrant Colors*

Advance to the next level of sample security, personal safety, and time savings. Combine Norell NorLoc™ II Security Caps™ with Norell Secure Series™ NMR tubes to experience the ultimate sample containment system.

Standard 5 mm and 3 mm NMR tube cap designs have remained unchanged for decades. Many users can attest to the significant flaws inherent in traditional NMR tube caps, especially when capping numerous sample tubes.

The NorLoc™ II Security Caps™ feature an internal patented design that addresses many flaws in traditional NMR tube caps while introducing substantial improvements not found in other NMR tube caps.

### **Key Design Features:**

The NorLoc™ II Security Cap™ applies more easily and quickly, increasing personal safety and saving valuable time. It incorporates an advanced dual-seal design, providing superior sealing and retention capabilities, especially when combined with Secure Series™ or other Norell NMR tubes featuring the Security Band™ that interlocks with the NorLoc™ II Security Cap™.

This interlocking capability creates superior cap retention, forming a “vaulted seal” that increases barrier performance with any NMR tube. The locking

interaction prevents NMR tube and cap separation, safeguarding precious samples during refrigerated storage, temperature cycling, or repeated cap removal and reapplication.

### **Patented Design Elements:**

The patented design includes an expanded entryway or guide section that helps align and position the cap on the NMR tube. Adjacent to this, a constriction forms a tight, effective seal against the tube wall, followed by a second constriction that creates a dual seal. The innermost region expands slightly in diameter, allowing the NMR tube to slip through easily, creating positive indication of proper placement and “lock” for a reliable “vaulted seal.”

The upper straight edge of the patented marking area on Secure Series™ or other Norell NMR tubes provides clear visual indication of the limit for complete closure with the NorLoc II Security Cap™.

### **Performance Advantages:**

When preparing dozens or hundreds of samples, tube capping consumes significant time. Traditional caps must be held at an angle, then stretched and twisted onto the tube—a tedious process that often results in tilted, misshapen caps promoting poor seals and splits. This process creates mechanical stress in glass NMR tubes, frequently leading to breakage, spilled samples, and potential injuries.

With the NorLoc™ II Security Cap™, the NMR tube enters the expanded guide section and becomes self-aligning, allowing the cap to be pushed straight onto the tube. This method leverages the compressive strength of glass while minimizing radial and torsional stresses that cause glass fracture from stretching and twisting traditional caps.

Proper, trouble-free closure is ensured by combining NorLoc™ II Security Caps™ with Secure Series™ or other Norell NMR tubes, creating a “vaulted seal” that resists separation even with challenging solvents such as chloroform-d. This provides precise, uniform cap positioning and seal integrity, safeguarding critical samples against losses from evaporation, contamination, or atmospheric degradation.



## The NORELL® NorLoc™ Generation II Security Cap™ Features:

- Internal patented Security Seal™ that provides superior hermetic sealing capability on all 5 mm and 3 mm NMR tubes.
- Significantly reduced force requirement for placement and removal, greatly enhancing safety during NMR tube capping operations.
- When combined with Secure Series™ or other Norell NMR tubes, the Security Band™ and Security Seal™ interlock to form a positive physical restraint system that prevents tube and cap separation, especially with challenging NMR solvents such as chloroform-d.

### STAGE I

#### For All Bruker/Agilent-Varian/JEOL Spinner Turbine-Based NMR Spectrometers

The dual-purpose proprietary security band enables safe, reliable, and secure placement of the NorLoc II cap.

Simply align the specially enlarged cap opening with the NMR tube and lightly push the cap to the natural stop created by the security band. This placement and single-stage seal represents a novel advancement in laboratory safety with enhanced performance and ergonomic design.



### STAGE II

#### For Bruker Sample Jet Systems

For Bruker Sample Jet applications, apply additional pressure on the NorLoc II cap to engage the cap's locking mechanism with the tube's security band. Proper

engagement is confirmed when the bottom of the cap contacts the exterior tube marking area. The dual-stage mechanism provides superior hermetic sealing, while the interlock forms a positive physical restraint system that prevents tube and cap separation, especially with challenging NMR solvents such as chloroform-d.



#### NorLoc II Cap Compatibility

NorLoc II Caps are designed to work with all standard 5 mm and 3 mm NMR sample tubes. While they provide enhanced security features when paired with NORELL® Secure Series™ Sample Tubes through the interlocking Security Band™ system, NorLoc II Caps deliver superior sealing performance on any NMR tube compared to traditional caps.

## NORLOC™ Generation II Series... Ingenuity, Precision, Proven Results

Patented Design with Superior  
Holding & Sealing Capabilities

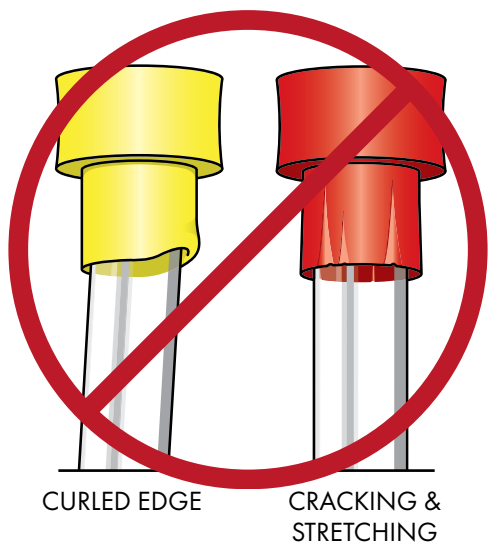
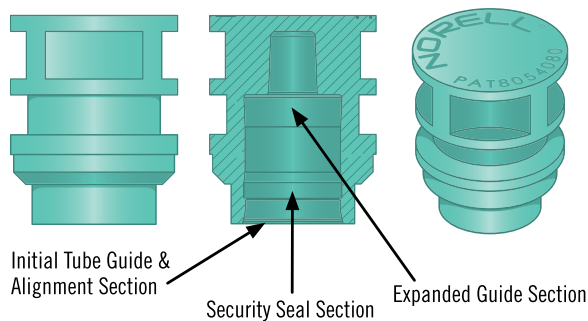

## NORLOC™ The New Standard for NMR Tube Caps

Item No.	Cap Color	Size	Packed in Lots of
NORLOC2-5-PA	Purple Acai	5 mm	100
NORLOC2-5-GW	Glacier White	5 mm	100
NORLOC2-5-BO	Black Onyx	5 mm	100
NORLOC2-5-MJ	Mint Julep	5 mm	100
NORLOC2-5-LY	Lemon Yellow	5 mm	100
NORLOC2-5-BH	Blue Harbor	5 mm	100
NORLOC2-5-SG	Sea Glass	5 mm	100
NORLOC2-5-RP	Red Poppy	5 mm	100
NORLOC2-5-OT	Orange Tangerine	5 mm	100
NORLOC2-5-PS	Pink Sorbet	5 mm	100
NORLOC2-5-GE	Green Envy	5 mm	100
NORLOC2-5-BR	Blue Royal	5 mm	100
<hr/>			
NORLOC2-3-PA	Purple Acai	3 mm	100
NORLOC2-3-GW	Glacier White	3 mm	100
NORLOC2-3-BO	Black Onyx	3 mm	100
NORLOC2-3-MJ	Mint Julep	3 mm	100
NORLOC2-3-LY	Lemon Yellow	3 mm	100
NORLOC2-3-BH	Blue Harbor	3 mm	100
NORLOC2-3-SG	Sea Glass	3 mm	100
NORLOC2-3-RP	Red Poppy	3 mm	100
NORLOC2-3-OT	Orange Tangerine	3 mm	100
NORLOC2-3-PS	Pink Sorbet	3 mm	100
NORLOC2-3-GE	Green Envy	3 mm	100
NORLOC2-3-BR	Blue Royal	3 mm	100

## 12 Vibrant Colors!



# ACCESSORIES



## Economy NMR Tube Caps

More Cap Colors for Better Solvent Labeling Capabilities

Item No	Description	Material	Color
TC-3-LPE-R	3 mm Tube Cap	Low Density Polyethylene	RED
TC-4-EVA-Y	4 mm Tube Cap	Ethylene-Vinyl Acetate	YELLOW
TC-4.25-EVA-Y	4.25 mm Tube Cap	Ethylene-Vinyl Acetate	YELLOW
TC-5-EVA-AS	5 mm Tube Cap	Ethylene-Vinyl Acetate	ASSORTED
TC-5-EVA-S	5 mm Tube Cap	Ethylene-Vinyl Acetate	SKY
TC-5-EVA-PK	5 mm Tube Cap	Ethylene-Vinyl Acetate	PINK
TC-5-EVA-A	5 mm Tube Cap	Ethylene-Vinyl Acetate	AQUA
TC-5-EVA-F	5 mm Tube Cap	Ethylene-Vinyl Acetate	FUCHSIA
TC-5-EVA-R	5 mm Tube Cap	Ethylene-Vinyl Acetate	RED
TC-5-EVA-G	5 mm Tube Cap	Ethylene-Vinyl Acetate	GREEN
TC-5-EVA-B	5 mm Tube Cap	Ethylene-Vinyl Acetate	BLUE
TC-5-EVA-Y	5 mm Tube Cap	Ethylene-Vinyl Acetate	YELLOW
TC-5-EVA-P	5 mm Tube Cap	Ethylene-Vinyl Acetate	PURPLE
TC-5-EVA-O	5 mm Tube Cap	Ethylene-Vinyl Acetate	ORANGE
TC-5-EVA-W	5 mm Tube Cap	Ethylene-Vinyl Acetate	WHITE
TC-5-EVA-BK	5 mm Tube Cap	Ethylene-Vinyl Acetate	BLACK
TC-10-LPE-R	10 mm Tube Cap	Low Density Polyethylene	RED
TC-10-LPE-B	10 mm Tube Cap	Low Density Polyethylene	BLUE
TC-10-LPE-G	10 mm Tube Cap	Low Density Polyethylene	GREEN
TC-10-LPE-Y	10 mm Tube Cap	Low Density Polyethylene	YELLOW

Economy NMR tube caps are now available in 12 different colors for enhanced solvent identification and laboratory organization. These colorful caps simplify experimental workflows and improve efficiency through better sample management.

## PTFE Syringe Tubing

These 12" lengths of PTFE syringe tubing provide an excellent means to access the bottom of small inner-diameter NMR tubes, enabling void-free filling with viscous solvents such as DMSO-d<sub>6</sub> or deuterium oxide.

This syringe tubing also permits easy retrieval of sample solutions from small-diameter NMR tubes or through the narrow orifice of valved NMR tubes.

The flexible, chemically inert PTFE tubing is supplied with a female Luer-lock hub on one end and a raw cut on the opposite end. The tubing can be easily cut and shortened to any desired length.

The Luer-lock hub fits syringes with male Luer taper connections, whether locking-type or slip-tip configurations, and is compatible with the syringes listed on page 69.

The Luer-lock hub is manufactured from Kel-F® (PCTFE or polychlorotrifluoroethylene), which provides excellent chemical resistance, mechanical strength, and deformation resistance.

Both PTFE and Kel-F® construction materials are virtually impervious to all common solvents, making the assembled syringe tubes washable and reusable for extended service life.

The table below presents several different gauge diameters of PTFE tubing, compatible with all Norell NMR tubes except 1 mm OD. Individual sizes may be purchased separately or as a complete kit containing one of each size. Upon request, additional gauge sizes from 30 to 7 are available, as well as custom lengths with female hubs on one end only or both ends.

### PTFE Syringe Tubing, 12 Inches Long, Kel-F® Female Luer-lock Hub on One End

Item No.	Recommended Minimum Size NMR Tube	Tubing Size (Gauge Number)	Nominal O.D.		Nominal I.D.	
			inch	mm	inch	mm
NDL-PTFE-28X12	1.5 mm O.D. thin wall tubes	28	0.033	0.84	0.015	0.38
NDL-PTFE-24X12	1.7 mm O.D. thin wall tubes	24	0.040	1.02	0.022	0.56
NDL-PTFE-22X12	2.0 mm O.D. thin wall tubes	22	0.046	1.17	0.028	0.71
NDL-PTFE-17X12	2.5 mm O.D. thin wall tubes, High Pressure Valved tubes	17	0.071	1.80	0.047	1.19
NDL-PTFE-16X12	3.0 mm O.D. thin wall tubes, 5.0 mm O.D. heavy wall tubes	16	0.077	1.96	0.053	1.35
NDL-PTFE-12X12	5.0 and 4.0 mm O.D. thin wall, 5.0 mm O.D. medium wall, all larger size tubes	12	0.109	2.77	0.085	2.16
NDL-PTFE-KITX12 (contains one each of the above items)	Suitable for all above sizes (except 1.0 mm O.D.)	One each of the above sizes	As per above	As per above	As per above	As per above

## Standard 3.5 mL & Semi-Micro 1.5 mL Cuvettes for UV-Visible Optical Spectroscopy

Two sizes are available: 3.5 mL (standard) and 1.5 mL (semi-micro). All cuvettes feature a 10 mm path length and are 45 mm in height. The semi-micro size has an internal width of 4 mm. Polyethylene cuvette caps are also available, designed for easy insertion and removal. These caps provide liquid-tight sealing suitable for sample mixing and storage. Sold in lots of 500. Contact us for custom sizes.

Item No.	Size	Packed In Lots of
NI9007	3.5 ml	500
NI9008	1.5 ml	500
NI9010	cap for cuvette	500

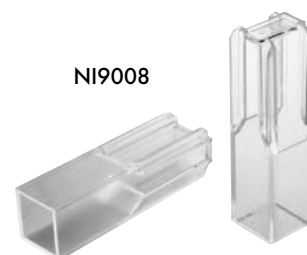

## Fluoropolymer Multi-Channel™ Distillation Column Packing

This unique, lightweight, efficient distillation column packing was developed in our R&D laboratories for the separation of H<sub>2</sub>O from D<sub>2</sub>O (heavy water) by distillation. The Ultra-High Purity Column Packing (MCD-8-UHP) is manufactured from perfluoroalkoxy (PFA), a material with low extractable impurities and high chemical resistance.

Being chemically inert with large contact surface area, this packing proved excellent for upgrading and separating deuterated solvents by distillation.

Testing has determined the HETP (Height Equivalent to a Theoretical Plate) to be approximately 14.2 cm using a standard test solution in carefully controlled experimental conditions. Performance specifications indicate that 100 g of 5 mm OD individual Multi-Channel™ units consists of 880 pieces, occupies 200 cm<sup>3</sup> in volume, and offers approximately 2720 cm<sup>2</sup> in total surface area.

Item No.	Weight	Approx. Volume	Size	Approx. Pieces Per Pack	Surface Area
MCD-5	250 g	500 cm <sup>3</sup>	5 mm	2200	6800 cm <sup>2</sup>
MCD-8	250 g	500 cm <sup>3</sup>	8 mm	876	6800 cm <sup>2</sup>
MCD-8-UHP	250 g	500 cm <sup>3</sup>	8 mm	876	6800 cm <sup>2</sup>

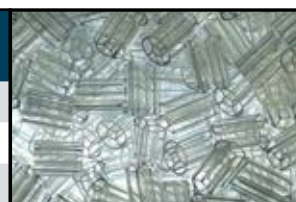

MCD-5

## Coaxial Inserts for NMR Sample Tubes

Precision inner cells for 5 mm and 10 mm thin-wall NMR tubes, designed for external lock and reference solvents. Available for Bruker and Varian spectrometers.

Item No.	Tube	Probe	Stem O.D. (mm)	Stem Length (mm)	Stem Capacity (µl)	Sample Capacity
NI5CCI-B	5 mm	Bruker	2	50	100	490 µL
NI5CCI-V	5 mm	Varian	2	60	120	590 µL
NI10CCI-B*	10 mm	Bruker	3	50	215	2.61 ml
NI10CCI-V*	10 mm	Varian	3	60	260	3.14 ml
NI5CCI-B-QTZ	5 mm	Bruker	3	50	175	285 µL
NI5CCI-V-QTZ	5 mm	Varian	3	60	210	340 µL

\* 10 mm insert for Bruker & Varian includes our 1008-UP 7" NMR tube

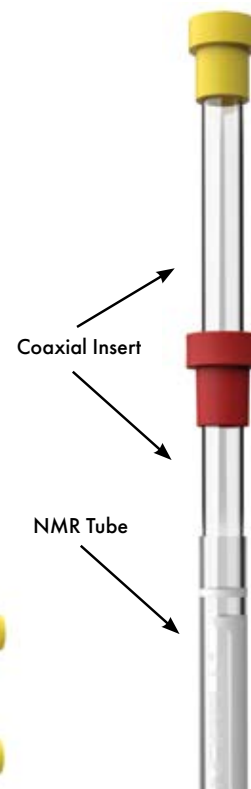
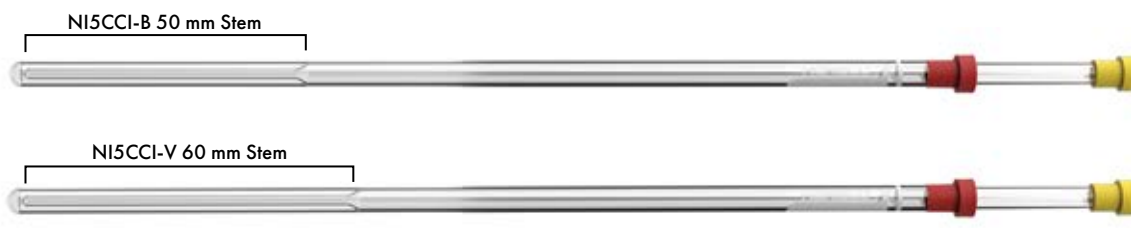

## Polypropylene Syringes

These syringes are latex-free and contain no rubber, silicone oil, or styrene. Manufactured exclusively from laboratory-grade polypropylene and polyethylene, each syringe incorporates a positive safety stop to prevent accidental spills. Packed in lots of 100.

Item No.	Description	Packed In Lots of
SR100	1 ml with 0.01 ml graduations	100
SR300	3 ml with 0.1 ml graduations	100
SR500	5 ml with 0.5 ml graduations	100
SR1000	10 ml with 0.5 ml graduations	100
NDL22	hypodermic needle for use with disposable syringes (stainless steel, translucent hub 22 guage x 1")	100

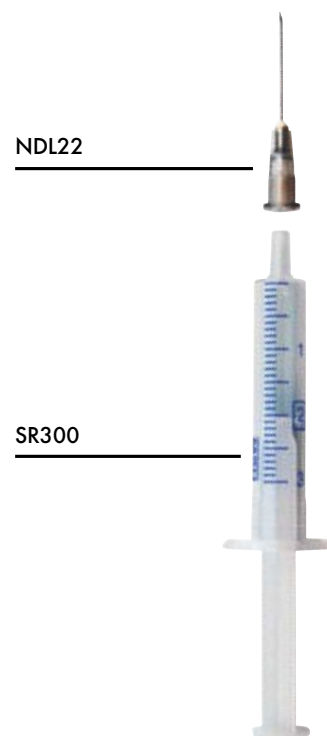

# ACCESSORIES

## 5 mm & 10 mm NMR Tube Septa

These precision-molded natural rubber septa for 5 mm and 10 mm NMR sample tubes seal against both the inner and outer surfaces of standard thin-wall NMR tubes, providing ultimate protection for sensitive or reactive samples by isolating them from air, moisture, and other ambient contaminants.

This dual-seal septum also protects personnel against exposure to samples that may pose health or safety hazards while allowing easy access through the septum using a syringe to add, transfer, or retrieve samples from the NMR tube.

The septa are molded from one certified raw material formulation, ensuring consistency across all sizes and from lot to lot. This soft, resilient natural rubber compound applies easily to NMR tubes and ampules without breaking or cracking fragile thin-wall tubes.

The soft rubber material tolerates multiple penetrations without losing sealing capability, especially when successive penetrations are made at the same location using a sharp, non-coring needle.

Septa should be stored in a sealed plastic bag away from sunlight to inhibit "blooming," a process that produces a harmless whitish film or powder on the natural rubber surface. Surface bloom does not affect performance and can be removed by wiping or washing.

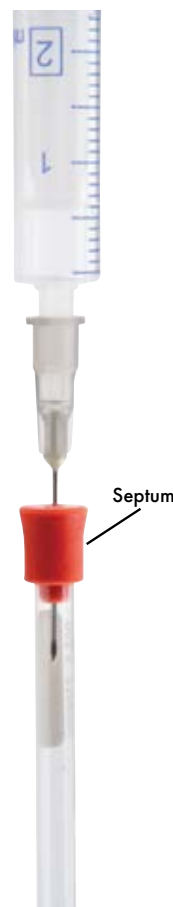

Item No.	Color	Packed In Lots of
SEPTA-5-W	White	100
SEPTA-5-R	Red	100
SEPTA-10-W	White	100
SEPTA-10-R	Red	100



## Silicone Rubber Stoppers for NMR Sample Tubes

These stoppers provide a solution for challenging situations when standard tube caps cannot be used, such as when space is a limiting factor. This problem occurs most often in solid-state NMR work when unique, compact, or experimental probe designs are encountered. The stoppers seal within the inner surface of the sample tube and therefore do not extend beyond the outer periphery of the sample tube as standard tube caps do.

Manufactured from soft, resilient silicone rubber, these stoppers form highly effective seals without applying excessive force to the glass sample tube, thereby minimizing tube breakage. The stoppers can be easily trimmed to length with a knife blade or scissors if desired. Silicone rubber construction provides a high degree of chemical inertness, solvent resistance, and high-temperature capability (up to 200°C).



Item No.	Description	Color	Packed in Lots of
TS-1.5-3-SR	Will fit our thin wall tubes having an O.D. of 1.5 mm to 3 mm. (1.2 mm to 2.4 mm I.D.)	clear translucent	50
TS-2.5-3-SR	Will fit our thin wall tubes having an O.D. of 2.5 mm to 3 mm. (2.1 mm to 2.4 mm I.D.)	light green	50
TS-4-SR	Will fit our thin wall tubes having an O.D. of 4 mm. (3.2 mm I.D.)	pink	50
TS-4-5-SR	Will fit our thin wall tubes having an O.D. of 4 mm to 5 mm. (3.2 mm to 4.2 mm I.D.)	black	50
TS-10-SR	Will fit our thin wall 10 mm O.D. tube. (8 mm to 11.5 mm I.D.)	clear translucent	10



## 5mm Biopolymer NMR Sample Tube Carrier from Norell®

The new biopolymer tube carrier from Norell® is manufactured from laboratory-engineered, high-strength, high-modulus biopolymer. This durable container protects both personnel and glass NMR tubes during temporary storage and transport, shielding against breakage and sample loss that might otherwise result from accidental drops, rolling off laboratory benches, or similar mishaps.

Item No.	Color	Packed in Lots Of
Norell Tube Carrier - BLACK	Black	1
Norell Tube Carrier - BLUE	Blue	1
Norell Tube Carrier - RED	Red	1
Norell Tube Carrier - WHITE	White	1
Norell Tube Carrier - BLACK x 3	Black	3
Norell Tube Carrier - BLUE x 3	Blue	3
Norell Tube Carrier - RED x 3	Red	3
Norell Tube Carrier - WHITE x 3	White	3

The carrier holds one 5 mm diameter × 7" long NMR tube with ample space for caps, including standard NMR tube caps, NorLoc™ caps, and fluoropolymer NMR tube caps. The twist-on cap fits securely and resists dislodging when struck or dropped, providing ultimate protection for precious or hazardous samples.

# TUBE SAFE

The **Tube Safe Valved NMR Tube Carrier** was originally developed for our own valved NMR tube shipping requirements. We have been shipping our valved NMR tubes in this design since 2022. After receiving client requests for the Tube Safe for their internal storage, transport, and shipping needs, we decided to offer it as a standalone product.

Designed for personal safe transport and as an additional safety layer when shipping alongside traditional packaging systems, the Tube Safe helps ensure the protection of valved NMR tube glass during transport.

The Tube Safe is manufactured from laboratory-engineered, high-strength, high-modulus biopolymer.

*NOTE: The NMR Tube Carrier is designed for personal, safe transport of samples within and between laboratories, to adjacent buildings, etc., but should not be considered suitable for use as a sole packaging system for shipping NMR tubes containing U.S. DOT or UN listed hazardous materials in commerce. It can be used as an additional intermediate packaging element providing added protection for sealed (not simply capped) NMR samples when supplemental packaging materials are used in accordance with the appropriate governing authority. Within the USA, please consult the United States Code of Federal Regulations, Title 49 Transportation, Subtitle B, to ensure full and complete compliance.*



## NMR Spinner Turbine Maintenance: O-Ring Replacement and Cleaning Procedures

Virtually all NMR spinner turbines rely on O-rings to hold NMR sample tubes securely in place. Depending on the design, most spinner turbines employ one or two O-rings for this purpose. The O-rings, manufactured from elastomer or rubber materials, allow the spinner turbine to hold sample tubes reliably even when small size differences occur between the spinner turbine and sample tube. These size variations arise when the spinner turbine/sample tube combination is exposed to temperatures above or below ambient conditions. Smaller deviations from the ideal match can also result from manufacturing process variations in both spinner turbines and sample tubes.

### O-Ring Deterioration and Replacement

O-rings can weaken or stretch and become less resilient with age and use. Because the inside diameter of the spinner turbine must necessarily be larger than the sample tube diameter, weakened or worn O-rings can allow the sample tube to slip through the spinner turbine and should therefore be replaced.

The two most commonly used O-ring materials for spinner turbines are silicone rubber (usually red or orange) and fluoroelastomer (usually black, sometimes brown). These materials possess excellent chemical and temperature resistance but lack optimal mechanical qualities such as abrasion, tear, and fatigue resistance. When sample tubes begin slipping into the spinner turbine more easily than usual, O-ring replacement is advisable.

### Factors Affecting O-Ring Life Expectancy

Many factors influence O-ring life expectancy, including frequency of use, environmental conditions (heat, humidity, corrosive atmospheres), and exposure to common NMR solvents. Storing spinner turbines with sample tubes inserted for extended periods can cause premature O-ring weakening. Therefore, implementing a preventive maintenance program for spinner turbines is recommended. As a general rule, O-rings should be replaced annually, though individual experience may dictate shorter or longer intervals.

### Cleaning Procedures

During O-ring replacement, the inside bore of spinner turbines should be thoroughly cleaned to remove surface films or contamination from hand contact, spilled samples, etc., especially at points where O-rings compress the spinner turbine into contact with the sample tube.

Tacky or adhesive-like contaminants at these contact points can cause "stick-slip" conditions, where sample tubes resist insertion into the spinner turbine. Applying excessive force to overcome this resistance can cause sudden sample tube slippage, resulting in broken tubes and injuries.

Conversely, contaminants with lubricating qualities at spinner contact points can cause sample tubes to shift position or slide downward, especially during handling or magnet transfer.

Cleaning should be performed at least as often as O-ring replacement, but monthly procedures are recommended.

# MAINTENANCE PROCEDURE FOR NMR SPINNER TURBINES

## O-Ring Replacement Procedures

Replacing O-rings on most spinner turbines is straightforward. For some designs, worn O-rings are simply pried or rolled off from the spinner turbine end. The replacement O-ring of correct size is then pushed or rolled onto the spinner turbine until it snaps into the grooved recess (if present).

Other spinner turbine designs position O-rings inside the bore near the end, where they contact and grip the sample tube surface. These O-rings are easily replaced using small pointed tools such as jeweler's screwdrivers, toothpicks, or precision tweezers to pry or pull worn O-rings from recessed grooves.

Replacement O-rings of correct size can be inserted by folding or compressing the O-ring until part of it enters the groove, then pushing in the remainder portion by portion using small, round, blunt tools with no sharp edges, such as plastic, glass, or metal rods.

## Cleaning Procedures

Cleaning procedures for all spinner turbines are simple and straightforward. It is particularly important to clean the inside bore near the O-rings at points where the spinner turbine contacts and grips the sample tube outer surface, though all surfaces, inside and out, should be cleaned.

**SAFETY NOTICE: THE FOLLOWING PROCEDURE SHOULD BE PERFORMED IN A LABORATORY FUME HOOD WHILE WEARING APPROPRIATE PERSONAL PROTECTION EQUIPMENT INCLUDING SOLVENT-RESISTANT GLOVES AND ADEQUATE EYE PROTECTION, SUCH AS LABORATORY SAFETY GOGGLES.**

The inside bore can be cleaned using swabs mounted on handles long enough to reach through the spinner turbine interior. The swab should be moistened with isopropanol, allowing all inside surfaces to be easily reached and wiped clean.

Isopropanol is an excellent solvent for removing most contaminants, is safe for spinner turbine materials, and is relatively non-toxic. Methanol can also be used as a cleaning solvent with excellent solvent properties and spinner turbine safety, but has higher toxicity than isopropanol.

Lint-free or fiber-free swabs are recommended, such as polyurethane foam, polyester fiber, or microfiber mounted on polypropylene or other plastic handles. These swabs will not leave fibers or lint inside spinner turbines but must be used only with isopropanol or methanol, as other solvents can soften or dissolve swab materials and leave residues.

Cotton swabs mounted on wooden handles can be used but may release cotton or wood fibers that could lodge inside spinner turbines. However, cotton and wood are impervious to almost all common laboratory solvents.

### **Bruker Typical Turbine**

Replaceable O-Rings  
(Replace With Exclusive  
Norell® HPT5B)

Important Contact Points  
Requiring Regular Cleaning

Exclusive NORELL®  
5X3INS-B Optimizer Insert™

### **Varian Typical Turbine**

Replaceable Internal O-Ring  
(Replace With Exclusive  
Norell® HPT5V)

Important Contact Point  
Requiring Regular Cleaning

Exclusive NORELL®  
5X3INS-V Optimizer Insert™

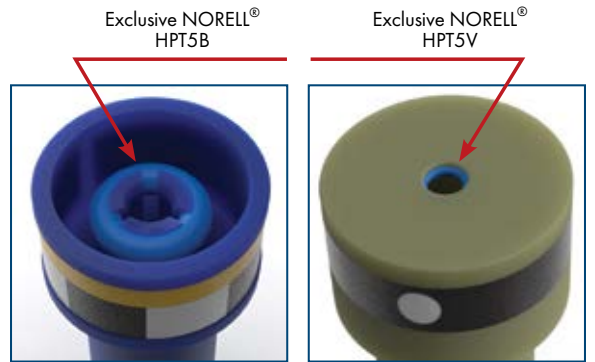

# INDEX

## 3 mm

3 mm Secure Series™	6-7
3 mm Select Series™	9
3 mm NMR Tubes for Ceramic Turbines	10-11

## 5 mm

5 mm NMR Tube Carriers	74
5 mm NMR Tube Septa	72
5 mm NMR Tubes for Ceramic Turbines	10-11
5 mm Secure Series™	4-7
5 mm Select Series™	8
5 mm Standard Series™	12-13

## 10 mm

10 mm NMR Tube Septa	72
10 mm Select Series™	8
10 mm Standard Series™	13

## A

Amberized NMR Tubes	42
---------------------	----

## B

Bruker MATCH™ NMR Tubes & Tube Caps	44
Bruker MATCH™ Tube Caps	45
Bruker Microbore Tubes	41
Brushes (Spinner)	60
Brushes (for 3 mm & 5 mm NMR Tubes)	62

## C

Caps (for NMR tubes)	18-23, 40, 45, 54, 68
Caps (NorLoc™)	64-67
Caps (Sample Vault™)	18-23
Ceramic Turbines, 3 mm & 5 mm NMR Tubes for	10-11

Closures for Open Port Caps	21
Coaxial Inserts for NMR Tubes	71
Column Packing	70
Constricted NMR Tubes	42
Cuvettes	70

## E

Extreme Series for High Pressure	36-39
----------------------------------	-------

## F

Fluoropolymer Column Packing	70
Fluoropolymer NMR Tube Liners	61
Fluoropolymer Liner Tube Kits	61
Fluoropolymer NMR Tube Caps	54
Fluoropolymer FEP Tubing	50-51
Fluoropolymer FEP Thin Wall Trans. Tubing	46
Fluoropolymer PFA Tubing	52-53
Fluoropolymer PTFE Tubing	47
Fluoropolymer PVDF Tubing	48-49

## H

Heavy Wall NMR Tubes	43
Heavy Wall Sample Vault™ NMR Tubes	19
High-Throughput NMR Tubes	41

## M

Markers (Permanent)	54
Medium Wall NMR Tubes	43
Medium Wall Sample Vault™ NMR Tubes	19
Microbore Tubes (Bruker)	41

## N

NorLoc™ Caps, 5 mm & 3 mm.....	64-67
NorLoc™ Cap Tube Rack .....	62

## O

Optimizer Inserts™ for 5 mm Turbines.....	56-57
---	-------

## P

Pasteur Pipettes.....	55
PEEK Optimizer Inserts™ .....	58-59
Permanent Markers.....	54
Polypropylene Syringes.....	71
PTFE Syringe Tubing.....	69

## Q

Quartz EPR Tubes.....	25
Quartz NMR Tubes.....	24-25

## S

Sample Vault™ NMR Tubes & Caps.....	18-23
Sample Vault™ NMR Sample Tube Rack.....	20
Screw-Cap NMR Tubes.....	40
Secure Series™.....	4-7
Select Series™ (3 mm, 5 mm, Tubes for Ceramic Turbines).....	8-11
Septa (for 5 mm & 10 mm NMR tubes).....	72
Silicone Rubber Stoppers.....	73
Spinner Brushes.....	60
Spinner Turbine Maintenance.....	75-77
Standard Series™ (5 mm, 10 mm).....	12-13
Suprasil® Quartz NMR & EPR Tubes.....	25
Syringes (Polypropylene).....	71
Syringe Tubing (PTFE).....	69

## T

Thin-Wall Transparent Fluoropolymer FEP Tubing.....	46
Toroids.....	60
Tube Caps.....	18-23, 40, 45, 54, 64-68
Tube Brushes (Norell 3 mm & 5 mm NMR).....	62
Tube Carriers (for 5 mm NMR Tubes).....	74
Tube Cleaner (5 Position).....	63
Tube Rack (Sample Vault™ by Norell®).....	20
Tube Rack (NorLoc™).....	60
Tube Safe Valved NMR Tube Carrier.....	74
Tube Washing Unit.....	63

## U

Ultra-Thin Wall NMR Tubes.....	14-16
--------------------------------	-------

## V

Valved NMR Tubes for Reduced Pressure.....	26-29
Valved NMR Tubes for Intermediate Pressure.....	30-34
Valved NMR Tubes for High Pressure.....	36-39



NORELL PRESENTS:

# THE SMARTEST CAT IN THE LAB

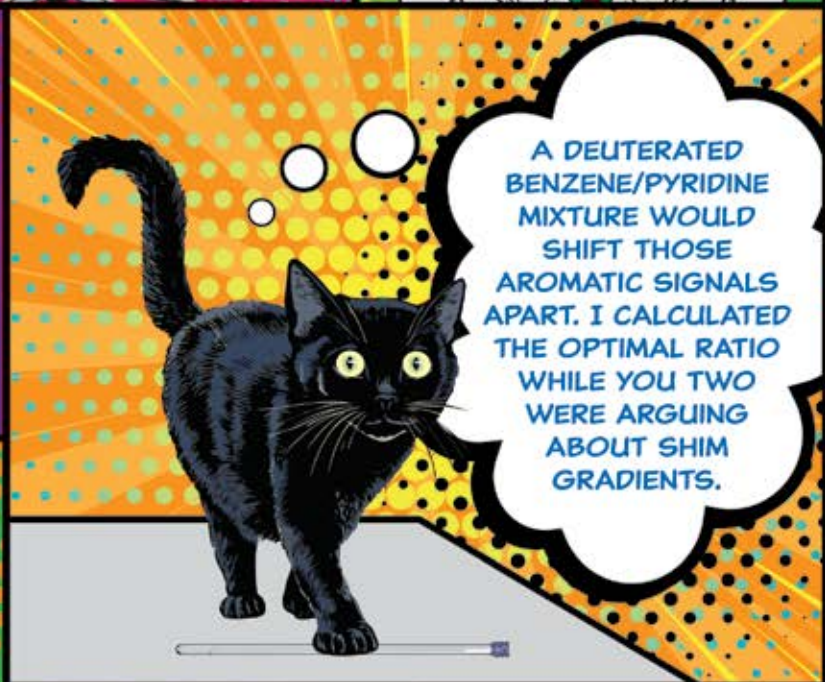

# EUREKA!



NORELL  
NMRTUBES.COM

NORELL®

**SINCE 1967**

For nearly six decades, Norell has stood alongside scientists like you, providing the precision tools that power breakthrough discoveries. From groundbreaking research to life-changing innovations, we're proud to be part of your journey. Let's continue pushing the boundaries of science together.

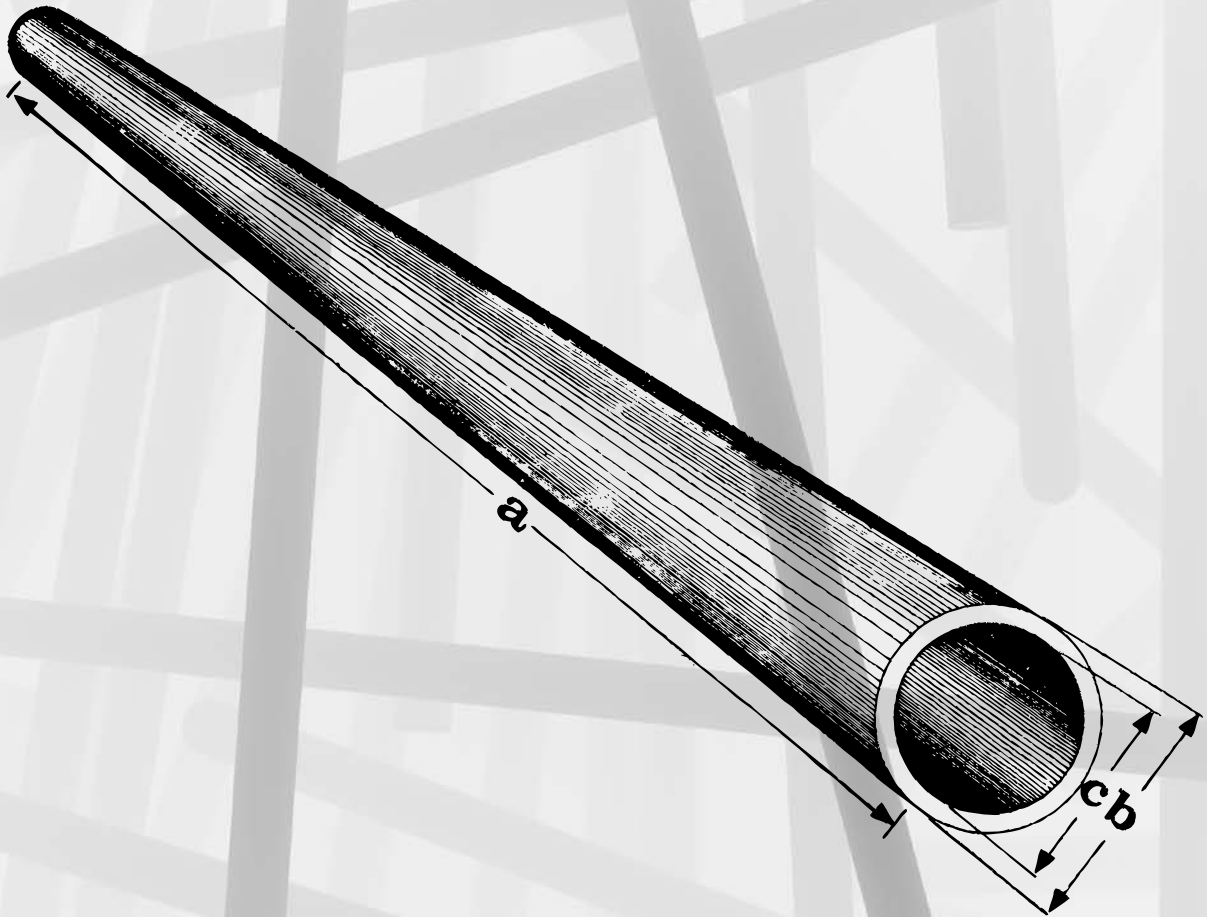

**IMAGINATION – INNOVATION – RESULTS...**  
**...IN SCIENCE AND IN BUSINESS**

Printed in United States of America • Since 1967  
Copyright ©2026 NORELL® • Version Number 06 • 11 • 2026

**NORELL**®  
SINCE 1967

Imagination • Innovation • Results  
In Science & in Business™

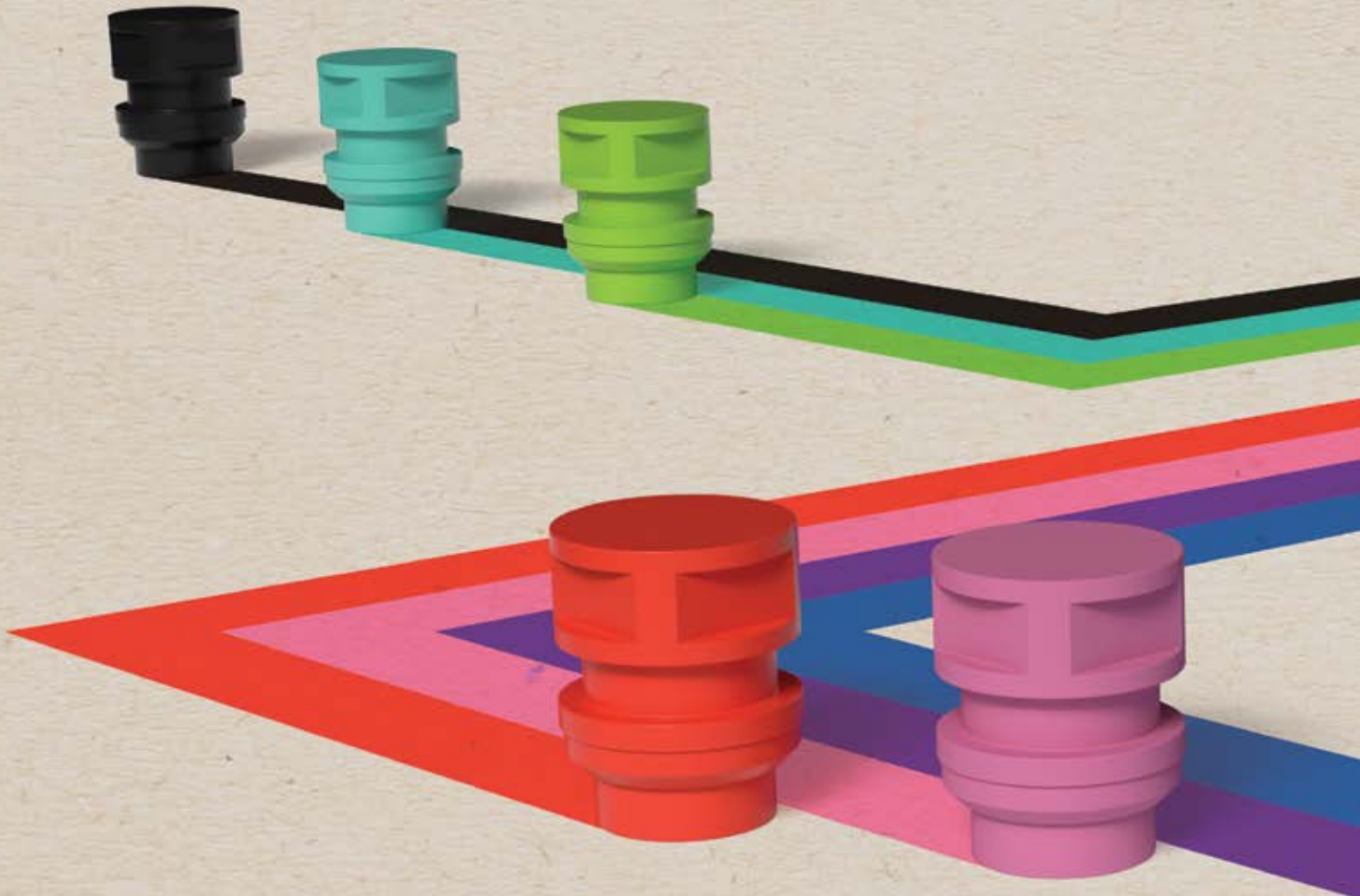

1.828.584.2600

[customerservice@nmrtubes.com](mailto:customerservice@nmrtubes.com)

1001 Innovation Drive • PO Box 1707 Morganton, NC 28680, USA

**NMRTUBES.COM**