

HVR120 - HVR700 HOT WATER BOILERS



Features

- Maximum design 160psi, 250°F
- Maximum operating 135psi, 235°F
- All boilers are manufactured in accordance with the requirements of the A.S.M.E. Boiler and Pressure Vessel Code and A.S.M.E. CSD-1. Each boiler bears the National Board Stamp "H".
- Shell fiberglass insulation thickness minimum 2" (Average thickness min. 3").
- Power range 120kW - 700kW with up to 12 heating stages, depending on model.
- Heating stages controlled by Schneider Electric PID controls.
- One sensor operation - sensor A controls boiler temperature
- Two sensor operation with outdoor reset - sensor A in boiler, sensor B outdoors
- Temperature set point, max heating power limiting, boiler on/off, time scheduling. Max four (4) programmable events per day.
- Space saving vertical design; Move the boiler through standard 32in doors with pallet jack

Standard Equipment of Each Boiler Includes:

- A.S.M.E. pressure relief valve
- One (1) primary high temperature cutoff control with automatic reset and one (1) secondary high temperature cutoff control with manual reset
- One (1) low water cutoff control with manual reset
- PID-step controller with number of heating stages depending on the boiler heating power
- Digital readout of boiler operating parameters
- Magnetic contactors
- Internal branch circuit fusing with high interrupting capacity
- Main supply power distribution block
- Indicator lights for POWER, HEATING, and ALARMS
- Pressure and temperature gauges
- BACnetTM MS/TP and IP and Modbus[®] Communication Interface with Building Automation System (BAS) provided as standard equipment

Applications

- Space Heating
- Water Source Heat Pumps
- Bio-Diesel Reactors
- Tank Heating
- Swimming Pools
- De-Icing

The new HVR - electric hot water boiler series is designed to meet the demands of modern heating equipment, providing as standard equipment multiple communication protocols for communication with the building automation system (BAS), heating power limiting to manage the electrical demand of the facility, a step controller with advanced features to modulate up to 12 boiler heating stages, up to 100kA short circuit current rating of the panel and much more.

Each boiler can be optionally equipped with a solid state SCR controlled modulation heating stage to provide smooth heating power control between individual on/off heating stages and reduction of wear on the contactor used in the on/off switched heating stages. Further all boiler models can be equipped with a high precision power/energy transducer which allows the logging of energy consumed by the boiler and monitoring the power of all voltages and currents in the three-phase power supply. The power/energy transducer also communicates with the step controller, which allows the monitoring of all heating stages for proper function. All boiler models can also be equipped with unfused molded case switches, which allows a simpler and more compact installation in confined places. A complete list of optional equipment is shown on the "Optional Equipment & Accessories", page 7.

Model Number Key

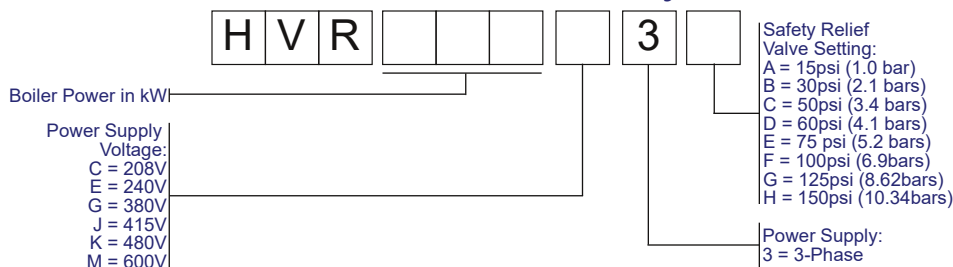

Example: HVR700K3B = HVR-Series hot water boiler, 700kW heating power, power supply 480V, 3ph, safety valve set to 30psi

* Each boiler model requires two (2) power supplies: Heating power and control voltage. Nominal control voltage is 120V AC. Boiler models rated for 380V and 415V are equipped with control voltage transformers that require 220/240V applied to their primary side in order to provide the 120V AC control voltage to the boiler. As an option, all boiler models can be equipped with control voltage transformers so that only the heating power supply needs to be connected to the boiler.

Please note that all information provided within this brochure is approximate and subject to change without notice. Please contact Reimers Electra Steam, Inc. with any questions regarding the specifications or dimensions detailed within this document.

The Controller Module

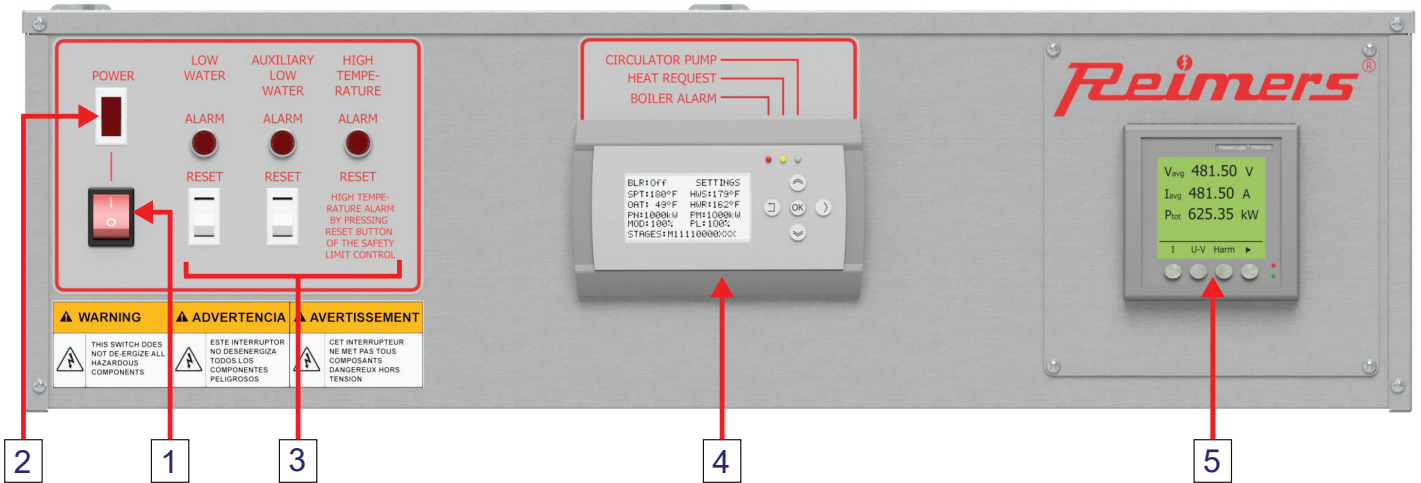

- 1 - CONTROL MASTER SWITCH: As long as the switch is in the OFF-position, all control circuits are de-energized and the boiler can not be accessed remotely by the BAS. As soon as the switch is thrown to the ON-position, the boiler control circuits can be energized from the boiler controller or remotely from the BAS.
- 2 - CONTROL VOLTAGE INDICATOR LIGHT: As soon and as long as the boiler control circuits are energized through the boiler controller or remotely from the BAS, the POWER - indicator light is lit.
- 3 - SAFETY LIMIT CONTROL ALARM LIGHTS AND RESET SWITCHES: The low water-, optional auxiliary low water-, and high temperature alarm lights are lit as long the respective alarms are active. The low water alarm can be reset with the switches on the front panel, whereas the high temperature alarm can be reset with the button installed in the high limit control, located on the rear of the controller enclosure.
- 4 - BOILER CONTROLLER USER INTERFACE: Change settings and monitor the temperature control-, power monitor-, power limiting-, modulating stage- and step controller features on the controller user interface.
- 5 - POWER TRANSDUCER: Monitor and record total Amp-draw, 3-phase voltages, total heating power and energy of the heater circuits. The accurate measured parameters are sent to the BAS through the boiler controller. The measurements of the power transducer can also be used as an option to detect faults in heater circuits such as open circuits or heater stages stuck energized due to welded contactor contacts.

Power Distribution Module

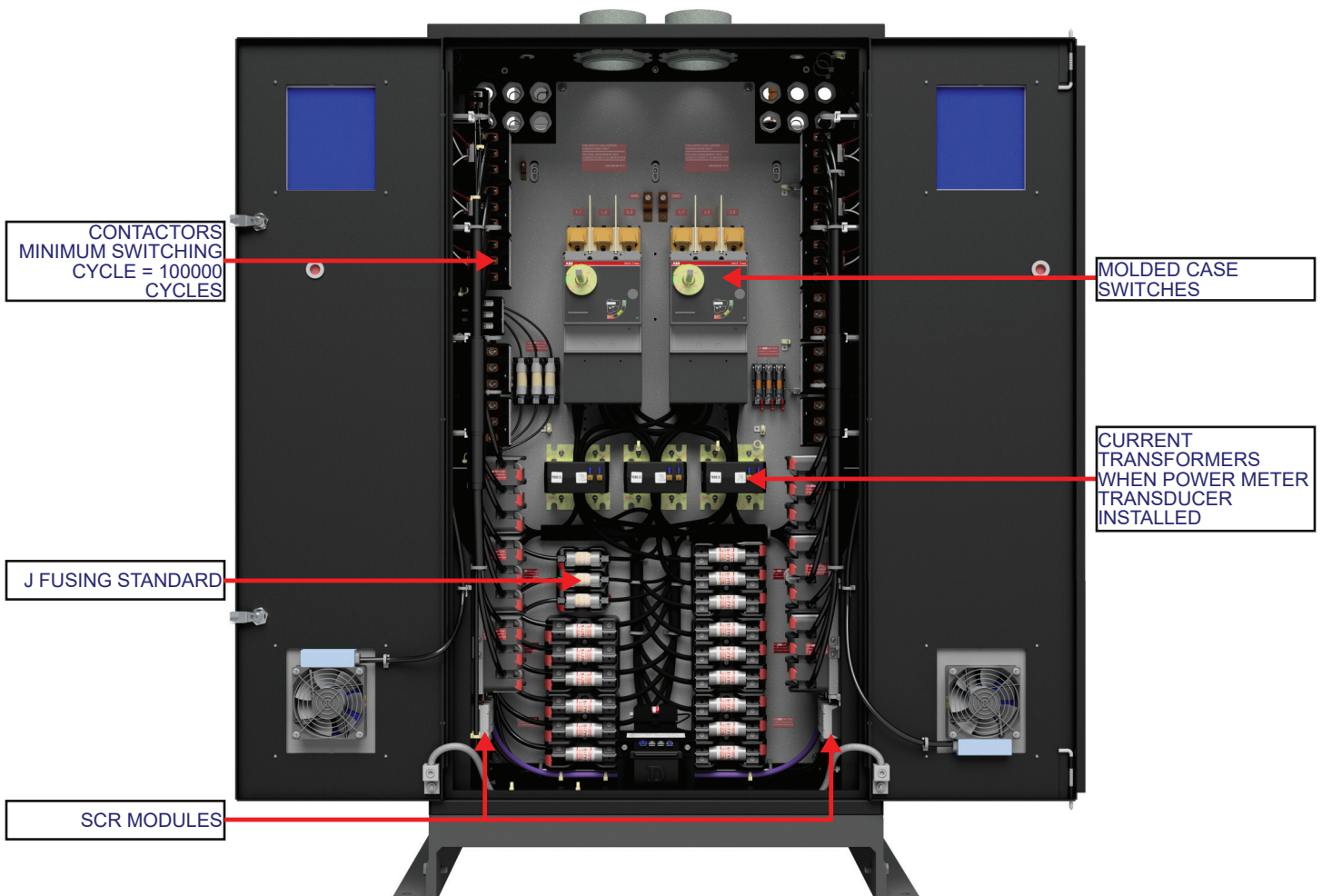

The Controller User Interface

The controller user interface displays all relevant operating parameters in one single home screen. The controller's features are set and configured in a separate **SETTING** menu. All boiler functions can be controlled and monitored either from this user interface or remotely from the **BAS**.

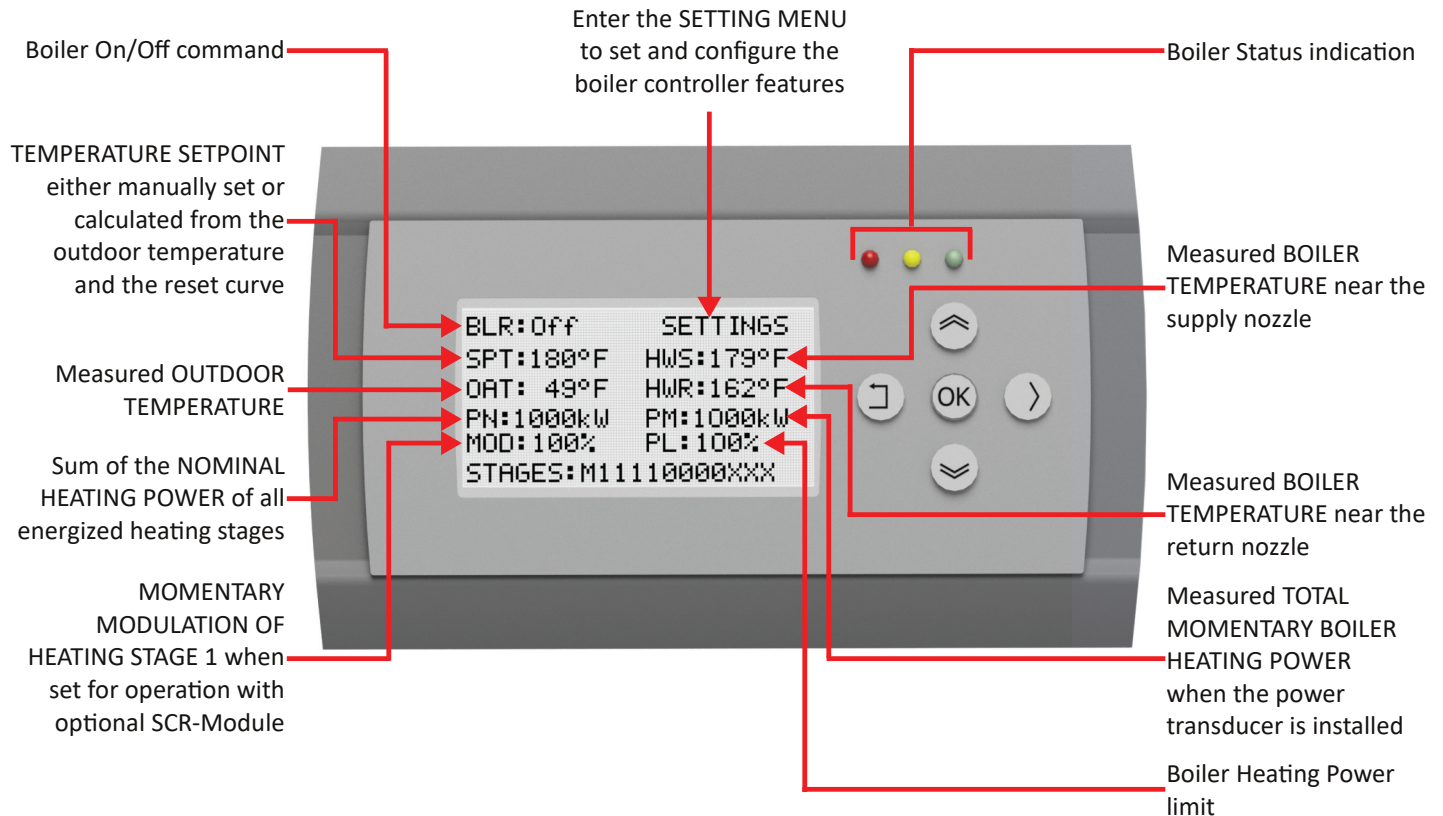

Main Boiler Controller Features

- Boiler Temperature Control:** As long as the outdoor reset feature is disabled, the temperature setpoint (SPT) displayed in the homescreen is a fixed value that can be set between 35°F - 240°F. The temperature control feature calculates the momentary required heating power in a PID-loop, using the readings from a PT1000 type temperature sensor installed near the supply nozzle and the setpoint (SPT). The PID - loop allows the setting of a proportional- (throttling range), integral - and derivative component. The required momentary heating load gets then distributed to a number of to be energized heating stages, depending on the number of enabled stages. As soon as the outdoor reset feature is enabled, the displayed setpoint (SPT) is the value calculated from the measured outdoor temperature (OAT) and the reset curve points. The measured temperature near the return nozzle (HWR) is for monitoring purposes only. It does not influence the temperature control feature.
- Heating Power Measurement Control and Monitoring:** As soon as the optional power transducer is installed, the Amp - draw of the heater circuits, the three phase supply voltages and total heating power can be measured. The momentary measured heating power (PM) is displayed in the homescreen. The step controller feature (see next item) allows the assignment of the nominal heating power to each individual stage. The sum of the heating powers of all momentary energized heating stages (PN) is also displayed in the homescreen. During normal boiler operation with the optional power transducer installed, the controller compares in regular time intervals the actual measured total momentary heating power (PM) to the expected momentary nominal heating power (PN). As soon as a power difference (PN-PM) becomes greater than a programmed parameter in the step controller **SETTING** menu, the controller will indicate an alarm with the RED-LED and the PM-value in the display flashing, indicating that an open circuit was detected in one of the heater branch circuits. With the optional unfused molded case switches installed, equipped with optional shunt trip units, the controller can disconnect the boiler heater power supplies by tripping the molded case switches in case that a power difference (PM-PN) becomes greater than a programmed parameter. This can occur when a contactor in the heater branch circuits remains with closed welded contacts. The boiler heating power can be limited to a percentage of its total installed heating power by setting the (PL) - value in the controller user interface **SETTING** - menu or remotely over the **BAS**. This feature helps the managing of the electrical demand of the facility in which the boiler is installed.
- Step Controller with Advanced Features:** The step controller can be set to operate with a maximum of twelve (12) heating stages. Heating stage 1 can be set in the **SETTINGS**-menu to either ON/OFF- or modulating-operation. Each heater stage can be individually enabled or disabled. When disabled, the respective heater stage is displayed in the user interface home screen with an "X". During normal boiler operation, the enabled heater stages 2 - 12 indicate either "0" when the stage is de-energized or "1" when energized. When heater stage 1 is enabled and set to ON/OFF-operation, it behaves indistinctly to stages 2 - 12. When set to modulating, heater stage 1 displays an "M" and the momentary modulating value is displayed with the (MOD) - value. In order to operate the boiler with heater stage 1 in modulating mode, the optional SCR-module(s) must be installed.
- Scheduling Options:** When the boiler controller is not connected to a **BAS**, it still can perform automatic tasks using the **SCHEDULING** feature in the **SETTING** - menu. The following tasks can be scheduled: **BOILER ON/OFF** (BLR: On or Off), **BOILER SETPOINT** (SPT - value) and **POWER LIMITING** (PL - value).

Electrical Specifications

MODEL	VOLTAGE (V)	POWER SUPPLY 1				POWER SUPPLY 2			
		POWER (kW)	AMPS (A)	ELEMENTS	MAX. SCR-STAGE (OPTIONAL)	POWER (kW)	AMPS (A)	ELEMENTS	
HVR-120	208	120	333.09	6 x 20kW	1 x 20kW				
	208	60	166.54	3 x 20kW	1 x 20kW	60	166.54	3 x 20kW	
	240	120	288.68	6 x 20kW	1 x 20kW				
	240	60	144.34	3 x 20kW	1 x 20kW	60	144.34	3 x 20kW	
	380	120	182.32	6 x 20kW	1 x 40kW				
	380	60	91.16	3 x 20kW	1 x 40kW	60	91.16	3 x 20kW	
	415	120	166.94	6 x 20kW	1 x 40kW				
	415	60	83.47	3 x 20kW	1 x 40kW	60	83.47	3 x 20kW	
	480	120	144.34	6 x 20kW	1 x 40kW				
	480	60	72.17	3 x 20kW	1 x 40kW	60	72.17	3 x 20kW	
	600	120	115.47	6 x 20kW	1 x 40kW				
	600	60	57.74	3 x 20kW	1 x 40kW	60	57.74	3 x 20kW	
HVR-140	208	140	388.60	7 x 20kW	1 x 20kW				
	208	80	222.06	4 x 20kW	1 x 20kW	60	166.54	3 x 20kW	
	240	140	336.79	7 x 20kW	1 x 20kW				
	240	80	192.45	4 x 20kW	1 x 20kW	60	144.34	3 x 20kW	
	380	140	212.71	7 x 20kW	1 x 40kW				
	380	80	121.55	4 x 20kW	1 x 40kW	60	91.16	3 x 20kW	
	415	140	194.77	7 x 20kW	1 x 40kW				
	415	80	111.30	4 x 20kW	1 x 40kW	60	83.47	3 x 20kW	
	480	140	168.39	7 x 20kW	1 x 40kW				
	480	80	96.23	4 x 20kW	1 x 40kW	60	72.17	3 x 20kW	
	600	140	134.72	7 x 20kW	1 x 40kW				
	600	80	76.98	4 x 20kW	1 x 40kW	60	57.74	3 x 20kW	
HVR-160	208	160	444.12	8 x 20kW	1 x 20kW				
	208	80	222.06	4 x 20kW	1 x 20kW	80	222.06	4 x 20kW	
	240	160	384.90	8 x 20kW	1 x 20kW				
	240	80	192.45	4 x 20kW	1 x 20kW	80	192.45	4 x 20kW	
	380	160	243.09	8 x 20kW	1 x 40kW				
	380	80	121.55	4 x 20kW	1 x 40kW	80	121.55	4 x 20kW	
	415	160	222.59	8 x 20kW	1 x 40kW				
	415	80	111.30	4 x 20kW	1 x 40kW	80	111.30	4 x 20kW	
	480	160	192.45	8 x 20kW	1 x 40kW				
	480	80	96.23	4 x 20kW	1 x 40kW	80	96.23	4 x 20kW	
	600	160	153.96	8 x 20kW	1 x 40kW				
	600	80	76.98	4 x 20kW	1 x 40kW	80	76.98	4 x 20kW	
HVR-180	208	180	499.63	9 x 20kW	1 x 20kW				
	208	100	277.57	5 x 20kW	1 x 20kW	80	222.06	4 x 20kW	
	240	180	433.01	9 x 20kW	1 x 20kW				
	240	100	240.56	5 x 20kW	1 x 20kW	80	192.45	4 x 20kW	
	380	180	273.48	9 x 20kW	1 x 40kW				
	380	100	151.93	5 x 20kW	1 x 40kW	80	121.55	4 x 20kW	
	415	180	250.42	9 x 20kW	1 x 40kW				
	415	100	139.12	5 x 20kW	1 x 40kW	80	111.30	4 x 20kW	
	480	180	216.51	9 x 20kW	1 x 40kW				
	480	100	120.28	5 x 20kW	1 x 40kW	80	96.23	4 x 20kW	
	600	180	173.21	9 x 20kW	1 x 40kW				
	600	100	96.23	5 x 20kW	1 x 40kW	80	76.98	4 x 20kW	
HVR-200	208	200	555.14	10 x 20kW	1 x 20kW				
	208	100	277.57	5 x 20kW	1 x 20kW	100	277.57	5 x 20kW	
	240	200	481.13	10 x 20kW	1 x 20kW				
	240	100	240.56	5 x 20kW	1 x 20kW	100	240.56	5 x 20kW	
	380	200	303.87	10 x 20kW	1 x 40kW				
	380	100	151.93	5 x 20kW	1 x 40kW	100	151.93	5 x 20kW	
	415	200	278.24	10 x 20kW	1 x 40kW				
	415	100	139.12	5 x 20kW	1 x 40kW	100	139.12	5 x 20kW	
	480	200	240.56	10 x 20kW	1 x 40kW				
	480	100	120.28	5 x 20kW	1 x 40kW	100	120.28	5 x 20kW	
	600	200	192.45	10 x 20kW	1 x 40kW				
	600	100	96.23	5 x 20kW	1 x 40kW	100	96.23	5 x 20kW	

MODEL	VOLTAGE (V)	POWER SUPPLY 1				POWER SUPPLY 2			
		POWER (kW)	AMPS (A)	ELEMENTS	MAX. SCR-STAGE	POWER (kW)	AMPS (A)	ELEMENTS	
HVR-220	208	120	333.09	6 x 20kW	1 x 20kW	100	277.57	5 x 20kW	
	240	220	529.24	11 x 20kW	1 x 20kW				
	240	120	288.68	6 x 20kW	1 x 20kW	100	240.56	5 x 20kW	
	380	220	334.26	11 x 20kW	1 x 40kW				
	380	120	182.32	6 x 20kW	1 x 40kW	100	151.93	5 x 20kW	
	415	220	306.07	11 x 20kW	1 x 40kW				
	415	120	166.94	6 x 20kW	1 x 40kW	100	139.12	5 x 20kW	
	480	220	264.62	11 x 20kW	1 x 40kW				
	480	120	144.34	6 x 20kW	1 x 40kW	100	120.28	5 x 20kW	
	600	220	211.70	11 x 20kW	1 x 40kW				
	600	120	115.47	6 x 20kW	1 x 40kW	100	96.23	5 x 20kW	
HVR-240	208	120	333.09	6 x 20kW	1 x 20kW	120	333.09	6 x 20kW	
	240	120	288.68	6 x 20kW	1 x 20kW	120	288.68	6 x 20kW	
	380	240	364.64	12 x 20kW	1 x 40kW				
	380	120	182.32	6 x 20kW	1 x 40kW	120	182.32	6 x 20kW	
	415	240	333.89	12 x 20kW	1 x 40kW				
	415	120	166.94	6 x 20kW	1 x 40kW	120	166.94	6 x 20kW	
	480	240	288.68	12 x 20kW	1 x 40kW				
	480	120	144.34	6 x 20kW	1 x 40kW	120	144.34	6 x 20kW	
	600	240	230.94	12 x 20kW	1 x 40kW				
	600	120	115.47	6 x 20kW	1 x 40kW	120	115.47	6 x 20kW	
HVR-260	380	260	395.03	13 x 20kW	1 x 40kW				
	380	140	212.71	7 x 20kW	1 x 40kW	120	182.32	6 x 20kW	
	415	260	361.71	13 x 20kW	1 x 40kW				
	415	140	194.77	7 x 20kW	1 x 40kW	120	166.94	6 x 20kW	
	480	260	312.73	13 x 20kW	1 x 60kW				
	480	140	168.39	7 x 20kW	1 x 60kW	120	144.34	6 x 20kW	
	600	260	250.19	13 x 20kW	1 x 60kW				
	600	140	134.72	7 x 20kW	1 x 60kW	120	115.47	6 x 20kW	
HVR-280	380	280	425.42	14 x 20kW	1 x 40kW				
	380	140	212.71	7 x 20kW	1 x 40kW	140	212.71	7 x 20kW	
	415	280	389.54	14 x 20kW	1 x 40kW				
	415	140	194.77	7 x 20kW	1 x 40kW	140	194.77	7 x 20kW	
	480	280	336.79	14 x 20kW	1 x 60kW				
	480	140	168.39	7 x 20kW	1 x 60kW	140	168.39	7 x 20kW	
	600	280	269.43	14 x 20kW	1 x 60kW				
	600	140	134.72	7 x 20kW	1 x 60kW	140	134.72	7 x 20kW	
HVR-300	380	300	455.80	15 x 20kW	1 x 40kW				
	380	160	243.09	8 x 20kW	1 x 40kW	140	212.71	7 x 20kW	
	415	300	417.36	15 x 20kW	1 x 40kW				
	415	160	222.59	8 x 20kW	1 x 40kW	140	194.77	7 x 20kW	
	480	300	360.84	15 x 20kW	1 x 60kW				
	480	160	192.45	8 x 20kW	1 x 60kW	140	168.39	7 x 20kW	
	600	300	288.68	15 x 20kW	1 x 60kW				
	600	160	153.96	8 x 20kW	1 x 60kW	140	134.72	7 x 20kW	
HVR-320	380	320	486.19	16 x 20kW	1 x 40kW				
	380	160	243.09	8 x 20kW	1 x 40kW	160	243.09	8 x 20kW	
	415	320	445.19	16 x 20kW	1 x 40kW				
	415	160	222.59	8 x 20kW	1 x 40kW	160	222.59	8 x 20kW	
	480	320	384.90	16 x 20kW	1 x 60kW				
	480	160	192.45	8 x 20kW	1 x 60kW	160	192.45	8 x 20kW	
	600	320	307.92	16 x 20kW	1 x 60kW				
	600	160	153.96	8 x 20kW	1 x 60kW	160	153.96	8 x 20kW	
HVR-340	380	340	516.58	17 x 20kW	1 x 40kW				
	380	180	273.48	9 x 20kW	1 x 40kW	160	243.09	8 x 20kW	
	415	340	473.01	17 x 20kW	1 x 40kW				
	415	180	250.42	9 x 20kW	1 x 40kW	160	222.59	8 x 20kW	
	480	340	408.96	17 x 20kW	1 x 60kW				
	480	180	216.51	9 x 20kW	1 x 60kW	160	192.45	8 x 20kW	
	600	340	327.17	17 x 20kW	1 x 60kW				
	600	180	173.21	9 x 20kW	1 x 60kW	160	153.96	8 x 20kW	

MODEL	VOLTAGE (V)	POWER SUPPLY 1				POWER SUPPLY 2			
		POWER (kW)	AMPS (A)	ELEMENTS	MAX. SCR-STAGE	POWER (kW)	AMPS (A)	ELEMENTS	
HVR-360	380	360	546.96	18 x 20kW	1 x 40kW				
	380	180	273.48	9 x 20kW	1 x 40kW	180	273.48	9 x 20kW	
	415	360	500.83	18 x 20kW	1 x 40kW				
	415	180	250.42	9 x 20kW	1 x 40kW	180	250.42	9 x 20kW	
	480	360	433.01	18 x 20kW	1 x 60kW				
	480	180	216.51	9 x 20kW	1 x 60kW	180	216.51	9 x 20kW	
	600	360	346.41	18 x 20kW	1 x 60kW				
	600	180	173.21	9 x 20kW	1 x 60kW	180	173.21	9 x 20kW	
HVR-380	380	200	303.87	10 x 20kW	1 x 40kW	180	273.48	9 x 20kW	
	415	360	500.83	19 x 20kW	1 x 40kW				
	415	200	278.24	10 x 20kW	1 x 40kW	180	250.42	9 x 20kW	
	480	360	433.01	19 x 20kW	1 x 60kW				
	480	200	240.56	10 x 20kW	1 x 60kW	180	216.51	9 x 20kW	
	600	360	346.41	19 x 20kW	1 x 60kW				
	600	200	192.45	10 x 20kW	1 x 60kW	180	173.21	9 x 20kW	
HVR-400	380	200	303.87	10 x 20kW	1 x 40kW	200	303.87	10 x 20kW	
	415	400	556.48	20 x 20kW	1 x 40kW				
	415	200	278.24	10 x 20kW	1 x 40kW	200	278.24	10 x 20kW	
	480	400	481.13	20 x 20kW	1 x 60kW				
	480	200	240.56	10 x 20kW	1 x 60kW	200	240.56	10 x 20kW	
	600	400	384.90	20 x 20kW	1 x 60kW				
	600	200	192.45	10 x 20kW	1 x 60kW	200	192.45	10 x 20kW	
HVR-420	380	220	334.26	11 x 20kW	1 x 40kW	200	303.87	10 x 20kW	
	415	220	306.07	11 x 20kW	1 x 40kW	200	278.24	10 x 20kW	
	480	420	505.18	21 x 20kW	1 x 60kW				
	480	220	264.62	11 x 20kW	1 x 60kW	200	240.56	10 x 20kW	
	600	420	404.15	21 x 20kW	1 x 60kW				
	600	220	211.70	11 x 20kW	1 x 60kW	200	192.45	10 x 20kW	
HVR-440	380	220	334.26	11 x 20kW	1 x 40kW	220	334.26	11 x 20kW	
	415	220	306.07	11 x 20kW	1 x 40kW	220	306.07	11 x 20kW	
	480	440	529.24	22 x 20kW	1 x 60kW				
	480	220	264.62	11 x 20kW	1 x 60kW	220	264.62	11 x 20kW	
	600	440	423.39	22 x 20kW	1 x 60kW				
	600	220	211.70	11 x 20kW	1 x 60kW	220	211.70	11 x 20kW	
HVR-460	380	240	364.64	12 x 20kW	1 x 40kW	220	334.26	11 x 20kW	
	415	240	333.89	12 x 20kW	1 x 40kW	220	306.07	11 x 20kW	
	480	460	553.29	23 x 20kW	1 x 60kW				
	480	240	288.68	12 x 20kW	1 x 60kW	220	264.62	11 x 20kW	
	600	460	442.64	23 x 20kW	1 x 60kW				
	600	240	230.94	12 x 20kW	1 x 60kW	220	211.70	11 x 20kW	
HVR-480	380	240	364.64	6x40kW	1 x 40kW	240	364.64	6x40kW	
	415	240	333.89	6x40kW	1 x 40kW	240	333.89	6x40kW	
	480	240	288.68	12 x 20kW	1 x 60kW	240	288.68	12 x 20kW	
	600	480	461.88	24 x 20kW	1 x 60kW				
	600	240	230.94	12 x 20kW	1 x 60kW	240	230.94	12 x 20kW	
HVR-500	480	260	312.73	13 x 20kW	1 x 60kW	240	288.68	12 x 20kW	
	600	500	481.13	25 x 20kW	1 x 60kW				
	600	260	250.19	13 x 20kW	1 x 60kW	240	230.94	12 x 20kW	
HVR-510	380	270	410.22	18 x 15kW	1 x 45kW	240	364.64	16 x 15kW	
	415	270	375.63	18 x 15kW	1 x 45kW	240	333.89	16 x 15kW	
HVR-520	480	260	312.73	13 x 20kW	1 x 60kW	260	312.73	13 x 20kW	
	600	520	500.37	26 x 20kW	1 x 60kW				
	600	260	250.19	13 x 20kW	1 x 60kW	260	250.19	13 x 20kW	
HVR-535	380	270	410.22	18 x 15kW	1 x 45kW	265	402.63	15x15kW +	
	415	270	375.63	18 x 15kW	1 x 45kW	265	368.67	15x15kW +	
HVR-540	480	280	336.79	14 x 20kW	1 x 60kW	260	312.73	13 x 20kW	
	600	540	519.62	27 x 20kW	1 x 60kW				
	600	280	269.43	14 x 20kW	1 x 60kW	260	250.19	13 x 20kW	
HVR-560	480	280	336.79	14 x 20kW	1 x 60kW	280	336.79	14 x 20kW	
	600	540	519.62		1 x 60kW				
	600	280	269.43	14 x 20kW	1 x 60kW	280	269.43	14 x 20kW	

MODEL	VOLTAGE (V)	POWER SUPPLY 1				POWER SUPPLY 2			
		POWER (kW)	AMPS (A)	ELEMENTS	MAX. SCR-STAGE	POWER (kW)	AMPS (A)	ELEMENTS	
HVR-580	480	300	360.84	15 x 20kW	1 x 60kW	280	336.79	14 x 20kW	
	600	580	558.11	29 x 20kW	1 x 60kW				
	600	300	288.68	15 x 20kW	1 x 60kW	280	269.43	14 x 20kW	
HVR-600	480	300	360.84	15 x 20kW	1 x 60kW	300	360.84	15 x 20kW	
	600	300	288.68	30 x 20kW	1 x 60kW	300	288.68		
HVR-620	480	320	384.90	15 x 20kW	1 x 60kW	300	360.84	15 x 20kW	
	600	320	307.92	16 x 20kW	1 x 60kW	300	288.68		
HVR-640	480	320	384.90	16 x 20kW	1 x 60kW	320	384.90	16 x 20kW	
	600	320	307.92	16 x 20kW	1 x 60kW	320	307.92	16 x 20kW	
HVR-660	480	340	408.96	17 x 20kW	1 x 60kW	320	384.90	16 x 20kW	
	600	340	327.17	17 x 20kW	1 x 60kW	320	307.92	16 x 20kW	
HVR-680	480	340	408.96	17 x 20kW	1 x 60kW	340	408.96	17 x 20kW	
	600	340	327.17	17 x 20kW	1 x 60kW	340	327.17	17 x 20kW	
HVR-700	480	360	433.01	18 x 20kW	1 x 60kW	340	408.96	17 x 20kW	
	600	360	346.41	18 x 20kW	1 x 60kW	340	327.17	17 x 20kW	

Optional Equipment and Accessories

- OPT1010:** Optional transformer .5KVA
 - OPT1011:** Optional transformer 1.5KVA
 - OPT1037:** Provide optical and acoustical alarm indication.
 - OPTMM150:** Auxiliary low water cut-off water column with float control
 - OPT1012:** Auxiliary low water cut-off water column with conductive type probe fitting
 - OPT:** SCR modulated heating stage.
 - OPT:** Power Transducer/Meter.
 - OPT-316SH:** SS 316 sheathing heating element option
 - OPT-INCOLOY:** Incoloy sheathing heating element option
 - 02512:** Flow switch MM FS4-3
- High Short Circuit Rating (SCCR) upon request.

OPTMM150



OPT1012



HVR 120 - 420 OVERALL DIMENSIONS - LEFT RETURN ORIENTATION

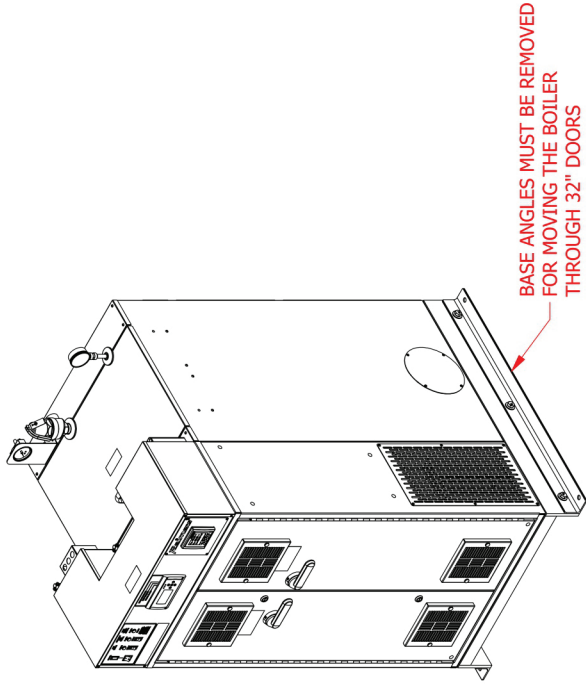

BASE ANGLES MUST BE REMOVED FOR MOVING THE BOILER THROUGH 32" DOORS

HEATING ELEMENT ACCESS COVER

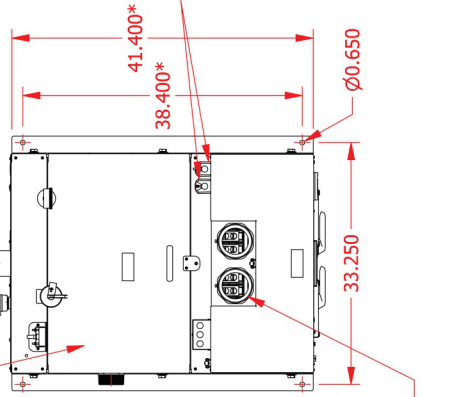

SAFETY LIMIT CONTROLS

* = FOR BOILER MODELS 120-240 SUBTRACT 3.5"

PRESSURE VESSEL CAPACITY:

HVR 120-240 = 42.6 GALLONS

HVR 260-420 = 61.7 GALLONS

20°F TEMPERATURE RISE:

0.3418 GAL/MIN PER KW BOILER HEATING POWER

APPROXIMATE SHIPPING WEIGHT: CONTACT FACTORY

POWER SUPPLY CONDUIT CONNECTIONS
2 X 4in OR 4 X 2.5in

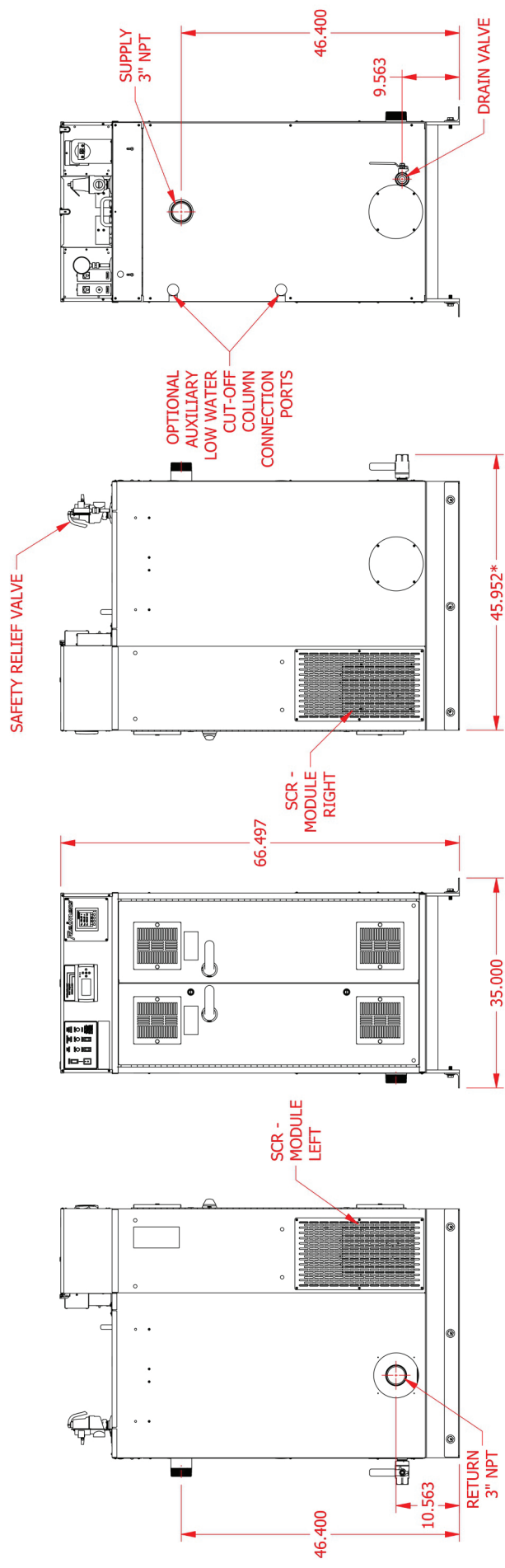

SAFETY RELIEF VALVE

OPTIONAL AUXILIARY LOW WATER CUT-OFF COLUMN CONNECTION PORTS

SCR - MODULE LEFT

SCR - MODULE RIGHT

HVR 120 - 420 OVERALL DIMENSIONS - REAR RETURN ORIENTATION

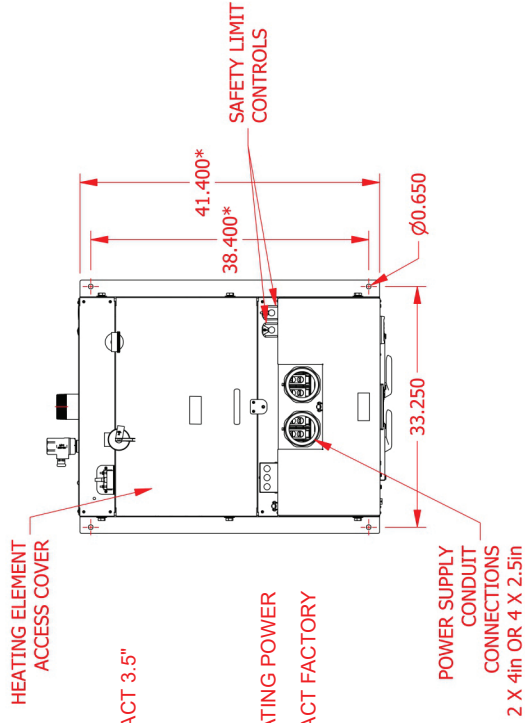
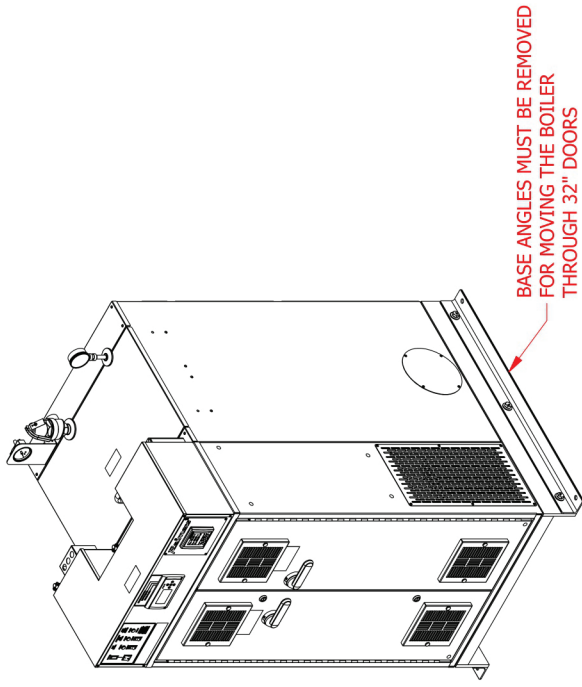

* = FOR BOILER MODELS 120-240 SUBTRACT 3.5"
 PRESSURE VESSEL CAPACITY:
 HVR 120-240 = 42.6 GALLONS
 HVR 260-420 = 61.7 GALLONS
 20°F TEMPERATURE RISE:
 0.3418 GAL/MIN PER kW BOILER HEATING POWER
 APPROXIMATE SHIPPING WEIGHT: CONTACT FACTORY

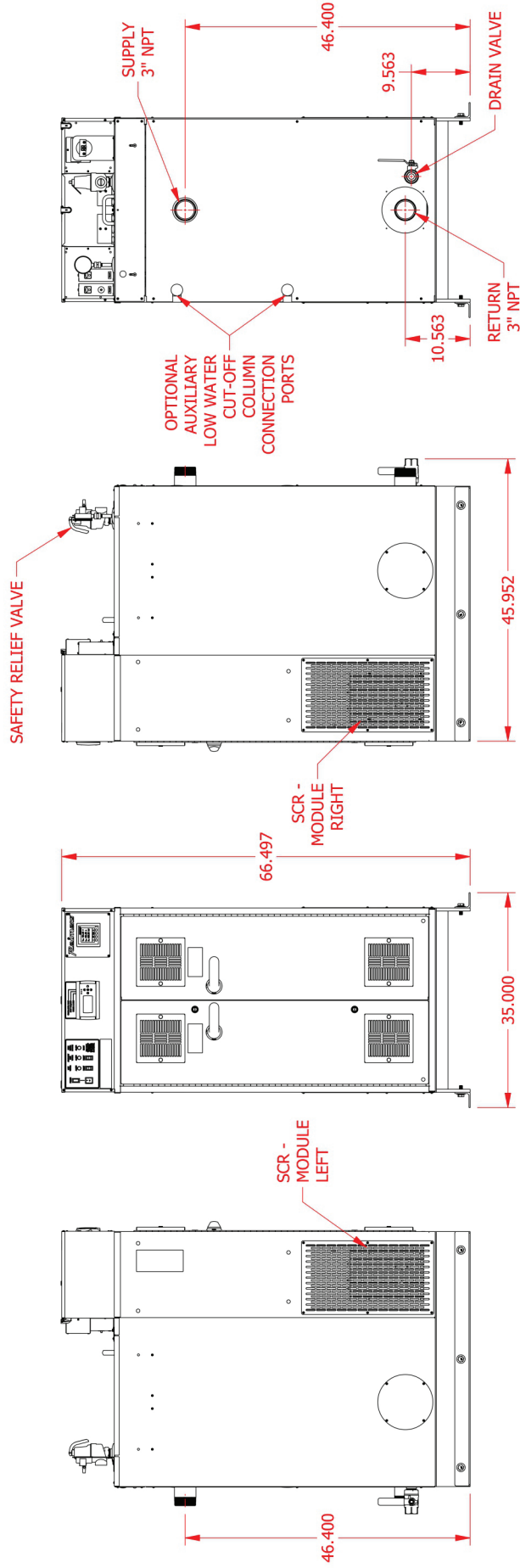

HVR 120 - 420 OVERALL DIMENSIONS - RIGHT RETURN ORIENTATION

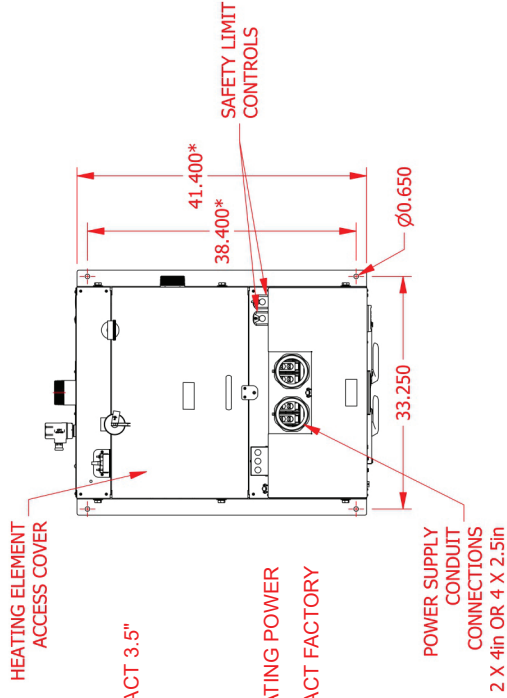
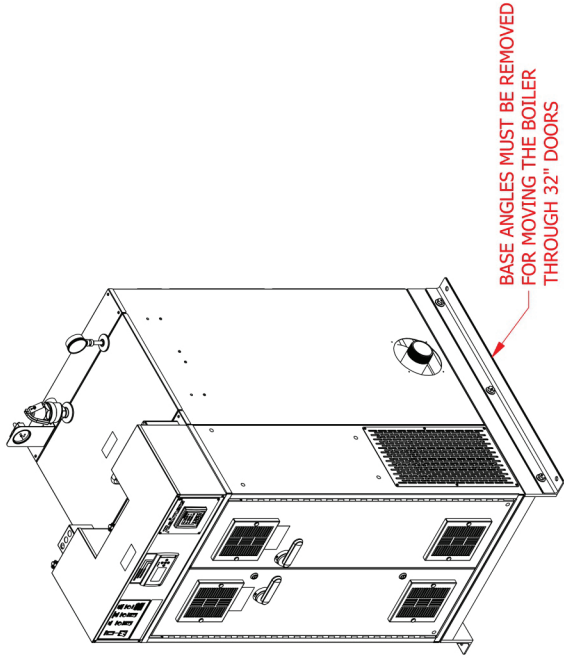

* = FOR BOILER MODELS 120-240 SUBTRACT 3.5"

PRESSURE VESSEL CAPACITY:

HVR 120-240 = 42.6 GALLONS

HVR 260-420 = 61.7 GALLONS

20°F TEMPERATURE RISE:

0.3418 GAL/MIN PER kW BOILER HEATING POWER

APPROXIMATE SHIPPING WEIGHT: CONTACT FACTORY

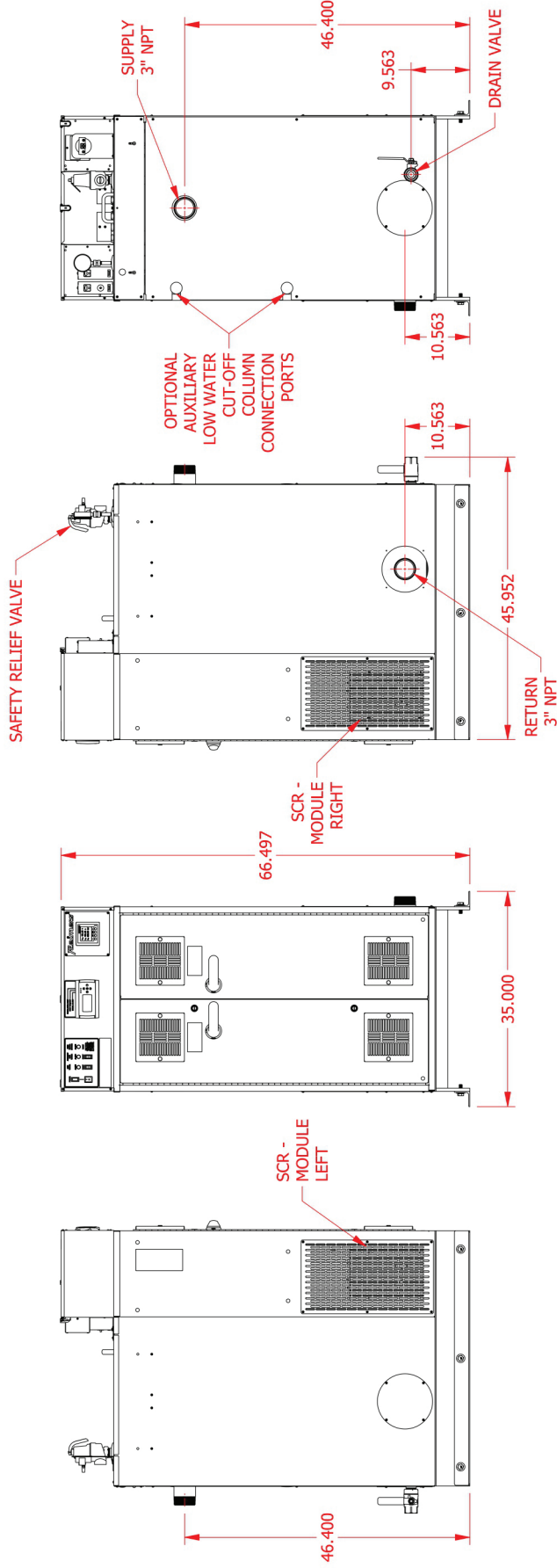

HVR 440- 700 OVERALL DIMENSIONS - REAR FLANGE ORIENTATION

PRESSURE VESSEL CAPACITY: 90.1 GALLONS

20°F TEMPERATURE RISE:

0.3418 GAL/MIN PER KW BOILER HEATING POWER

APPROXIMATE SHIPPING WEIGHT: CONTACT FACTORY

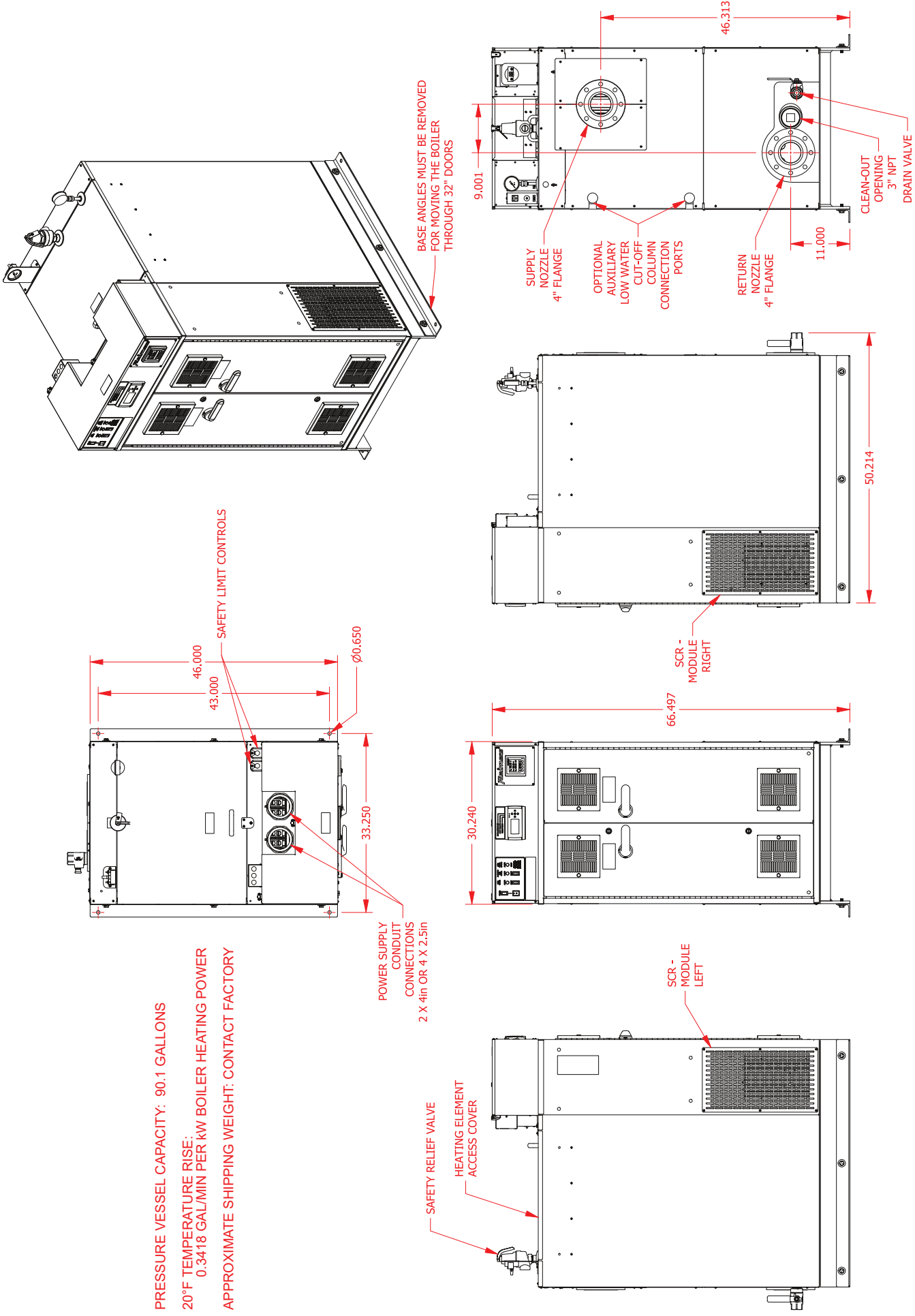

HVR 440- 700 OVERALL DIMENSIONS - RIGHT SIDE FLANGE ORIENTATION

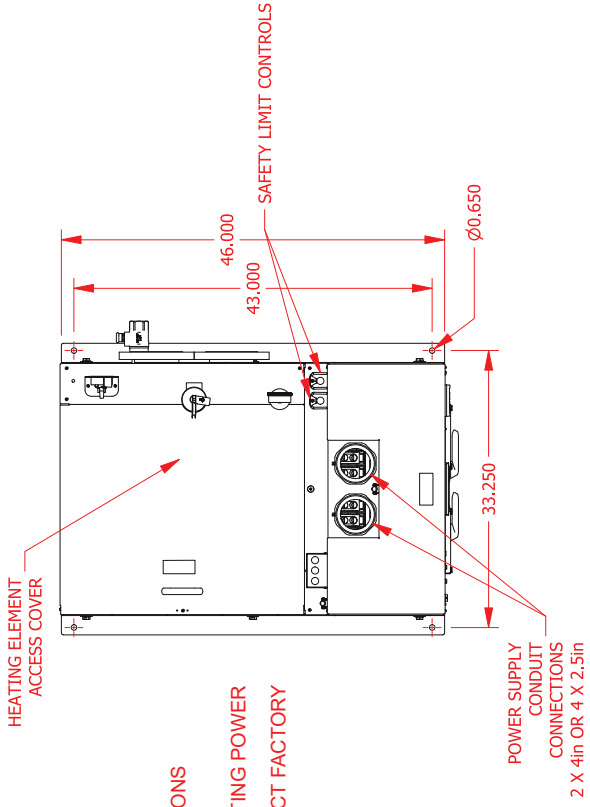
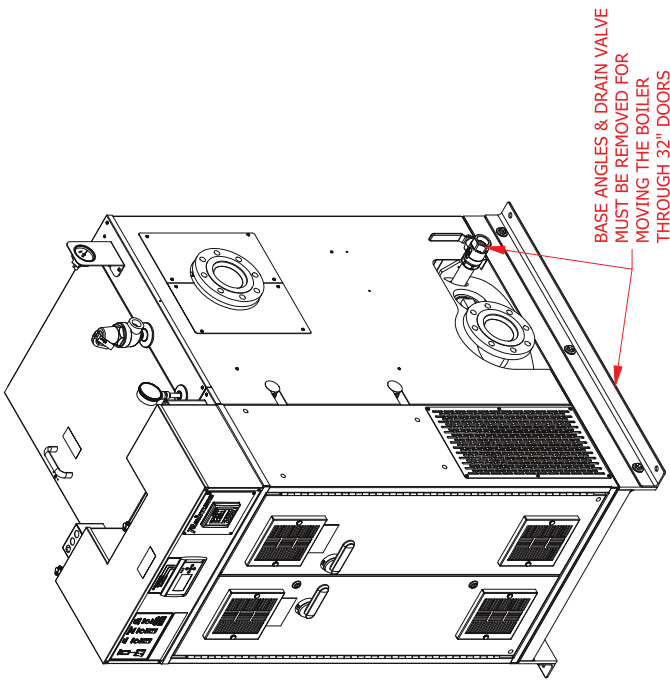

PRESSURE VESSEL CAPACITY: 90.1 GALLONS

20°F TEMPERATURE RISE:

0.3418 GAL/MIN PER KW BOILER HEATING POWER

APPROXIMATE SHIPPING WEIGHT: CONTACT FACTORY

