

# Installation Procedure

## Cryostation 200 PT

Version: 1.1  
May 2026

[www.montanainstruments.com](http://www.montanainstruments.com)  
[support@montanainstruments.com](mailto:support@montanainstruments.com)

MONTANA INSTRUMENTS®

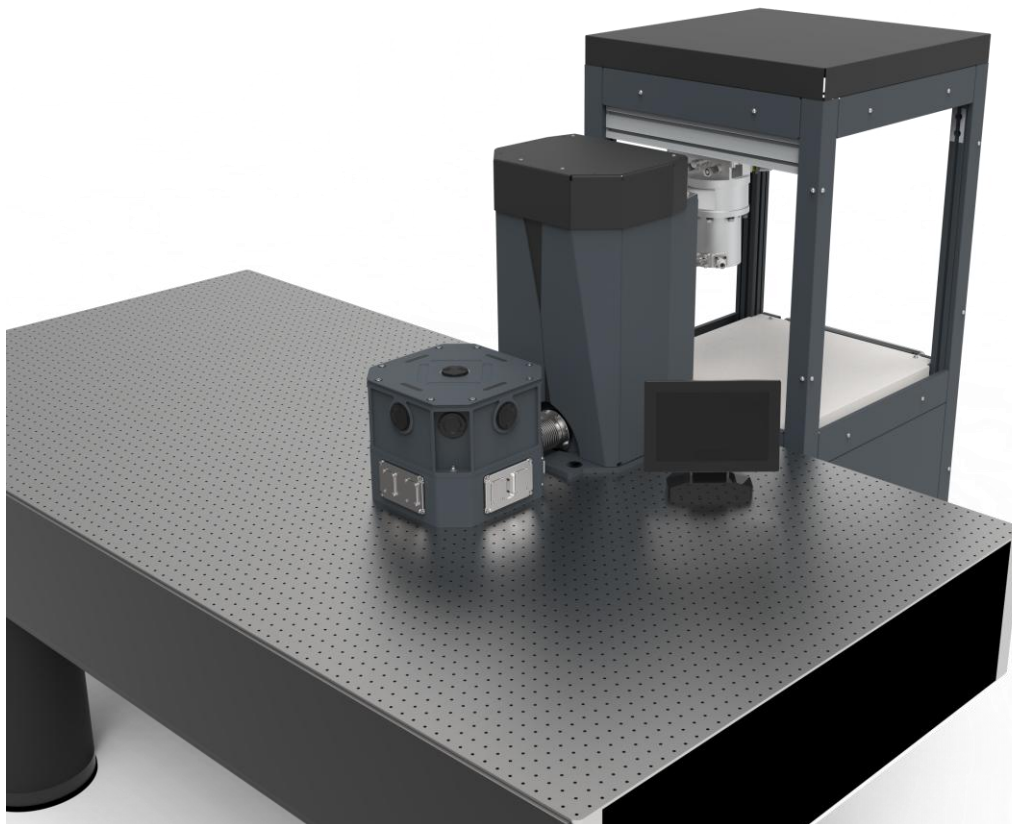



Specifications and product information listed in this document are accurate at the time of publishing for a standard system. Options, custom designs, and other modifications may cause slight differences. Future design changes to the system, including software updates, may change.

© Montana Instruments® Corporation, All Rights Reserved

No part of this publication may be reproduced, distributed, or transmitted in any form or by any means, including photocopying, recording, or other electronic or mechanical methods, without the prior written permission of Montana Instruments.

Montana Instruments, CryoAdvance, and Cryostation are trademarks of Montana Instruments Corporation. Other brand names used are the property of their respective owners.

## Table of Contents

<b>Section 1 - Preface</b> .....	<b>5</b>
<b>1.1 Conventions Used in this Manual</b> .....	<b>5</b>
1.1.1 Abbreviations.....	6
1.1.2 International System of Units (SI) Symbols .....	6
1.1.3 System of Imperial Units Symbols .....	6
1.1.4 Explanation of Safety Warnings.....	7
1.1.5 Graphical Symbols.....	8
<b>1.2 General Hazard &amp; Safety Information</b> .....	<b>9</b>
<b>1.3 Technical Support Information</b> .....	<b>12</b>
1.3.1 Warranty & Repairs.....	12
1.3.2 Accessories & Replacement Parts.....	13
1.3.3 Contact Details .....	13
<b>Section 2 - System Installation &amp; Handling</b> .....	<b>14</b>
<b>2.1 Shipping Weights &amp; Dimensions</b> .....	<b>14</b>
<b>2.2 Packaging Contents</b> .....	<b>14</b>
<b>2.3 Component Placement and Layout Plan</b> .....	<b>16</b>
<b>2.4 Unpacking the Components</b> .....	<b>19</b>
2.4.1 Unpacking the Compressor.....	20
2.4.2 Unpacking the Cryostation.....	20
2.4.3 Unpacking the System Rack.....	23
<b>2.5 Installing the Cryostation</b> .....	<b>25</b>
2.5.1 Mounting the Cryostation to the Optical Table .....	25
2.5.2 Connecting System Cables and Power .....	28
2.5.3 Removing the Shipping Supports.....	46
<b>2.6 Initializing the Cryostation</b> .....	<b>47</b>

# Section 1 - Preface

## **WARNING**

### **Read all instructions before using this product**

All users must read and understand this manual and all other safety instructions before using the equipment. Retain these instructions for future reference.

This manual is intended for users of the Montana Instruments products and systems described herein. Users include anyone who may physically interact with the system or peripheral equipment, including installing, setting up, or configuring the system or anyone who may operate system components via operating panels, the supplied user interface, or remote interfaces.

This manual may be used by facilities personnel to determine infrastructure requirements in the room or building where the equipment will be installed.

This manual should be referenced by authorized service personnel for important safety and hazard information and other product restrictions.

## 1.1 Conventions Used in this Manual

The following style conventions are used in this document:

- A vertical bar ( | )
  - Indicates alternative selections. The bar may be used in place of "and" or "or."
- Alphanumeric List (1., 2., 3...| a., b., c...)
  - Indicates instructions or actions which should be completed in a specific ordered sequence.
- Bullet List (• | ° | -)
  - Indicates instructions, commands, or additional information about an action.
  - May alternatively be used for unordered lists of materials or additional reference notes.
- Courier Font
  - Indicates a label or indicator on a physical product or part.
  - Indicates a system output, such as a display reading.
  - May also be used for URLs, file paths, file names, scripting language, prompts, or syntax.

### 1.1.1 Abbreviations

The following abbreviations may be used:

- ACM: Ancillary Control Module
- CAN: Controller Area Network
- DMM: Digital Multimeter
- HDMI: High-Definition Multimedia Interface
- MI: Montana Instruments
- PCB: Printed Circuit Board
- TCM: Temperature Control Module
- UI: User Interface
- UPS: Uninterruptible Power Supply
- USB: Universal Serial Bus
- VNC: Virtual Network Computing

### 1.1.2 International System of Units (SI) Symbols

- C: Celsius
- cm: Centimeter
- K: Kelvin
- kg: Kilogram
- m: Meter
- mK: Millikelvin
- MPa: Megapascal
- mTorr: Millitorr
- mW: Milliwatt
- s: Second

### 1.1.3 System of Imperial Units Symbols

- ft, ' : Foot
- in, " : Inch

#### **1.1.4 Explanation of Safety Warnings**

Safety and hazard information includes terms, symbols, warnings, and instructions used in this manual or on the equipment to alert users to precautions in the care, use, and handling of the system. The following hazard levels and information are considered:

 **DANGER**

**Serious personal injury**

Imminent hazards which, if not avoided, will result in serious injury or death.

 **WARNING**

**Serious personal injury**

Potential hazards which, if not avoided, could result in serious injury or death.

 **CAUTION**

**Possible personal injury**

Potential hazards which, if not avoided, could result in minor or moderate injury.

**NOTICE**

**Command or Product Safety Notice**







Potential hazards which, if not avoided, could result in product damage.

**» NOTE**

Points of particular interest for more efficient or convenient equipment operation; additional information or explanation.

### 1.1.5 Graphical Symbols

The following symbols may be used in diagrams, supporting text, and on physical parts:

	Hazard Alert: General Warning		Hazard Alert: High Voltage
	Hazard Alert: Laser Radiation		HDMI port
	CAN bus module		USB port

## 1.2 General Hazard & Safety Information

The following descriptions are of general hazards and unsafe practices that may result in product damage, severe injury, or death.

- The products, parts, and components in this manual are to be serviced by authorized Montana Instruments service representatives only. Failure to do so will void the warranty and may damage the product and/or create a safety hazard.
- Only use all components provided for the intended purpose described herein.
- If the equipment or any component is used or modified in a manner not specified by the manufacturer, the protection provided by the equipment may be impaired.

The following hazards may be typical for this product:

### **WARNING**

#### **Risk of injury when lifting or moving system components**

System components, including standalone equipment and installed assemblies, may be heavy.

- Use caution when lifting or moving equipment or assemblies. Ensure proper lifting principles are used to avoid injury.
- Equipment or assemblies >20 kg should always be lifted by two or more people or with a suitable lifting device.

#### **Risk of injury due to sharp edges**

- The interior of the enclosure contains sheet metal parts that may have sharp edges.
- When working inside the enclosure (authorized service personnel only), exercise caution to avoid getting cut by these edges.

### **WARNING**

**High voltage: danger of electric shock**

Electric shocks and burns from capacitor discharge or power circuits could lead to serious injury or death.

- Before turning on any power supply, the ground prong of the power cord plug must be properly connected to the ground connector of the wall outlet. The wall outlet must have a third prong or must be properly connected to an adapter that complies with these safety requirements.
- Only use replacement power cords or power plugs with the same polarity and power rating as that of the original ones. Do NOT use inadequately rated cables.
- If the equipment or the wall outlet is damaged, the protective grounding could be disconnected.
- Do NOT use damaged equipment until its safety has been verified by authorized personnel.
- Do NOT disconnect or tamper with the operation of the protective earth terminal inside or outside the apparatus.
- Before accessing the enclosure or when otherwise servicing the unit (authorized service personnel only), completely power down the system and unplug the power cable.
- If power must be applied to diagnose issues or otherwise, a grounding strap must be applied to the arm interfacing internal components.

**NOTICE**

**Only clean exterior surfaces with acceptable fluids**

- Only use deionized water, glass cleaner, or isopropyl alcohol to clean the exterior surfaces of any enclosure. Do NOT use any volatile chemicals other than isopropyl alcohol.
- Apply fluid to a clean, lint-free cloth and wipe the surface with a cloth. Do NOT apply fluid directly to any surfaces or enclosures.

 **WARNING**

**Risk of serious injury due to hazards associated with cryocooling**

All personnel working with the system must be aware of the potential hazards associated with cryocooling.

- Personnel working with the system should be trained in emergency measures that may be required in the event of an accident.

**Risk of suffocation due to potential asphyxiates.**

Nitrogen (N<sub>2</sub>) and Helium (He) are potential asphyxiates if released into an enclosed area with poor ventilation. A decrease in air oxygen content can be caused by leaks.

- Ensure that proper tubing is used and good connections are made at each connection point to prevent the release of these gases.

**Risk of explosion due to high pressure if the system is not allowed to vent properly.**

- Never bolt or otherwise fasten the lid of the sample chamber closed. The lid acts as a safety pressure release in the event of high-pressure accumulation in the Cryostation.

**Risk of cold contact burns.**

- Parts of this system are very cold and may cause severe burns to the skin.
- Allow components to warm up to room temperature before touching. If contact occurs, consult a physician immediately.

**NOTICE**

**Take care when moving the Cryostation**

- Do NOT tilt the Cryostation more than 45 degrees. Inverting the Cryostation will cause damage.
- The Cryostation and sample chamber are a single unit. The attached sample chamber must be supported at all times. Do NOT lift the Cryostation by the sample chamber.
- Do NOT lift the Cryostation by the cryocooler tube or the top of the main body enclosure.
- The Cryostation ships with red locking plugs and a shipping support to prevent damage to sensitive components. Do NOT remove these until after the unit has been attached to the table.

**Take care when moving the compressor**

- Do NOT tilt the compressor. Doing so may damage the unit.
- The compressor is on casters for moving. Ensure casters are locked before operating.

**Risk of product damage due to improper use**

- Never disconnect the vacuum hose while the temperature of any stage of the Cryostation is below 285 K.
- Never open the case or vent valves when the temperature of any stage is below 285 K.
- Only use dry nitrogen gas with the Cryostation. Do NOT substitute other gases for system venting.
- Avoid using any material in the sample chamber that may outgas or otherwise contaminate the optical windows and Cryostation surfaces.
- When manually operating heaters, monitor the Stage 1 and Stage 2 temperatures to ensure these temperatures do NOT rise above 350 K. Temperatures above 350 K may damage critical components within the system.

**Peripheral cards must not exceed 600 W to avoid product damage**

- The system control unit can supply a maximum power of 600 W across all installed peripheral cards. Ensure the cumulative power of all installed peripheral cards (maximum power rating of all cards added together) does not exceed 600 W.

**Transportation and installation**

- When not in a rack unit, the enclosure should not be stacked on any other equipment, nor should other equipment be placed on it.
- Allow 8 cm minimum clearance from any ventilated face (sides, front) and 20 cm clearance in the rear for cables and hoses.
- Do NOT move the unit while operational. Remove all cables prior to moving. Lift the enclosure by using both handles on the front face.

## 1.3 Technical Support Information

Any technical questions or issues with the system that cannot be resolved with the information in this manual should be referred to an authorized Montana Instruments service representative.

### 1.3.1 Warranty & Repairs

If the system or parts need to be returned to the Montana Instruments factory or an authorized service center for repair or service, contact an authorized service representative for a return merchandise authorization (RMA) number and instructions on returning the unit.

For a copy of the Limited Warranty Agreement, visit:

<https://www.montanainstruments.com/support/warranty-information>

### 1.3.2 Accessories & Replacement Parts

Only use cables, hoses, accessories, and parts provided or approved by the manufacturer. Follow all instructions for proper installation or replacement.

- To order spare or replacement parts, please contact your local service representative.
- To order new accessories or options, or for more information on other Montana Instruments products and technologies, please contact your local sales representative.

### 1.3.3 Contact Details

For a complete list of sales and service centers visit: [www.montanainstruments.com/Contact](http://www.montanainstruments.com/Contact)

#### North American Authorized Service

---

- M-F 8:30am-5pm MST | Call: +1.406.551.2796
- Email: [support@montanainstruments.com](mailto:support@montanainstruments.com)

#### North American Sales

---

- M-F 8:30am-5pm MST | Call: +1.406.551.2796
- Email: [sales@montanainstruments.com](mailto:sales@montanainstruments.com)

#### International Sales & Authorized Service

---

- Visit <https://www.montanainstruments.com/contact> for contact information for your local representative.

## Section 2 - System Installation & Handling

### 2.1 Shipping Weights & Dimensions

The system will arrive on 3 pallets. The typical weights and dimensions of the standard system, as packed, are listed in the table below.

	<b>Pallet 1</b>	<b>Pallet 2</b>	<b>Pallet 3</b>
Components	Compressor	Cryostation	Full Cart (Cart, System and Vacuum Control Units)
Pallet Dimensions (L x W x H)	27 x 24 x 31 in. [69 x 61 x 79 cm]	48 x 32 x 30 in. [122 x 82 x 77 cm]	30.5 x 39 x 71 in. [66 x 66 x 178 cm]
Weight	275 [125 kg]	450 lbs [205 kg]	700 lbs [318 kg]

#### **WARNING**

##### **Use extreme caution when handling the shipment**

A lift or crane is required to move the Cryostation portion of the system. Refer to the appropriate [system user manual](#) for important instructions regarding the safe handling of system components.

### 2.2 Packaging Contents

The system will arrive on 3 pallets, depending on the options purchased. Depending on the configuration, the items below may differ. Additional purchased options may be pre-integrated into the sample chamber or packaged separately. Refer to the shipment packing list for more details.

#### **Compressor Box – Pallet 1**

- Helium Compressor

#### **Cryostation Box – Pallet 2**

- Cryostation and Sample Chamber (single unit) with pre-installed options (depending on the configuration ordered)
- User touchscreen
- Helium Hoses (2): SUPPLY & RETURN

- Vacuum Hose
- Power cables

### Full System Cart– Pallet 3

- System Control Unit with pre-installed peripheral cards (depending on the configuration ordered)
- Vacuum Control Unit
- System cart

### All Cables & Hoses

- 2x C13 System Control and Vacuum Control Units
- 4-socket to 4-pin circular M-F connector cable: Compressor to Cryocooler Head
- DSUB9 F-F serial cable: System Control to Compressor RS232 communication
- HD44 M-F cable: System Control to Vacuum Control
- 2x D38999 F-M: TCM to Cryostation control
- USB & HDMI cables: for the User Interface Touchscreen Display
- Ethernet network cable
- Nitrogen hose

### Accessory Kit

Tweezers & pick tool
Hex Wrenches: 1.27mm, 1.5mm, 2mm, 2.5mm, 4mm, 5mm, and 3/16"
Apiezon® N-grease: <i>for cryogenic thermal connections only</i>
Apiezon® L-grease: <i>for lubricating O-rings only</i>
GE Varnish Adhesive (VGE): <i>for wires or samples within 4 K space</i>
Kapton® Tape: <i>for wire insulation</i>
Unwaxed Dental Floss: <i>for wire management</i>
KF-25 to VCO adapter: <i>for vacuum leak testing</i>
Spare VCO O-rings
Fischer Connector Strip: <i>for custom connections</i>
Assortment of spare screws
Window tool: <i>for removing vacuum window retaining rings</i>
Extraction tool for SMP coax cables
Helium purge adaptor and recharge adaptor
Coax SMP extraction tool
Additional custom components (if purchased)

## 2.3 Component Placement and Layout Plan

Before installing the required wall power, it is recommended to pre-plan the placement of components in the lab space.

- For optimal vibrational performance, the Cryostation (including the sample chamber) should be mounted to an optical table, but any flat, level and a stable surface can be used.
- Cart - Allow for 24 in [60 cm] clearance on front of cart for power. Orientation of cart can be modified prior to order placement for your lab environment, contact Montana Instruments to discuss layout options.
- The compressor must remain upright and sits on the floor. Allow 24 in [60 cm] clearance in the front of the compressor for electrical lines, water lines, and helium hoses.
- 20 Meter Helium Line Management
- The user interface touchscreen can be placed on any nearby work surface.
- The distance between the System Rack and the Cryostation is limited by the length of lines from the valve motor body. Ensure these lines reach the connections on the top of the cryocooler assembly without excessive curves or bending.

**» NOTE**

Please consider the allowable distance between components, as outlined in the diagram below. The helium hoses between the Cryostation and compressor require a minimum bend radius of 9.0 in (23 cm) with a 4.0 in. (10 cm) straight section at each end.

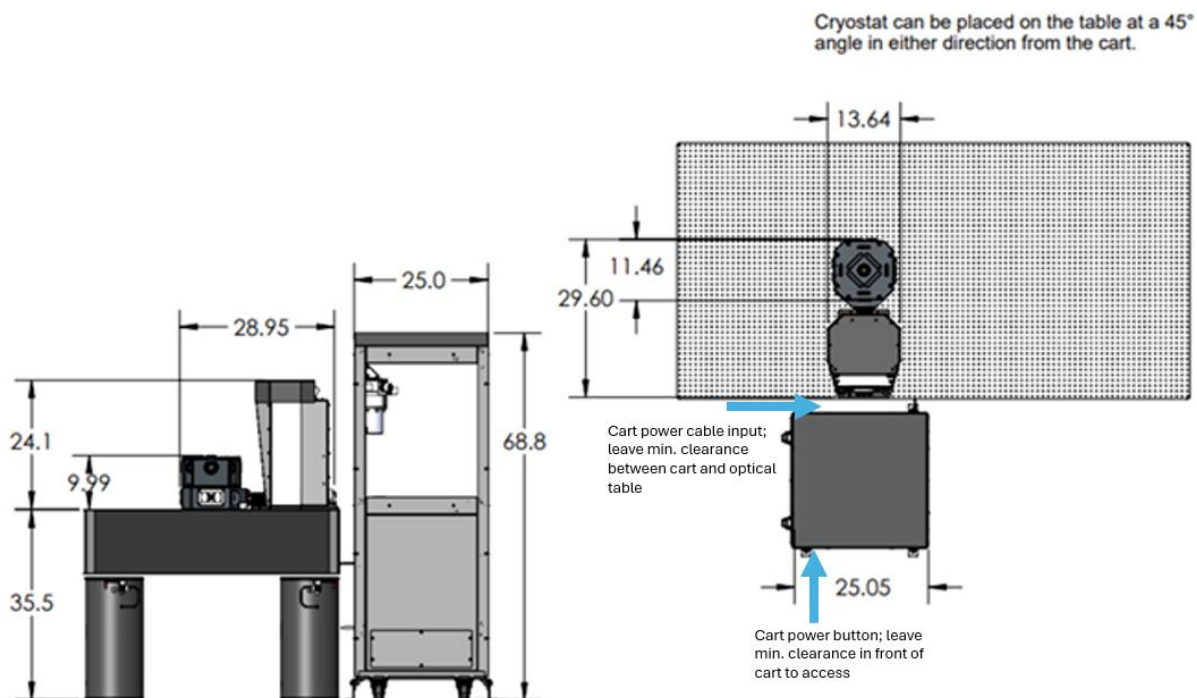

**Figure 3:** Cryostation layout dimensions

# Installation Procedure

1. User Interface
2. LAN
3. Compressor Communication
4. System Control
5. Helium Line
6. Vacuum Hose
7. Nitrogen (N<sub>2</sub> Gas)
8. Chilled Water
9. 3 Phase 200V
10. 120-240V
11. Valve Motor
12. Vacuum Controller
13. Compressor
14. Earthquake support bracket

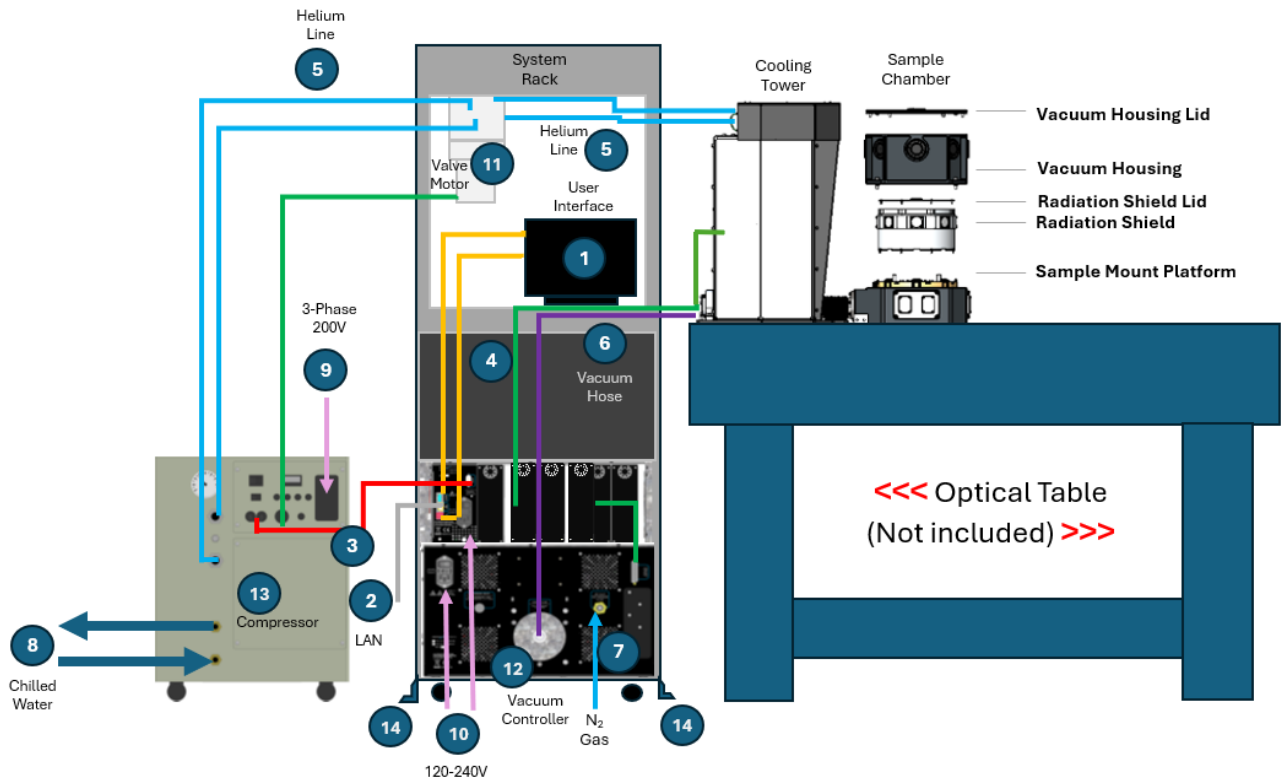

**Figure 4:** Cryostation relative system layout.

## 2.4 Unpacking the Components

### **WARNING**

#### **Use extreme caution when handling the shipment**

A lift or crane is required to move the Cryostation portion of the system. Refer to the appropriate [system user manual](#) for important instructions regarding the safe handling of system components.

### **NOTICE**

#### **Inspect shipment upon receipt**

Before unpacking the system, please note the condition of the boxes, shock watch sensors, and tilt watch sensors. The boxes should be intact and strapped to the pallets. If there is any visible damage or if the sensors have been tripped, contact an authorized service representative immediately and do NOT proceed with unpacking.

#### **Retain equipment packaging for future use**

We recommend saving the original equipment packaging (foam, box, and pallets). The packaging is specially designed to support and stabilize the equipment and will be required if the unit needs to be transported in the future. Some components must be packed upright on a pallet to avoid damage.



*Shock watch*



*Tilt watch*

### 2.4.1 Unpacking the Compressor

1. Locate the pallet.
2. Cut the bands securing the box to the pallet.
3. Carefully remove the box surrounding the unit. Lift directly up and over the surrounding foam.
4. Using two people, lift the compressor off the pallet and gently set it on the floor. Take care not to tilt the compressor. This is so that oil in the compressor does not infiltrate to other internal parts.
5. The compressor has caster wheels for moving. Remove the plastic wrap and roll the unit to its desired location.



*Step 1: Compressor on pallet with straps cut*



*Step 2: Removing compressor box*



*Step 4: Compressor on floor ready to move*

### 2.4.2 Unpacking the Cryostation

1. Locate the crate.
2. Open the crate latches to remove the top lid.



3. Remove cross foam pieces and accessories from the crate.



4. Remove securing straps from the Cryostation.



5. CAUTION: The Cryostation is very heavy and cannot be lifted by hand. A facility "lift" or crane is required to lift the Cryostation out of the crate and to move it. The Cryostation

needs to be lifted onto the optical table prior to the Service Team arriving on-site for system installation. Attach the Cryostation to the lift or crane by using the three (3) provided lift points (M8 x 1.25 thread, 13mm long eyebolts) on the top of the Cryostation, circled in red below. Consult your Facilities department for assistance in operating the lift or crane, if necessary.

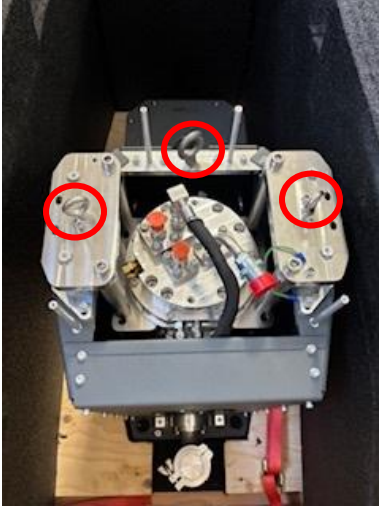

An example of a hook locked in one of the lifting eyebolts is shown in the image below. Ensure eyebolts are hooked securely and evenly before beginning to hoist the Cryostation out of the shipping crate.



6. Using the lift or crane, remove the Cryostation from the crate.
7. Slowly lower the Cryostation onto the optical table. Disconnect the lift from the Cryostation lift points.
8. Carefully remove the plastic wrap around the main body and sample chamber. Leave the window covers in place.

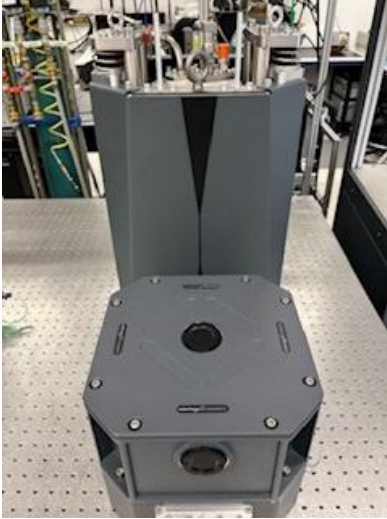

9. Gently slide the unit to the desired location on the optical table.

**» NOTE**

It is highly recommended to use all three lifting point eyebolts when moving the Cryostation. Failure to use all three lifting points may result in damage to your Cryostation.

### 2.4.3 Unpacking the System Rack

Locate the System Rack crate.

1. Remove door ramp latches.



2. Carefully lower the ramp from its upright position. CAUTION: The ramp is heavy; it is recommended to have two people lower it.

## Installation Procedure

---



3. Remove foam and securing block from the crate.



4. Slowly roll the rack down the ramp. Have one person on each side of the rack to keep it steady and prevent tipping.



5. Move the rack to the desired location.

 **WARNING**

**Use extreme caution when unloading the shipment**

A lift or crane is required to move the Cryostation portion of the system. The system rack poses a tipping risk, and it is recommended to have two (2) people unpack and move the rack.

## 2.5 Installing the Cryostation

### 2.5.1 Mounting the Cryostation to the Optical Table

The Cryostation can be mounted at either 45° or 90° to the hole pattern in an imperial or metric optical table. When aligning the system, make sure you can still reach and access the sample chamber and that the baseplate of the Cryostation is within 9 inches of the valve motor located on the system rack.

1. Adjust the cryostat so the mounting holes around the sample chamber and baseplate are directly aligned with holes in the optical table.

The baseplate contains four additional mounting locations, two on the front of the plate near the sample chamber and two at the back of the unit. These locations each have a slotted disk for fine adjustment.

2. Turn the slotted disks at each remaining baseplate location until a table hole is aligned with the slot.
3. Starting at the front of the system, insert a provided short hex screw in each mounting location. Start by loosely starting each screw, turning just enough to hold the screw in place. Minor positioning adjustments may still be required.

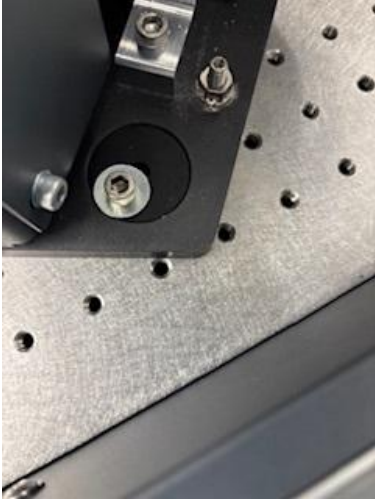

4. After placing a screw at each location, tighten all screws securely, moving front to back.

The sample chamber has 8 mounting locations. It is recommended to utilize at minimum 4 of these locations (one in each corner) for optimal vibration performance. Additional hardware is required if all 8 locations are to be used.

5. Using the provided long hex screws, insert into one of the four corner mounting locations and tighten down. Repeat until all 4 corners of the sample chamber are secured.

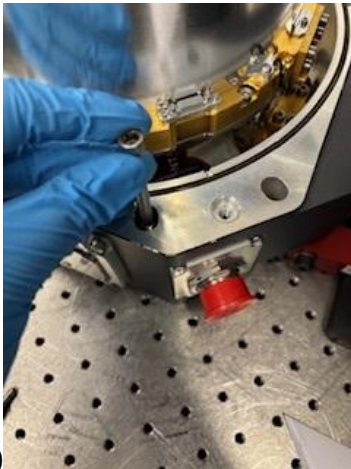

On some models, the operational cable may be shipped disconnected:

6. Locate the cable coming out of the front of the Cryostation tower (next to the black vertical cryocooler cylinder).
7. Connect the cable to the lower connector on the base side panel of the sample chamber at the location labeled: OPERATIONAL



2.5.2 Connecting System Cables and Power

**NOTICE**

**Only use cables and hoses provided or approved by the manufacturer**  
 Only use the cables and hoses in the manner described below.

1. User Interface
2. LAN
3. Compressor Communication
4. System Control
5. Helium Line
6. Vacuum Hose
7. Nitrogen (N2 Gas)
8. Chilled Water
9. 3 Phase 200V
10. 120-240V
11. Valve Motor
12. Vacuum Controller
13. Compressor
14. Earthquake support bracket

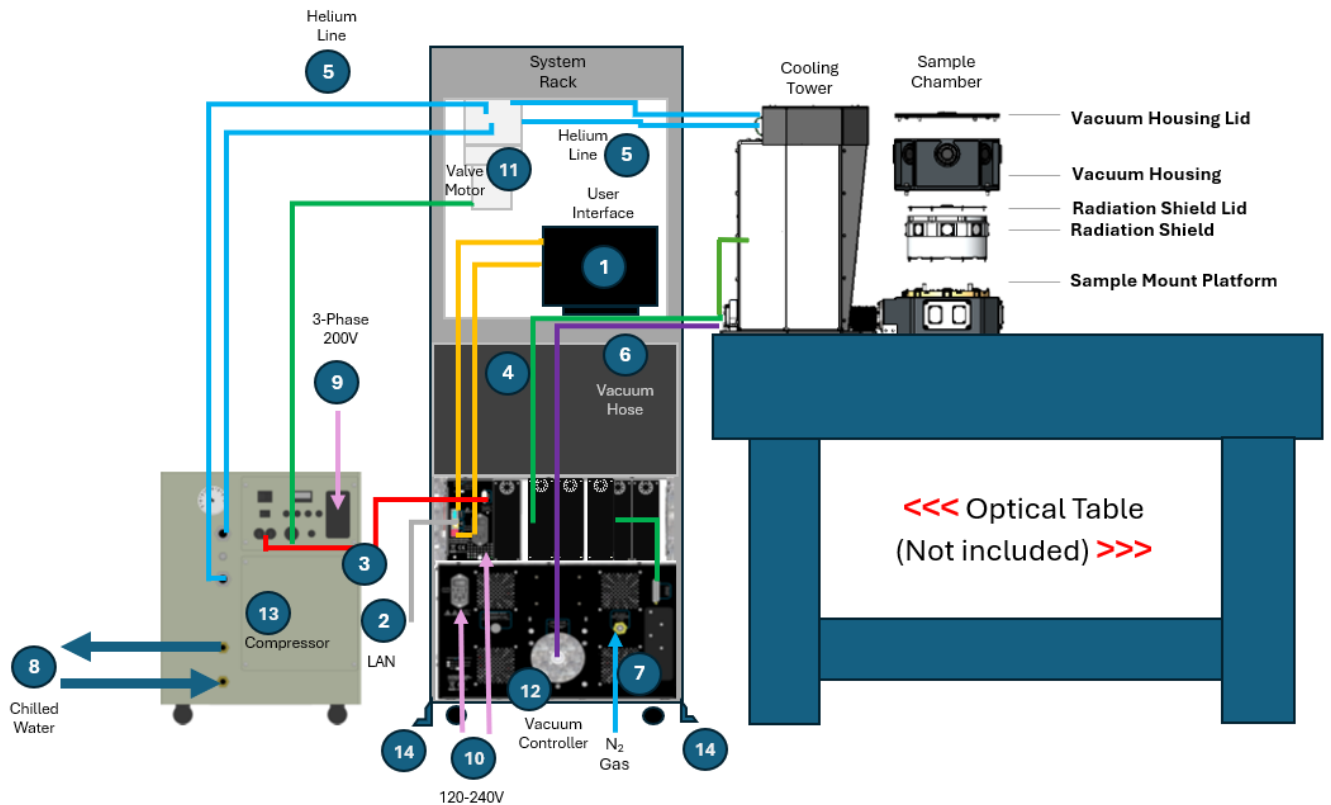

**Figure 5\*:** Cryostation interconnect diagram

\*Compressor model shown here is representative, the product you receive may be cosmetically different.

Note that some connections within the System Rack will be shipped from the factory already connected.

**Chilled Water Connections:** █

Refer to the appropriate Sumitomo compressor Technical Manual for detailed instructions on connecting the chilled water supply and return hoses to your chilled water source.

Compressor Type	Document Title	Original Manufacturer
Water-cooled	<a href="#">F-70 Helium Compressor</a>	Sumitomo

1. Remove any plastic covers from the connector locations on the back of the compressor, the Cryostation, the system control unit, and the vacuum control unit.
2. Connect chilled water lines per the manufacturer's instructions.



Note that users are required to supply both supply and return lines from the facility water connections to the compressor.

**Helium Hoses:** █

**Verify Hose Fittings- General Best Practices**

Improper attachment or missing O-rings on the helium hose fittings can cause a loss in helium pressure and hinder the cooling performance. To inspect fittings on the back of the compressor and cryostat:

- Ensure the fittings are straight.

## Installation Procedure

---

- Ensure there is a **single** O-ring at each end of the hose and at each connection point. The O-rings tend to dislodge from the hose and stay on the fitting (or vice versa).
  - If this happens, the errant O-ring must be carefully removed and replaced in the correct location before reconnecting, otherwise it will not seat properly.



*Hose with extra O-ring*



*Extra O-ring removed*



*Left: Fitting missing O-ring  
Right: proper O-ring fitment*

Note that your helium hoses may be longer or shorter than pictured. Hoses and fittings may be cosmetically different.

Helium hoses should first be tightened by hand. Use a crescent wrench to continue to tighten the main line fittings, stopping as soon as force is required. Do not overtighten.

3. Locate the helium hose labeled **SUPPLY**. Connect one end to the **SUPPLY** location on the front of the compressor. Connect the other end to the **SUPPLY** location on the valve motor body on the System Rack. Supply is banded in yellow on both ends of the hose.
4. Locate the helium hose labeled **RETURN**. Connect one end to the **RETURN** location on the front of the compressor. Connect the other end to the **RETURN** location on the valve motor body on the System Rack. Return is banded in green on both ends of the hose.

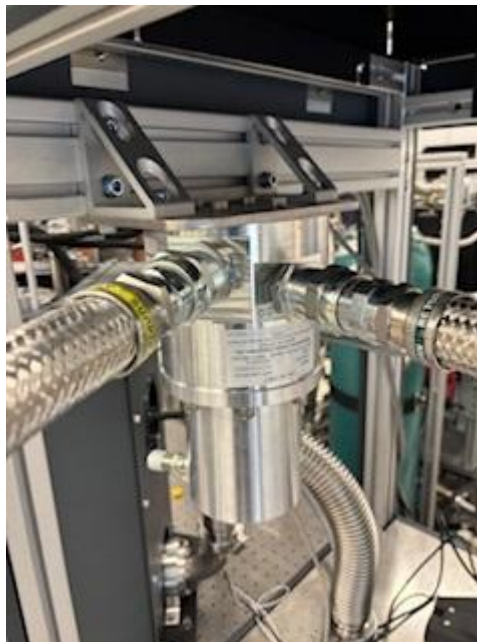

5. Connect the main helium hose from the valve motor body to the top of the cryocooler assembly. The connection on the Cryocooler and the top of the hose fitting are labeled "Tank".



6. Connect the 2<sup>nd</sup> line from the valve motor body to the cryocooler assembly. Both the hose fitting and the connection on the cryocooler assembly are labeled "2<sup>nd</sup>". The 2<sup>nd</sup> line is easier to install before the 1<sup>st</sup> line is installed.



7. Connect the 1st line from the valve motor body to the cryocooler assembly. Both the hose fitting and the connection on the cryocooler assembly are labeled "1<sup>st</sup>".



**NOTICE****Check cable connections**

- Be sure to connect the supply to supply and return to return. Do NOT switch the supply and return hoses, as the return hose may have internal contamination from extended use.
- Be sure to connect the first, second, and tank hoses from the valve motor to the top of the pulse tube assembly in the correct places. Failure to do so may damage the system.
- Before connecting, ensure there is a single O-ring at each connection point and hose end.
- Keep the fittings straight to avoid any loss of helium as the hose is attached.
- Damage may result if the helium supply and return lines do not have room to expand and contract. Ensure the tubing runs straight from the back of the unit and makes loose gentle bends between connections. The minimum bend radius is 9 inches (23 cm) for 30-foot (9m) hoses.
- Do not let the helium hoses contact or rest on the optical table, as this can introduce vibrations.
- Cabling from the System Rack can be routed through the hole in the top of the cart.

**Locking Down the System Rack****Locking the Rack**

8. The System Rack has locking feet next to each caster wheel. Lock these in place by unscrewing the bottom nut nearest the foot. Once the foot is level on the floor, tighten the upper nut to lock the foot into place. Repeat this process for each foot, ensuring the System Rack is level after each adjustment.



### Installing Earthquake Supports on the System Rack

---

The system rack cart comes with 4 earthquake support brackets that anchor the rack to the floor. The support brackets are anchored to the floor with 9/16" bolts (hardware included). 4 holes will need to be drilled into the facility floor to anchor the support brackets. Install supports once all hoses are installed and the System Cart feet are locked into place.

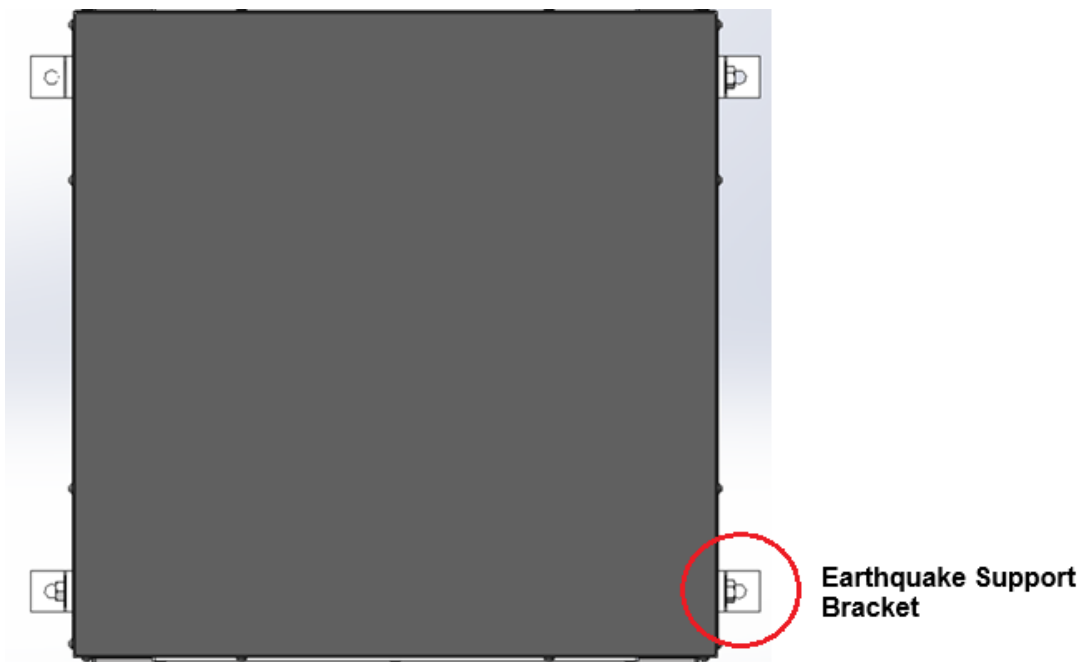

**Figure 1:** Top view of system rack with earthquake supports shown

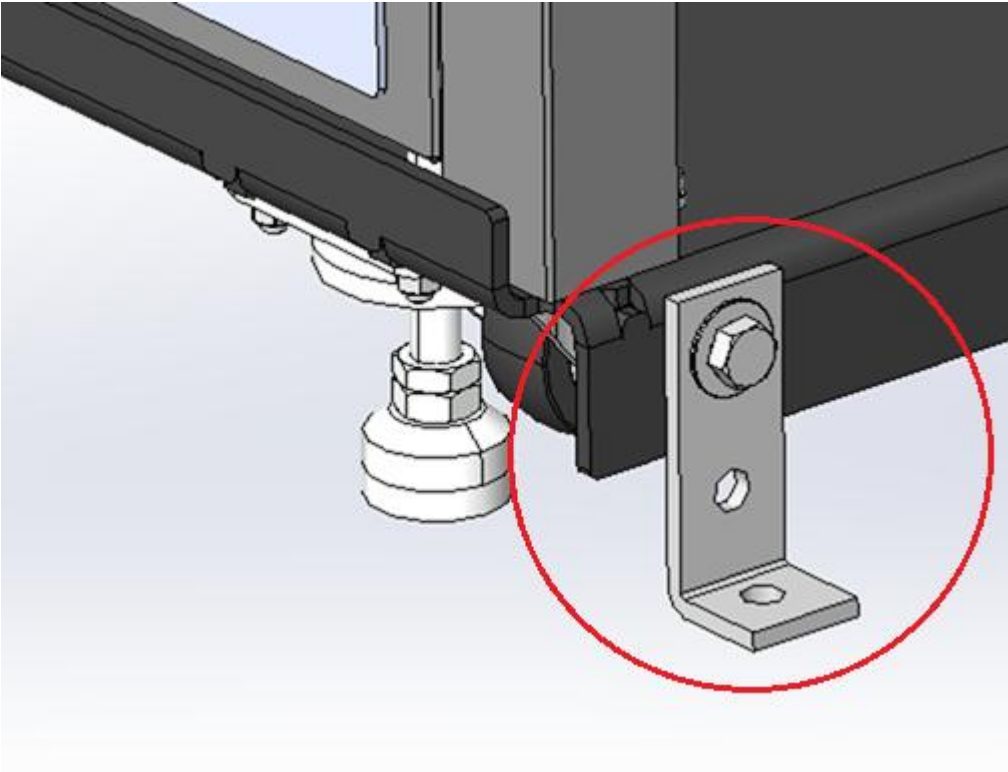

**Figure 2:** Earthquake support bracket and adjustable rack foot shown (only one corner shown)

#### Interconnect Cables: \_\_\_\_\_

9. Locate the circular socket to DSUB connector cable. Connect the DSUB end to the back of the System Control Unit . Connect the socket end to the OPERATIONAL location on the side panel of the Cryostation. This cable is labeled "Chamber" on the System Control Unit end.

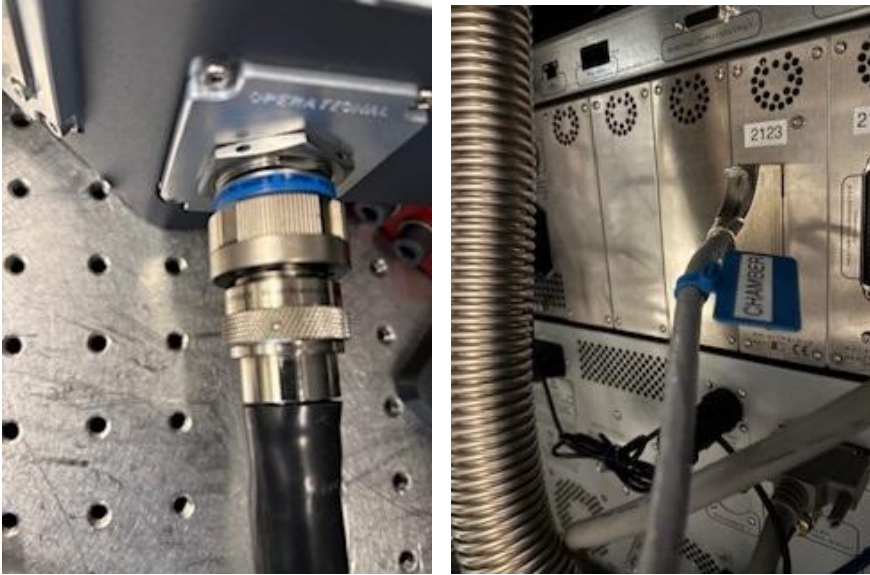

10. Connect the cable from the valve motor **POWER** connector to the front of the compressor.



11. Connect the cable to the back of the Cryostation. Connect the DSUB cable to the back of the System Control Unit. This cable is labeled "Cooler".

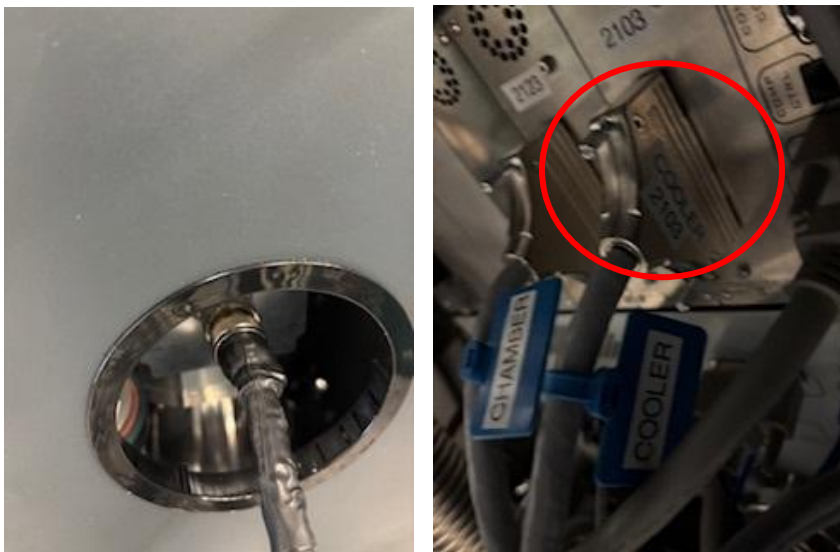

**Compressor Communication:** —————

12. Locate the DSUB9 F-F series cable. Connect one end to the `SERIAL` location on the front of the compressor. Connect the other end to the `CAN` location on the back of the system control unit. Tighten both connections with the thumbscrews to secure.



**Vacuum Hose:** —————

13. For Standard Systems: Locate the vacuum hose. Connect one end to the `VACUUM LINE` at the back of the Cryostation. Connect the other end to the back of the Vacuum Control Unit. Hose can be routed through either of the top holes in the System Rack.



14. For Turbo Systems: Locate the vacuum hose. Connect one end to the `VACUUM LINE` location on the back of the Cryostation. Connect the other end to the `VACUUM LINE` location on the System Rack.



**NOTICE**

**Check cable connections**

- Do NOT over-tighten the vacuum hose, as this can spin the fitting and cause a vacuum leak.
- Make sure the vacuum tube fitting has a single O-ring in it. The O-rings occasionally come loose and fall out.

**User Interface:** —————

15. Locate the USB and HDMI cables. Connect these cables from the back of the system control unit to the user interface touchscreen display. Optional ethernet connection is in the same location on the back panel of the system control unit.



### Nitrogen (optional): —————

To keep the sample space clean, a dry clean nitrogen connection is highly recommended\*, especially in humid climates. Nitrogen will help rid the system of moisture and decrease the initial pump downtime. Nitrogen is required for turbo-equipped systems.

16. Connect a ¼ in (6mm) tube to your nitrogen source (this tubing is not supplied).
17. Start the nitrogen supply at a low flow rate.
18. Verify that the nitrogen is flowing through the tube and does not contain any water vapor. Allow some nitrogen to flow through the tube to remove impurities.
19. Connect this tube to the N<sub>2</sub> INLET fitting on the back of the vacuum control unit by pressing in.
20. Set the nitrogen pressure to 10-100 psi MAX for standard vacuum control module. For the turbo vacuum control module, 50-100 psi MAX is required to operate the pneumatic turbo case valve.

To disconnect the tubing, push the green circle on the fitting inwards and pull the tubing out.



For Turbo systems only: Connect nitrogen to the port circled in red for proper operation of the turbo.

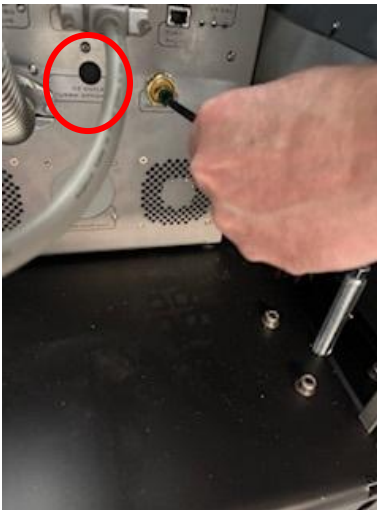

\*Your Vacuum Control Unit back panel may look cosmetically different.

**» NOTE**

This system uses nitrogen during a VENT, COOLDOWN, or PULL VACUUM operation if a “dry nitrogen purge” is enabled. Nitrogen is required for turbo-equipped systems.

**System Power:** —————

Be sure to connect all other cables and hoses before connecting system power.

21. Locate the C13 main System Rack power cord.
22. Connect the main power cord to the C14 inlet located on the rear of the enclosure.



23. Connect the power plug to the appropriate 100 – 240 VAC wall outlet power source.
24. System Control and Vacuum Control power cables should be plugged into the power strip on the System Rack.

### Compressor Power (3 Phase): —————

The F-70LP compressor runs on 200VAC $\pm$ 10% 3-phase power. The F-70HP compressor runs on 460-480VAC $\pm$ 10% 3-phase power at 60 Hz and on 380-415VAC $\pm$ 10% 3-phase power at 50 Hz. This needs to be installed in the lab prior to installation by an electrician or other certified professional. A 16-foot unterminated power cable is supplied. For reference, the images below show a plug and cord example that was used during factory testing. The compressor can also be hardwired, if desired (refer to Sumitomo [F- 70 manual](#) for hardwiring instructions). If using a cable, ensure that it is rated for the amperage of the compressor and for 3-phase power. The cable is connected to the compressor in the following steps.



**⚠ WARNING**

**Use extreme caution with the compressor power input**

Ensure the compressor is off and unplugged before doing any maintenance or service to the power input on the compressor.

25. Remove the power input cover screws using a Phillips head screwdriver.





Note: There is a second screw on the opposite side not pictured.

26. Install the wiring by inserting the exposed/stripped end of the wire into the receptacle. Green is the ground wire in this image. Tighten with a flathead screw drive until clamp screws are snug.



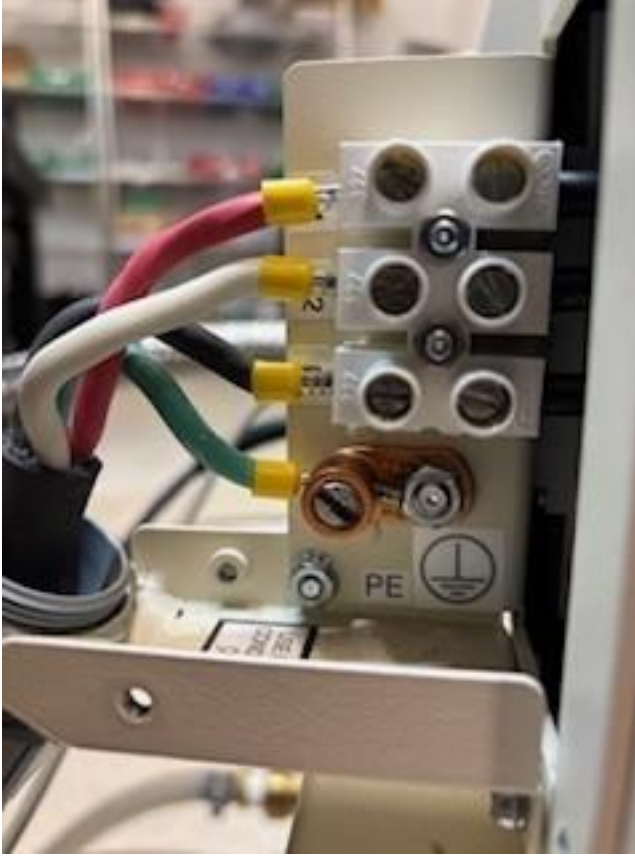

27. Turn the compressor power switch to ON.



28. Power on the System Control Unit.

29. If there is a Phase Power warning (see image below) or the cryocooler is displayed as disconnected, wires need to be swapped around at the compressor. Do this by first turning the compressor off and the Control Unit off. Then unplug the compressor from power. Swap 2 wires and turn the system on again. Repeat this process until the startup warning on the User Interface is gone on system startup.

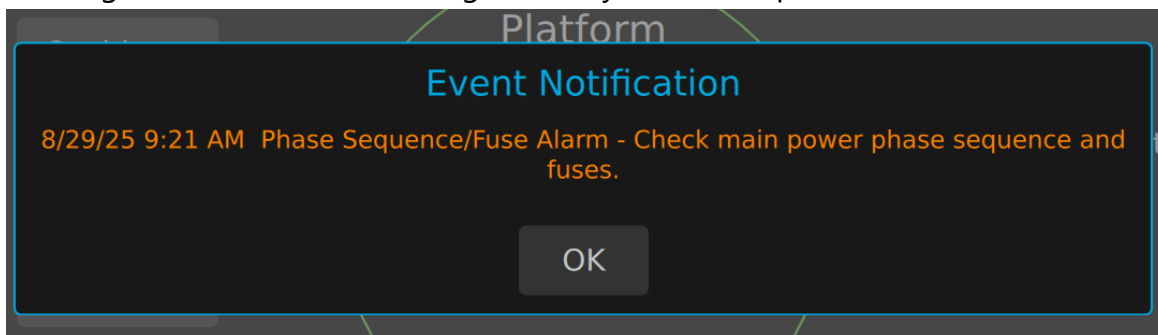

» **NOTE**

The helium hoses should never be bundled or strapped down in any location.

### 2.5.3 Removing the Shipping Supports

Once the Cryostation is ready to run its first cooldown, the shipping supports can be removed. These should be removed for optimal performance. Removing or reinstalling the shipping supports requires removing the top cover of the cooling tower assembly.

1. Locate the red aluminum blocks on either side of the top of the Cryostation.
2. Remove the eye bolts and screws holding the blocks to remove them.
3. Reinstall the top cover.

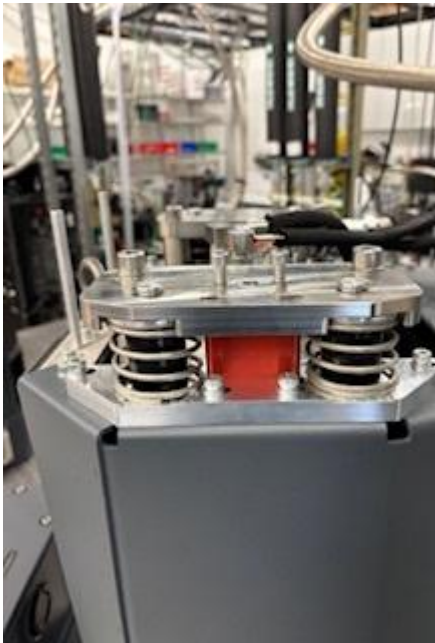

*Shipping support (only one shown)*



*Shipping support and hardware removed*



*Reinstalling the top cover*

The Vacuum Control Unit also has shipping brackets that need to be removed prior to system use.

1. Remove the cover panel on the side of the cart.



2. Remove the 2 bolts holding the first bracket with an M4 Allen key. Remove the final 2 bolts using an M4 Allen key. The final bracket will stay in place once the bolts are removed. Retain the bracket and bolts should you need to ship the unit in the future.



**NOTICE**

Keep the shipping supports and screws. These should be reattached and locked in place any time the Cryostation needs to be moved in the future.

## 2.6 Initializing the Cryostation

You are now ready to power on your system!

Please refer to the "System Usage & Operation" section of the appropriate User Manual for your product model to find detailed instructions on how to do this.

All manuals can be found on the Montana Instruments [product documentation page](#).