

## PRESSPOWER 3 BLOCK DIAGRAM

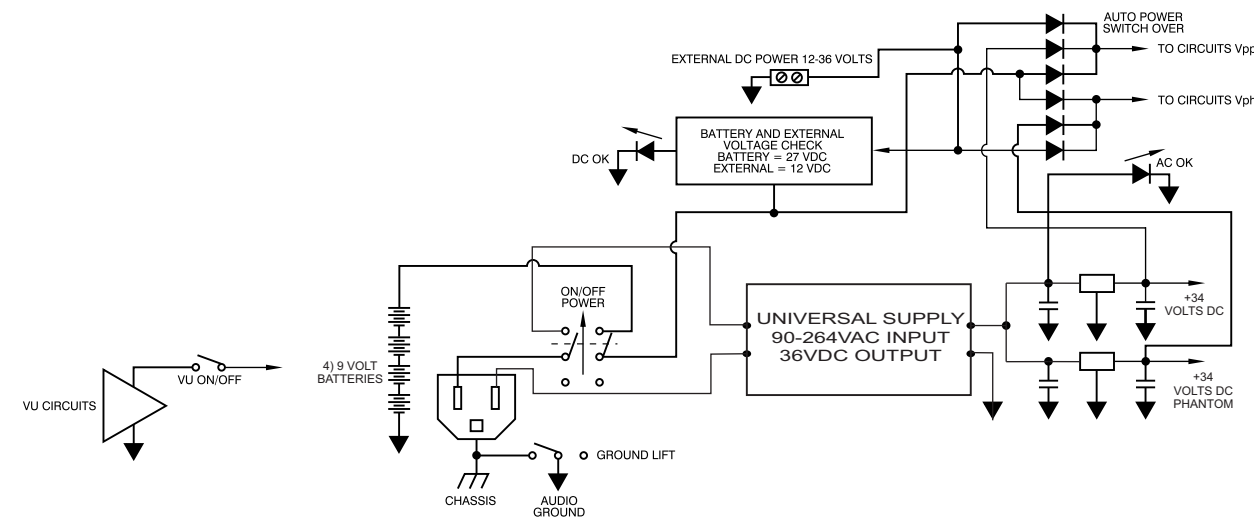
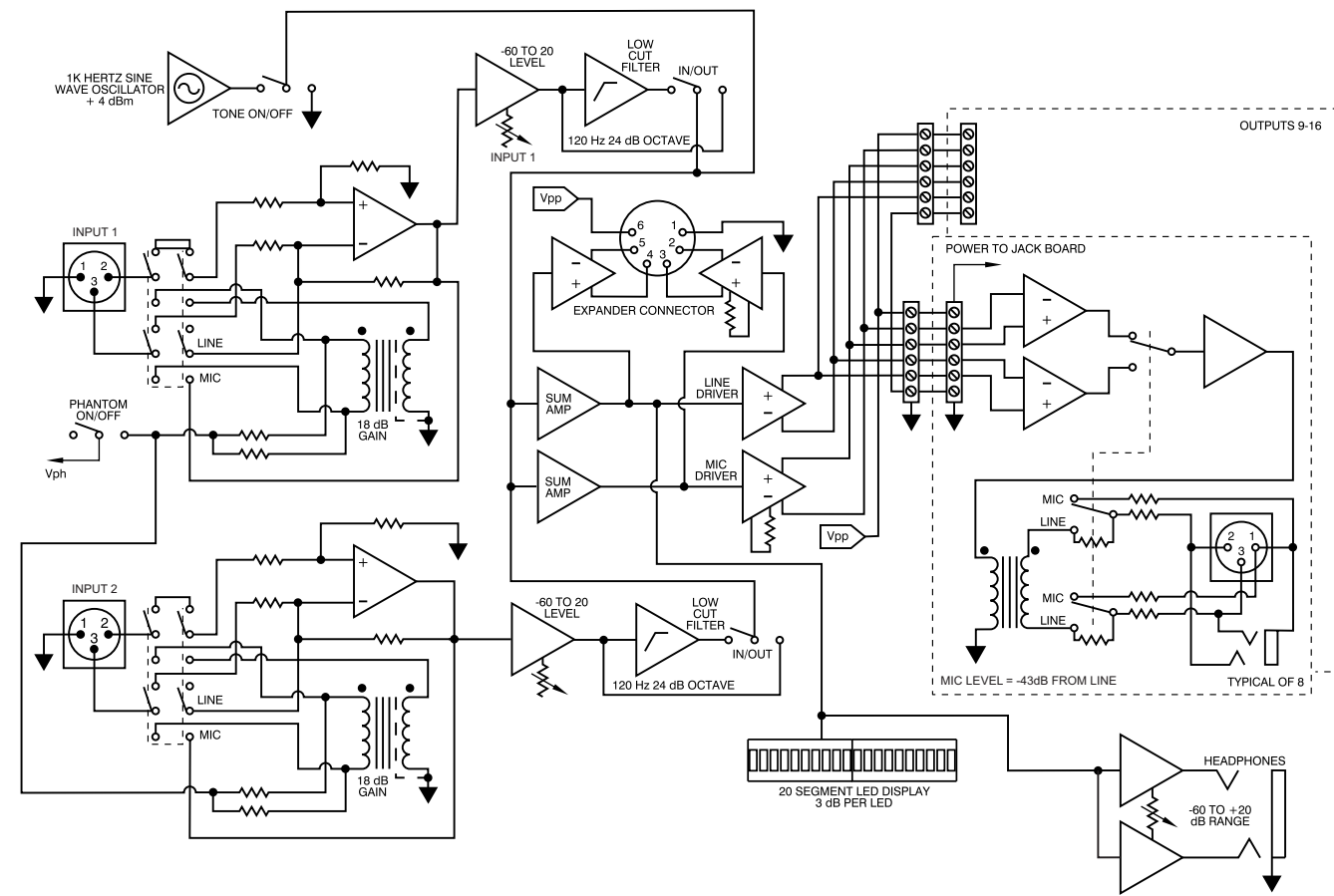

## SPECIFICATIONS

### Frequency Response

-5 dBm 20 Hz to -2 dBm at 16 kHz

### Input Impedance

Mic mode  
Line mode

1.5 k ohms  
200 k ohms

### Maximum Input Level

Mic mode  
Line mode

-5 dBm mic mode  
+23 dBm line mode

### Output Impedance

Mic mode  
Line mode

150 ohms  
150 ohms

### Maximum Output Level

Mic mode  
Line mode

-5 dBm into 2 k ohms  
+23 dBm into 2 k ohms

### T.H.D.

.075% at 1 kHz at unity gain mic mode

### Phase Shift

-6 degrees at 1 kHz unity gain

### Intermodulation Distortion

.04% at unity gain mic mode

### Range of Level Pot

-60 to +20 dBm

### CMR of Mic Input at 60 Hz

>75 dBm at 60 Hz

### CMR of Line Input at 60 Hz

>50 dBm

### Range of Headphone Volume Control

-60 to +20 dBm

### Isolation between Mic Outputs

>95 dBm

### Isolation between Line Outputs

>60 dBm

### Power draw

AC mode

31 watts maximum

Battery mode  
(All measurements using Mic input driving all outputs)

mA DC    battery life

On with no Led Meter no Headphones    40    15 hours  
On with Led Meter in Dot mode no Headphones    73    9 hours  
On with no Led Meter and 30 ohm Headphones    60    10 hours  
On with Led Meter in Dot mode and 30 ohm Headphones    94    5 hours

### Size (in Case)

20 X 9.5 X 8.5 inches

### Weight

Rack Unit with no Case    12 lbs  
Rack Unit with Case    17 lbs  
Shipping Weight Unit in Case    20 lbs

SPECIFICATIONS SUBJECT TO CHANGE WITHOUT NOTICE

# U.S. Audio whirlwind

99 Ling Road  
Rochester, NY 14612  
Phone 585 663-8820 . Fax 585 865-8930  
Email: Sales@whirlwindusa.com  
http://whirlwindusa.com



## PressPower 3

U.S. Audio  
whirlwind

### Introduction

Thank you for selecting the U.S. Audio Presspower 2 audio press feed distribution box. The Presspower 2 delivers broadcast quality audio from 16 mic or line level transformer isolated outputs. Features include a 20 segment led VU display for quick visual level setting, a headphone monitoring section, a tone oscillator for level calibration and a fail safe AC/DC battery power supply for uninterrupted operation and portable use. There are two balanced mic or line level inputs and an optional expander unit, the Presspower 2 Expander is available with 16 additional mic or line level outputs. The Presspower 2 is a four rack space unit and comes with a padded nylon carrying case for portability.

### Unpacking

U.S. Audio has made every effort to ensure that your equipment is received in the same perfect condition it was in when it left the factory. Please inspect your product for any signs of damage during shipping and report them to your dealer so that a claim can be presented to the shipper. We recommend that you save your packaging material for use in the unlikely event that you need to return your equipment for service.

### Input control knob conversion

In order to deter users from making unauthorized adjustments to the input gain during use, the input gain controls on the PRESSPOWER 2 have been changed from knob adjustment to adjustment by screwdriver, coin, pocketknife etc.

If knob actuation is desired, remove the black bushings and install the included knobs as follows. Carefully pry the edge of the bushings away from the front panel and depress the plastic fingers that hold them in place. The fingers are located behind the printed areas on the face of the bushing. Rotate the control fully counterclockwise, align the knob's pointer with the scale and push it onto the shaft. If repositioning is required, the knob insert must be removed separately by grabbing the rectangular top with pliers and pulling it off. Reinstall the insert into the knob by aligning the ridge on the insert with the groove inside the knob behind the pointer.

**whirlwind**  
whirlwindusa.com

## THEORY OF OPERATION

The Presspower 2 has two balanced inputs, each switch selectable for mic or line level signals. In mic mode, a mumetal shielded transformer provides low distortion, impedance gain of 18 dB and high common mode rejection. Faraday shields in the transformer and RF beads used at the input XLR offer broadband RF rejection. Capacitors are also used for AM band rejection. A phantom power switch applies DC power to both mic inputs simultaneously. The value of the phantom voltage is dependent upon the type of power source energizing the Presspower 2. In line input mode, the mic preamplifier transformer is bypassed and an active balanced input is employed. The line input is capable of receiving signals up to +35 dBm.

From each input circuit the signal is applied to a potentiometer circuit that has an audio like taper, allowing fine tuning of the level from the 9 o'clock through the 3 o'clock range. The 12 o'clock position yields unity gain in either mic or line mode with approximately 6 dB of gain adjustment 90 degrees in either direction. Below the 9 o'clock position, the potentiometer attenuates the signal in larger increments and fully counter clockwise the attenuation is 65 dBm which will mute the input. Above the 3 o'clock position, gain increases rapidly up to +20 dBm with the control turned fully clockwise. After the gain circuits, the signal passes through a switchable low cut filter. The filter has a 24 dBm per octave slope, down 3 dBm at 120 Hertz. This filter is recommended for mic use as it eliminates low frequency handling and wind noise.

The inputs signals are then summed and applied to two separate output busses, one for mic level outputs and one with an additional 20 dB of gain for line level outputs. The line level feed also is applied to the headphone monitor section and the LED level display. The mic and line level busses are routed to the active jack boards via a balanced cable harness with plug terminations. The Expander receptacle is also connected at this point in the circuit.

At each of the 16 outputs of the Presspower 2 or its expander module, the mic/line switch selects the mic level or the line level signal buss and delivers it to a buffer circuit which drives a Whirlwind TRSP-1 balancing transformer. In mic output mode a resistive H pad is switched into the circuit to attenuate the signal by 20 dB. The H pad also provides a ground reference relative to pins 2 and 3 of the XLR, but not connected to any other ground, which minimizes possible ground loop problems. In line output mode, pin 1 of the output XLR is left floating. A 3.5 mm mono jack is provided for each output, which is paralleled to the XLR.

The tone oscillator applies a 1 kHz sine wave to all outputs for level calibration during setup. The tone level is +4 dBm or 0 VU in line mode and -43 dBm in mic mode.

The headphone driver circuitry provides monitoring of the Presspower 2 output. Each earpiece is isolated by resistors ensuring that Tip/Sleeve headphone connectors (which short the ring) will not short out the entire signal. The headphone amps are capable of driving 0 dB into 30 ohm headphones, which can significantly reduce battery life. When only using battery power, turn the headphone level full counter clockwise or unplug the headphones to conserve the batteries. The taper of this level control is similar to the control on the inputs.

A 20 segment LED level meter with a 3 dB per segment resolution provides a wide range of display with 1 dB accuracy. Two switches are provided to help maximize battery life when using 9 volt battery power. Under battery power only select dot mode to calibrate levels and use the meter on/off switch to turn the LED display off when not required. Use the bar mode when the Presspower 2 is under AC power.

The Presspower 2 has a versatile unipolar power supply allowing the unit to operate from 120 VAC 60 Hz, 230 VAC 50 Hz, 4 internal 9 volt batteries or any battery or regulated DC source from 12 to 36 volts. Any combination of the three types of power can be used simultaneously. The unit will automatically select the highest voltage, providing fail safe backup and making it easier to power in remote applications. Under AC power a toroid power transformer is used internally for superior performance and a voltage switch on the back panel selects 120 or 230 VAC. Nine volt batteries are mounted on the front panel in convenient quick change holders. An external DC input (screw type) on the back panel will accept 12 to 36 volts DC, from either batteries or a regulated source. This allows use with camera belt packs, car batteries, etc. At 12 volts DC with a -40 dB mic input and 40 dB of gain, the Presspower 2 will output up to +8 dBm in line mode.

The power on/off switch turns both the AC and the internal 9 volt battery power on and off. The external DC input on the back panel is unswitched. The AC LED illuminates when AC power is present and is switched on. The DC power LED functions as a battery check LED for the 9 volt batteries and illuminates when 12 VDC or more is present at the external DC power input. With no external DC, the DC LED will light when the batteries are good and the power switch is on. When the total series voltage drops below 28 volts the DC LED goes out and all four batteries should be changed.

## CONTROLS AND FUNCTIONS

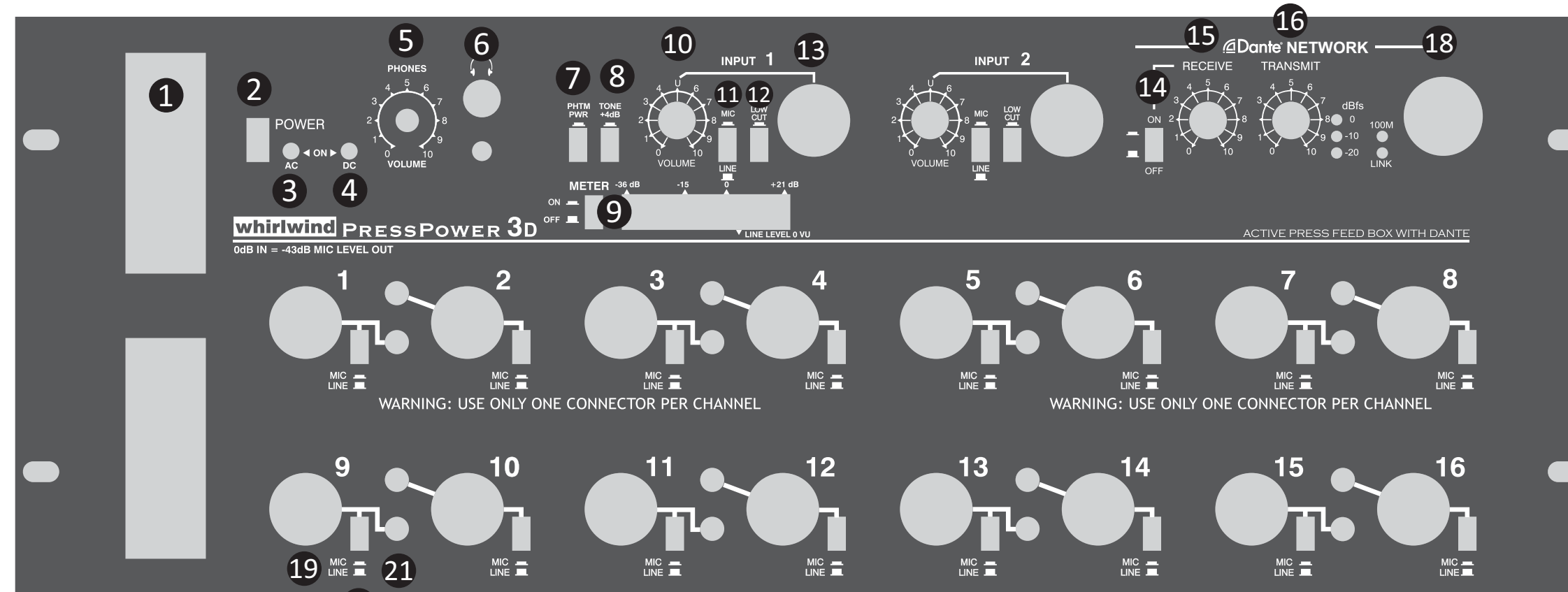

## FRONT PANEL

- BATTERY HOLDERS** contain the four 9 volt batteries in drawer style holders. Alkaline or lithium batteries are recommended.
- POWER SWITCH** turns both the AC and internal 9 volt battery power on and off. It does not effect the rear panel DC input.
- AC POWER LED** illuminates with AC power present and switched on.
- DC POWER LED** illuminates when the 9 volt batteries are good and the power switch is on, or when 12 volts DC (minimum) is present at the external DC power input connector.
- HEADPHONE LEVEL CONTROL** adjusts the volume at the headphone jack through a range of -60 to +20 dBm. Under battery power, turn the level off when not using the phones to prolong battery life.
- HEADPHONE JACK** is 1/4" TRS for connecting stereo headphones but will also work with mono earpieces.
- METER ON/OFF SWITCH** turns the LED display on and off when not required which will conserve the 9 volt batteries.
- METER BAR/DOT MODE SWITCH** selects bar or dot display mode so that either all LEDs below the actual level are on, or a single LED is on at the actual level. Use the dot mode with 9 volt battery power.
- 20 SEGMENT LED METER** with 3 dB per segment resolution provides a wide range display with 1 dB accuracy.
- PHANTOM POWER SWITCH** applies phantom power to both mic inputs. Voltage is 48 VDC (AC Operation), 36 VDC (9 volt internal battery operation) or the value of the external DC power supply.
- TONE SWITCH** applies a 1 kHz sine wave to all outputs for level calibration during setup. The tone level is +4 dBm or 0 VU in line mode and -43 dBm in mic mode.
- INPUT LEVEL CONTROL** varies the amount of signal delivered to the outputs. The 12 o'clock (U) position yields unity gain in either mic or line mode with approximately 6 dB of gain adjustment 90 degrees in either direction. Large increments of adjustment occur at both ends of pot rotation with a total range of -60 to +20 dBm.
- LOW CUT SWITCH** activates a filter with a 24 dBm per octave slope, down 3 dBm at 120 Hertz. This filter is recommended for mic use as it eliminates low frequency handling and wind noise.
- INPUT MIC/LINE SWITCH** selects the appropriate circuit for the applied signal. The mic circuit is transformer balanced with a maximum input level of -5 dBm. The line circuit is actively balanced with a maximum input level of +35 dBm.
- INPUT XLR** female connector is RF filtered with pin 2 positive.
- OUTPUT 3.5 MM JACK** is wired positive signal to tip and negative to ring. Do not use this and the XLR output simultaneously.
- OUTPUT XLR** male connectors are transformer isolated and ground lifted from each other, pin 2 is positive.
- OUTPUT MIC/LINE SWITCH** selects the signal level at each output. Mic level is 43 dBm below line level.

# whirlwind