

COSASCO®



User Manual

BT Wireless Suite

Transfer Unit, Microcor® ER
Datalogger, ER Probe Reader, LPR
Probe Reader, Legacy Converter,
ER Datalogger, LPR Datalogger



Disclaimer

MICROCOR®, COSASCO®, CORROSOMETER®, CORRATER® and ULTRACORR® are registered trademarks of Rohrback Cosasco Systems, Inc. Windows® is a trademark of Microsoft Corporation.

No part of this manual may be reproduced or transmitted in any form or by any means, electronic or mechanical, including photocopying and recording, for any purpose, without the express written permission of Rohrback Cosasco Systems, Inc.

Table of Contents

Chapter 1 Introduction	1
Transfer Unit	1
Microcor ER Datalogger	1
ER Probe Reader	1
LPR Probe Reader	1
Legacy Converter	1
ER Datalogger	2
LPR Datalogger	2
Chapter 2 Specifications	3
Transfer Unit (TU-500)	3
Microcor ER Datalogger (M-200)	4
ER Probe Reader (ER-100)	5
LPR Probe Reader (LPR-100)	6
Legacy Converter (LC-500)	7
ER Datalogger (ER-200)	8
LPR Datalogger (LPR-200)	9
Chapter 3 Basics of the BT Wireless Suite	10
Transfer Unit	10
Battery Installation	10
Standby Screens	11
Scanning for Devices	11
Device List	12
Display Configured IDs	12
Setting Units	13
Setting Time	13
Clearing Memory	14
Microcor ER Datalogger	15
Power Module Installation	15
Mounting the Microcor ER Datalogger	15
Cosasco Mounting Accessories	18
ER Probe Reader and LPR Probe Reader	19
Battery Installation	19
Checking Battery Status	20
Using the ER Probe Reader	21
Using the LPR Probe Reader	22
Turn Off Probe Readers	22
Legacy Converter	23
Battery Installation	23
Checking Battery Status	23
Using the Legacy Converter	24
Turn Off Legacy Converter	24
ER Datalogger and LPR Datalogger	25
Battery Installation	25
Installation	26
Chapter 4 Transfer Unit	29
Microcor ER Datalogger	29

Create an ID for Microcor ER Datalogger	29
Load ID onto Microcor ER Datalogger	30
Download Data from Microcor ER Datalogger	31
Read Microcor ER Datalogger Status	32
Chapter 5 ER Probe Reader	33
Create an ID for ER Probe Reader	33
Take Data Point	35
Download Data Point from Reader	36
Chapter 6 LPR Probe Reader	37
Create an ID for LPR Probe Reader	37
Download Data Point from Reader	39
Chapter 7 Legacy Converter	40
RDC-CO(T)	40
Create an ID for RDC-CO(T)	40
Load Configuration onto RDC-CO(T)	42
Download Data from RDC-CO(T)	43
Read RDC-CO(T) Status	44
RDC CA(T)	45
Create an ID for RDC-CA(T)	45
Load Configuration onto RDC-CA(T)	47
Download Data from RDC-CA(T)	48
Get Status of RDC-CA(T)	49
Microcor Datalogger/ML-9500B	50
Create an ID for a Microcor Device	50
Load ID onto Microcor Datalogger and ML-9500B	51
Download Data from Microcor Datalogger and ML-9500B	52
Read Microcor Datalogger/ML-9500B Status	53
Chapter 8 ER Datalogger	54
Create an ID for ER Datalogger	54
Load Configuration onto ER Datalogger	56
Download Data from ER Datalogger	57
Get Status of ER Datalogger	58
Chapter 9 LPR Datalogger	59
Create an ID for LPR Datalogger	59
Load Configuration onto LR Datalogger	61
Download Data from LPR Datalogger	61
Get Status of LPR Datalogger	62
Chapter 10 Transfer Readings from the Transfer Unit to Cosasco Data	63
BT Wireless Communication Requirements	63
Create a New Group	63
Open a Group	65
Add a Probe Through Cosasco Data	67
Create Nodes for New Probes (Optional)	69
Connect Transfer Unit to PC	71
Configure Probes	73
Configure Individual Probes	73
Configure All Probes	75
Download Data	76
Download Individual Probe Data	76
Download All Probe Data	77

Appendix A Update Device Firmware	79
TU-500 Firmware Update Instructions	79
Troubleshooting	82
ER-100, LPR-100, ER-200, and LPR-200 Firmware Update Instructions	85
Appendix B EC Type Examination Certificates	88
Transfer Unit	88
ER Probe Reader	91
LPR Probe Reader	94
Legacy Converter	96
ER Datalogger	100
LPR Datalogger	104
M-200	108
Appendix C Certificates of Conformity	111
Transfer Unit	111
ER Probe Reader	114
LPR Probe Reader	118
Legacy Converter	121
ER Datalogger	125
LPR Datalogger	129
M-200	133
Appendix D Drawing 726061	136
Appendix E Drawing 726062	137
Appendix F Drawing 702408	138

Chapter 1

Introduction

Transfer Unit

The Transfer Unit (TU-500) handheld instrument is the convenient and hassle-free way to configure and collect data from Microcor Dataloggers, ER Readers, LPR Readers, ER Dataloggers and LPR Dataloggers. The Transfer Unit can be used with Cosasco BT Wireless enabled devices via a BT Wireless link used as a serial cable replacement. The Transfer Unit can also be used with other Cosasco legacy devices with the addition of the Legacy Converter. This portable unit can store readings of up to 255 total devices including up to 99 Microcor and/or a combination of up to 255 ER and LPR IDs. This intrinsically safe handheld device allows an operator to program and collect data from Cosasco devices installed in hazardous locations. Furthermore, this device allows simple and fast data transfer using Cosasco Data software and a Bluetooth Dongle.

Microcor ER Datalogger

The Microcor[®] ER Datalogger (M-200) is based on Cosasco's latest generation of high-resolution Microcor technology. The M-200 operates in conjunction with the high-resolution Microcor probes that Cosasco offers. The Microcor ER Datalogger is an 18 bit high-resolution corrosion measurement device, approximately 256 times higher than previous electrical resistance measurement instruments. This increased resolution greatly improves response to corrosion upsets, and at the same time allows measurements to be made in virtually any environment. The patented technology combines speed of response, similar to linear polarization resistance, with the universal applicability of electrical resistance measurements.

ER Probe Reader

The ER Probe Reader (ER-100) was designed to be used together with the Transfer Unit and to replace the older Checkmate and Checkmate Plus handheld instruments. The ER Probe Reader is able to read all standard Cosasco ER probes and reads both corrosion data and temperature. For convenience, the ER Probe Reader communicates with the Transfer Unit via a BT Wireless link used as a serial cable replacement.

LPR Probe Reader

The LPR Probe Reader (LPR-100) was designed to be used together with the Transfer Unit to replace the Mate II and Aquamate handheld instruments. The LPR Probe Reader reads all standard Cosasco LPR probes and can read both corrosion rate and temperature. It communicates with the Transfer Unit via a BT Wireless link used as a serial cable replacement.

Legacy Converter

The Legacy Converter (LC-500) is an RS232 to BT Wireless serial converter that allows the Transfer Unit to communicate with Cosasco legacy instruments in hazardous areas. This is done by plugging the Legacy Converter directly into the communications port of the Cosasco legacy instrument.

ER Datalogger

The ER Datalogger (ER-200) was designed to be used together with the Transfer Unit. The ER Datalogger replaces the Remote Data Collector (RDC) that measures corrosion via ER Probe measurements. The ER Datalogger interfaces with all standard Cosasco Electrical Resistance probes and reads both corrosion data and temperature. For convenience, the ER Datalogger communicates with the Transfer Unit via BT Wireless link used as a serial cable replacement.

LPR Datalogger

The LPR Datalogger (LPR-200) was designed to be used together with the Transfer Unit. The LPR Datalogger replaces the Remote Data Collector (RDC) that measures corrosion via LPR Probe measurements. The LPR Datalogger interfaces with all standard Cosasco Electrical Resistance probes and reads both corrosion data and temperature. For convenience, the LPR Datalogger communicates with the Transfer Unit via BT Wireless link used as a serial cable replacement.

Chapter 2

Specifications

Transfer Unit (TU-500)

Battery Requirements:

2 x Cosasco AA Lithium Batteries (P/N 095820)

Operating Temperature:

-40°F to 158°F (-40°C to 70°C)

Dimensions:

6.24”H x 3.35”W x .91”D (15.8 cm x 8.51 cm x 2.31 cm)

LCD:

5 volt, 20 x 4 character LCD screen without backlight

Intrinsic Safety:

ATEX Certification

SIRA 14 ATEX 2263X

Ex ia IIC T4 Ga, Ta = -40°C to +70°C

Enclosure: IP20

For use only with Cosasco Batteries P/N 095820 or P/N 095818, do not mix.

IEC Ex Certification

IECEX SIR 14.0096X

Ex ia IIC T4 Ga, Ta = -40°C to +70°C

Enclosure: IP20 Minimum

For use only with Cosasco Batteries P/N 095820 or P/N 095818, do not mix.

North American Certifications

CSA Certification: 70007061

CSA_{US} Class I, Zone 0, AEx ia IIC T4 Ga, Ta = -40°C to +70°C

cCSA Ex ia IIC T4 Ga, Ta = -40°C to +70°C

Enclosure: IP20 Minimum

For use only with Cosasco Batteries P/N 095820 or P/N 095818, do not mix.

Data Storage:

- Stores up to 255 IDs, with up to 99 Microcor IDs
- ER Probe Reader, LPR Probe Reader,
- RDC – COT, ER Datalogger: 2048 readings without temperature
1024 readings including temperature
- RDC – CAT, LPR Datalogger: 1024 readings without temperature
512 readings including temperature
- Microcor BT Wireless: 16000 readings
- Microcor Legacy: 8000 readings

Transfer Unit (TU-500) (continued)

Battery Life:

Approximately 2 days of continuous operation

Communication:

F as serial cable replacement

Microcor ER Datalogger (M-200)

Battery Requirements:

7.2V Lithium Power Module (P/N 748400)

Operation Temperature:

-40°F to 158°F (-40°C to 70°C)

Dimensions:

4.40"Diameter x 6.9"H (11.2 cm x 17.5cm)

Weight:

6.45lbs (2.9kg)

Operation:

- Compatible with all Cosasco Microcor Probes
- Battery Life: 2 years at 20 min measurement interval

Resolution:

18 bit (1 part in 262,144)

Data Storage:

16,000 Readings (Circular Buffer)

Communication:

Wired/RS232 or Bluetooth v2.0

Bluetooth Specifications:

- Bluetooth v2.0 + EDR
- FHSS/GFSK Modulation
- +2 dBi typical, +4dBi maximum Integral Antenna
- Frequency Range: 2402-2480 MHz

ER Probe Reader (ER-100)

Battery Requirements:

2 x Cosasco AA Lithium Batteries (P/N 095820)

Operating Temperature:

-40°F to 158°F (-40°C to 70°C)

Dimensions:

6.1”H x 2.4”W x 1.44”D (15.5 cm x 6.1 cm x 3.66 cm)

Intrinsic Safety:

ATEX Certification

SIRA 14 ATEX 2261X

Ex ib IIC T4 Gb, Ta = -40°C to +70°C

Enclosure: IP20 Minimum

For use only with Cosasco Batteries P/N 095820 or P/N 095818, do not mix.

IEC Ex Certification

IECEX SIR 14.0094X

Ex ib IIC T4 Gb, Ta = -40°C to +70°C

Enclosure: IP20 Minimum

For use only with Cosasco Batteries P/N 095820 or P/N 095818, do not mix.

North American Certifications

CSA Certification: 70043903

CSA_{US} Class I, Zone 1, AEx ib IIC T4 Gb, Ta = -40°C to +70°C

CSA_C Ex ib IIC T4 Gb, Ta = -40°C to +70°C

Enclosure: IP20 Minimum

For use only with Cosasco Batteries P/N 095820 or P/N 095818, do not mix.

Operation:

- Compatible with all Cosasco ER Probes
- Battery Life: 1700 Readings

Communication:

Bluetooth® as serial cable replacement

LPR Probe Reader (LPR-100)

Battery Requirements:

2 x Cosasco AA Lithium Batteries (P/N 095820)

Operating Temperature:

-40°F to 158°F (-40°C to 70°C)

Dimensions:

6.1”H x 2.4”W x 1.44”D (15.5 cm x 6.1 cm x 3.66 cm)

Intrinsic Safety:ATEX Certification

SIRA 14 ATEX 2262X

Ex ib IIC T4 Gb, Ta = -40°C to +70°C

Enclosure: IP20

For use only with Cosasco Batteries P/N 095820 or P/N 095818, do not mix.

IEC Ex Certification

IECEX SIR 14.0095X

Ex ib IIC T4 Gb, Ta = -40°C to +70°C

Enclosure: IP20 Minimum

For use only with Cosasco Batteries P/N 095820 or P/N 095818, do not mix.

North American Certifications

CSA Certification: 70007055

CSA_{US} Class I, Zone 1, AEx ib IIC T4 Gb, Ta = -40°C to +70°C

CSA_C Ex ib IIC T4 Gb, Ta = -40°C to +70°C

Enclosure: IP20 Minimum

For use only with Cosasco Batteries P/N 095820 or P/N 095818, do not mix.

Operation:

- Compatible with all Cosasco LPR Probes
- Battery Life: 2000 Readings

Communication:

Bluetooth® as serial cable replacement

Legacy Converter (LC-500)

Battery Requirements:

2 x Cosasco AA Lithium Batteries (P/N 095820)

Operating Temperature:

-40°F to 158°F (-40°C to 70°C)

Dimensions:

4.0”H x 2.5”W x 1.3”D (10.3 cm x 6.4 cm x 3.3 cm)

Intrinsic Safety:ATEX Certification

SIRA 14 ATEX 2264X

Ex ib IIC T4 Gb, Ta = -40°C to +70°C

Enclosure: IP20

For use only with Cosasco Batteries P/N 095820 or P/N 095818, do not mix.

IEC Ex Certification

IECEX SIR 14.0097X

Ex ib IIC T4 Gb, Ta = -40°C to +70°C

Enclosure: IP20 Minimum

For use only with Cosasco Batteries P/N 095820 or P/N 095818, do not mix.

North American Certifications

CSA Certification: 70008374

CSA_{US} Class I, Zone 1, AEx ib IIC T4 Gb, Ta = -40°C to +70°C

CSA_C Ex ib IIC T4 Gb, Ta = -40°C to +70°C

Enclosure: IP20 Minimum

For use only with Cosasco Batteries P/N 095820 or P/N 095818, do not mix.

Operation:

- Compatible with all Cosasco legacy instruments (Excluding RDC 4 Channel)
- Battery Life: Approximately 2 days of continuous operation

Communication:

Bluetooth® as serial cable replacement

ER Datalogger (ER-200)

Battery Requirements:

Cosasco RDC2 Battery Pack P/N 726043

Operating Temperature:

-40°F to 158°F (-40°C to 70°C)

Dimensions (Approximately):

9.05”H x 6.5”W x 4.25”D (22.987 cm x 16.51 cm x 10.795 cm)

Intrinsic Safety:

ATEX and UKCA Certification

SIRA 16ATEX2024X

CSAE 21UKEX2568X

Ex ia IIC T4 Ga, Ta = -40°C to +70°C

For use only with RCS RDC2 Battery Pack P/N 726043

Enclosure: IP20

IEC Ex Certification

IECEX SIR 16.0009X

Ex ia IIC T4 Ga, Ta = -40°C to +70°C

For use only with RCS RDC2 Battery Pack P/N 726043

Enclosure: IP20 Minimum

North American Certifications

CSA Certification: 70008419

CSA_{US} Class I, Zone 0, AEx ia IIC T4 Ga, Ta = -40°C to +70°C

CSA Ex ia IIC T4 Ga, Ta = -40°C to +70°C

For use only with RCS RDC2 Battery Pack P/N 726043

Enclosure: IP20 Minimum

Operation:

- Compatible with all standard Cosasco ER Probes
- Battery Life: 1.9 years at 1 measurement every 4 hours

Communication:

Bluetooth® as serial cable replacement

LPR Datalogger (LPR-200)

Battery Requirements:

Cosasco RDC2 Battery Pack P/N 726043

Operating Temperature:

-40°F to 158°F (-40°C to 70°C)

Dimensions (Approximately):

9.05”H x 6.5”W x 4.25”D (22.987 cm x 16.51 cm x 10.795 cm)

Intrinsic Safety:ATEX and UKCA Certification

SIRA 16ATEX2025X

CSAE 21UKEX2522X

Ex ia IIC T4 Ga, Ta = -40°C to +70°C

For use only with RCS RDC2 Battery Pack P/N 726043

Enclosure: IP20

IEC Ex Certification

IECEX SIR 16.0010X

Ex ia IIC T4 Ga, Ta = -40°C to +70°C

For use only with RCS RDC2 Battery Pack P/N 726043

Enclosure: IP20 Minimum

North American Certifications

CSA Certification: 70014313

CSA_{Us} Class I, Zone 0, AEx ia IIC T4 Ga, Ta = -40°C to +70°C

CSA Ex ia IIC T4 Ga, Ta = -40°C to +70°C

For use only with RCS RDC2 Battery Pack P/N 726043

Enclosure: IP20 Minimum

Operation:

- Compatible with all standard Cosasco LPR Probes
- Battery Life: 1 year at 1 reading every 4 hours

Communication:

Bluetooth® as serial cable replacement

Chapter 3

Basics of the BT Wireless Suite

Transfer Unit

Battery Installation

The Transfer Unit is supplied with two 3.6 Volt AA lithium batteries. To install these batteries, remove the rear access panel of the unit with a screwdriver and install the batteries with the polarities as indicated on the unit. Replace the rear access panel when finished.



TU-500 Transfer Unit
Front View

TU-500 Transfer Unit
Back View

Standby Screens

The **Standby Screens** are shown below. To navigate between the two standby screens use the More and Back options.



Scanning for Devices

To scan for devices, select the Scan option on the standby screen. The following screen will appear. Select an amount of time, 10s, 20s, or 30s, to scan for devices.

Note: It is recommended to use the 30s scan time to allow for BT Wireless to sync.

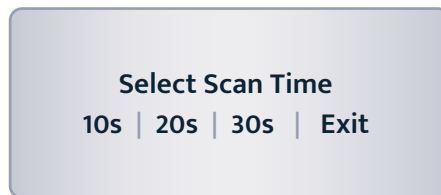

The Transfer Unit will show the following screens while scanning for devices.

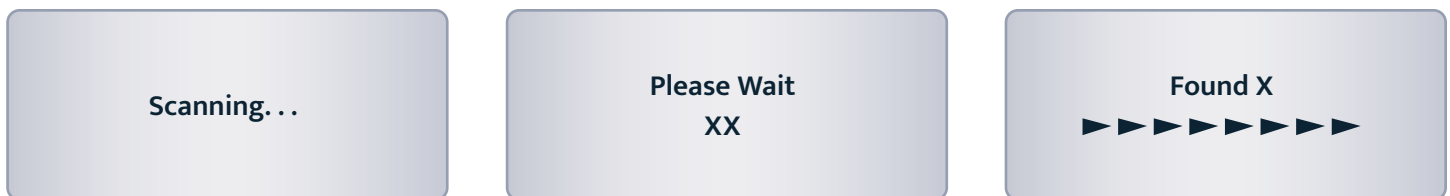

When the Transfer Unit has finished scanning, scroll through the list of found devices using the up and down arrows on the keypad. The user can select **Sv** to save the device to a list.

Note: Up to 10 devices can be stored into the saved device list.

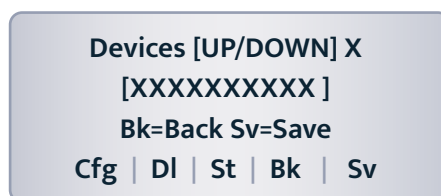

Device List

After scanning for devices, the Transfer Unit allows the user to view the devices found from the last scan or view the list of saved devices. These options allow the user to bypass the scanning command and directly access a list of devices.

From the Standby screen select **Device**.

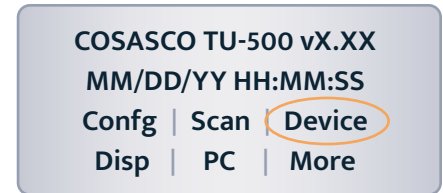

On this screen, the user will have the option for **Last Scan**, **Saved List** and **Exit**.

- **Last Scan** will bring the user to the list of devices from the last scan.
- **Saved List** will bring the user to the list of saved devices.
- **Exit** will return the user to the standby screen.

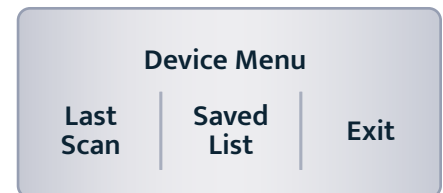

Display Configured IDs

The Transfer Unit gives the user the option to view configured ID's through the standby screen.

On the standby screen select **Disp**.

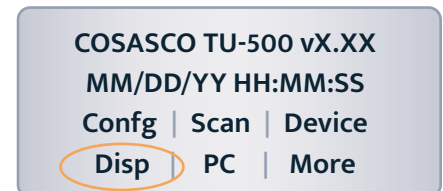

On the following screen, the user has the option to display configured ID's by selecting either **Current** or **ID**. If **Current** is selected the Transfer Unit will display the last viewed ID and if **ID** is selected the Transfer Unit will allow the user to enter a device's ID number. Different information will be displayed depending on the type of ID configured.

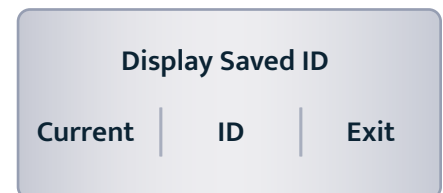

Setting Units

To change the units on the Transfer Unit select **Units** from the standby screen. The following screen will appear with the options for Temperature being **F** (Fahrenheit) and **C** (Celsius) and the options for Metal Loss being **mils**, **µm**, and **mm**.

The option that is currently selected for temperature or metal loss will be shown next to **Temperature** and **Metal Loss** respectively. To change the units, navigate to the preferred unit then hit **OK**. When finished selecting the units, select **Back** to return to the standby screen.



Setting Time

To change or set the time on the Transfer Unit select **Time** from the standby screens. The following screen will appear with the options for Mate and Zone.

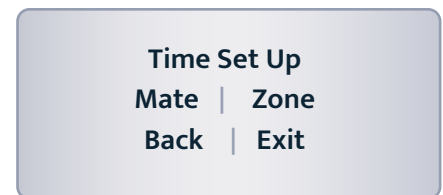

Choosing **Mate** will take the user to the following screen and allow the user to manually enter the time and date in military time.

YY – Year, **MM** – Month, **DD** – Day of the month,
dd – Day of the week where 00 is Sunday,
hh – Hours, **mm** – Minutes, **ss** – Seconds

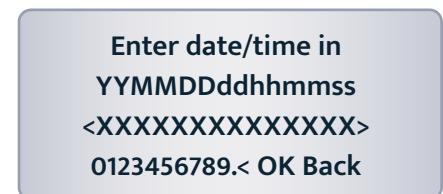

Choosing **Zone** will take the user to the following screen and will allow the user to select a time zone and an offset. Select either **STZ** (**Standard Time Zone**) or **DTZ** (**Daylight Time Zone**) and scroll up and down using the up / down arrows on the keypad to change the offset.

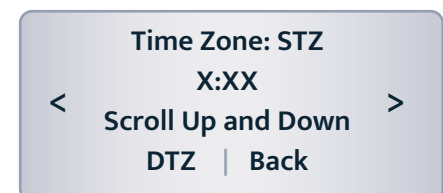

Clearing Memory

From the standby screen select the option **Memory**. The following screen will appear with the options to clear memory for a specific device's **ID** number, **Units**, **Device** or **All**.

- If the user selects **ID**, enter the ID number of the device to delete the data off the Transfer Unit then select **OK**. On the next display screen select Okay to clear the data for that ID. This will clear all of the data stored for this specific ID including configuration and data.
- If the user selects **Units**, the preferences for the units stored on the Transfer Unit will be restored to the defaults. Temp: C, Metal loss: mils, Time zone: STZ, -8:00 offset.
- If the user selects **Device**, this will clear the memory for saved scan BT devices and last scanned BT devices.
- If the user selects **All**, this will clear all stored ID numbers configuration and data, restore all units to their default and clear all stored scanned devices.

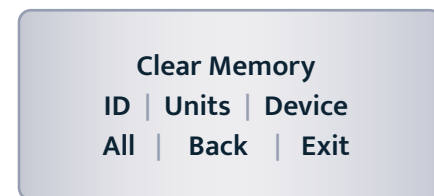

Microcor ER Datalogger

Power Module Installation

Power Module (Cosasco P/N 748400) is intrinsically safe and may be connected/disconnected in a hazardous location.

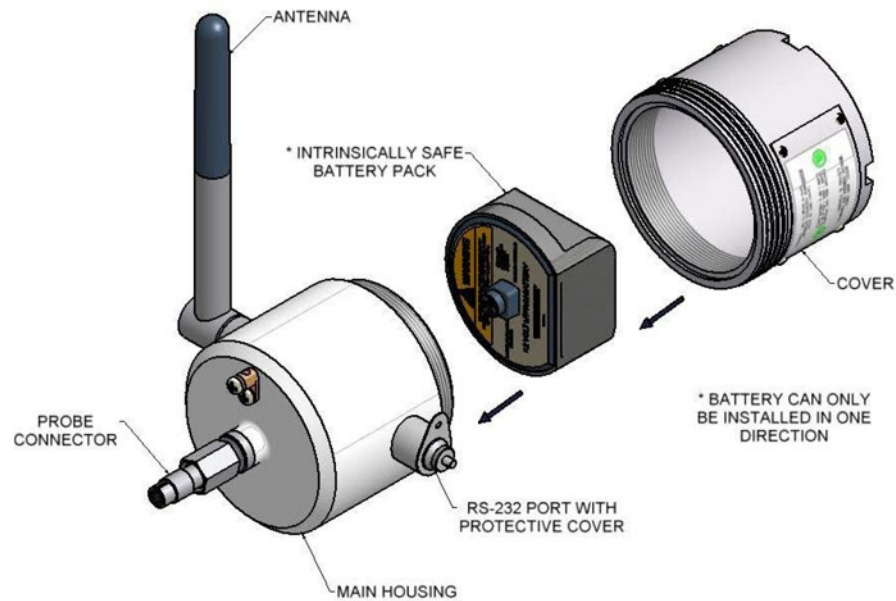

Configuration for hazardous/non-hazardous locations.
(computer software may only be used in a non-hazardous location)

Mounting the Microcor ER Datalogger

The Microcor ER Datalogger can be installed on the top, side or bottom of the line according to the probe installation. Choose the best installation configuration that corresponds to the location of the probe.

Grounding

A 8 to 14 AWG grounding wire can be attached to the datalogger at the grounding lug. Connect the ground wire to earth ground per local electrical code.

Mounting the Microcor ER Datalogger (continued)

Direct Probe Mounting**Top of the Line**

1. Attach connector and tighten connector nut to mount the transmitter to the probe adapter.
2. Rotate the antenna to vertical position.

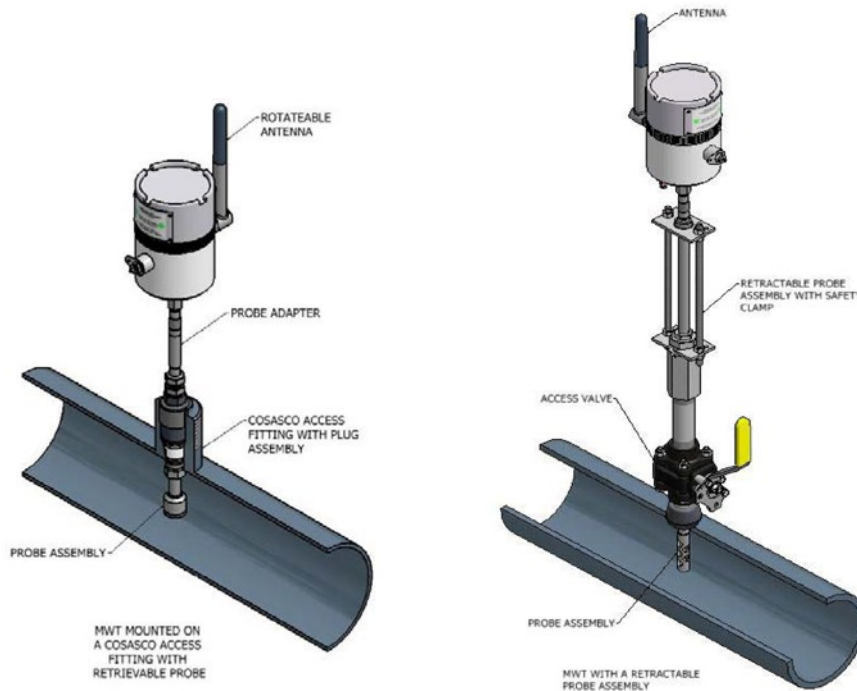
**Side of the Line**

1. Attach connector and tighten connector nut to mount the transmitter to the probe adapter.
2. Rotate the antenna to vertical position.

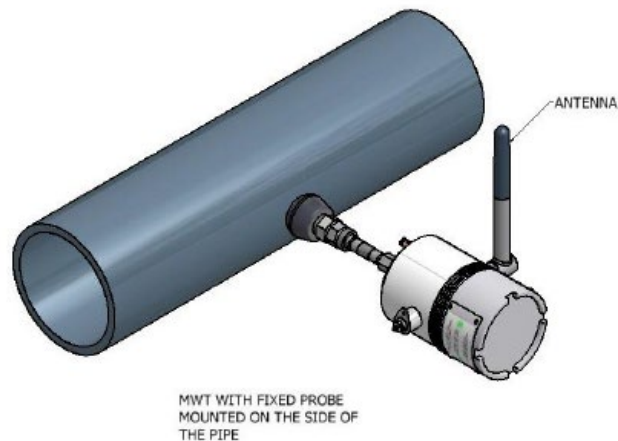

Mounting the Microcor ER Datalogger (continued)

Bottom of the Line

1. Attach connector and tighten connector nut to mount the transmitter to the probe adapter.
2. Rotate the antenna to vertical position.

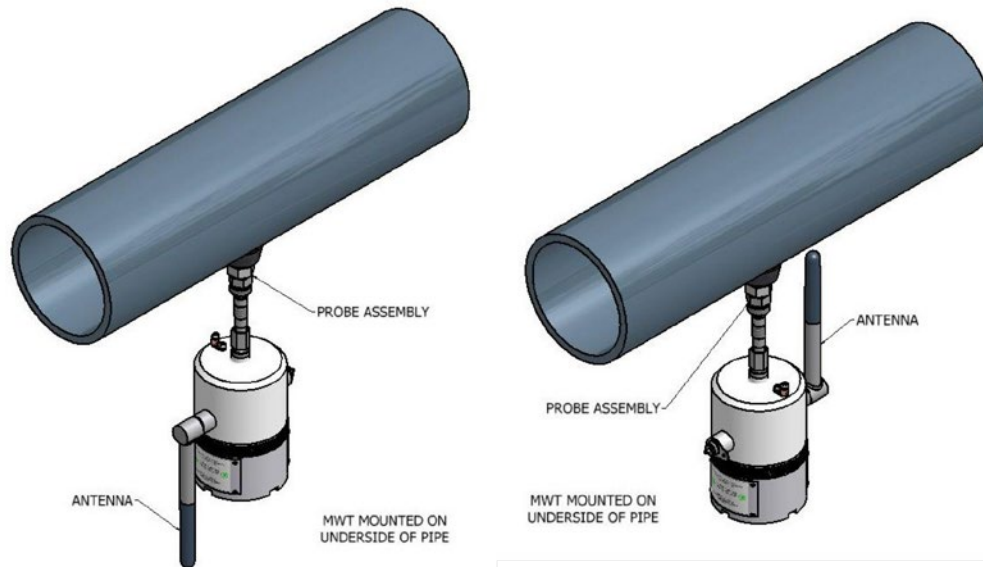
**Optional Remote Mounting** (Bottom of the Line shown)

1. Secure the transmitter to the remote mounting post using appropriate accessories.
2. Attach connector and tighten connector nut of the optional flexible cable to the probe adapter and attach the other end to the transmitter.
3. Rotate the antenna to vertical position.

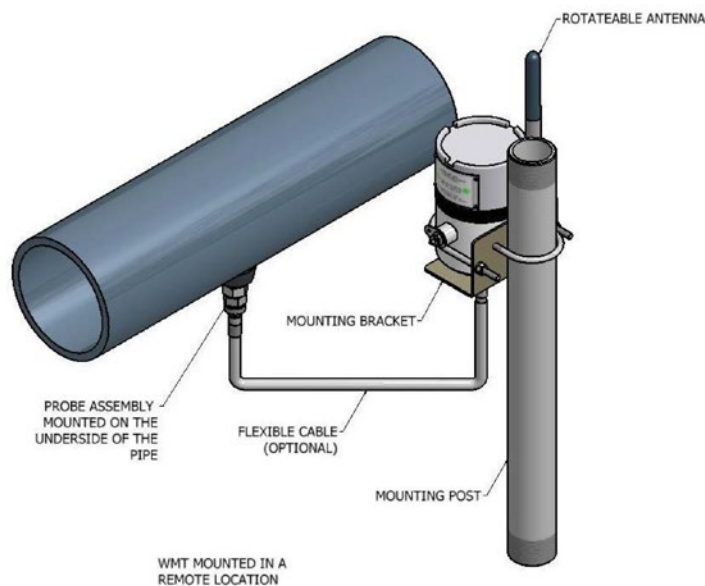

Cosasco Mounting Accessories

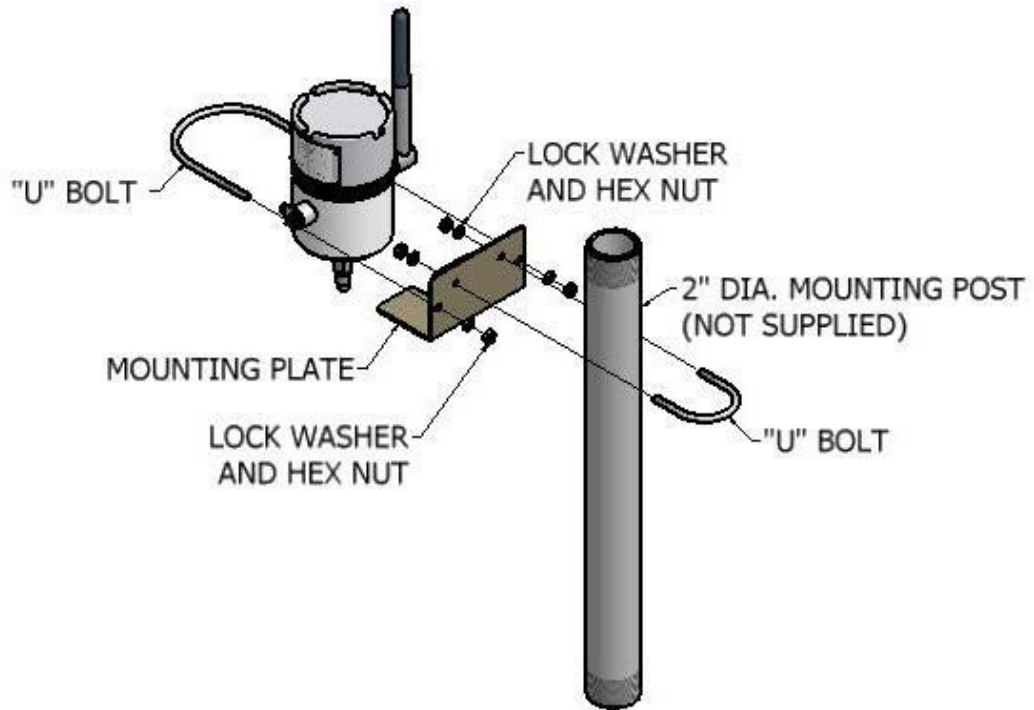

ER Probe Reader and LPR Probe Reader

Battery Installation

Both Probe Readers are supplied with two 3.6 Volt AA lithium batteries. To install these batteries, remove the rear access panel of the unit with a screwdriver and install the batteries with the polarities as indicated on the unit. Replace the rear access panel when finished.



ER-100 Probe Reader
Front View

ER-100 Probe Reader
Back View

Checking Battery Status

To check the battery status of the Probe Readers, turn on the Probe Reader by pushing the power button on the top of the device. If the LED on the top of the device is green, the Probe Reader has good batteries. If the LED on the top of the device is red or unit does not respond, the user needs to change the batteries of the Probe Reader before taking a reading. Replace batteries as indicated on the [ER Probe Reader and LPR Probe Reader Battery Installation](#) section.



ER-100 Probe Reader
Top View

Using the ER Probe Reader

To use the ER Probe Reader, the user must first attach the ER Probe Reader to an **ER Probe/Probe Adapter**.

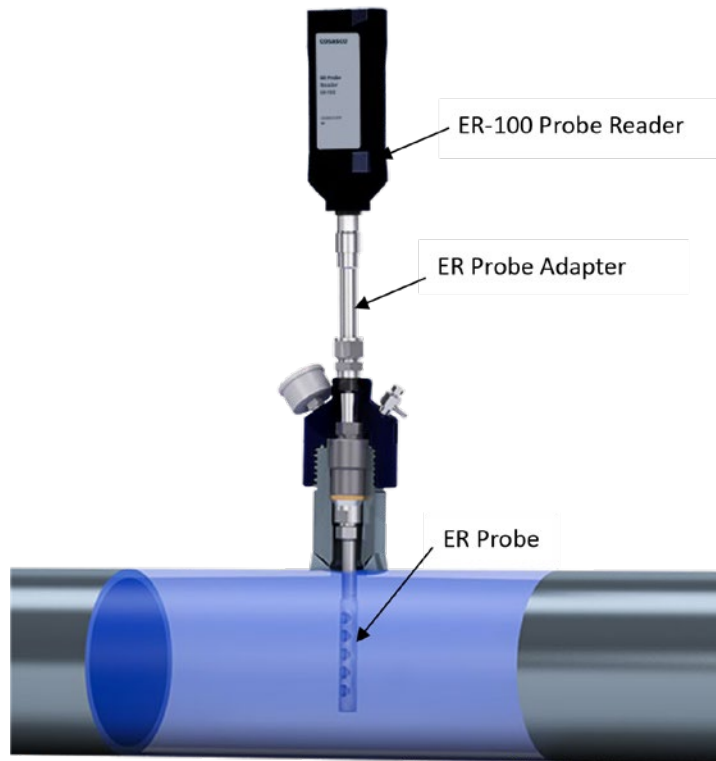

Turn on the ER Probe Reader by pushing the power button on the top of the device. The LED of the ER Probe Reader will be green when ready to take a probe reading. When the ER Probe Reader is taking a reading of the probe, the LED will be **yellow/orange**. When the ER Probe Reader has finished taking a reading of the probe, the LED will return back to **green**.

Using the LPR Probe Reader

To use the LPR Probe Reader, the user must first attach the LPR Probe Reader to an LPR Probe/Probe Adapter.

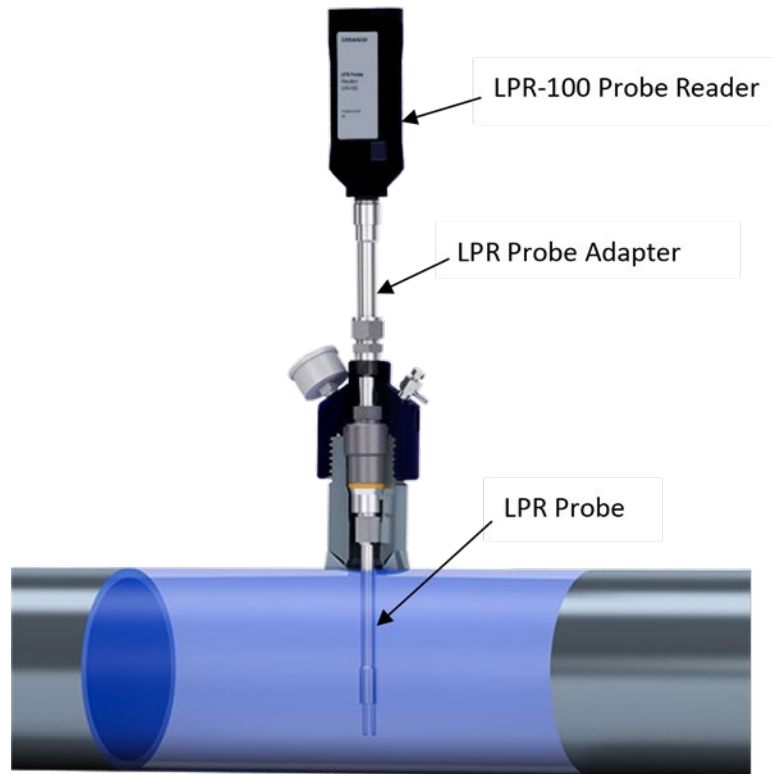

Turn on the LPR Probe Reader by pushing the power button on the top of the device. The LED of the LPR Probe Reader will be **green** when ready to take a probe reading. When the LPR Probe Reader is taking a reading of the probe, the LED will be **yellow/orange**. When the LPR Probe Reader has finished taking a reading of the probe, the LED will return back to **green**.

Turn Off Probe Readers

To turn off the ER Probe Reader or LPR Probe Reader, push and hold down the power button until the LED turns **red**.

Legacy Converter

Battery Installation

The Legacy Converter is supplied with two 3.6 Volt AA lithium batteries. To install these batteries, remove the rear access panel of the unit with a screwdriver and install the batteries with the polarities as indicated on the unit. Replace the rear access panel when finished.

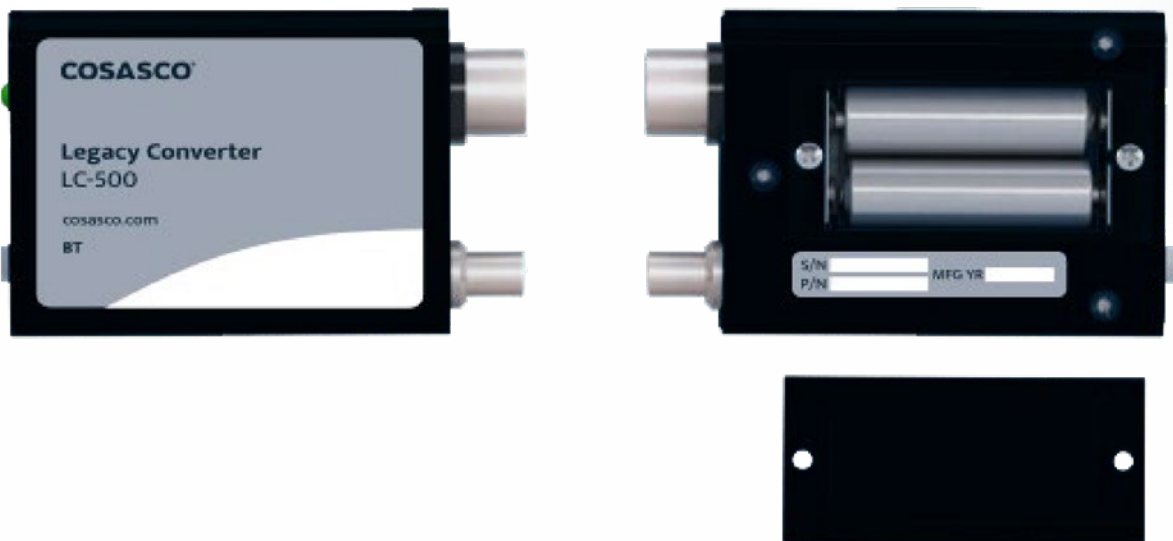

LC-500 Front View

LC-500 Back View

Checking Battery Status

To check the battery status of the Legacy Converter, turn on the device by pushing down the power button. If the LED on the device does not flash **green** after approximately 2 seconds the user needs to change the batteries. Replace batteries as indicated on the [Legacy Converter Battery Installation](#) section.



LC-500 Converter Top View

Using the Legacy Converter

Attach the Legacy Converter directly to the communications port of the Cosasco Legacy Device.

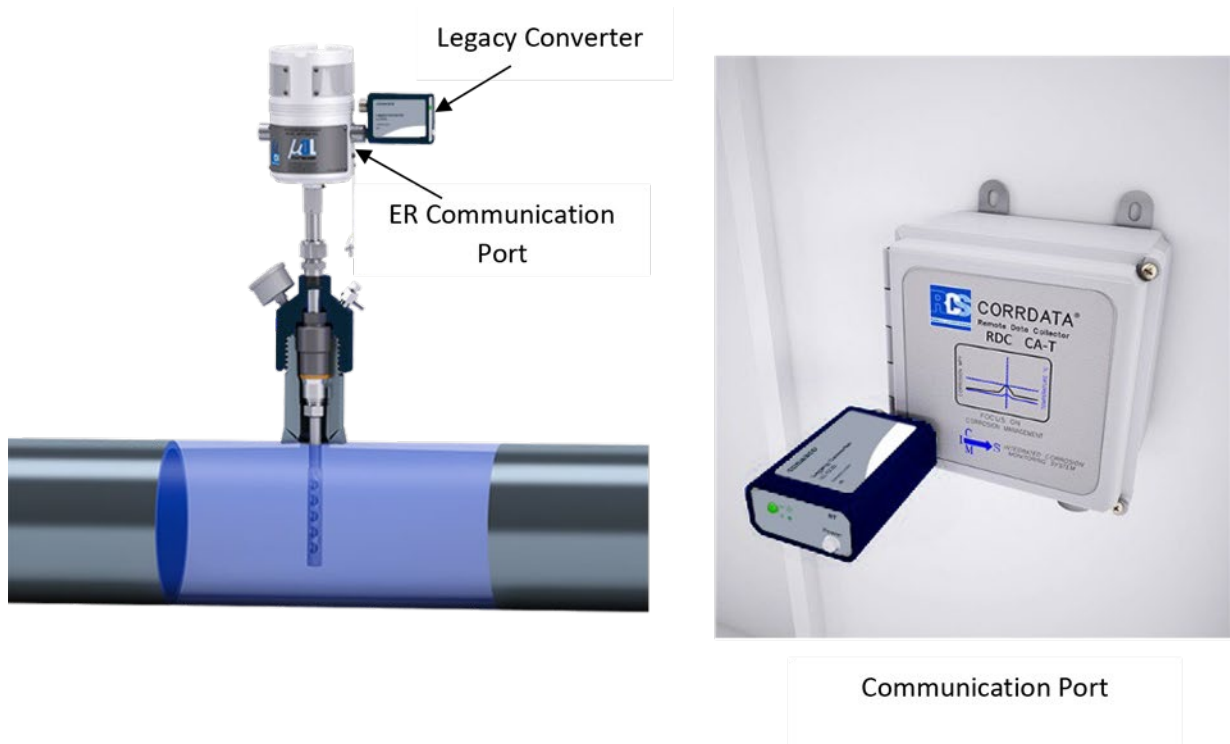

Turn on the device by pushing the white power button. The LED on the Legacy Converter will flash green when ready to be used with the Transfer Unit.

Turn Off Legacy Converter

To turn off the Legacy Converter, push the white power button and the LED will turn off.



ER Datalogger and LPR Datalogger

Battery Installation

Note: If LED flashes green when battery is installed, use the TU-500 to download data and reconfigure the Datalogger.

Both Dataloggers are supplied with a battery pack (Cosasco P/N 726043). To install this battery pack, open the unit by releasing the latches, remove the thumb screws and washers, place the battery onto the screw mounts and make sure the arrows are pointing upwards, insert the washers, hand tighten the thumb screws and connect the power connectors together. Once finished, close the unit by re-latching the latches.

Installation

Note: THE FOLLOWING ARE ONLY RECOMMENDED PRACTICES. INSTALLATION OF THIS DATALOGGER IN AN EXPLOSIVE ENVIRONMENT MUST BE IN ACCORDANCE WITH THE REQUIREMENTS FOR INSTALLATION OF INTRINSICALLY SAFE SYSTEMS IN HAZRDOUS (CLASSIFIED) LOCATIONS, PER LOCAL CODE SUCH AS THE NATIONAL ELECTRIC CODE (ANSI/NFPA70)

Location

The ER and LPR Dataloggers are certified for Zone 0 Hazardous Environment operation. The Dataloggers are designed for continuous operation between -40°C to 70°C. If extremes are expected outside of this operation range, sufficient protection to the thermal differences should be used for optimal lifespan of the device.

Mounting the Device

The ER and LPR Dataloggers cannot be directly mounted to a probe and are typically remote mounted with a 10' (typical) probe cable connecting to a probe location. A typical ER Datalogger or LPR Datalogger mounting example is shown below



ER Datalogger and LPR Datalogger Installation (continued)

Two common ways to mount the device are **remote wall mounting** and **2” pipe mounting**.

Remote wall mounting: Ensure the device is mounted vertically with the probe cable entrance pointed down.

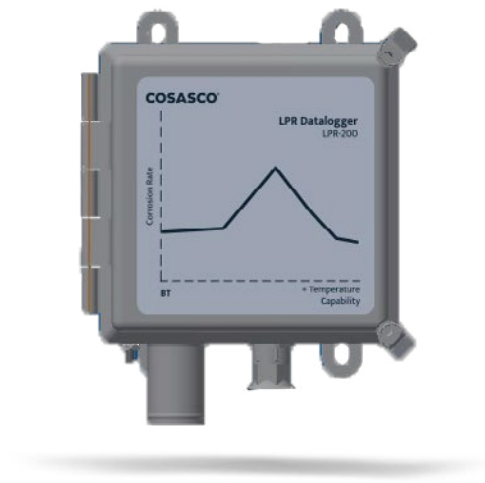

Pipe mounting: This mounting technique is for the [Fiberglass Enclosure](#) only. Mount the device to the mounting plate and attach the U bolts around the pipe and secure with the nuts.

Note: Only the U bolts will be provided.

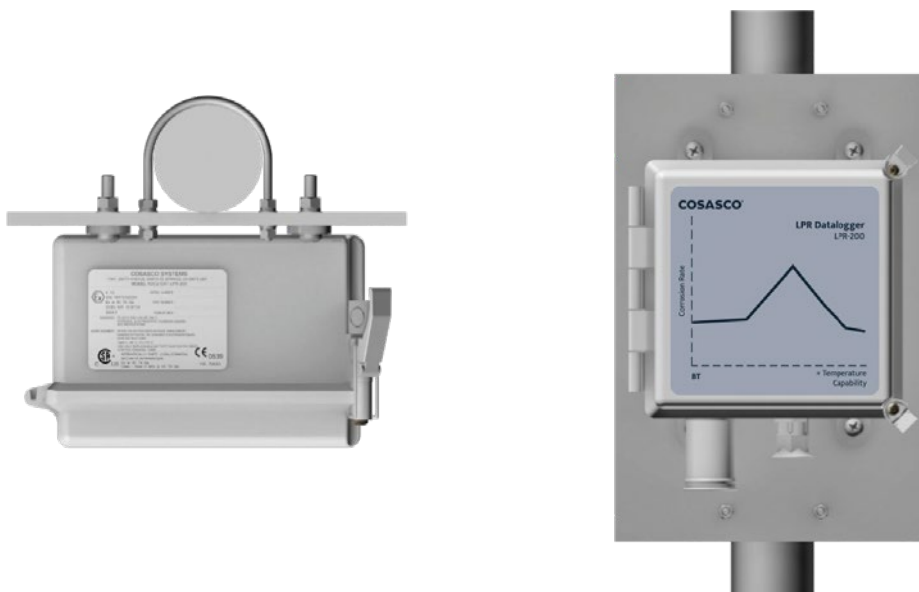

Grounding

This is applicable to the ER-200 or LPR-200 Stainless Steel enclosure and units with remote mounted antenna.

An 8 to 14 AWG grounding wire can be attached to the Datalogger at the mounting hole. Install grounding wire per local Electric code.

Attach a grounding wire into the lightning arrester and enclosure if the remote mount antenna is used.

**Mounting the Remote Mount Antenna**

The remote mount antenna is provided with the installation hardware. This uses a U bolt for installation.

Secure the antenna to the mounting location using the U bolt. After the antenna is secured apply the provided sealing tape to both Lightning arrester and to antenna connector to help ensure maximum device lifespan.



Chapter 4

Transfer Unit

Microcor ER Datalogger

Create an ID for Microcor ER Datalogger

On the standby screen of the Transfer Unit select **Config**. On the next display screen, select **Microcor** to get to a list of Microcor devices.



Select **M-200** for the Microcor ER Datalogger (M-200).

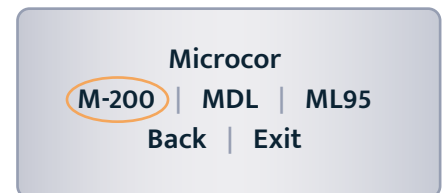

Enter the desired **ID** number then select **OK**.

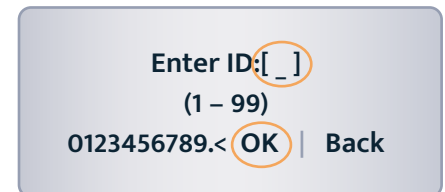

Enter the interval then select **m** for minutes.

Note: the hours (**h**) option is disabled and will show **INVAL** if selected.

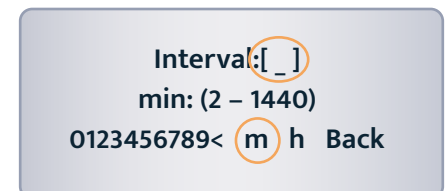

Create an ID for Microcor ER Datalogger (continued)

Enter a tag name for the device then select **Nxt**.

Tag:[_ _ _ _]
 ABCDEFGHIJKLMNOPQRSTU-
 VWXYZ0123456789._-<
 Clr | **Nxt** | Bck | Exit

To save the configuration of the device select **Okay**.

Save?
 ID: XX TAGNAME
Okay | Back | Exit

Load ID onto Microcor ER Datalogger

To load a configuration onto the Microcor ER Datalogger an ID must be created. If the user has not already created an ID, please refer to the **Create an ID** section.

On the Transfer Unit, scroll through the list of Devices until the BT Wireless name of the desired Microcor ER Datalogger device is displayed then select **Cfg**.

Devices [UP/DOWN] X
 [XXXXXXXXXX]
 Bk=Back Sv=Save
Cfg | DI | St | Bk | Sv

Enter the **ID** of the configuration to load onto the Microcor ER Datalogger then select **OK**.

Enter ID:[_ _]
 (1 - 99)
 0123456789.< **OK** | Back

Select **Okay** to load the configuration onto the Microcor ER Datalogger.

Save?
 ID: XX TAGNAME
Okay | Back | Exit

Download Data from Microcor ER Datalogger

On the Transfer Unit device list, navigate to the Microcor ER Datalogger device and select **DI**.

Devices [UP/DOWN] X
[XXXXXXXXXX]
Bk=Back Sv=Save
Cfg | **DI** | St | Bk | Sv

After the transfer of data from the Microcor ER Datalogger to the Transfer Unit is complete, the following screen will display the Microcor ER Datalogger ID number, tag name and the number of samples collected with the interval they are being collected at.

ID:XX M-200
Tag: XXXXXXXX
Samples: XXXX (XX m/h)
Next | Back | Exit

Select **Next** to continue to the next display which shows Probe Life Units (PLU).

PLU: XXXXX
Next | Back | Exit

Select **Next** to continue to the next display to see the time when the last data point was collected and what intervals the data is being taken at.

Time Stamp:
MM/DD/YY HH:MM:SS
Interval: (XX m/h)
Back | Exit

Read Microcor ER Datalogger Status

On the Transfer Unit device list, navigate to the Microcor ER Datalogger device and select **St**.

```

Devices [UP/DOWN] X
[XXXXXXXXXXXX ]
Bk=Back Sv=Save
Cfg | DI | St | Bk | Sv
  
```

After a successful data transfer, the following screen will appear with the attached information. Select **Next** to continue to the next display which shows the current time on the Microcor ER Datalogger.

```

ID:XX TAGNAME
Samples: XXXX
Interval: XX m/h
Next | Back | Exit
  
```

```

Current Time:
MM/DD/YY HH:MM:SS
Next | Back | Exit
  
```

Select **Next** to continue to the next display which shows the battery, memory and transmitter information as shown below. Battery status will show **good** or **low**. Memory and transmitter will show **good** or **bad** depending on their status.

```

Battery: Good/Low
Memory: Good/Bad
Transmitter: Good/Bad
Back | Exit
  
```

Chapter 5

ER Probe Reader

The Transfer Unit is used with the ER Probe Reader to utilize all of the ER Probe Reader functions. Refer to **Basics of the BT Wireless Suite – ER Probe Reader and LPR Probe Reader** for more information on how to use the ER Probe Reader.

Create an ID for ER Probe Reader

On the Transfer Unit standby screen select **Config**. On the next display screen, select **ER** to get to a list of ER devices.

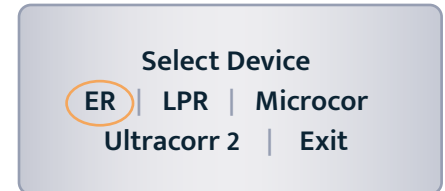

Select **Reader** from the list of devices.

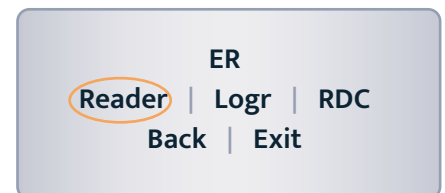

Enter the desired ID number then select **OK**.

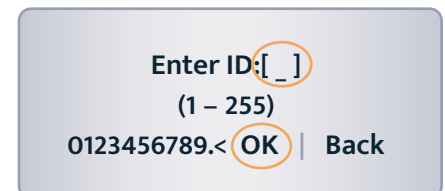

Enter a tag name for the device then select **Nxt**.



Create an ID for ER Probe Reader (continued)

Enter a tag name of the alloy then select **Nxt**.

Note: The name of the alloy is for reference only and does not affect the calculation of corrosion rates.

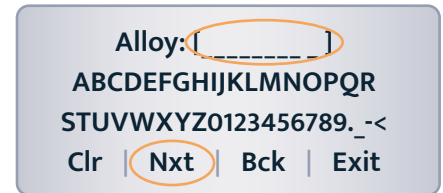

Select the probe type used with the Reader then select **Next**.

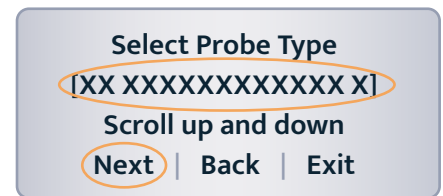

If the user selects any of the **Other** probe options, the following screen will appear. Manually enter the span of the probe.

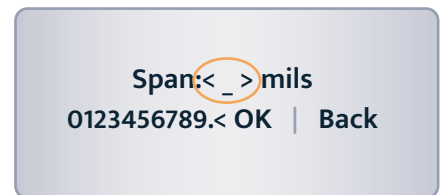

Select if the probe is a temperature probe or not by selecting either **Yes** or **No**.

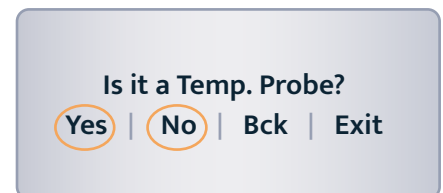

To save the ID select **Okay**.

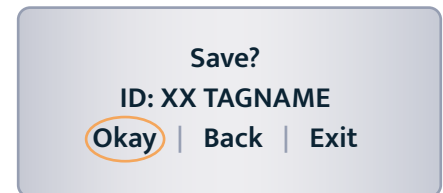

Take Data Point

On the Transfer Unit device list screen, navigate to the ER Probe Reader and select **Read**.

Devices [UP/DOWN] X
[XXXXXXXXXX]
Bk=Back Cl=Clear
Read | DI | Bk | Cl

The user will have the option to either select **ID** or **Quick** to read the probe connected to the Reader.

- If **ID** is selected, the user will need to enter an ID preconfigured for the ER Probe Reader to take the data of and select **OK**. On the confirmation screen select **Okay** and the reader will begin to read the probe.

Enter ID: [___]
(1-255)
0123456789.<**OK** | Back

ID: XXX TAGNAME
Okay | Back | Exit

Note: If the user has not already created an ID, please refer to the **Create an ID for Reader** section for the ER Probe Reader.

- If **Quick** is selected, the user will need to manually enter the probe type, the span of the probe, and if the probe is a temperature probe or not.

Once one of the previous steps is completed, the ER Probe Reader will take a reading of the attached probe. The ER Probe Reader has finished taking a reading once the ER Probe Reader light goes from yellow/orange back to blinking green.

Select Probe Type
A | B | C | D
G | u | Back | Exit

Span: <__>mils
0123456789.< OK | Back

Is it a Temp. Probe?
Yes | **No** | Bck | Exit

Download Data Point from Reader

Before Downloading Data from the Reader, the user must first take a reading from the Reader. If this has not been done, please refer to the **Take Data Point** section.

Once the user finds an ER Probe Reader to download data from on the Transfer Unit select **DI**.

After the transfer of the data point from the Reader to the Transfer Unit is complete, a screen will display information about the data on the Reader including the Divisions and Check Readings, Temperature, Metal Loss and the time that the last data point was collected from the device.

To save the current data to the Transfer Unit select **Save**.

Note: This option will only be available if the user read from the Reader using a pre-configured ID.

Devices [UP/DOWN] X
[XXXXXXXXXX]
Bk=Back Cl=Clear
Read | **DI** | Bk | Cl

Div: XXX.X Chk: XXX.X
Temp: XXXX.X C
MLoss: X.XXX mils
Next | Back | Exit

Time Stamp:
MM/DD/YY HH:MM:SS
Save | Back | Exit

Chapter 6

LPR Probe Reader

The Transfer Unit is used with the LPR Probe Reader to utilize all of the LPR Probe Reader functions. Refer to **Basics of the BT Wireless Suite – ER Probe Reader and LPR Probe Reader** for more information on how to use the ER Probe Reader.

Create an ID for LPR Probe Reader

On the Transfer Unit standby screen select **Config**. On the next display screen, select **LPR** to get to a list of ER devices.

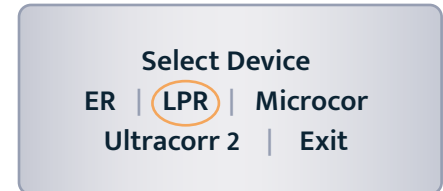

Select **Reader** from the list of devices.

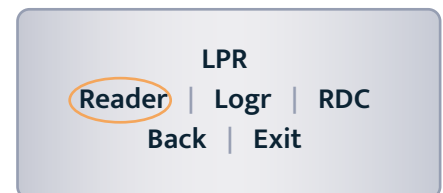

Enter the desired ID number then select **OK**.

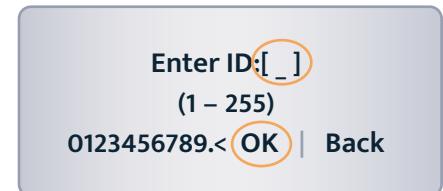

Enter a tag name for the device then select **Nxt**.



Create an ID for LPR Probe Reader (continued)

Select an alloy by using the up and down arrows to scroll through the choices then select **Next**.

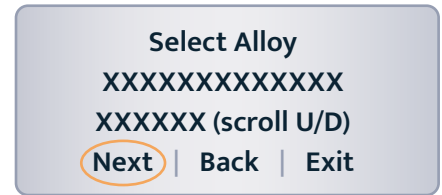

If **Other** is selected, the name of the alloy and the multiplier (mult) will have to be inputted manually.

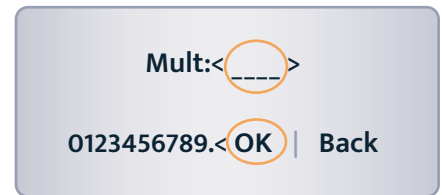
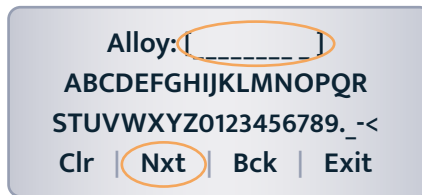

Select either **Stdrd-E** or **Flush-F** for the probe type.

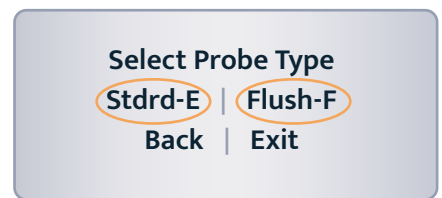

Select the cycle time in minutes for the device (5, 10, 15 or 20).

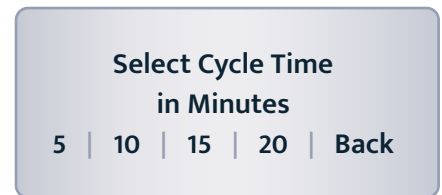

Select if the probe is a temperature probe or not (**Yes** or **No**).

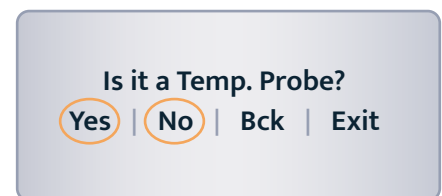

To save the configuration of the device select Okay.

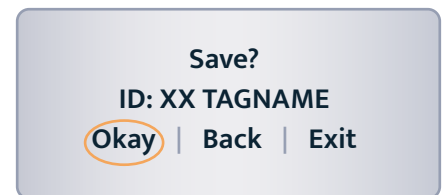

Download Data Point from Reader

Before Downloading Data from the Reader, the user must first take a reading from the Reader. If this has not been done, please refer to the **Take Data Point** section.

On the Transfer Unit devices list screen, navigate to the LPR Probe Reader then select **DI**.

After a successful data transfer, a screen will display information about the data in the Reader including the Rate, Imbalance, Temperature and the time that the last data point was collected from the device.

To save the current data to the Transfer Unit select **Save**.

Note: This option will only be available if the user read from the Reader using a pre-configured ID.

Devices [UP/DOWN] X
[XXXXXXXXXXXX]
Bk=Back Cl=Clear
Read | **DI** | Bk | Cl

Rate: XXX mpy
Imb: XX.XXX
Temp: XXX
Next | Back | Exit

Time Stamp:
MM/DD/YY HH:MM:SS
Save | Back | Exit

Chapter 7

Legacy Converter

The Transfer Unit is used with the Legacy Converter to utilize all of the Legacy Converter functions. Refer to **Basics of the BT Wireless Suite – Legacy Converter** for more information on how to use the Legacy Converter.

RDC-CO(T)

To use the Transfer Unit with the RDC-CO(T), a Legacy Converter must be connected to the RDC-CO(T)'s service port to allow for communication between devices.

Create an ID for RDC-CO(T)

On the Transfer Unit standby screen select **Config**. On the next display screen, select **ER** to get to a list of Corrosometer devices.

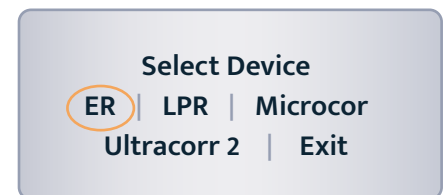

Select **RDC** from the list of devices.

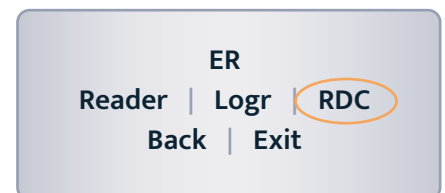

Enter the desired ID number then select **OK**.

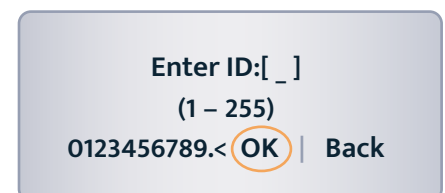

Create an ID for RDC-CO(T) (continued)

Enter the interval then select **m** for minutes or **h** for hours.

Interval: [_]
 min:(5-30) hr:(1-24)
 0123456789 < **m h** Back

Enter a tag name for the device then select **Nxt**.

Tag: [_]
 ABCDEFGHIJKLMNOPQRSTU-
 VWXYZ0123456789._-<
 Clr | **Nxt** | Bck | Exit

Enter in the name of the alloy then select **Nxt**.

Note: The name of the alloy is for reference only and does not affect the calculation of corrosion rates.

Alloy: [_____]
 ABCDEFGHIJKLMNOPQR
 STUVWXYZ0123456789._-<
 Clr | **Nxt** | Bck | Exit

Select the probe type used with the RDC-CO(T) then select **Next**.

Select Probe Type
 < XX XXXXXXXXXXXX X >
 Scroll up and down
Next | Back | Exit

If the user selects any of the **Other** probe options, the following screen will appear. Manually enter the span of the probe.

Span: < [_] > mils
 0123456789.< **OK** | Back

Select if the probe is a temperature probe or not by selecting either **Yes** or **No**.

Is it a Temp. Probe?
Yes | **No** | Bck | Exit

To save the configuration of the device select **Okay**.

Save?
 ID: XX TAGNAME
Okay | Back | Exit

Load Configuration onto RDC-CO(T)

To load a configuration onto the RDC-CO(T) an ID must be created. If the user has not already created an ID, please refer to the **Create an ID for RDC-CO(T)** section.

On the device list screen, find the Legacy Converter device by pushing the up and down keys and select **Cfg**.

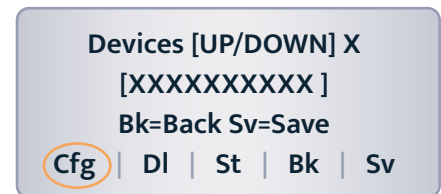

On the following screen, select **RDC-COT**.

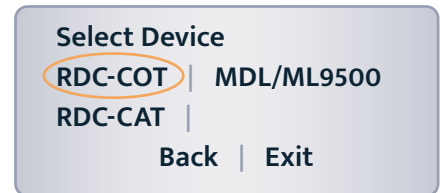

Enter the ID of the configuration to load onto the RDC-CO(T) then select **OK**.

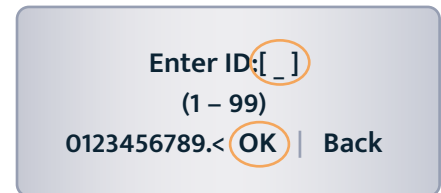

On the following screen, select **Okay** to load the configuration onto the RDC-CO(T).

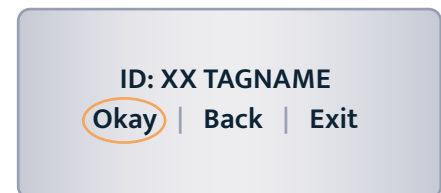

Download Data from RDC-CO(T)

On the Transfer Unit device list screen, navigate to the Legacy Converter device connected to the RDC-CO(T) to download the data from and select **DL**.

```

Devices [UP/DOWN] X
[XXXXXXXXXXXX ]
Bk=Back Sv=Save
Cfg | DL | St | Bk | Sv
  
```

On the following screen, select **RDC-COT**.

```

Select Device
RDC-COT | MDL/ML9500
RDC-CAT |
      Back | Exit
  
```

After successful data transfer, a screen will display information about the RDC-CO(T) and the latest reading.

```

ID: XXX (X) RDC-COT
Tag: XXXXXXXX
Samples XXX ( XX m/h)
      Next | Back | Exit
  
```

Use **Next** to navigate between the screens and see the Alloy, Span, Divisions and Check Readings, Temperature, Metal Loss and the time that the last data point was collected from the device.

```

Alloy: XX
Span: XX.XXX mils
      Next | Back | Exit
  
```

```

Div: XXX.X Chk: XXX.X
Temp: XXXX.X C
MLoss: X.XXX mils
      Next | Back | Exit
  
```

```

Time Stamp:
MM/DD/YY HH:MM:SS
Interval: XX m/h
      Back | Exit
  
```

Read RDC-CO(T) Status

On the Transfer Unit device list screen, navigate to the Legacy Converter device connected to the RDC and select St.

Devices [UP/DOWN] X
[XXXXXXXXXX]
Bk=Back Sv=Save
Cfg | DI | **St** | Bk | Sv

On the following screen, select **RDC-COT**.

Select Device
RDC-COT | MDL/ML9500
RDC-CAT |
Back | Exit

The Transfer Unit will connect to the RDC-CO(T) then show information about the RDC-CO(T) including the Revision, ID, Tag name, Number of Samples and Interval in which the Samples are being taken. Select **Next** to see the time of the last reading and the time that the next reading will be taken.

Revision: X
ID: XXX TAGNAME
Samples: XX (X m/h)
Next | Back | Exit

Last Read:
MM/DD/YY HH:MM:SS
Next Read: HH:MM:SS
Back | Exit

RDC CA(T)

To use the Transfer Unit with the RDC-CA(T), a Legacy Converter must be connected to the RDC-CA(T)'s service port to allow for communication between devices.

Create an ID for RDC-CA(T)

On the Transfer Unit standby screen select **Config**. On the next display screen, select **LPR** to get to a list of Corratel devices.

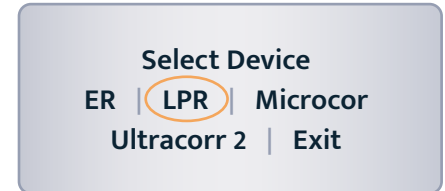

Select **RDC** from the list of devices.

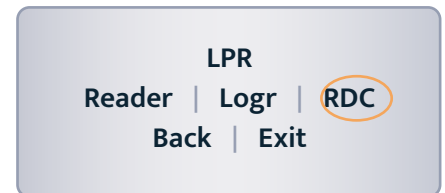

Enter the desired ID number then select **OK**.

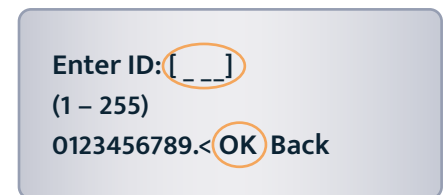

Enter the interval then select **m** for minutes or **h** for hours.

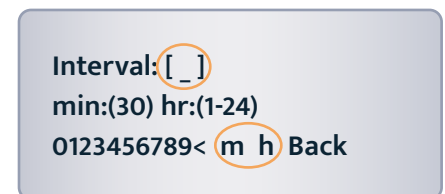

Enter a tag name for the device then select **Nxt**.

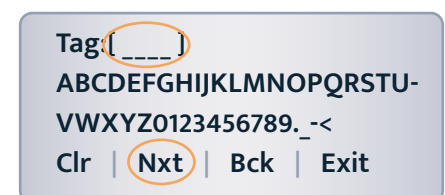

Create an ID for RDC-CA(T) (continued)

Select an alloy by using the up and down arrows to scroll through the choices then select **Next**.

```

Select Alloy
XXXXXXXXXXXXXXXX
XXXXXX (scroll U/D)
Next | Back | Exit
  
```

If **Other** is selected, the name of the alloy and the multiplier (mult) will have to be inputted manually.

```

Alloy: [ _ ]
ABCDEFGHIJKLMNQPQR
STUVWXYZ0123456789. -<
Clr | Nxt | Bck | Exit
  
```

```

Mult:< >

0123456789.< OK Back
  
```

Select either **Stdrd-E** or **Flush-F** for the probe type.

```

Select Probe Type
Stdrd-E | Flush-F
Back | Exit
  
```

Select if the probe is a temperature probe or not by selecting either **Yes** or **No**.

```

Is it a Temp. Probe?
Yes | No | Bck | Exit
  
```

To save the configuration of the device select **Okay**.

```

Save?
ID: XX TAGNAME
Okay | Back | Exit
  
```

Load Configuration onto RDC-CA(T)

To load a configuration onto the RDC-CO(T) an ID must be created. If the user has not already created an ID, please refer to the **Create an ID for RDC-CA(T)** section.

On the device list screen, find the Legacy Converter device by pushing the up and down keys and select **Cfg**.

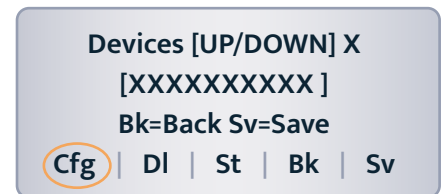

On the following screen, select **RDC-CAT**.

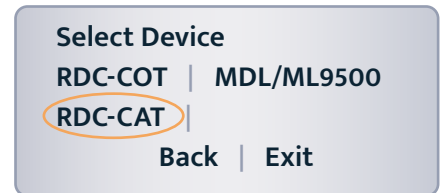

Enter the ID of the configuration to load onto the RDC-CA(T) then select **OK**.

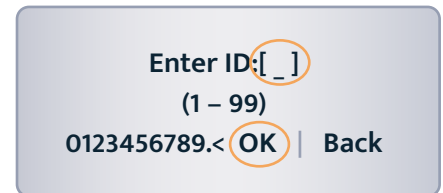

On the following screen, select **Okay** to load the configuration onto the RDC-CA(T).

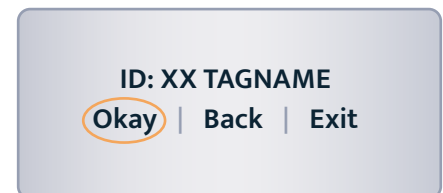

Download Data from RDC-CA(T)

On the Transfer Unit device list screen, navigate to the Legacy Converter device connected to the RDC-CA(T) to download the data from and select **DI**.

```

Devices [UP/DOWN] X
[XXXXXXXXXXXX]
Bk=Back Sv=Save
Cfg | DI | St | Bk | Sv
  
```

On the following screen, select **RDC-CAT**.

```

Select Device
RDC-COT | MDL/ML9500
RDC-CAT |
Back | Exit
  
```

After successful data transfer, a screen will display information about the RDC-CA(T) and the latest reading.

```

ID: XXX (X) RDC-CAT
Tag: XXXXXXXX
Samples XXX ( XX m/h)
Next | Back | Exit
  
```

Select **Next** to navigate between the following screens to see the Alloy, Multiplier, Cycle Time Rate, Imbalance, Temperature, the time stamp of when the last data point was taken and the interval in which the samples are being taken.

```

Alloy: XXXXXXXX
Multiplier: XX.XXX
Cycle Time: N/A
Next | Back | Exit
  
```

```

Rate: XXX mpy
Imb: XX.XXX
Temp: XXX C/F
Next | Back | Exit
  
```

```

Time Stamp:
MM/DD/YY HH:MM:SS
Interval: XX m/h
Back | Exit
  
```

Get Status of RDC-CA(T)

On the Transfer Unit device list screen, navigate to the Legacy Converter device connected to the RDC-CA(T) to download the data from and select **Stat**.

Devices
<XXXXXXXXXX >
Scroll up and down
Cfg | DL | Stat | Back

On the following screen, select **RDC-CAT**.

Select Device
RDC-COT | MDL/ML9500
RDC-CAT |
Back | Exit

Once the Transfer Unit has connected to the RDC-CA(T) it will show a screen with the Revision, ID, Tag Name, Number of Samples collected and the interval in which the samples are taken for the RDC. Select **Next** to see when the last reading was taken and when the next reading will be taken.

Revision: X
ID: XXX TAGNAME
Samples XX (X m/h)
Next | Back | Exit

Last Read:
MM/DD/YY HH:MM:SS
Next read: HH:MM:SS
Back | Exit

Microcor Datalogger/ML-9500B

To use the Transfer Unit with the Microcor Datalogger/ML-9500B, a Legacy Converter must be connected to the Microcor Datalogger/ML-9500B serial port to allow for communication between devices..

Create an ID for a Microcor Device

On the Transfer Unit standby screen select **Config**. On the next display screen, select **uCorr** to get to a list of Microcor devices.

Select Device
ER | LPR | Microcor
Ultracorr 2 | Exit

Select the type of Microcor Device.

- **MDL** (Microcor Datalogger) – MWT-3905-MDL
- **ML95** (Legacy Microcor Datalogger) – ML-9500B

Microcor
M-200 | MDL | ML95
Back | Exit

Enter the desired **ID** number then select **OK**.

Enter ID: [_ _]
(1 – 99)
0123456789.< OK Back

Enter the interval then select **m** for minutes.

Note: the hours (**h**) option is disabled and will show **INVAL** if selected.

Interval: [_]
min:(5 – 1440)
0123456789< m h Back

Enter a tag name for the device then select **Nxt**.

Tag: [_ _ _]
ABCDEFGHIJKLMNQRSTU-
VWXYZ0123456789._-<
Clr | Nxt | Bck | Exit

To save the configuration of the device select **Okay**.

Save?
ID: XX TAGNAME
Okay | Back | Exit

Load ID onto Microcor Datalogger and ML-9500B

To load a configuration onto the MDL/ML9500 a configuration must be created. If the user has not already created a configuration, please refer to the **Create an ID for a Microcor Device** section.

Scroll through the list of devices on the Transfer Unit until the **BT Wireless** name of the desired Legacy Converter is displayed and then select **Cfg**.

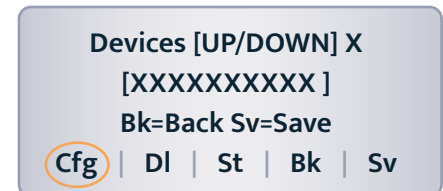

On the following screen, select **MDL/ML9500**.

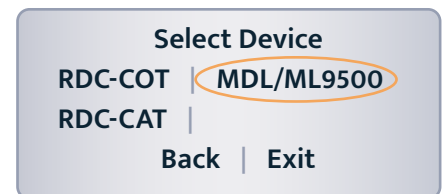

Enter the **ID** of the configuration to load onto the Datalogger then select **OK**.

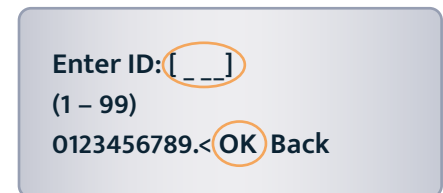

On the following screen, select **Okay** to load the configuration onto the Datalogger.

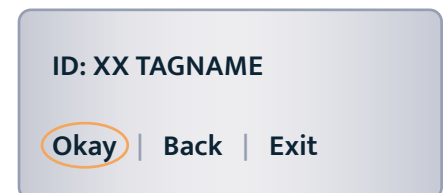

Download Data from Microcor Datalogger and ML-9500B

On the Transfer Unit device list, navigate to the Legacy Converter connected to the Microcor Datalogger or ML-9500B and select DI.

```

Devices [UP/DOWN] X
[XXXXXXXXXXXX ]
Bk=Back Sv=Save
Cfg | DI | St | Bk | Sv
  
```

On the following screen, select **MDL/ML9500**.

```

Select Device
RDC-COT | MDL/ML9500
RDC-CAT |
Back | Exit
  
```

After a successful data transfer, a screen will appear with information about the MDL/ML-9500B including its ID, Tag Name, the number of samples downloaded and the interval in which data is collected.

```

ID:XX MDL
Tag: TAGNAME
Samples: XXXX (XX m)
Next | Back | Exit
  
```

```

ID:XX ML9500
Tag: TAGNAME
Samples: XXXX (XX m)
Next | Back | Exit
  
```

Select **Next** to continue to the next display which shows Probe Life Units (PLU).

```

PLU: XXXXX
Next | Back | Exit
  
```

Select **Next** to continue to the next display to see the time when the last data point was collected as well as what intervals the data is being taken at.

```

Time Stamp:
MM/DD/YY HH:MM:SS
Interval: (XX m)
Back | Exit
  
```

Read Microcor Datalogger/ML-9500B Status

On the Transfer Unit device list, navigate to the Legacy Converter device connected to the Microcor Datalogger or ML-9500B and select **St**.

```

Devices [UP/DOWN] X
[XXXXXXXXXXXX]
Bk=Back Sv=Save
Cfg | DI | St | Bk | Sv
  
```

On the following screen, select **MDL/ML9500**.

```

Select Device
RDC-COT | MDL/ML9500
RDC-CAT |
Back | Exit
  
```

After a successful data transfer, the following screen will appear with the attached information. Select **Next** to continue to the next display which shows the current time on the MDL.

```

ID:XX TAGNAME
Samples: XXXX
Interval: XX m/h
Next | Back | Exit
  
```

```

Current Time:
MM/DD/YY HH:MM:SS
Next | Back | Exit
  
```

Select **Next** to continue to the next display which shows the battery, memory and transmitter information as shown below. Battery status will show good or low. Memory and transmitter will show good or bad depending on their status.

```

Battery: Good/Low
Memory: Good/Bad
Transmitter: Good/Bad
Back | Exit
  
```

Chapter 8

ER Datalogger

Create an ID for ER Datalogger

On the Transfer Unit standby screen select **Config**. On the next display screen, select **ER** to get to a list of Corrosometer devices.

Select Device
 ER | LPR | Microcor
 Ultracorr 2 | Exit

Select **Logr** from the list of devices.

ER
 Reader | Logr | RDC
 Back | Exit

Enter the desired ID number then select **OK**.

Enter ID:[_]
 (1 - 255)
 0123456789.< OK | Back

Enter the interval then select **m** for minutes or **h** for hours.

Interval:[_]
 min:(5-59) hr:(1-24)
 0123456789.< m h Back

Enter a tag name for the device then select **Nxt**.

Tag:[_]
 ABCDEFGHIJKLMNOPQRSTU-
 VWXYZ0123456789._-<
 Clr | Nxt | Bck | Exit

Enter in the name of the alloy then select **Nxt**.

Alloy:[_ _ _ _ _]
 ABCDEFGHIJKLMNOPQR
 STUVWXYZ0123456789._-<
 Clr | Nxt | Bck | Exit

Note: The name of the alloy is for reference only and does not affect the calculation of corrosion rates.

Create an ID for ER Datalogger (continued)

Select the probe type used with the ER Datalogger then select **Next**.

Select Probe Type
< XX XXXXXXXXXXX X >
Scroll up and down
Next | Back | Exit

If the user selects any of the Other probe options, the following screen will appear. Manually enter the span of the probe.

Span:< > mils
0123456789.< OK Back

Select if the probe is a temperature probe or not by selecting either **Yes** or **No**.

Is it a Temp. Probe?
Yes | **No** | Bck | Exit

To save the configuration of the device select **Okay**.

Save?
ID: XX TAGNAME
Okay | Back | Exit

Load Configuration onto ER Datalogger

To load a configuration onto the ER Datalogger an ID must be created. If the user has not already created an ID, please refer to the **Create an ID for ER Datalogger** section.

On the device list screen, find the ER Datalogger device by pushing the up and down keys and select **Cfg**.

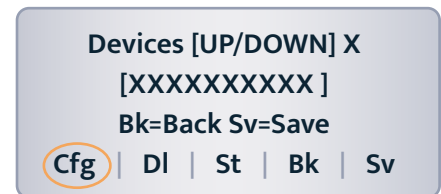

Enter the ID of the configuration to load onto the ER Datalogger then select **OK**.

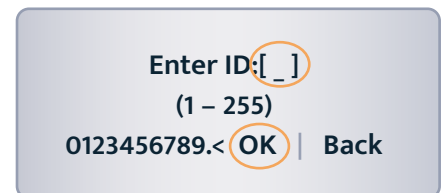

Select **Okay** to load the configuration onto the ER Datalogger.

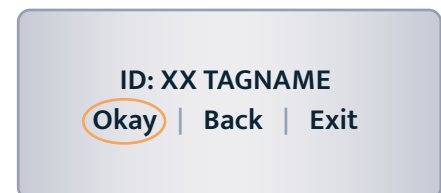

Download Data from ER Datalogger

On the Transfer Unit device list, navigate to the ER Datalogger device and select **DI**.

```

Devices [UP/DOWN] X
[XXXXXXXXXX ]
Bk=Back Sv=Save
Cfg | DI | St | Bk | Sv
  
```

After successful data transfer, a screen will display information about the ER Datalogger and the latest reading.

```

ID: XXX (X) RDC-COT
Tag: XXXXXXXX
Samples XXX ( XX m/h)
Next | Back | Exit
  
```

Use **Next** to navigate between the screens and see the Alloy, Span, Divisions and Check Readings, Temperature, Metal Loss and the time that the last data point was collected from the device.

```

Alloy: XX
Span: XX.XXX mils
Next | Back | Exit
  
```

```

Div: XXX.X Chk: XXX.X
Temp: XXXX.X C
MLoss: X.XXX mils
Next | Back | Exit
  
```

```

Time Stamp:
MM/DD/YY HH:MM:SS
Interval: XX m/h
Back | Exit
  
```

Get Status of ER Datalogger

On the Transfer Unit device list screen, navigate to the ER Datalogger device and select **St**.

```
Devices [UP/DOWN] X
[XXXXXXXXXX ]
Bk=Back Sv=Save
Cfg | DI | St | Bk | Sv
```

The Transfer Unit will connect to the ER Datalogger then show information about the ER Datalogger including the Revision, ID, Tag name, Number of Samples and Interval in which the Samples are being taken. Select **Next** to see the time of the last reading and the time that the next reading will be taken.

```
Revision: X
ID: XXX TAGNAME
Samples: XX ( X m/h)
Next | Back | Exit
```

```
Last Read:
MM/DD/YY HH:MM:SS
Next Read: HH:MM:SS
Back | Exit
```

Chapter 9

LPR Datalogger

Create an ID for LPR Datalogger

On the Transfer Unit standby screen select **Config**. On the next display screen, select **LPR** to get to a list of Corrosometer devices.

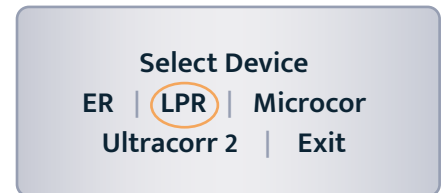

Select **RDC2** from the list of devices.

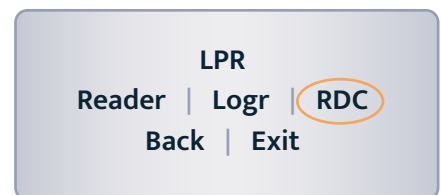

Enter the desired ID number then select **OK**.

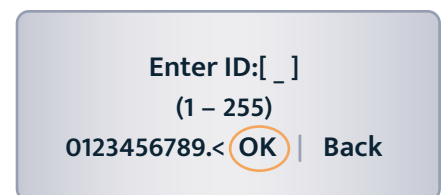

Enter the interval then select **m** for minutes or **h** for hours.

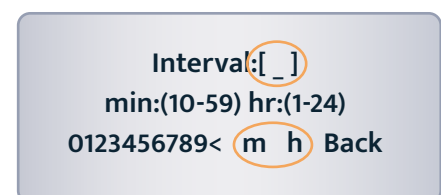

Enter a tag name for the device then select **Nxt**.

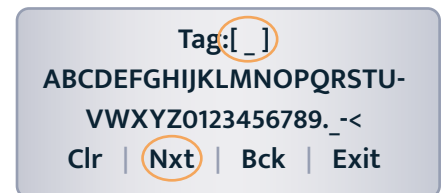

Select an alloy by using the up and down arrows to scroll through the choices then select **Nxt**.

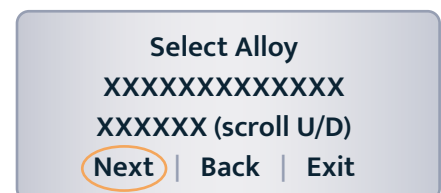

Create an ID for LPR Datalogger (continued)

If **Other** is selected, the name of the alloy and the multiplier (mult) will have to be inputted manually.

Alloy: [_]
 ABCDEFGHIJKLMNOPQR
 STUVWXYZ0123456789. _-<
 Clr | Nxt | Bck | Exit

Mult:< >
 0123456789.< OK Back

Select either **Stdrd-E** or **Flush-F** for the probe type.

Select Probe Type
 Stdrd-E | Flush-F
 Back | Exit

Select the cycle time for the device by selecting either **Min** or **Auto**.

Select Cycle Time
 in Minutes
 Min | Auto | Back

Select if the probe is a temperature probe or not by selecting either **Yes** or **No**.

Is it a Temp. Probe?
 Yes | No | Bck | Exit

To save the configuration of the device select **Okay**.

Save?
 ID: XX TAGNAME
 Okay | Back | Exit

Load Configuration onto LR Datalogger

To load a configuration onto the ER Datalogger an ID must be created. If the user has not already created an ID, please refer to the **Create an ID for LPR Datalogger** section.

On the device list screen, find the LPR Datalogger device by pushing the up and down keys and select **Cfg**.

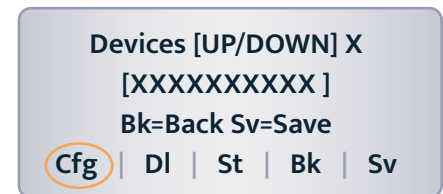

Enter the ID of the configuration to load onto the LPR Datalogger then select **OK**.

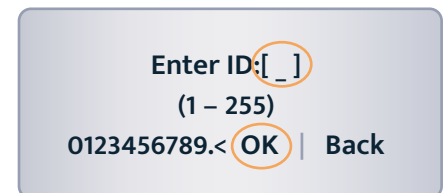

Select **Okay** to load the configuration onto the LPR Datalogger.

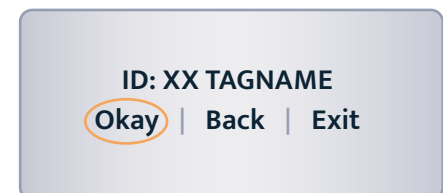

Download Data from LPR Datalogger

On the Transfer Unit device list, navigate to the LPR Datalogger device and select and select **Dl**.

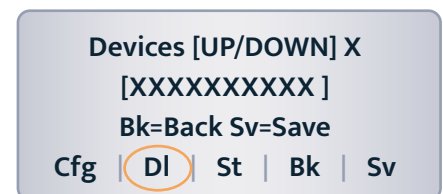

After successful data transfer, a screen will display information about the LPR Datalogger and the latest reading.

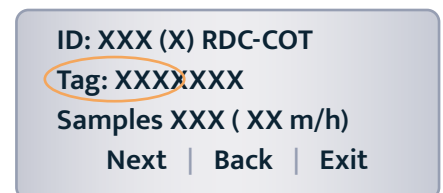

Download Data from for LPR Datalogger (continued)

Use **Next** to navigate between the screens and see the Alloy, Multiplier, Cycle Time, Rate, Imbalance, Temperature, Interval at which readings are being taken and the time that the last data point was collected from the device.

Alloy: XX
 Span: XX.XXX mils
Next | Back | Exit

Div: XXX.X Chk: XXX.X
 Temp: XXXX.X C
 MLoss: X.XXX mils
Next | Back | Exit

Time Stamp:
 MM/DD/YY HH:MM:SS
 Interval: XX m/h
 Back | Exit

Get Status of LPR Datalogger

On the Transfer Unit device list screen, navigate to the LPR Datalogger device **St**.

Devices [UP/DOWN] X
 [XXXXXXXXXXXX]
 Bk=Back Sv=Save
 Cfg | DI | **St** | Bk | Sv

The Transfer Unit will connect to the LPR Datalogger then show information about the LPR Datalogger including the Revision, ID, Tag name, Number of Samples and Interval in which the Samples are being taken. Select **Next** to see the time of the last reading and the time that the next reading will be taken.

Revision: X
 ID: XXX TAGNAME
 Samples: XX (X m/h)
Next | Back | Exit

Last Read:
 MM/DD/YY HH:MM:SS
 Next Read: HH:MM:SS
 Back | Exit

Chapter 10

Transfer Readings from the Transfer Unit to Cosasco Data

For maximum functionality and data management, all the data contained in the Transfer Unit may be downloaded to a personal computer running Cosasco Data Corrosion Management Software. The Cosasco Data software package is a flexible corrosion data management system that allows integration of all corrosion monitoring parameters. Refer to the Cosasco Data Corrosion Management Software documentation for installation, site setup, capabilities and other details.

BT Wireless Communication Requirements

In order to connect the Transfer Unit to the PC, the user will need a PC with Bluetooth capability or a Bluetooth USB Adapter, which can be ordered through Cosasco (P/N 723763). The recommended Bluetooth version is 2.1 + Enhanced Data Rate (EDR), but is compatible with Bluetooth version 2.0, 1.2 and 1.1.

Create a New Group

Run Cosasco Data and from the Devices drop down list select **Transfer Unit**. A window will pop up for the Transfer Unit Driver.

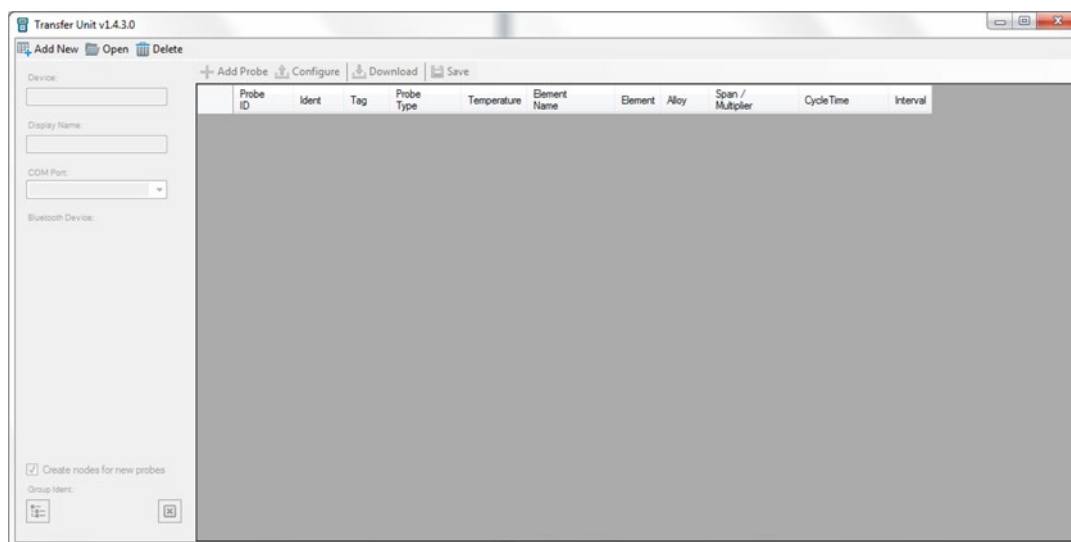

Create a New Group (continued)

In the top right corner, select **Add New** to create a new group for the Transfer Unit.

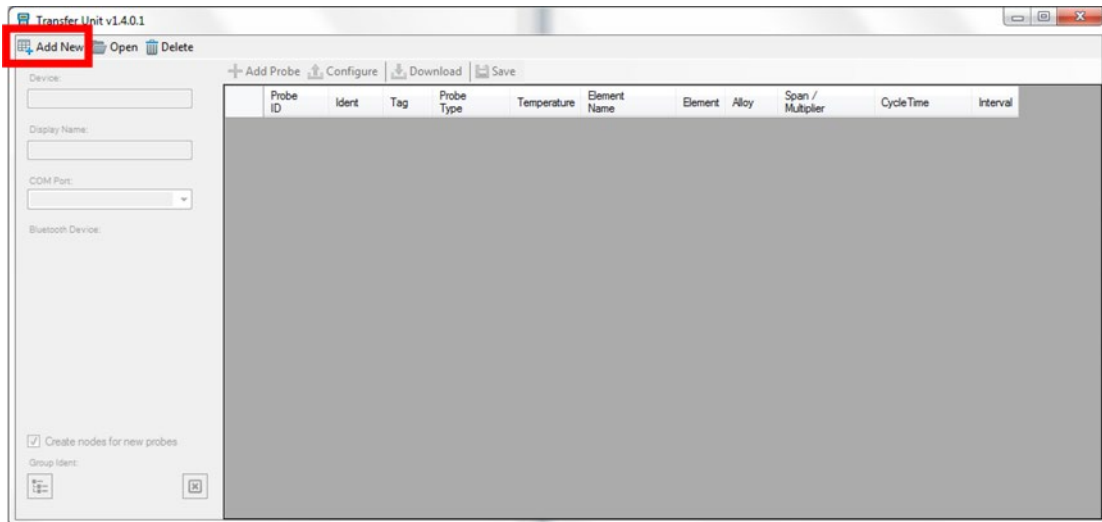

The following window will pop up. Select **Transfer Unit** and select **OK**.

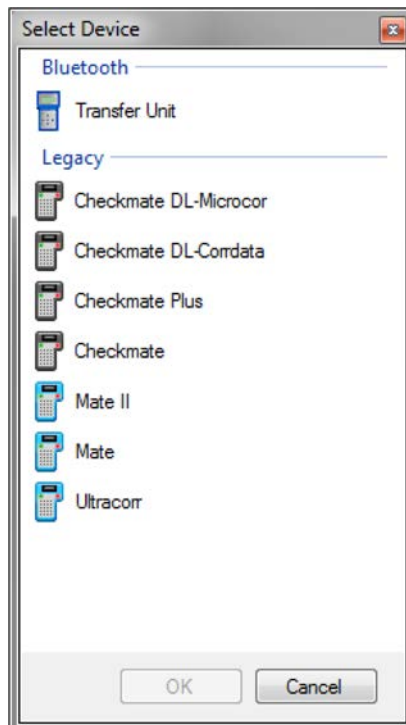

Create a New Group (continued)

After creating a new group, the Transfer Unit Driver window will now appear as below. Name the group by typing the desired name into the **Display Name** box and click **Save** to save the changes made.

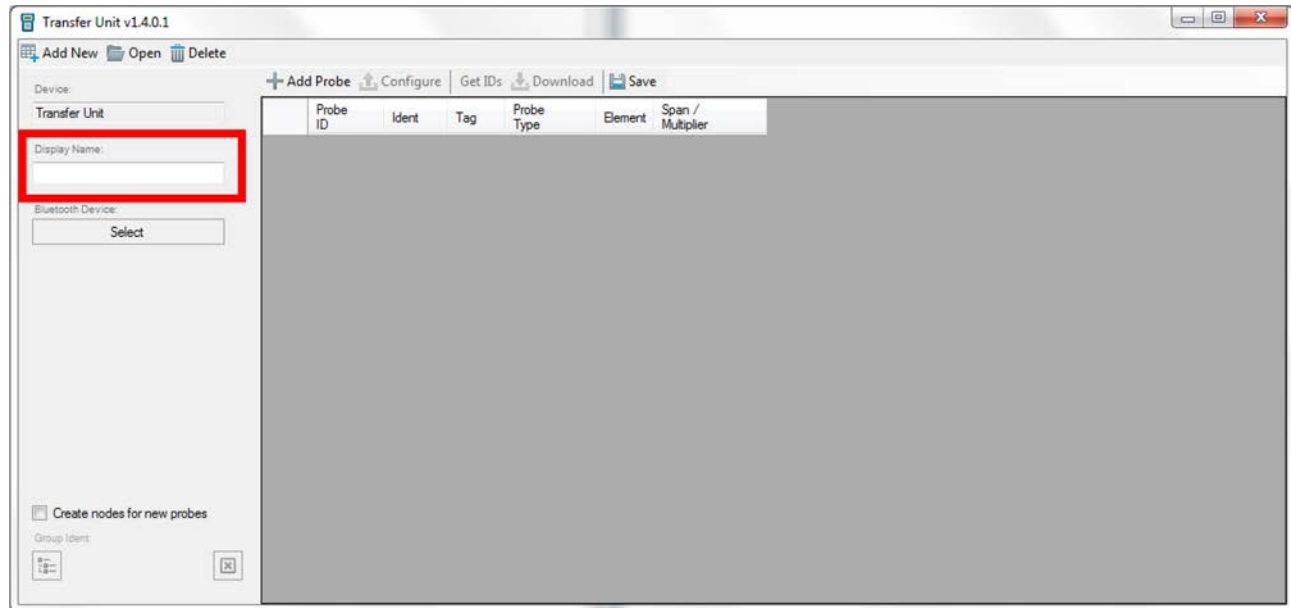

Open a Group

Run Cosasco Data and from the **Devices** drop down list select **Transfer Unit**. A window will pop up for the Transfer Unit Driver.

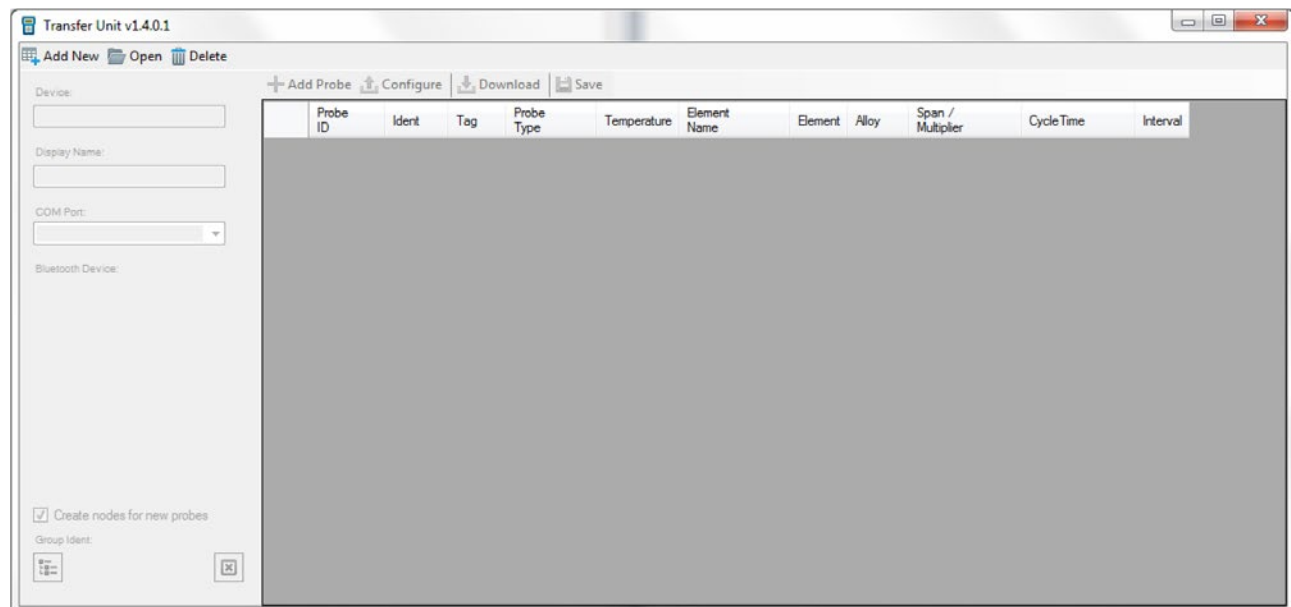

Open a Group (continued)

In the top right corner, select **Open** to open a previously created group for the Transfer Unit.

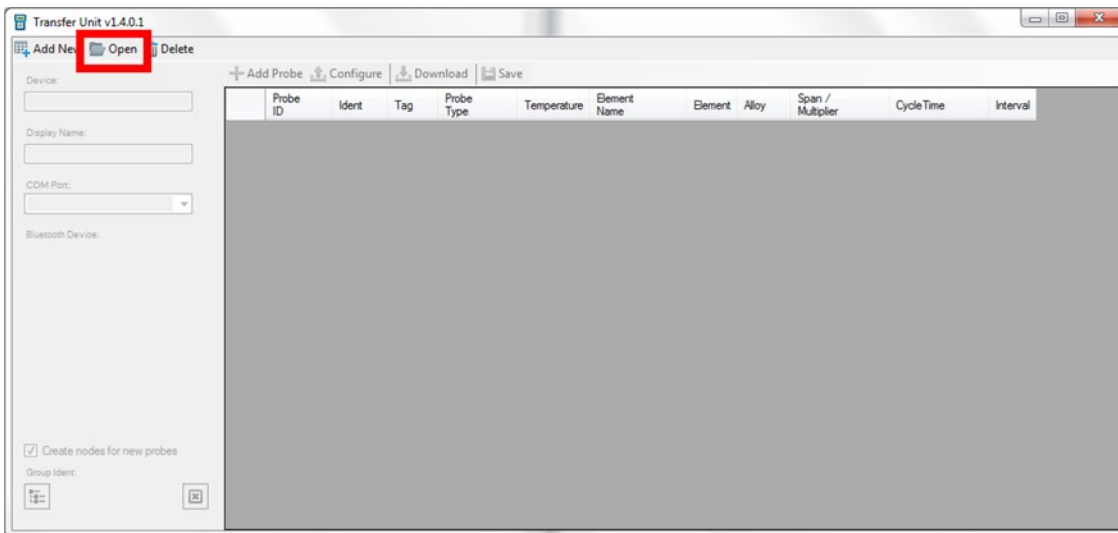

A screen will pop up containing a list of all of groups created for the Transfer Unit Driver with the group name next to the group type which is in brackets. Select the group for the **Transfer Unit** then select **OK**.

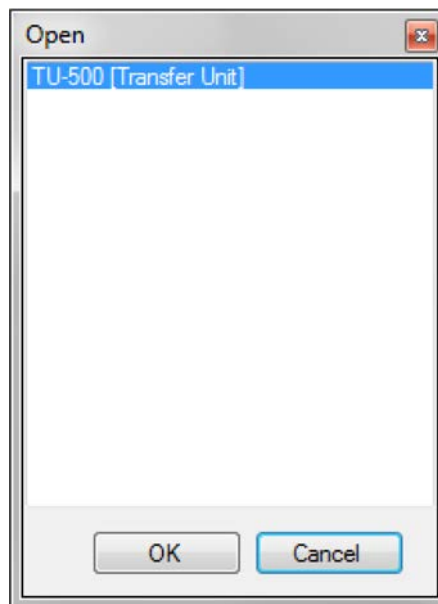

Add a Probe Through Cosasco Data

Run Cosasco Data and from the **Devices** drop down list select **Transfer Unit**. A window will pop up for the Transfer Unit Driver. After creating a new group or opening a group, select **Add Probe** to add a new probe to the list of probes for the Transfer Unit.

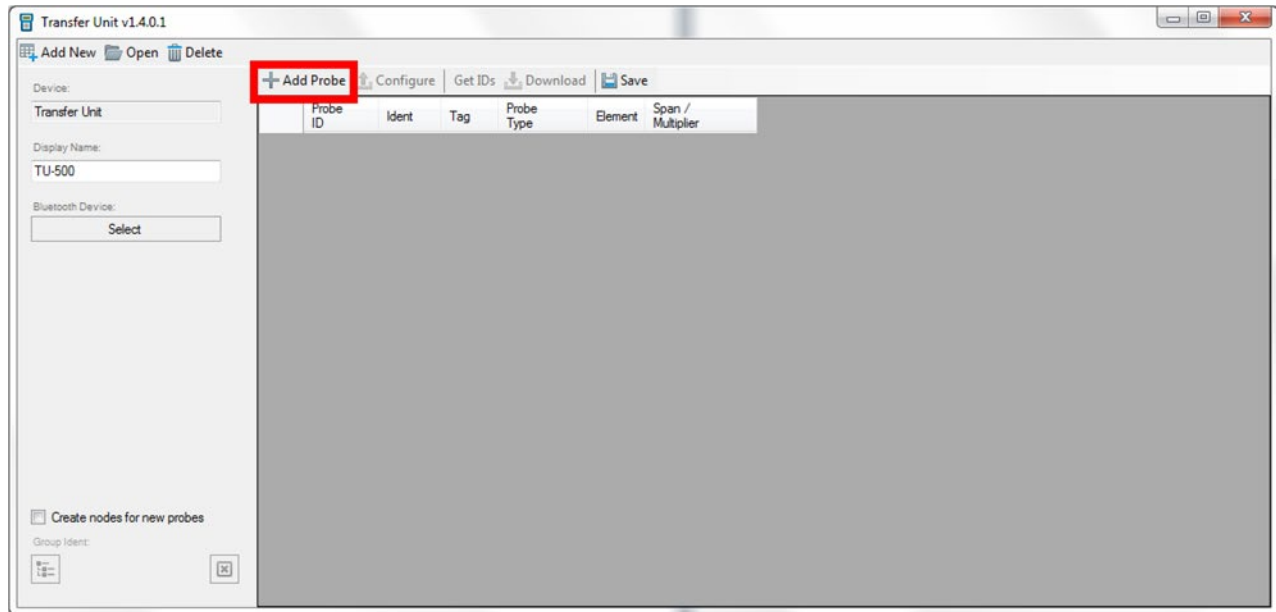

The following screen will appear. Enter the **Probe ID**, **Tag Name** and **Probe Type**. Depending on the Probe Type chosen, enter the **Element**, **Alloy**, **Span**, if it's a **Temperature Probe**, and **Interval** in which it collects data.

Probe Configuration

ID:

Tag:

Type:

Element:

Alloy:

Span (mils):

Temperature:

Interval:

Cycle Time:

Where to save data:

Ident:

Add a Probe Through Cosasco Data (continued)

Optional: Click the box next to **Ident** and select a node to store the Probe's Data to then click **OK**.

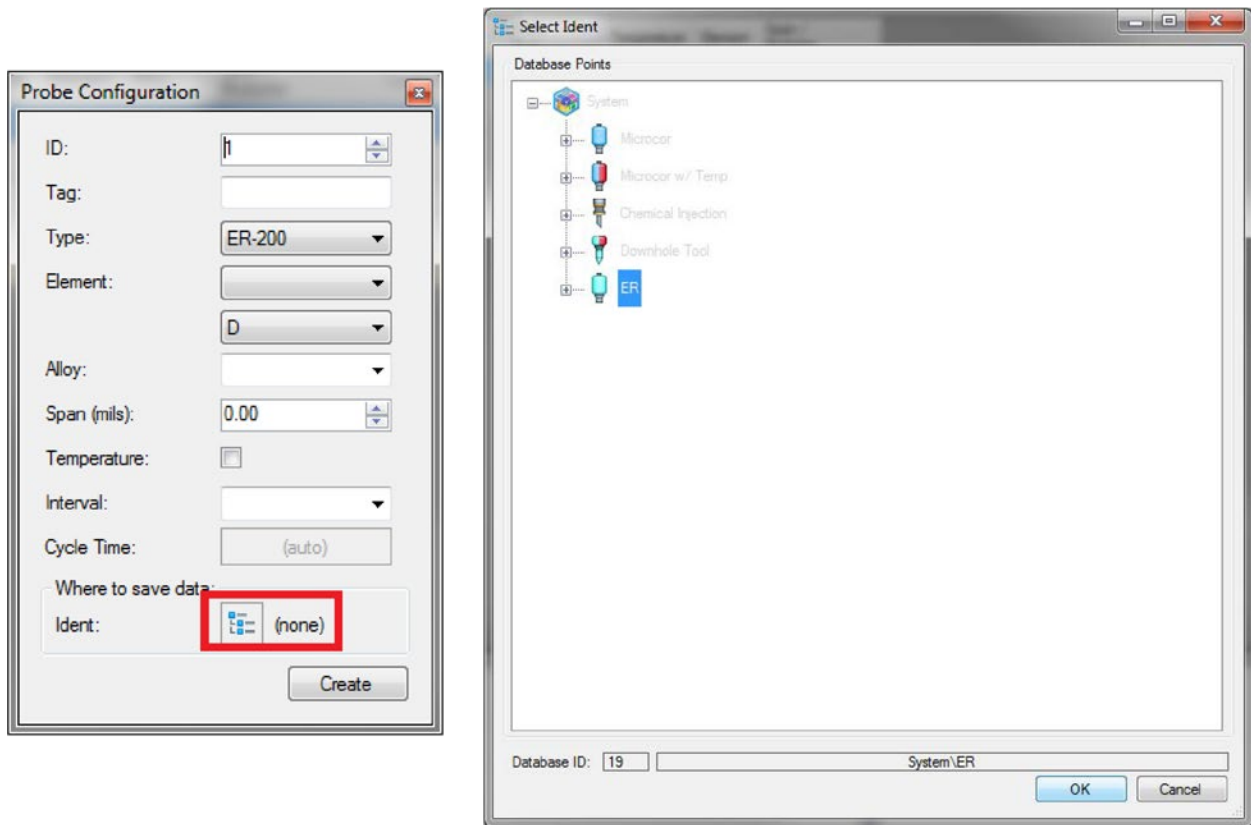

Once the user has finished entering the details of the probe, select **Create** to add the probe to the list. Then click **Save** to save the changes made to the Transfer Unit group.

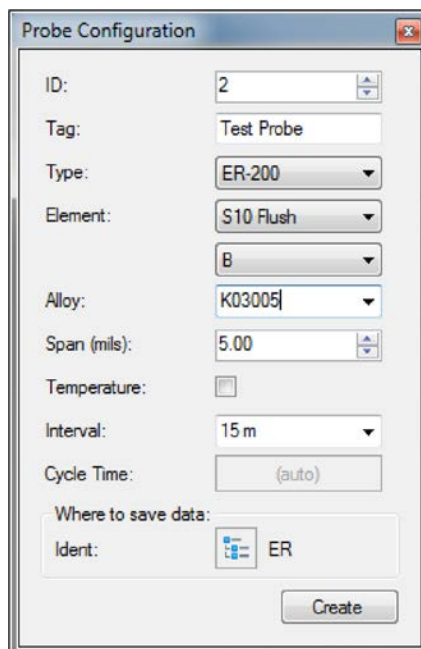

Add a Probe Through Cosasco Data (continued)

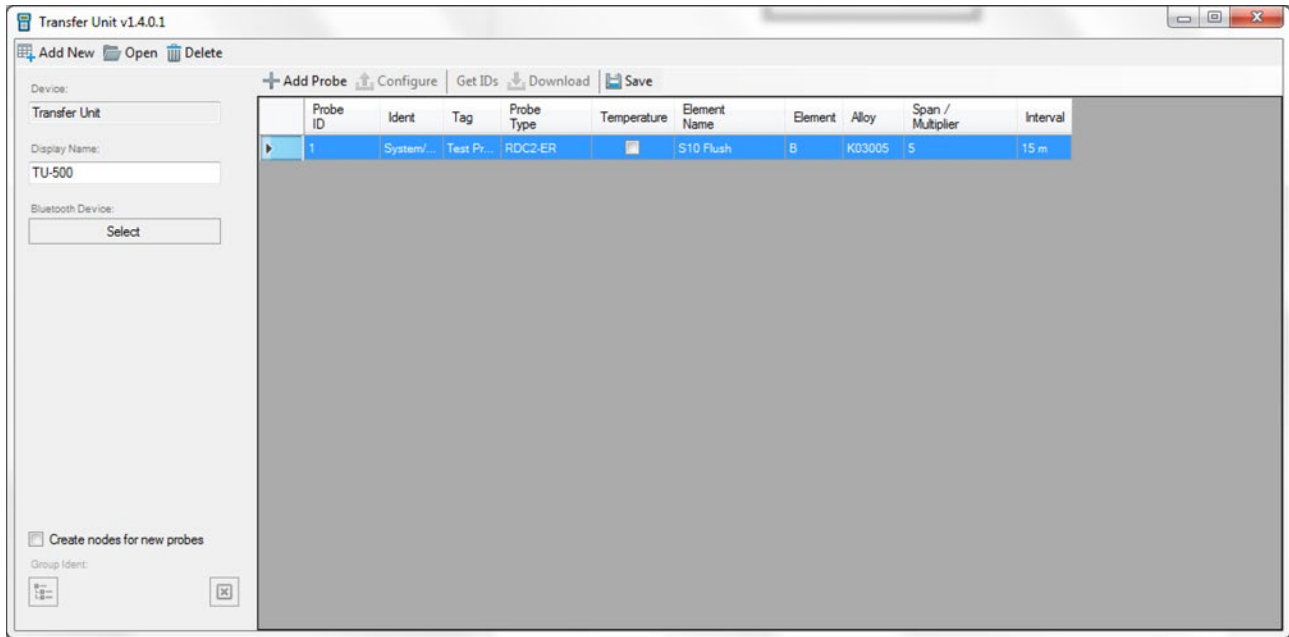

Create Nodes for New Probes (Optional)

The Transfer Unit Driver gives the user the option to create new nodes in the Plant Layout for Probe Data collected through the Transfer Unit. This removes the step of creating a node manually and choosing a node to save the Probe Data to.

On the Transfer Unit Driver screen, select the checkbox next to **Create nodes for new probes**.

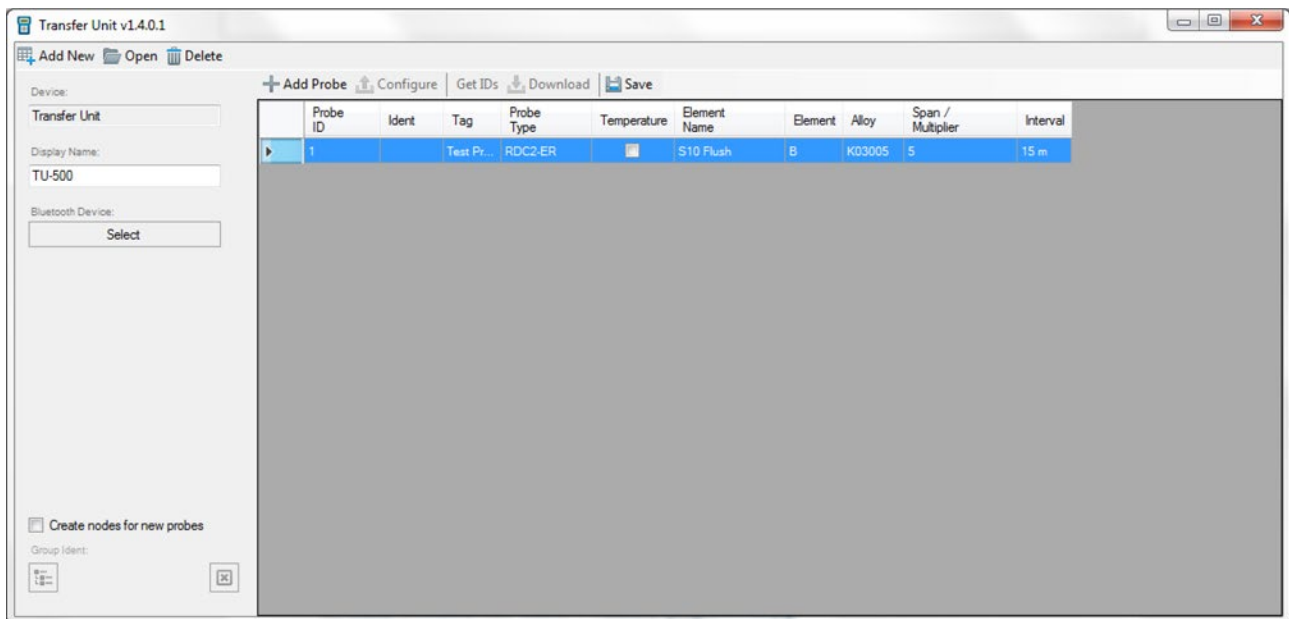

Create Nodes for New Probes (continued)

Click the icon under **Group Ident** and a window will appear with the Plant Layout within.

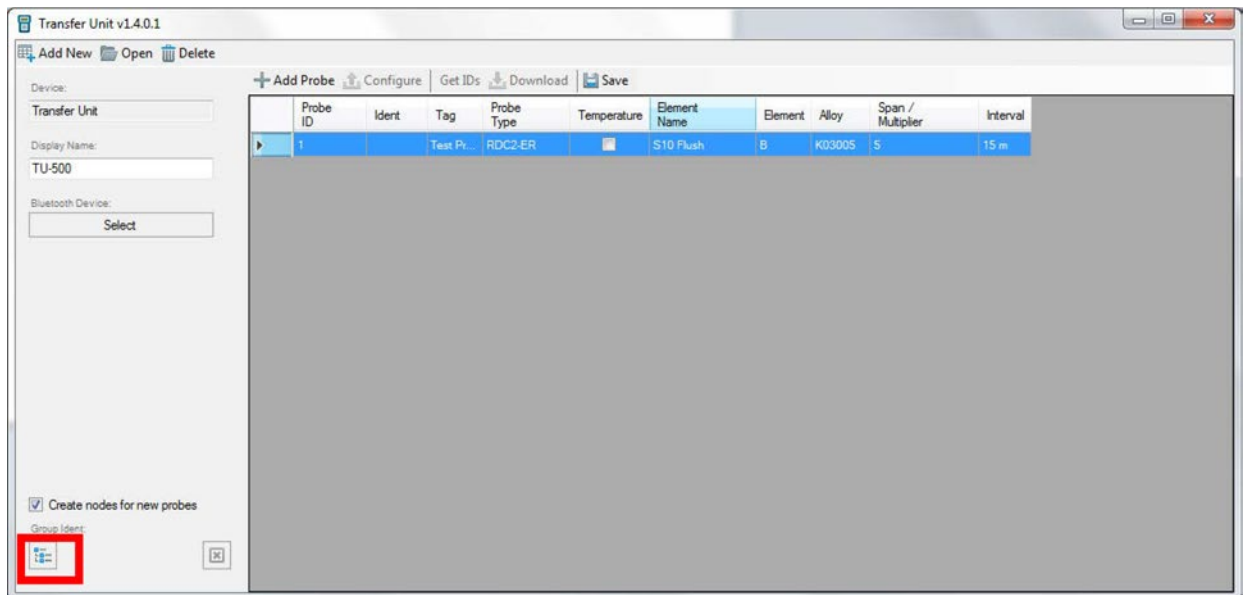

Select a **System** or **Subsystem** node for new probes to be created under and select **OK**.

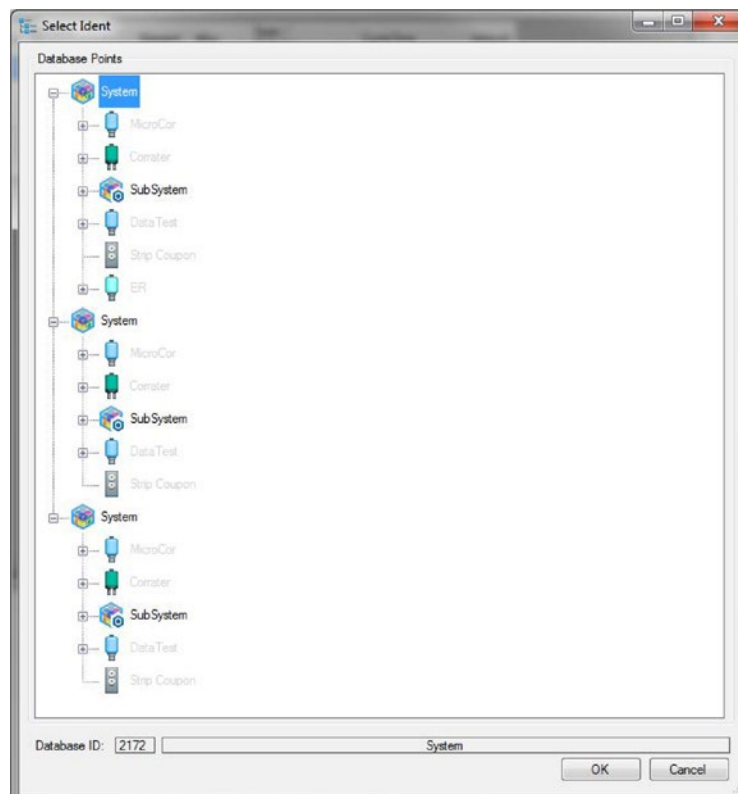

Create Nodes for New Probes (continued)

Select **Save** to save the changes to where the new probes will be stored.

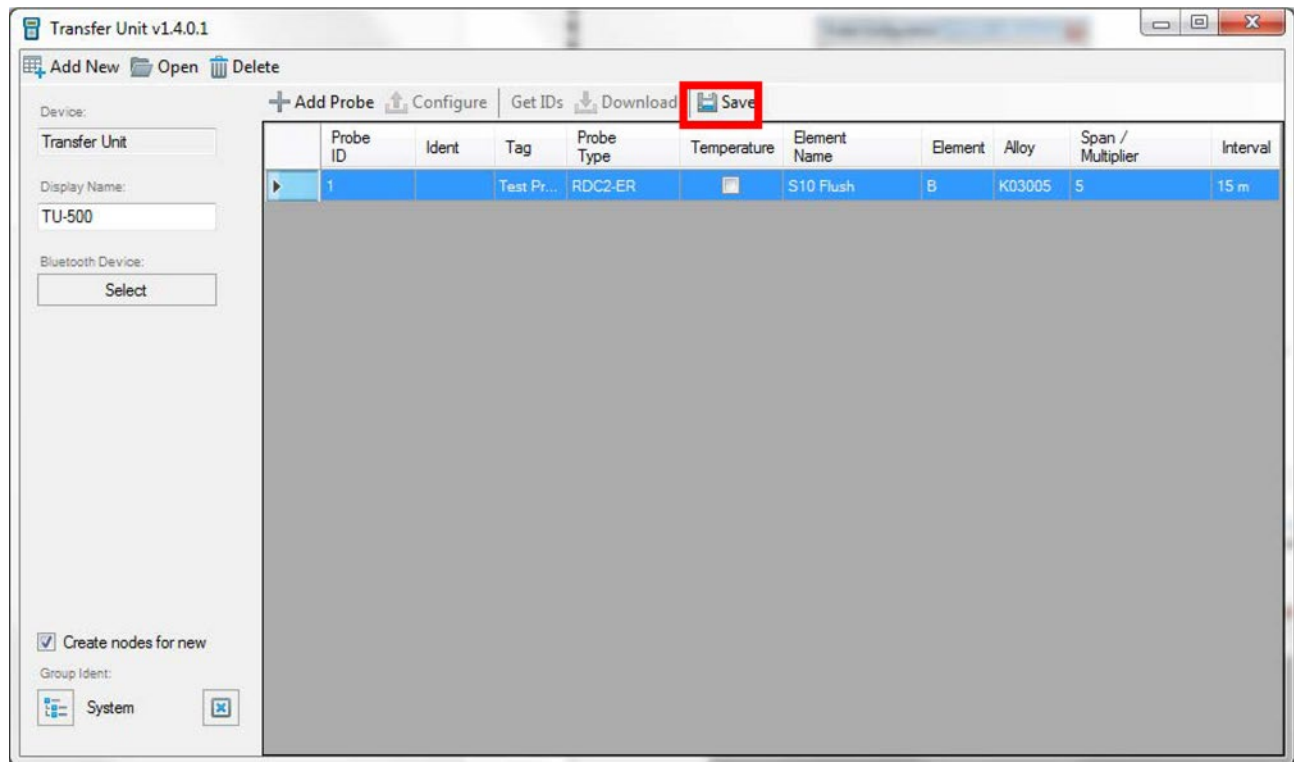

Connect Transfer Unit to PC

On the Transfer Unit select **PC** from the standby screen. It will show the following screen while waiting to connect to the PC.

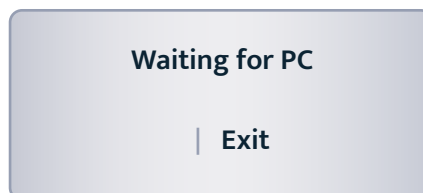

Connect Transfer Unit to PC (continued)

On the Transfer Unit Driver, click the box under **Bluetooth Device**.

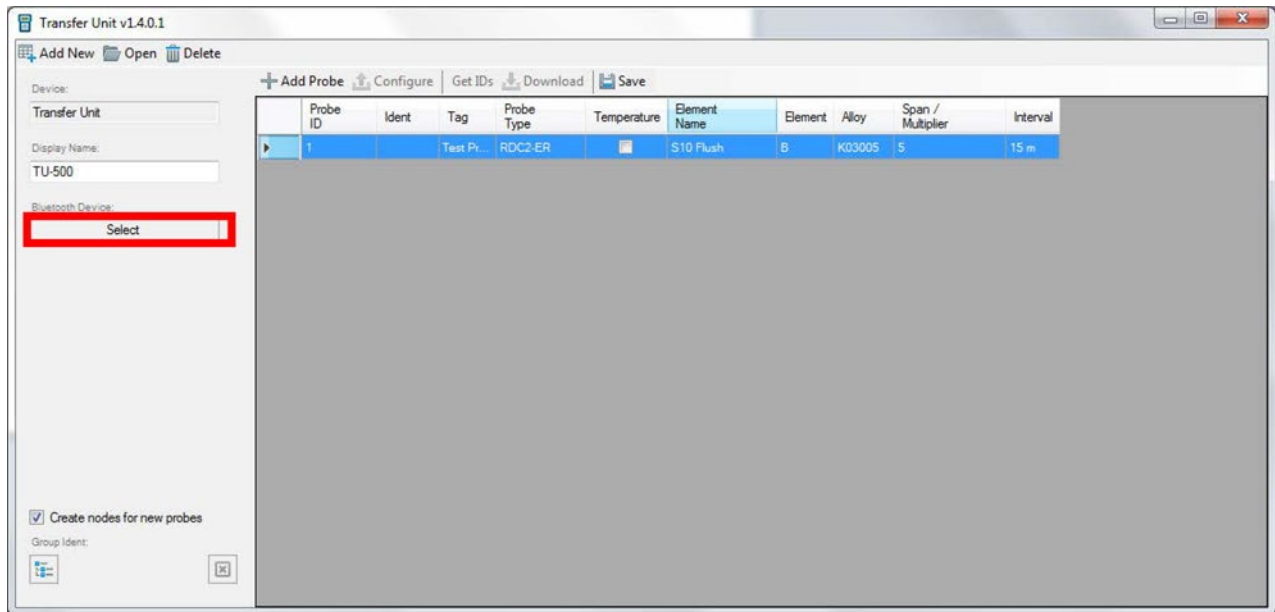

A window will appear with possible Bluetooth devices the PC can connect to. Select the Transfer Unit device then click **OK**.

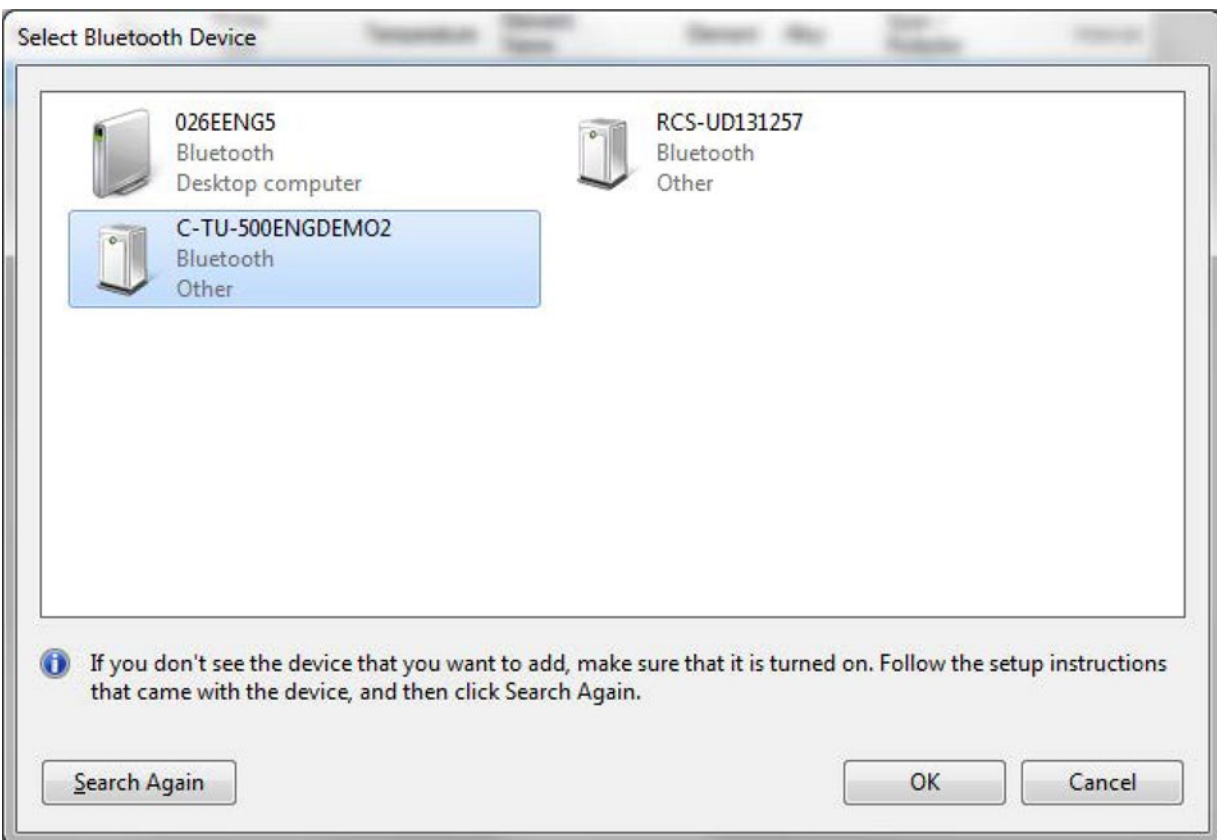

Create Nodes for New Probes (continued)

The Transfer Unit Driver will now show the name of the Transfer Unit the PC is connected to and connected in green underneath. The Transfer Unit will show the following screen.

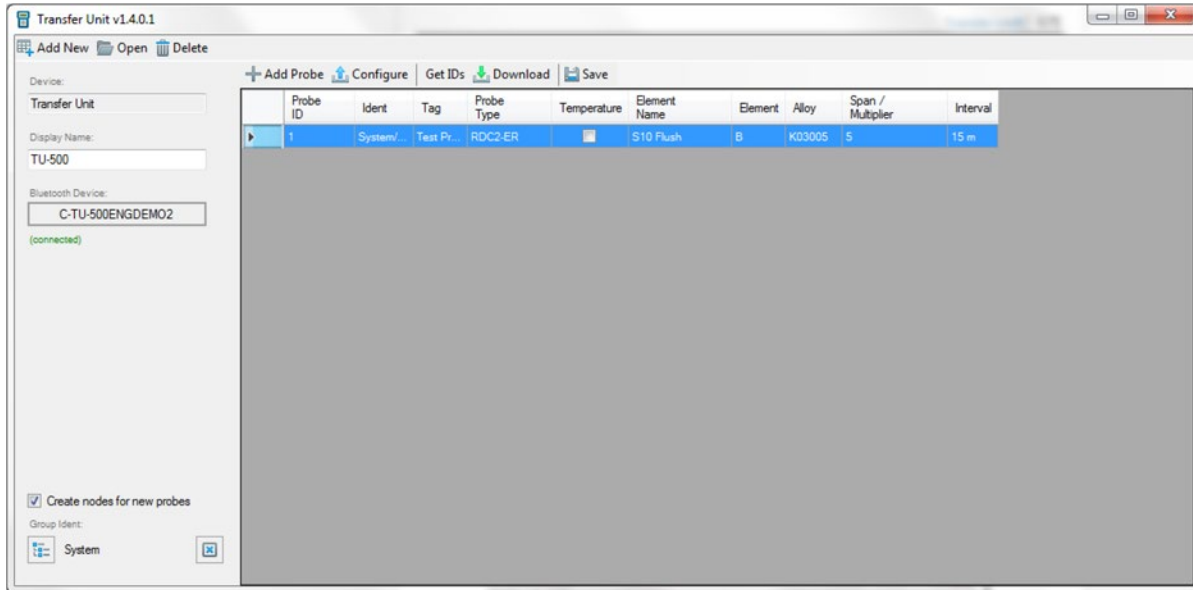

Waiting for Command

Get ID's from Transfer Unit

Once the Transfer Unit has connected to the PC, select Get IDs from the Transfer Unit Driver window.

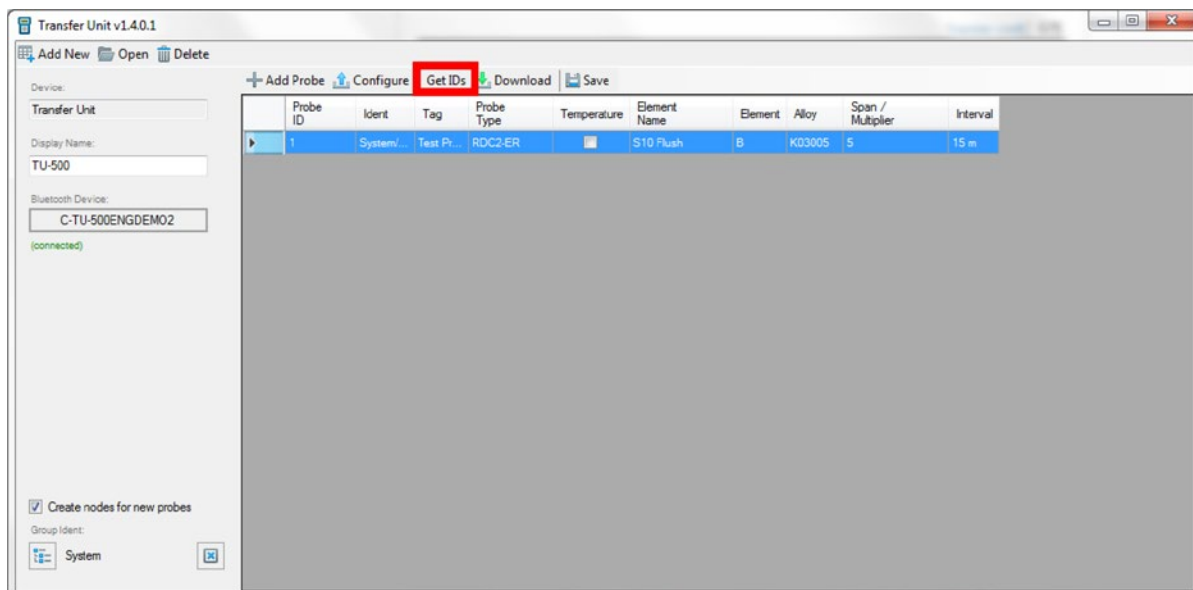

Get ID's from Transfer Unit (continued)

Once the transfer of the ID's on the Transfer Unit to the PC is complete, the user will see a list of all probes from the Transfer Unit. Click **Save** to save the list of probes from the Transfer Unit.

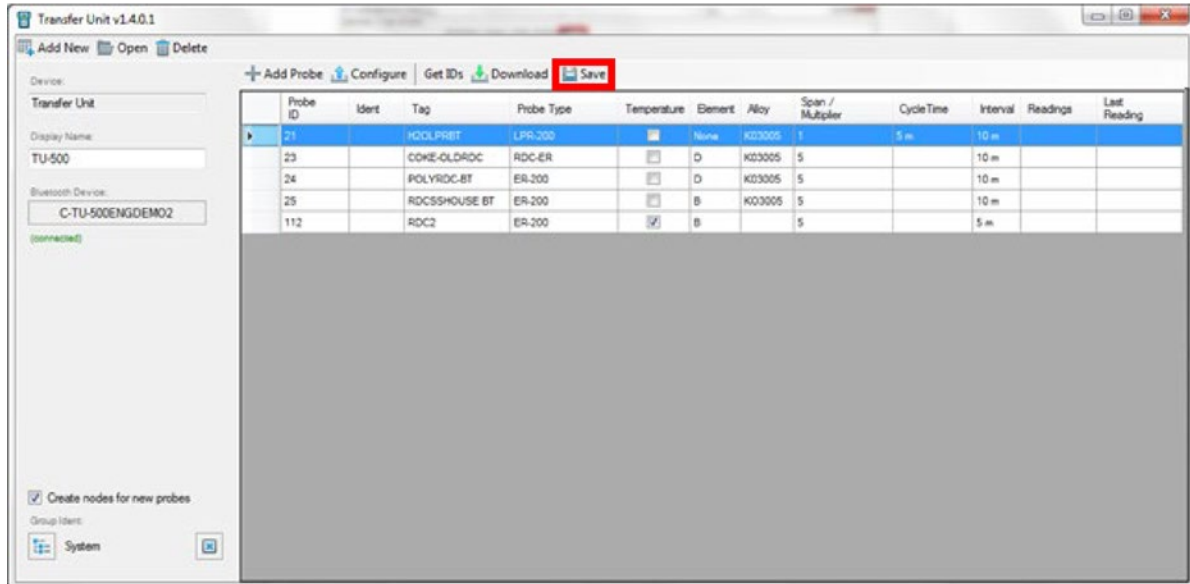

Configure Probes

Warning: Changing the configuration of the Probes through the Transfer Unit Driver will erase all stored data.

Configure Individual Probes

To change the configuration of a probe, right click it and select **Edit Details**.

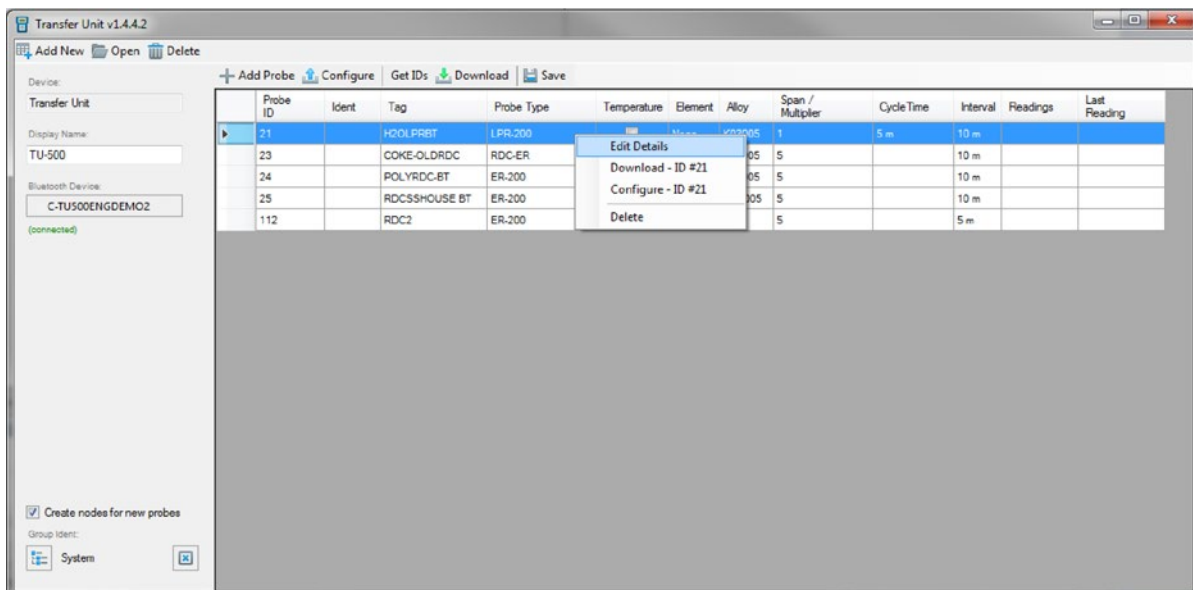

Configure Individual Probes (continued)

On the window that appears, the user can change the Probe ID, Tag Name, Element, Alloy, Span, if it's a Temperature probe, Interval and Cycle Time depending on what type of probe it is.

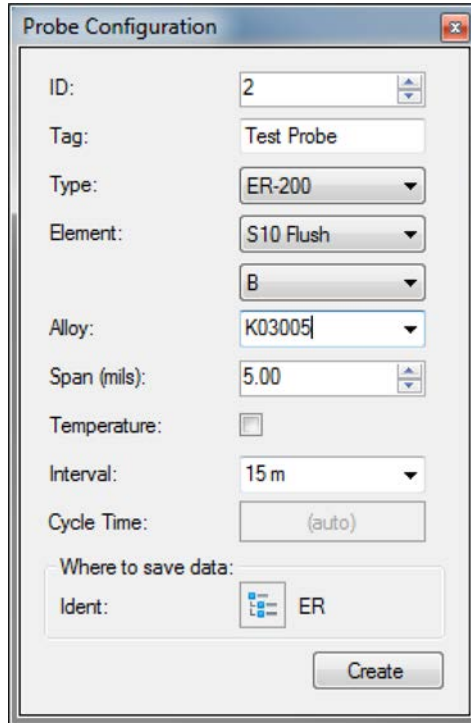

Exit out of the screen once the user has finished changing the details of the probe. Right click the probe and select **Configure – ID** to change the configuration of the probe on the Transfer Unit.

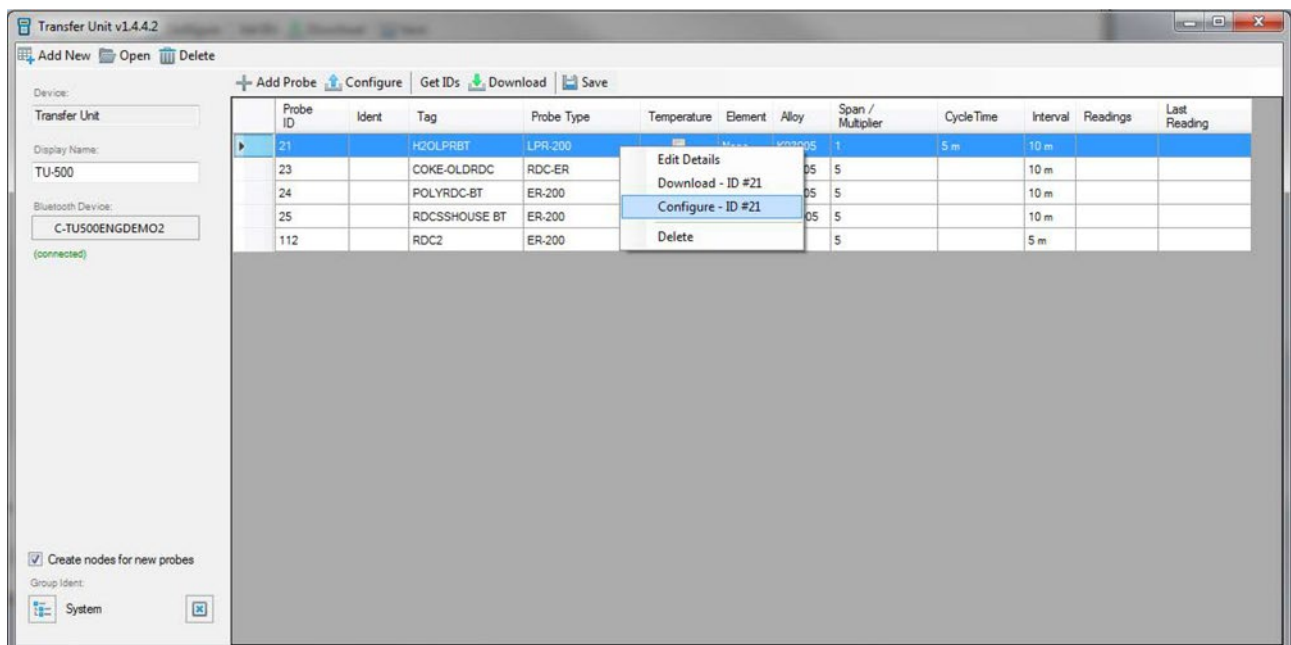

Configure All Probes

To change the configuration of a probe, right click it and select **Edit Details**.

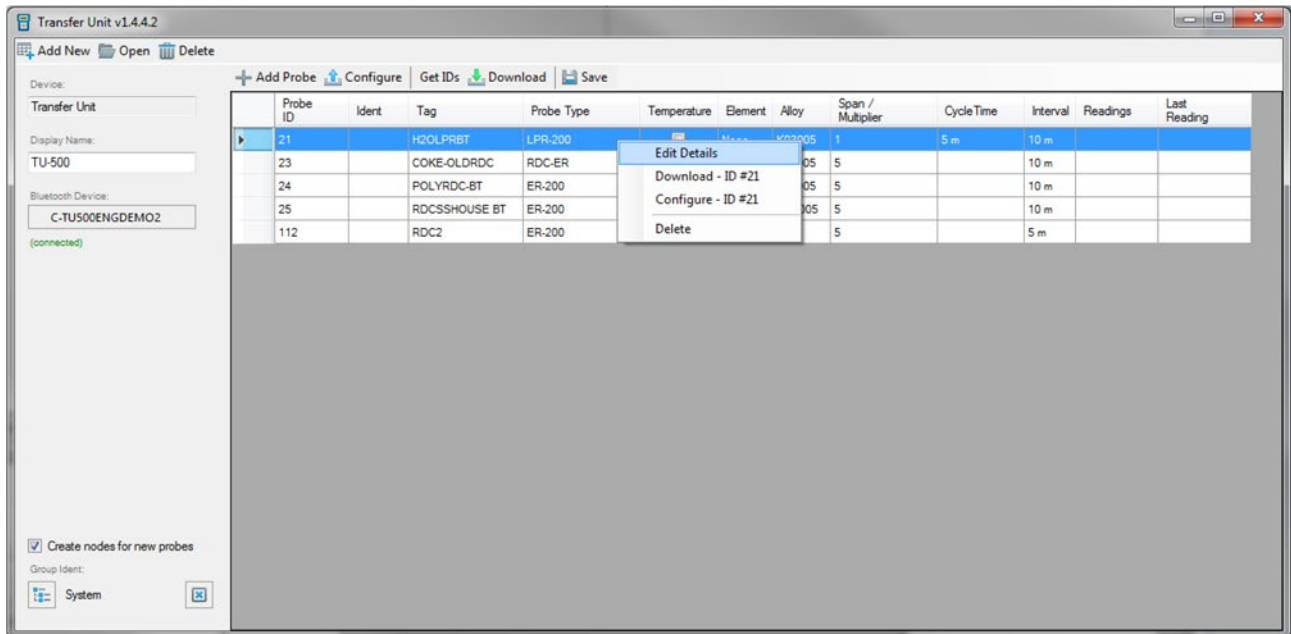

On the window that appears, the user can change the Probe ID, Tag Name, Element, Alloy, Span, if it's a Temperature probe, Interval and Cycle Time depending on what type of probe it is.

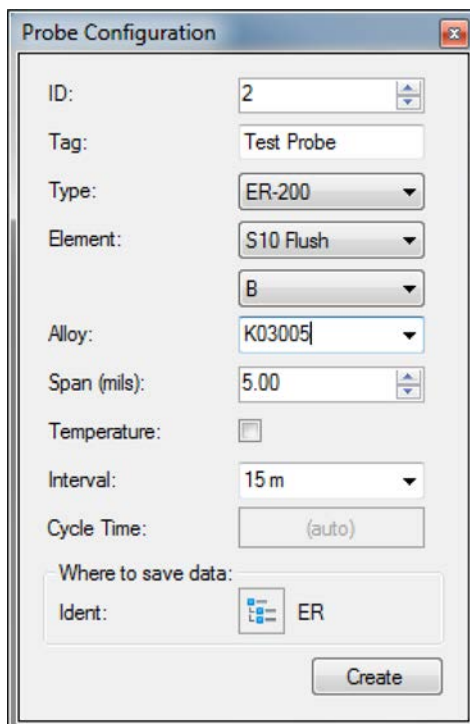

Configure All Probes (continued)

On the window that appears, the user can change the Probe ID, Tag Name, Element, Alloy, Span, if it's a Temperature probe, Interval and Cycle Time depending on what type of probe it is.

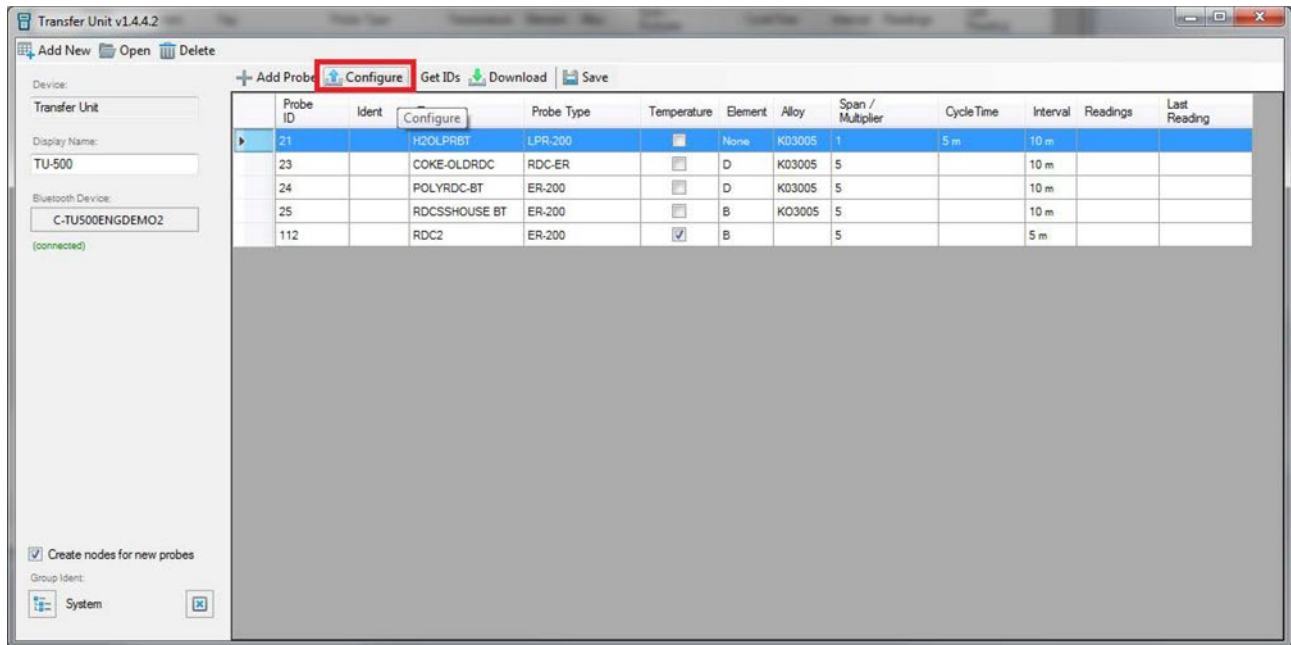

Download Data

Download Individual Probe Data

To download a single probe's data, right click a specific probe and select **Download – ID**.

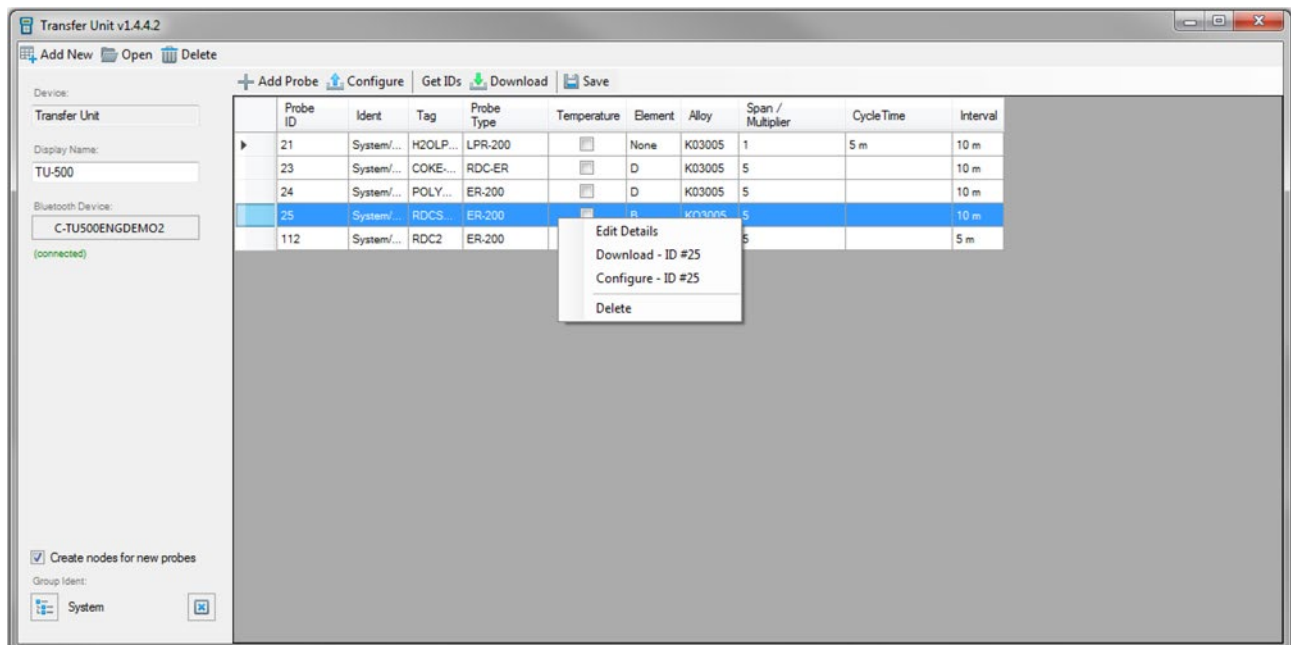

Download Individual Probe Data (continued)

Once the data has finished downloading from the Transfer Unit to the PC the Transfer Unit Driver will display the number of readings and the time of the last reading from the probe. Click **Save** to save the downloaded data. Interval and Cycle Time depending on what type of probe it is.

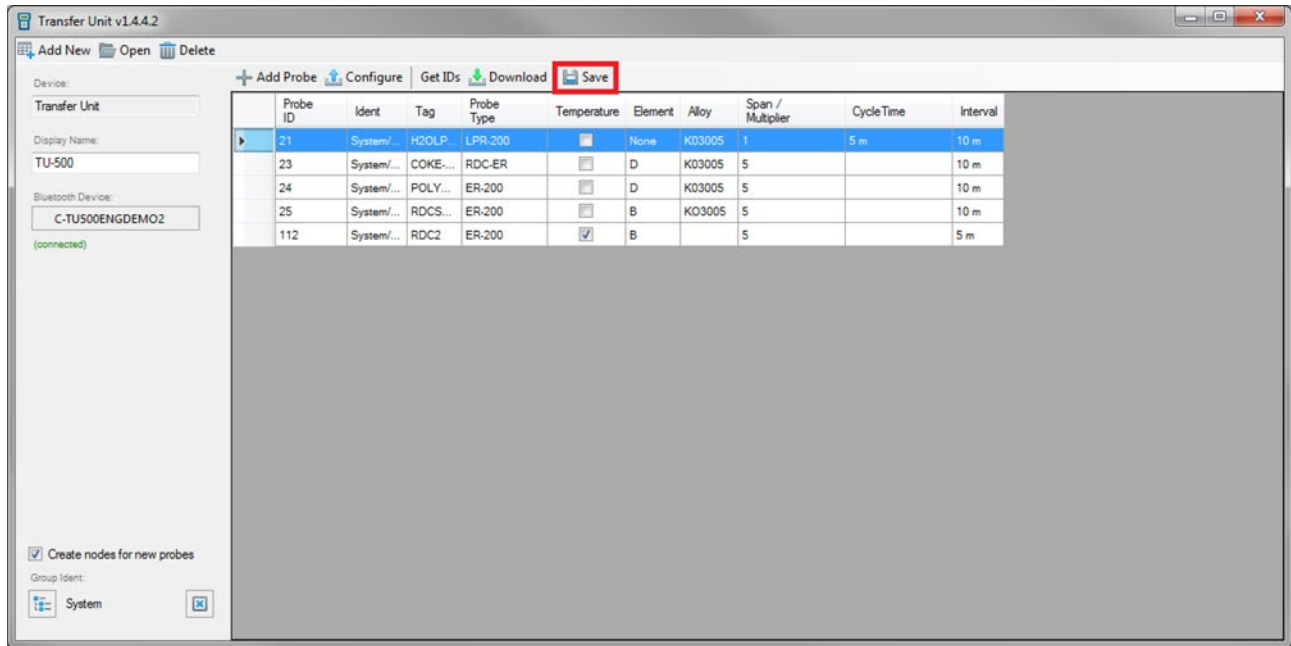

Download All Probe Data

To download data for all the probes on the Transfer Unit, select **Download**.

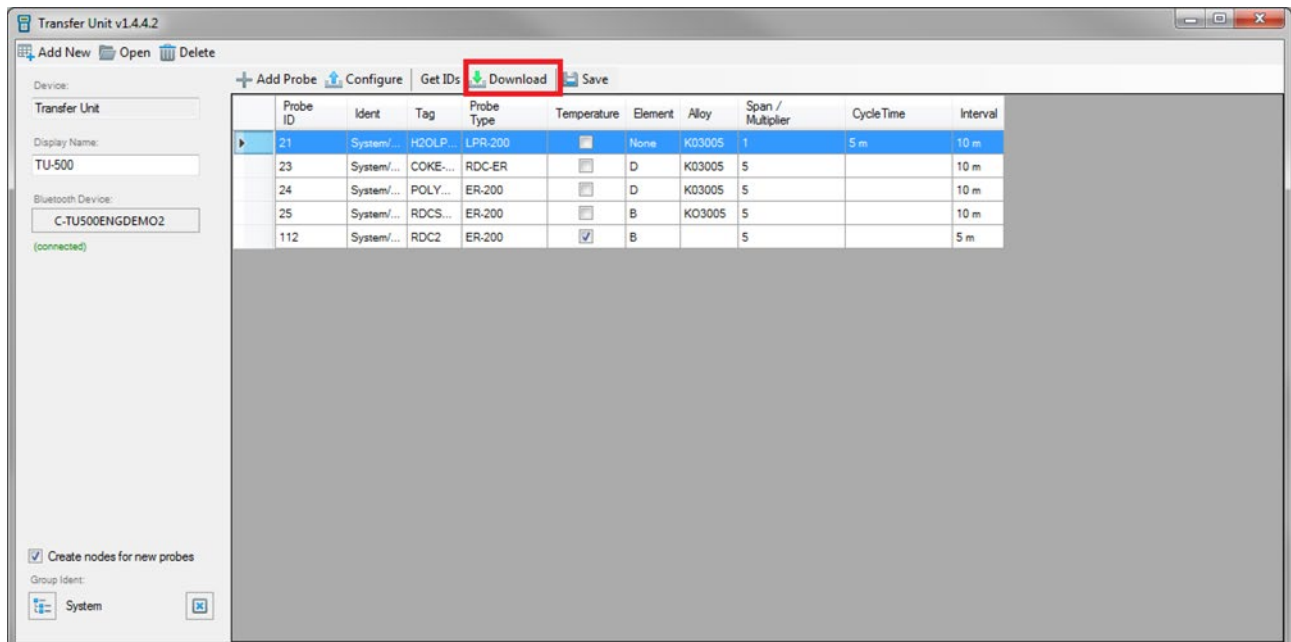

Download All Probe Data (continued)

Once the data has finished downloading from the Transfer Unit to the PC the Transfer Unit Driver will display the number of readings and the time of the last reading from all of the probes on the Transfer Unit. Click **Save** to save the downloaded data.

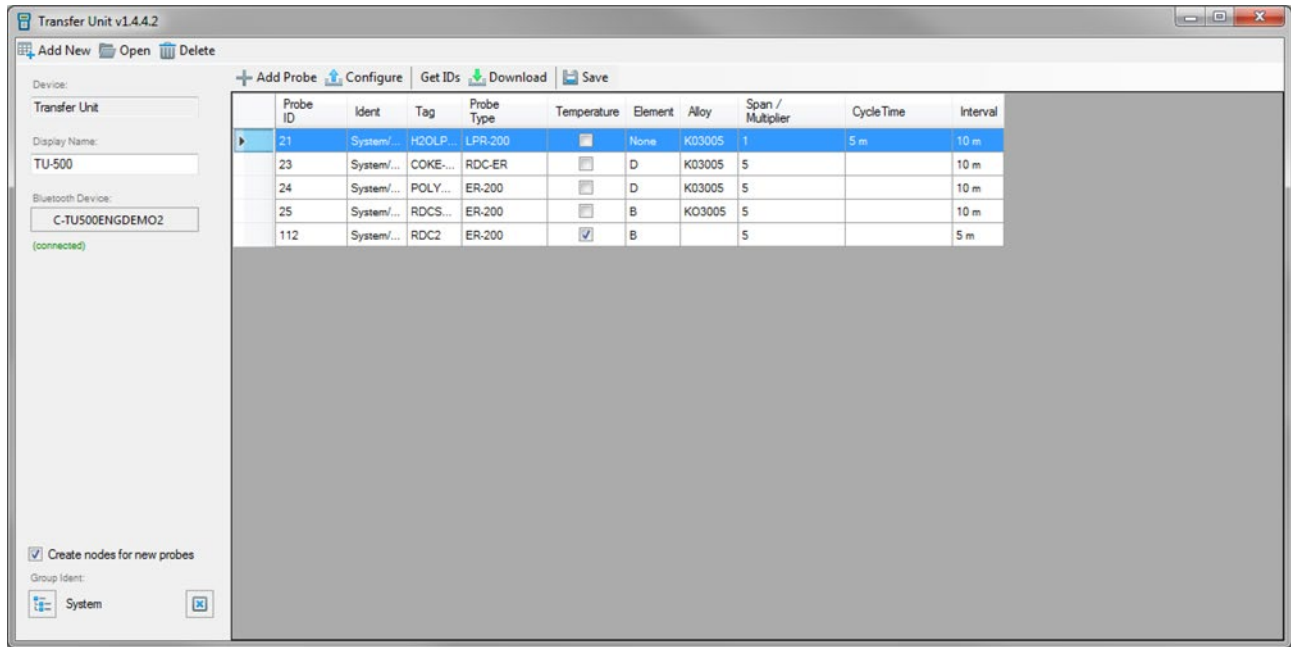

Appendix A

Update Device Firmware

TU-500 Firmware Update Instructions

These instructions describe the proper procedure for updating the firmware for the TU-500.

Required Equipment:

- TU-500 to be updated
- Kinivo Bluetooth USB
- Cosasco BT Wireless USB (P/N 726033)
- PC with USB port

Warning: This operation is intended to be done in a Non-Hazardous Area. This process can take approximately 20 minutes to complete. A close proximity of 3 feet or less is recommended between the Device and the PC.

DO NOT REMOVE BATTERIES UNTIL FIRMWARE UPDATE IS COMPLETED.

1. If not installed, install the drivers for the Kinivo USB device. The drivers are included on the Cosasco BT Wireless USB.

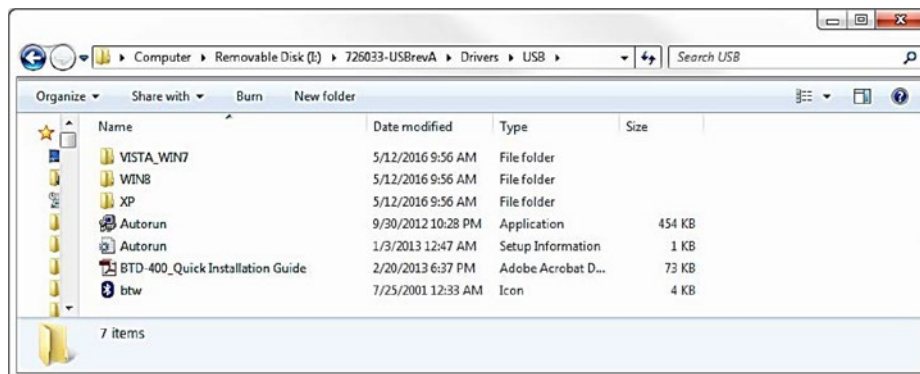

2. If not installed, install the Device Firmware Update Software. The software is included on the Cosasco BT Wireless USB device within the Cosasco Data Installation.

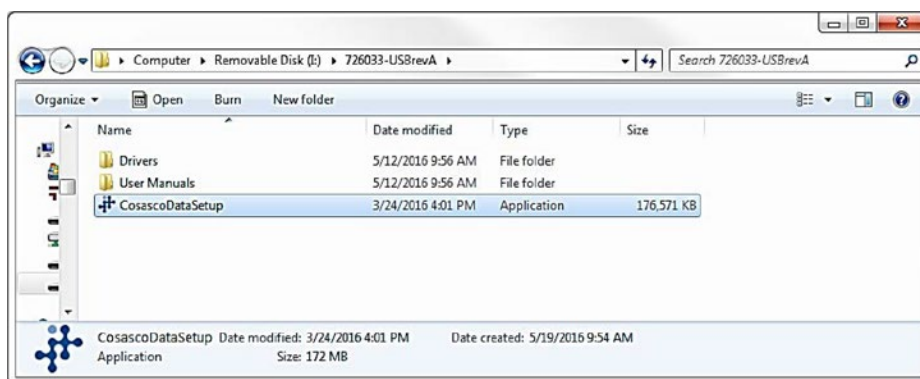

3. Plug in the Kinivo Bluetooth USB device into the PC USB Port. Utilize the USB Ports on the back of a Desktop PC where possible to help avoid errors.

TU-500 Firmware Update Instructions (continued)

4. Open the Device Firmware Update Software. This can typically be found in:
Start → All Programs → Cosasco → Cosasco Data Devices → Device Firmware Update

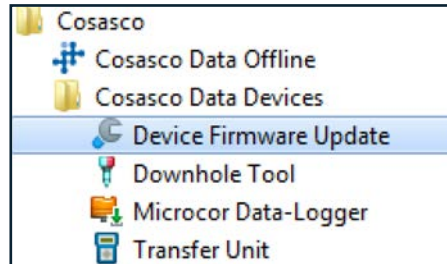

5. Turn on the TU-500 by using the Power Button and select PC on the TU-500 Main Screen.
6. On the Device Firmware Update Window, click “Select Device”, select the TU-500 from the window that has a matching serial number to the back of the device. For example, C-TU500XXXXXXXX, where XXXXXXXX is the serial number for the device you are updating. Then click “OK”.

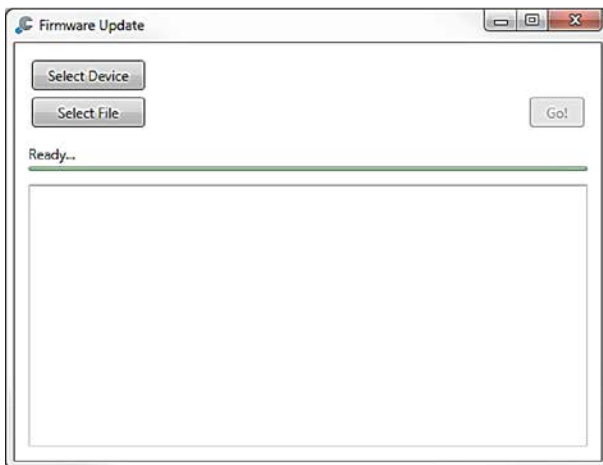

7. On the Device Firmware Update Window, click “Select File”, open the .rcsfirmware version you are trying to apply to the TU-500. EX. “101181 TU-500boot V1_XX.rcsfirmware”
8. If more than 3 minutes have passed since the TU-500 PC mode was selected, you may have to select it again. The TU-500 goes into a low power mode to conserve battery power after 3 minutes of no activity.
9. Click “Go!”.
10. The Device Firmware Update Application should now attempt to connect to the TU-500. The TU-500 will then display “PRODUCTION TEST” then “BOOTLOAD MODE”. The Device Firmware Update Application will have sent the message configuring the device for boot-load mode. If an error occurs here, retry by clicking “Go!”. Once the Device Firmware Update Application has begun, a progress bar will proceed across the screen. After the first progress bar is completed a 2nd progress bar saying “verifying” will proceed across the screen.

TU-500 Firmware Update Instructions (continued)

11. Wait until the Device Firmware Update Window displays “Done”. This can take about 15 minutes to complete.

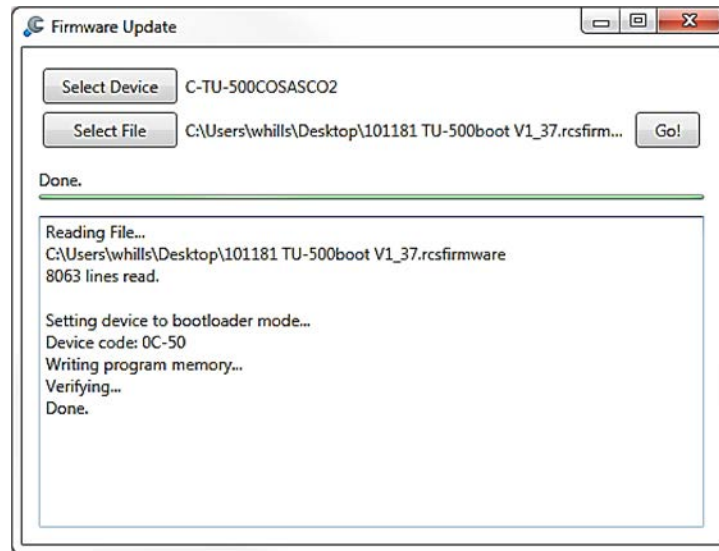

12. Remove batteries from the TU-500 then reinsert them into the TU-500.

Note: Do not remove batteries until firmware update is completed. If Batteries are removed before the firmware update is done the TU-500 will appear broken with black lines across the screen.

13. Power on the TU-500 using the Power Button. The screen will show “Setting Baud to 57k” then proceed to the main screen. This indicates the device is ready for use.

Note: The firmware version in the upper right of the main screen should have now changed to the intended version being updated.

Troubleshooting

If you receive a similar screen to the following:

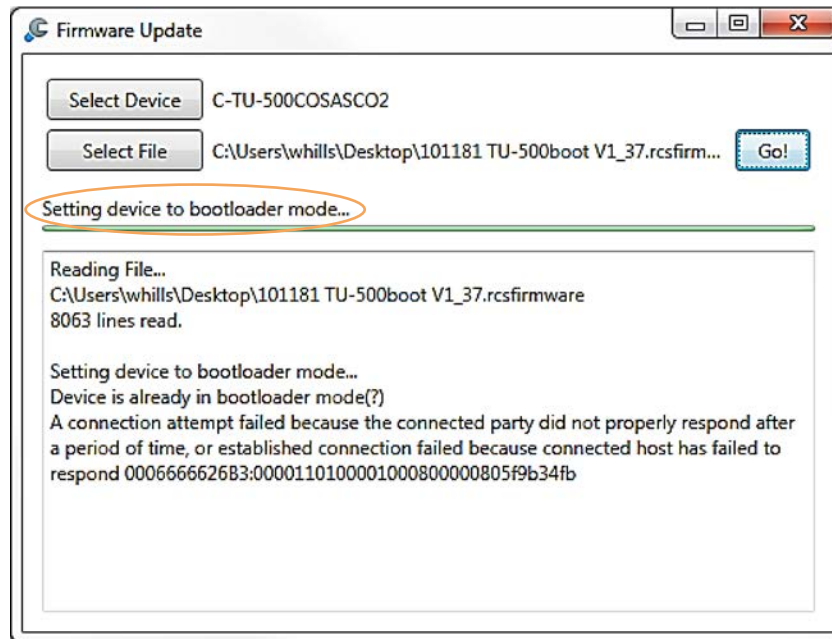

This can be caused by:

- Wrong Device Selected
- TU-500 is off
- TU-500 not set to PC mode

If this occurs start again from step 5.

Troubleshooting (continued)

If you receive a similar screen to the following:

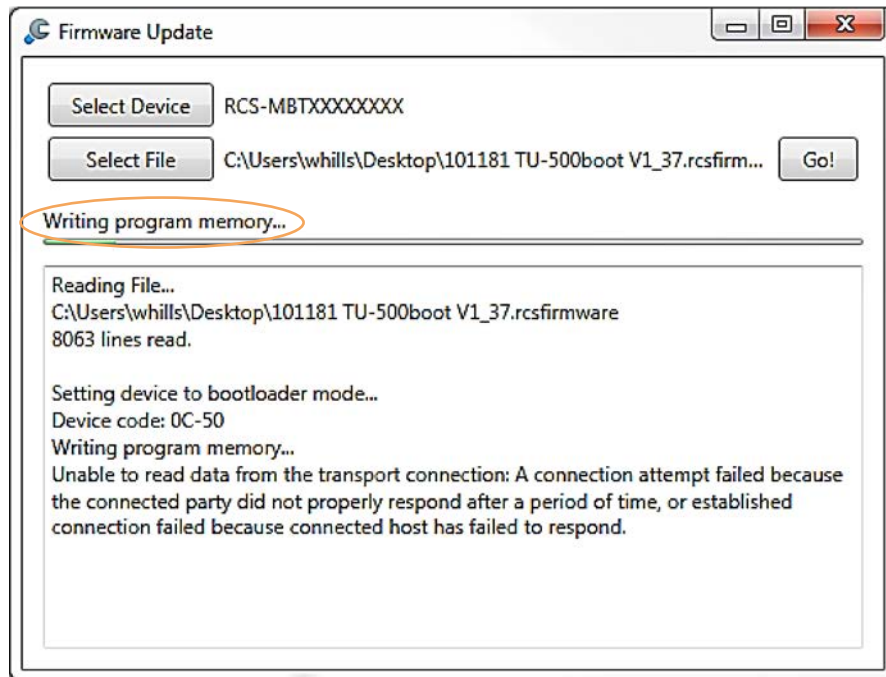

This can be caused by:

- The TU-500 out of range
- Too many devices drawing power from USB port
- Bad USB port on the PC

If this occurs and the front USB ports are being used, unplug any un-needed peripherals attached to the front USB ports. This will optimize performance of the Kinivo USB device. On some PCs, it has been shown to negatively affect the Bluetooth range with multiple devices plugged into the front USB ports. Next, start again from Step 5.

If this occurs and the front USB ports are not being used, start again from Step 5.

Troubleshooting (continued)

If the screen on the TU-500 appears as the following:

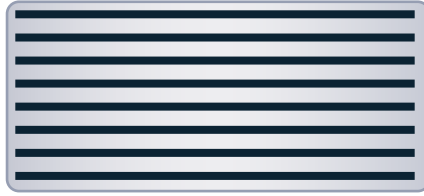

TU-500 Batteries Removed too soon error screen

This can be caused by:

- Batteries removed before update process completed
- Low Batteries

If this occurs start again from Step 5. If this continues to occur replace batteries and proceed from Step 5.

ER-100, LPR-100, ER-200, and LPR-200 Firmware Update Instructions

These instructions describe the proper procedure for updating the firmware for the ER-100, LPR-100, ER-200, and LPR-200.

Required Equipment:

- Device to be updated
- Kinivo Bluetooth USB
- PC with USB port
- Cosasco BT Wireless USB (P/N 726033)

Warning: This operation is intended to be done in a Non-Hazardous Area. This process can take approximately 20 minutes to complete. A close proximity of 3 feet or less is recommended between the Device and the PC.

DO NOT REMOVE BATTERIES UNTIL FIRMWARE UPDATE IS COMPLETED.

1. If not installed, install the drivers for the Kinivo USB device. The drivers are included on the Cosasco BT Wireless USB.

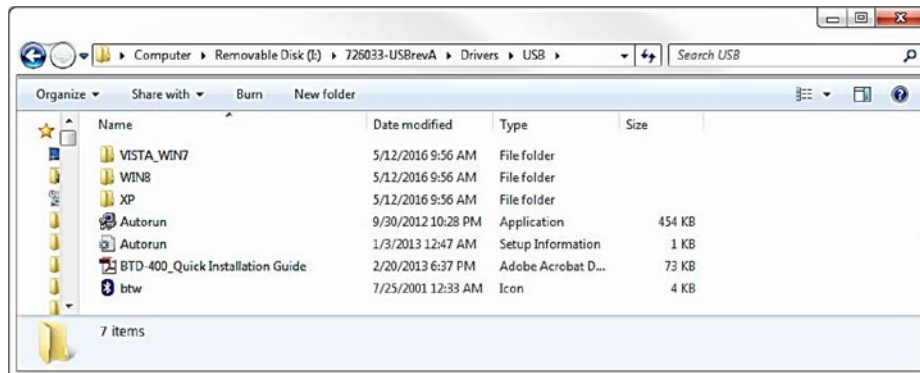

2. If not installed, install the Device Firmware Update Software. The software is included on the Cosasco BT Wireless USB device within the Cosasco Data Installation.

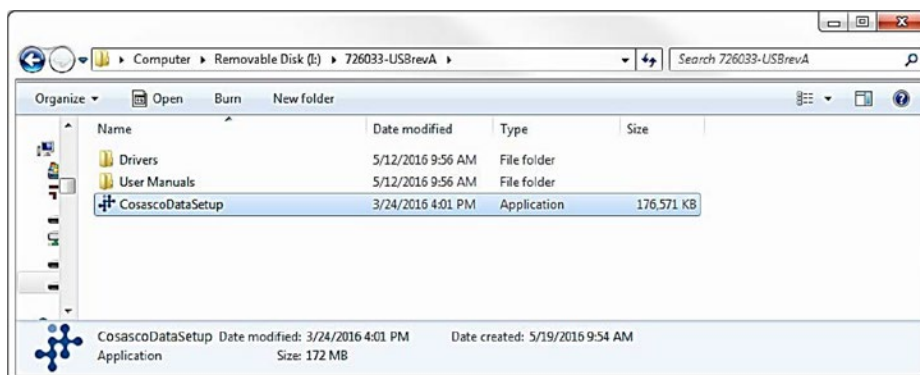

3. Plug in the Kinivo Bluetooth USB device into the PC USB Port. Utilize the USB Ports on the back of a Desktop PC where possible to help avoid errors.

ER-100, LPR-100, ER-200, and LPR-200 Firmware Update Instructions (continued)

- Open the Device Firmware Update Software. This can typically be found in:
Start → All Programs → Cosasco → Cosasco Data Devices → Device Firmware Update

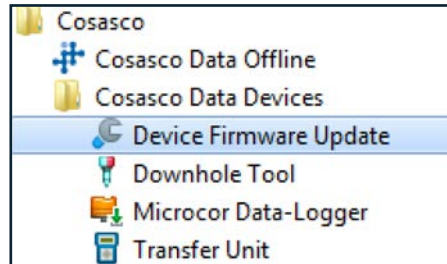

- Turn on the Device by using the Power Button for ER-100 and LPR-100, and by power cycling the battery for the ER-200 and LPR-200.
- On the Device Firmware Update Window, click “Select Device”, select the Device from the window that has a matching serial number to the back of the device. For example, C-ER-100XXXXXXXX, where XXXXXXXX is the serial number for the device you are updating. Then click “OK”.

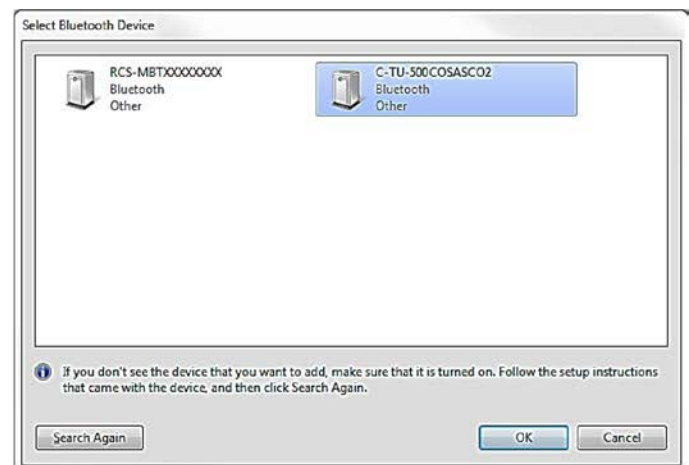
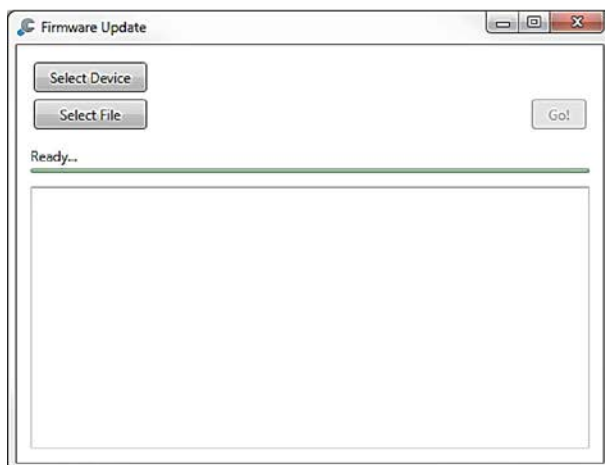

- On the Device Firmware Update Window, click “Select File”, open the .rcsfirmware version you are trying to apply to the device. EX. “101180 ER-100boot_V1_X.rcsfirmware”
- If more than 3 minutes have passed since the Device was powered/power cycled, you may have to power cycle it again. The Devices go into a low power mode to conserve batteries after 3 minutes of no activity.
- Click “Go!”.
- The Device Firmware Application should now attempt to connect to the Device. The Device LED will be a solid green light and then go out. The Device Firmware Application will have sent the message configuring the device for boot-load mode. If an error occurs here, retry by clicking “Go!”. Once the Device Firmware Application has begun, a progress bar will proceed across the screen. After the first progress bar is completed a 2nd progress bar saying “verifying” will proceed across the screen.

ER-100, LPR-100, ER-200, and LPR-200 Firmware Update Instructions (continued)

11. Wait until the Device Firmware Update Window displays “Done”. This can take about 15 minutes to complete.

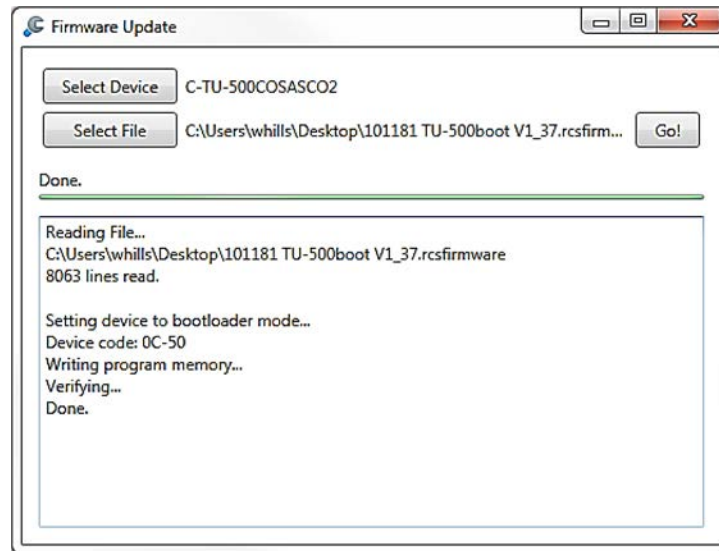

12. For the ER-100 and LPR-100, remove the batteries from the Device then reinsert them into the Device. For the ER-200 and LPR-200, power cycle the battery.

Note: Do not remove batteries until firmware update is completed. Removing the batteries before the firmware update is complete will cause the device to appear broken.

13. Power on the Device using the Power Button. The LED will be flashing green. This indicates the device is ready for use/configuration.

Appendix B

EC Type Examination Certificates

Transfer Unit





1 EC TYPE-EXAMINATION CERTIFICATE

2 Equipment intended for use in Potentially Explosive Atmospheres Directive 94/9/EC

3 Certificate Number: **Sira 14ATEX2263X** Issue: **0**

4 Equipment: **Mate**

5 Applicant: **Rohrback Cosasco Systems**

6 Address: 11841 Smith Ave.
Santa Fe Springs
California 90670
USA

7 This equipment and any acceptable variation thereto is specified in the schedule to this certificate and the documents therein referred to.

8 Sira Certification Service, notified body number 0518 in accordance with Article 9 of Directive 94/9/EC of 23 March 1994, certifies that this equipment has been found to comply with the Essential Health and Safety Requirements relating to the design and construction of equipment intended for use in potentially explosive atmospheres given in Annex II to the Directive.

The examination and test results are recorded in the confidential reports listed in Section 14.2.

9 Compliance with the Essential Health and Safety Requirements, with the exception of those listed in the schedule to this certificate, has been assured by compliance with the following documents:
EN 60079-0:2012/A11:2013 EN 60079-11:2012 EN 60079-26:2015

The above list of documents may detail standards that do not appear on the UKAS Scope of Accreditation, but have been added through Sira's flexible scope of accreditation, which is available on request.

10 If the sign 'X' is placed after the certificate number, it indicates that the equipment is subject to special conditions for safe use specified in the schedule to this certificate.

11 This EC type-examination certificate relates only to the design and construction of the specified equipment. If applicable, further requirements of this Directive apply to the manufacture and supply of this equipment.

12 The marking of the equipment shall include the following:

 II 1G
Ex ia IIC T4 Ga
Ta = -40°C TO +70°C

Project Number 70005218

This certificate and its schedules may only be reproduced in its entirety and without change.

Form 9400 Issue 3



C Ellaby
Deputy Certification Manager

Sira Certification Service
Unit 6, Hawarden Industrial Park,
Hawarden, CH5 3US, United Kingdom

Tel: +44 (0) 1244 670 800
Fax: +44 (0) 1244 539 301
Email: ukinfo@csagroup.org
Web: www.csagroup.org

Page 1 of 2

Transfer Unit (continued)

**SCHEDULE****EC TYPE-EXAMINATION CERTIFICATE****Sira 14ATEX2263X
Issue 0****13 DESCRIPTION OF EQUIPMENT**

The Mate is hand-held equipment that is powered by two, AA size, replaceable, primary cells located in a battery compartment. It consists of a plastic enclosure containing a p.c.b. assembly and a window through which an L.C.D. can be viewed. The front of the enclosure is also fitted with a membrane keypad. The enclosure provides at least IP20 ingress protection.

The intended use of the equipment is for the operator to connect either a Reader-CAT (separately certified as Sira 14ATEX2262X) or a Reader-COT (separately certified as Sira 14ATEX2261X) to probes that are installed on plant. A reading is then taken using the Mate, which communicates with the Readers using a wireless Bluetooth link. The Mate is also intended to be used to communicate with other certified equipment.

14 DESCRIPTIVE DOCUMENTS**14.1 Drawings**

Refer to Certificate Annexe.

14.2 Associated Sira Reports and Certificate History

Issue	Date	Report number	Comment
0	06 July 2015	R70005218A	The release of the prime certificate.

15 SPECIAL CONDITIONS FOR SAFE USE (denoted by X after the certificate number)

- 15.1 No precautions against electrostatic discharge are necessary for hand-held equipment that has an enclosure made of plastic, metal or a combination of the two, except where a significant static-generating mechanism has been identified. Activities such as placing the item in a pocket or on a belt, operating a keypad or cleaning with a damp cloth, do not present a significant electrostatic risk. However, where a static-generating mechanism is identified, such as repeated brushing against clothing, then suitable precautions shall be taken, e.g. the use of anti-static footwear.

16 ESSENTIAL HEALTH AND SAFETY REQUIREMENTS OF ANNEX II (EHSRs)

The relevant EHSRs that are not addressed by the standards listed in this certificate have been identified and individually assessed in the reports listed in Section 14.2.

17 CONDITIONS OF CERTIFICATION

- 17.1 The use of this certificate is subject to the Regulations Applicable to Holders of Sira Certificates.
- 17.2 Holders of EC type-examination certificates are required to comply with the production control requirements defined in Article 8 of directive 94/9/EC.
- 17.3 The Mate incorporates an IS Fusion Limited Type ISF021/T/80 fuse that has previously been Ex Component certified under Sira 05ATEX2274U. It is therefore the responsibility of the manufacturer to continually monitor the status of the certification associated with this device. The manufacturer shall inform CSA-Sira of any modifications to the device that may impinge upon the explosion safety design of the Mate.

This certificate and its schedules may only be reproduced in its entirety and without change.

Sira Certification Service

Unit 6, Hawarden Industrial Park,
Hawarden, CH5 3US, United Kingdom

Tel: +44 (0) 1244 670 800
 Fax: +44 (0) 1244 639 301
 Email: ukinfo@csagroup.org
 Web: www.csagroupuk.org

Form 9400 Issue3

Page 2 of 2

Transfer Unit (continued)

Certificate Annexe**Certificate Number:** Sira 14ATEX2263X**Equipment:** Mate**Applicant:** Rohrback Cosasco Systems**Issue 0**

Drawing no.	Sheets	Rev.	Date (Sira stamp)	Description
723740	1 to 13	A	02 Jul 15	PCB Layout
723748	1 of 1	A	02 Jul 15	PCB Assembly
723752	1 to 4	-	02 Jul 15	Schematic
723765-1	1 of 1	-	02 Jul 15	Certification Label – ATEX and IECEx Detail
723766-1	1 of 1	-	22 Jun 15	Label – Serial Number/Year of Manufacture
723769	1 to 3	-	22 Jun 15	Display Module Detail
726027	1 of 1	-	22 Jun 15	Bluetooth Chip Potting Mold
748599	1 and 2	-	25 Jun 15	General Assembly

This certificate and its schedules may only be reproduced in its entirety and without change.

Form 9400 Issue3

Page 1 of 1

Sira Certification Service

Unit 6, Hawarden Industrial Park,
Hawarden, CH5 3US, United Kingdom

Tel: +44 (0) 1244 670 900
 Fax: +44 (0) 1244 539 301
 Email: ukinfo@csagroup.org
 Web: www.csagroupuk.org

ER Probe Reader



1 **EC TYPE-EXAMINATION CERTIFICATE**

2 Equipment intended for use in Potentially Explosive Atmospheres Directive 94/9/EC

3 Certificate Number: **Sira 14ATEX2261X** Issue: **0**

4 Equipment: **Reader-COT**

5 Applicant: **Rohrback Cosasco Systems**

6 Address: 11841 Smith Ave.
Santa Fe Springs
California 90670
USA

7 This equipment and any acceptable variation thereto is specified in the schedule to this certificate and the documents therein referred to.

8 Sira Certification Service, notified body number 0518 in accordance with Article 9 of Directive 94/9/EC of 23 March 1994, certifies that this equipment has been found to comply with the Essential Health and Safety Requirements relating to the design and construction of equipment intended for use in potentially explosive atmospheres given in Annex II to the Directive.

The examination and test results are recorded in the confidential reports listed in Section 14.2.

9 Compliance with the Essential Health and Safety Requirements, with the exception of those listed in the schedule to this certificate, has been assured by compliance with the following documents:

EN 60079-0:2012/A11:2013 EN 60079-11:2012

The above list of documents may detail standards that do not appear on the UKAS Scope of Accreditation, but have been added through Sira's flexible scope of accreditation, which is available on request.

10 If the sign 'X' is placed after the certificate number, it indicates that the equipment is subject to special conditions for safe use specified in the schedule to this certificate.

11 This EC type-examination certificate relates only to the design and construction of the specified equipment. If applicable, further requirements of this Directive apply to the manufacture and supply of this equipment.

12 The marking of the equipment shall include the following:

 II 2G
Ex ib IIC T4 Gb
Tamb = -40°C to +70°C

Project Number 70004817

C Ellaby
Deputy Certification Manager

This certificate and its schedules may only be reproduced in its entirety and without change.

Sira Certification Service

Unit 8, Hawarden Industrial Park,
Hawarden, CH5 3US, United Kingdom

Tel: +44 (0) 1244 870 900
Fax: +44 (0) 1244 539 301
Email: ukinfo@csagroup.org
Web: www.csagroupuk.org

Form 9400 Issue 3

Page 1 of 2

ER Probe Reader (continued)

**SCHEDULE****EC TYPE-EXAMINATION CERTIFICATE****Sira 14ATEX2261X
Issue 0****13 DESCRIPTION OF EQUIPMENT**

The Reader-COT is 'carried by the person' equipment and is powered by two AA size replaceable primary cells located in a battery compartment. These cells may be replaced in the hazardous area.

It consists of a plastic enclosure containing a p.c.b. assembly. One end of the enclosure is fitted with a membrane off/on switch and LED indicator. The other end of the enclosure is fitted with a connector intended to be connected to an external probe. The enclosure provides at least IP20 ingress protection.

The intended use of the equipment is for the operator to carry the Reader-COT to probes that are installed on plant and connect the Reader-COT to these probes and then take a reading using a Mate, which is a separately certified (Sira 14ATEX2263X) hand-held piece of equipment which communicates to the Reader-COT via a wireless Bluetooth link.

The intrinsic safety parameters at the probe connector are:

U _i = 0	U _o = 5.36V	C _i = 0	C _o = 65µF
I _i = 0	I _o = 0.329A	L _i = 35nH	L _o = 328µH
P _i = 0	P _o = 0.45W		L _o /R _o = 80µH/Ω

14 DESCRIPTIVE DOCUMENTS**14.1 Drawings**

Refer to Certificate Annexe.

14.2 Associated Sira Reports and Certificate History

Issue	Date	Report number	Comment
0	25 June 2015	R70004817A	The release of the prime certificate.

15 SPECIAL CONDITIONS FOR SAFE USE (denoted by X after the certificate number)

- 15.1 No precautions against electrostatic discharge are necessary for equipment carried by the person that has an enclosure made of plastic, metal or a combination of the two, except where a significant static-generating mechanism has been identified. Activities such as placing the item in a pocket or on a belt, operating a keypad or cleaning with a damp cloth, do not present a significant electrostatic risk. However, where a static-generating mechanism is identified, such as repeated brushing against clothing, then suitable precautions shall be taken, e.g. the use of anti-static footwear.

16 ESSENTIAL HEALTH AND SAFETY REQUIREMENTS OF ANNEX II (EHSRs)

The relevant EHSRs that are not addressed by the standards listed in this certificate have been identified and individually assessed in the reports listed in Section 14.2.

17 CONDITIONS OF CERTIFICATION

- 17.1 The use of this certificate is subject to the Regulations Applicable to Holders of Sira Certificates.
- 17.2 Holders of EC type-examination certificates are required to comply with the production control requirements defined in Article 8 of directive 94/9/EC.
- 17.3 The Reader-COT incorporates an IS Fusion Limited Type ISF021/T/80 fuse that has previously been Ex Component certified under Sira 05ATEX2274U. It is therefore the responsibility of the manufacturer to continually monitor the status of the certification associated with this device. The manufacturer shall inform CSA-Sira of any modifications to the device that may impinge upon the explosion safety design of the Reader-COT.

This certificate and its schedules may only be reproduced in its entirety and without change.

Sira Certification Service

Unit 6, Hawarden Industrial Park,
Hawarden, CH5 3US, United Kingdom

Tel: +44 (0) 1244 670 800
Fax: +44 (0) 1244 639 301
Email: ukinfo@csagroup.org
Web: www.csagroupuk.org

Form 9400 Issue3

Page 2 of 2

ER Probe Reader (continued)

Certificate Annexe

Certificate Number: Sira 14ATEX2261X
Equipment: Reader-COT
Applicant: Rohrback Cosasco Systems

Issue 0

Drawing no.	Sheets	Rev.	Date (Sira stamp)	Description
726000	1 to 13	A	21 May 15	PCB Layout
726002	1 of 1	A	21 May 15	PCB Assembly
726016	1 to 5	-	21 May 15	Schematic
726029-1	1 of 1	-	25 Jun 15	Certification Label – ATEX and IECEx Detail
726026-1	1 of 1	-	21 May 15	Label – Serial Number/Year of Manufacture
726027	1 of 1	-	21 May 15	Bluetooth Chip Potting Mold
748596	1 and 2	-	25 Jun 15	General Assembly

This certificate and its schedules may only be reproduced in its entirety and without change.

Form 9400 Issue3

Page 1 of 1

Sira Certification Service

Unit 6, Hawarden Industrial Park,
 Hawarden, CH5 3US, United Kingdom

Tel: +44 (0) 1244 670 900
 Fax: +44 (0) 1244 539 301
 Email: ukinfo@csagroup.org
 Web: www.csagroupuk.org

LPR Probe Reader



1 EC TYPE-EXAMINATION CERTIFICATE

2 Equipment intended for use in Potentially Explosive Atmospheres Directive 94/9/EC

3 Certificate Number: **Sira 14ATEX2262X** Issue: **0**

4 Equipment: **Reader-CAT**

5 Applicant: **Rohrback Cosasco Systems**

6 Address: 11841 Smith Ave.
Santa Fe Springs
California 90670
USA

7 This equipment and any acceptable variation thereto is specified in the schedule to this certificate and the documents therein referred to.

8 Sira Certification Service, notified body number 0518 in accordance with Article 9 of Directive 94/9/EC of 23 March 1994, certifies that this equipment has been found to comply with the Essential Health and Safety Requirements relating to the design and construction of equipment intended for use in potentially explosive atmospheres given in Annex II to the Directive.

The examination and test results are recorded in the confidential reports listed in Section 14.2.

9 Compliance with the Essential Health and Safety Requirements, with the exception of those listed in the schedule to this certificate, has been assured by compliance with the following documents:

EN 60079-0:2012/A11:2013 EN 60079-11:2012

The above list of documents may detail standards that do not appear on the UKAS Scope of Accreditation, but have been added through Sira's flexible scope of accreditation, which is available on request.

10 If the sign 'X' is placed after the certificate number, it indicates that the equipment is subject to special conditions for safe use specified in the schedule to this certificate.

11 This EC type-examination certificate relates only to the design and construction of the specified equipment. If applicable, further requirements of this Directive apply to the manufacture and supply of this equipment.

12 The marking of the equipment shall include the following:



II 2G
Ex ib IIC T4 Gb
Tamb = -40°C to +70°C

Project Number 70005219

C Ellaby
Deputy Certification Manager

This certificate and its schedules may only be reproduced in its entirety and without change.

Sira Certification Service

Unit 6, Hawarden Industrial Park,
Hawarden, CH5 3US, United Kingdom

Tel: +44 (0) 1244 870 900
Fax: +44 (0) 1244 539 301
Email: ukinfo@csagroup.org
Web: www.csagrouk.org

Form 9400 Issue 3

Page 1 of 2

LPR Probe Reader (continued)

**SCHEDULE****EC TYPE-EXAMINATION CERTIFICATE**

Sira 14ATEX2262X
Issue 0

13 DESCRIPTION OF EQUIPMENT

The Reader-CAT is 'carried by the person' equipment that is powered by two AA size replaceable primary cells located in a battery compartment. These cells may be replaced in the hazardous area. It consists of a plastic enclosure containing a p.c.b. assembly. One end of the enclosure is fitted with a membrane off/on switch and LED indicator. The other end of the enclosure is fitted with a connector intended to be connected to an external probe. The enclosure provides at least IP20 ingress protection.

The intended use of the equipment is for the operator to carry the Reader-CAT to probes that are installed on plant and connect the Reader-CAT to these probes and then take a reading using a Mate, which is a separately certified (Sira 14ATEX2263X) hand-held piece of equipment which communicates to the Reader-CAT via a wireless Bluetooth link.

The Reader-CAT has the following parameters at the probe connector:

$U_i = 0$ $P_i = 0$ $I_o = 67.2\text{mA}$ $C_i = 0$ $C_o = 65\mu\text{F}$ $L_o = 7.87\text{mH}$
 $I_i = 0$ $U_o = 5.36\text{V}$ $P_o = 90\text{mW}$ $L_i = 35\text{nH}$ $L_o/R_o = 395\mu\text{H}/\Omega$

14 DESCRIPTIVE DOCUMENTS**14.1 Drawings**

Refer to Certificate Annexe.

14.2 Associated Sira Reports and Certificate History

Issue	Date	Report number	Comment
0	25 June 2015	R70005219A	The release of the prime certificate.

15 SPECIAL CONDITIONS FOR SAFE USE (denoted by X after the certificate number)

- 15.1** No precautions against electrostatic discharge are necessary for equipment carried by the person that has an enclosure made of plastic, metal or a combination of the two, except where a significant static-generating mechanism has been identified. Activities such as placing the item in a pocket or on a belt, operating a keypad or cleaning with a damp cloth, do not present a significant electrostatic risk. However, where a static-generating mechanism is identified, such as repeated brushing against clothing, then suitable precautions shall be taken, e.g. the use of anti-static footwear.

16 ESSENTIAL HEALTH AND SAFETY REQUIREMENTS OF ANNEX II (EHSRs)

The relevant EHSRs that are not addressed by the standards listed in this certificate have been identified and individually assessed in the reports listed in Section 14.2.

17 CONDITIONS OF CERTIFICATION

- 17.1** The use of this certificate is subject to the Regulations Applicable to Holders of Sira Certificates.
- 17.2** Holders of EC type-examination certificates are required to comply with the production control requirements defined in Article 8 of directive 94/9/EC.
- 17.3** The Reader-CAT incorporates an IS Fusion Limited Type ISF021/T/80 fuse that has previously been Ex Component certified under Sira 05ATEX2274U. It is therefore the responsibility of the manufacturer to continually monitor the status of the certification associated with this device. The manufacturer shall inform CSA-Sira of any modifications to the device that may impinge upon the explosion safety design of the Reader-CAT.

This certificate and its schedules may only be reproduced in its entirety and without change.

Sira Certification Service

Unit 6, Hawarden Industrial Park,
Hawarden, CH5 3US, United Kingdom

Tel: +44 (0) 1244 670 900
Fax: +44 (0) 1244 539 301
Email: ukinfo@csagroup.org
Web: www.csagroupuk.org

Form 9400 Issue3

Page 2 of 2

Legacy Converter



- 1 **EC TYPE-EXAMINATION CERTIFICATE**
- 2 Equipment intended for use in Potentially Explosive Atmospheres Directive 94/9/EC
- 3 Certificate Number: **Sira 14ATEX2264X** Issue: **0**
- 4 Equipment: **Converter***
- 5 Applicant: **Rohrbach Cosasco Systems**
- 6 Address: 11841 Smith Ave.
Santa Fe Springs
California 90670
USA
- 7 This equipment and any acceptable variation thereto is specified in the schedule to this certificate and the documents therein referred to.
- 8 Sira Certification Service, notified body number 0518 in accordance with Article 9 of Directive 94/9/EC of 23 March 1994, certifies that this equipment has been found to comply with the Essential Health and Safety Requirements relating to the design and construction of equipment intended for use in potentially explosive atmospheres given in Annex II to the Directive.
The examination and test results are recorded in the confidential reports listed in Section 14.2.
- 9 Compliance with the Essential Health and Safety Requirements, with the exception of those listed in the schedule to this certificate, has been assured by compliance with the following documents:
EN 60079-0:2012/A11:2013 EN 60079-11:2012
The above list of documents may detail standards that do not appear on the UKAS Scope of Accreditation, but have been added through Sira's flexible scope of accreditation, which is available on request.
- 10 If the sign 'X' is placed after the certificate number, it indicates that the equipment is subject to special conditions for safe use specified in the schedule to this certificate.
- 11 This EC type-examination certificate relates only to the design and construction of the specified equipment. If applicable, further requirements of this Directive apply to the manufacture and supply of this equipment.
- 12 The marking of the equipment shall include the following:

II 2G
Ex ib IIC T4 Gb
Ta = -40°C to +70°C

Project Number 70008375

This certificate and its schedules may only be reproduced in its entirety and without change.

Form 9400 Issue 3

Page 1 of 3

C Ellaby
Deputy Certification Manager

Sira Certification Service

Unit 6, Hawarden Industrial Park,
Hawarden, CH5 3US, United Kingdom

Tel: +44 (0) 1244 670 900
Fax: +44 (0) 1244 539 301
Email: ukinfo@csagroup.org
Web: www.csagroupuk.org

Legacy Converter (continued)



SCHEDULE

EC TYPE-EXAMINATION CERTIFICATE

**Sira 14ATEX2264X
Issue 0**

13 DESCRIPTION OF EQUIPMENT

The Converter* is 'carried by the person' equipment that is powered by two AA size replaceable primary cells located in a battery compartment. These cells may be replaced in the hazardous area.

It consists of a plastic enclosure containing a p.c.b. assembly. One end of the enclosure is fitted with an off/on switch and LED indicator. The other end of the enclosure is fitted with two 'RS 232' connectors (a 'LEMO' connector and an 'AMPHENOL' connector) that are internally connected in parallel and which are intended to be connected to equipment installed on plant. The enclosure provides at least IP20 ingress protection.

The intended use of the equipment is for the operator to carry the Converter to the equipment installed on plant, connect the Converter to this equipment, and take a reading using a Mate, which is a separately-certified (Sira 14ATEX2263X) hand-held piece of equipment that communicates to the Converter via a wireless Bluetooth link.

The intrinsic safety parameters at the 'RS 232' connectors are as follows:

Tx and Rx pins combined w.r.t. GND pin:				
U _i = 11.1 V	I _i = n/a	P _i = n/a	C _i = 0	L _i = 35 nH
U _o = 11.1 V	I _o = 22.5 mA	P _o = 62.3 mW		
Tx pin w.r.t. Rx pin:				
U _i = 22.2 V	I _i = n/a	P _i = n/a	C _i = 0	L _i = 35 nH
U _o = 22.2 V	I _o = 11.3 mA	P _o = 62.3 mW		

The load parameters are as follows:

Gas Group	Maximum external capacitance (C _o)	Maximum external inductance (L _o)	Maximum external inductance to resistance ratio (L _o /R _o)
IIC	0.16 µF	70 mH	571 µH/Ω
IIB	1.11 µF	280 mH	2.28 mH/Ω
IIA	4.08 µF	560 mH	4.57 mH/Ω

14 DESCRIPTIVE DOCUMENTS

14.1 Drawings

Refer to Certificate Annexe.

14.2 Associated Sira Reports and Certificate History

Issue	Date	Report no.	Comment
0	26 June 2015	R70008375A	The release of the prime certificate.

15 SPECIAL CONDITIONS FOR SAFE USE (denoted by X after the certificate number)

- 15.1 No precautions against electrostatic discharge are necessary for equipment carried by the person that has an enclosure made of plastic, metal or a combination of the two, except where a significant static-generating mechanism has been identified. Activities such as placing the item in a pocket or on a belt, operating a keypad or cleaning with a damp cloth, do not present a significant electrostatic risk. However, where a static-generating mechanism is identified, such as repeated brushing against clothing, then suitable precautions shall be taken, e.g. the use of anti-static footwear.

This certificate and its schedules may only be reproduced in its entirety and without change.

Sira Certification Service

Unit 6, Hawarden Industrial Park,
Hawarden, CH5 3US, United Kingdom

Tel: +44 (0) 1244 670 800
 Fax: +44 (0) 1244 539 301
 Email: ukinfo@csagroup.org
 Web: www.csagroupuk.org

Form 9400 Issue3

Page 2 of 3

Legacy Converter (continued)

**SCHEDULE****EC TYPE-EXAMINATION CERTIFICATE**

Sira 14ATEX2264X
Issue 0

16 ESSENTIAL HEALTH AND SAFETY REQUIREMENTS OF ANNEX II (EHSRs)

The relevant EHSRs that are not addressed by the standards listed in this certificate have been identified and individually assessed in the reports listed in Section 14.2.

17 CONDITIONS OF CERTIFICATION

- 17.1 The use of this certificate is subject to the Regulations Applicable to Holders of Sira Certificates.
- 17.2 Holders of EC type-examination certificates are required to comply with the production control requirements defined in Article 8 of directive 94/9/EC.
- 17.3 The Converter* incorporates an IS Fusion Limited Type ISF021/T/80 fuse that has previously been Ex Component certified under Sira 05ATEX2274U. It is therefore the responsibility of the manufacturer to continually monitor the status of the certification associated with this device. The manufacturer shall inform CSA-Sira of any modifications to the device that may impinge upon the explosion safety design of the Converter*.

This certificate and its schedules may only be reproduced in its entirety and without change.

Form 9400 Issue3

Page 3 of 3

Sira Certification Service

Unit 6, Hawarden Industrial Park,
Hawarden, CH5 3US, United Kingdom

Tel: +44 (0) 1244 670 900
Fax: +44 (0) 1244 539 301
Email: ukinfo@csagroup.org
Web: www.csagrouk.org

Legacy Converter (continued)

Certificate Annexe**Certificate Number:** Sira 14ATEX2264X**Equipment:** Converter**Applicant:** Rohrback Cosasco Systems**Issue 0**

Drawing no.	Sheets	Rev.	Date (Sira stamp)	Description
723743	1 to 13	-	16 Jun 15	PCB Layout
723751	1 of 1	-	16 Jun 15	PCB Assembly
723753	1 of 1	-	16 Jun 15	Schematic
723768-1	1 of 1	-	25 Jun 15	Certification Label – ATEX and IECEx Detail
723776-1	1 of 1	-	16 Jun 15	RS 232 IC Potting Mold
723781-1	1 of 1	-	16 Jun 15	Label – Serial Number/Year of Manufacture
726027	1 of 1	-	16 Jun 15	Bluetooth Chip Potting Mold
748600	1 to 3	-	25 Jun 15	General Assembly

This certificate and its schedules may only be reproduced in its entirety and without change.

Form 9400 Issue3

Page 1 of 1

Sira Certification Service

Unit 6, Hawarden Industrial Park,
Hawarden, CH5 3US, United Kingdom

Tel: +44 (0) 1244 670 900
 Fax: +44 (0) 1244 539 301
 Email: ukinfo@csagroup.org
 Web: www.csagroupuk.org

ER Datalogger



1 EC TYPE-EXAMINATION CERTIFICATE

2 Equipment intended for use in Potentially Explosive Atmospheres Directive 94/9/EC

3 Certificate Number: **Sira 16ATEX2024X** Issue: **0**

4 Equipment: **RDC2-COT* and RDC2-COT-G***

5 Applicant: **Rohrback Cosasco Systems**

6 Address: 11841 Smith Ave.
Santa Fe Springs
California 90670
USA

7 This equipment and any acceptable variation thereto is specified in the schedule to this certificate and the documents therein referred to.

8 Sira Certification Service, notified body number 0518 in accordance with Article 9 of Directive 94/9/EC of 23 March 1994, certifies that this equipment has been found to comply with the Essential Health and Safety Requirements relating to the design and construction of equipment intended for use in potentially explosive atmospheres given in Annex II to the Directive.

The examination and test results are recorded in the confidential reports listed in Section 14.2.

9 Compliance with the Essential Health and Safety Requirements, with the exception of those listed in the schedule to this certificate, has been assured by compliance with the following documents:

EN 60079-0:2012/A11:2013 EN 60079-11:2012 EN 60079-26:2015

The above list of documents may detail standards that do not appear on the UKAS Scope of Accreditation, but have been added through Sira's flexible scope of accreditation, which is available on request.

10 If the sign 'X' is placed after the certificate number, it indicates that the equipment is subject to special conditions for safe use specified in the schedule to this certificate.

11 This EC type-examination certificate relates only to the design and construction of the specified equipment. If applicable, further requirements of this Directive apply to the manufacture and supply of this equipment.

12 The marking of the equipment shall include the following:



II 1G
Ex ia IIC T4 Ga
Tamb = -40°C to +70°C

Project Number 70008420

This certificate and its schedules may only be reproduced in its entirety and without change.

Form 9400 Issue 3

Page 1 of 3

C Ellaby
Deputy Certification Manager

Sira Certification Service

Unit 6, Hawarden Industrial Park,
Hawarden, CH5 3US, United Kingdom

Tel: +44 (0) 1244 670 900
Fax: +44 (0) 1244 539 301
Email: ukinfo@csagroup.org
Web: www.csagroupuk.org

ER Datalogger (continued)



SCHEDULE

EC TYPE-EXAMINATION CERTIFICATE

**Sira 16ATEX2024X
Issue 0**

13 DESCRIPTION OF EQUIPMENT

The RDC2-COT* and RDC2-COT-G* Data Loggers are fixed equipment and use an enclosure that is made from either fibreglass (with polyester mounts) or a stainless steel. The enclosure, which provides at least IP 20 ingress protection, contains a main p.c.b. assembly and an internal source of power, this source of power is an RCS RDC2 Battery Pack that incorporates two, D size, primary cells and is identified as part number 726043; a second, 'adapter' p.c.b. assembly may be mounted on the main p.c.b. The Battery Pack can only be replaced by another RCS RDC2 Pack but it can be changed even when an explosive atmosphere is present.

One end of the enclosure has a permanently connected cable that enters the enclosure via a cable gland, the intension being that the cable is connected to an RCS/Cosasco simple apparatus probe (not covered by this certification). This end of the enclosure is also fitted with a vent/drain. The other end of the enclosure may have up to two, RF coaxial connector/adapters fitted, these are connected to an external antenna by the user.

It is intended that an operator takes a reading from the RDC2-COT* or RDC2-COT-G* using a Mate, which is a separately certified (Sira 14ATEX2263X/IECEx SIR 14.0096X), hand-held, piece of equipment; or other suitably certified hand-held equipment (including a phone) running RCS application software; the two devices communicate via a wireless, Bluetooth link.

The intrinsic safety parameters at the permanently connected cable are:

U_i = 0 I_i = 0 P_i = 0
U_o = 5.36 V I_o = 0.329 A P_o = 0.45 W C_o = 64.9 µF L_o = 300 µH L_o/R_o = 53 µH/Ω

The intrinsic safety parameters at the RF coaxial connectors are:

U_i = 0 I_i = 0 P_i = 0 C_i = 30.4 µF L_i = 35 nH
U_o = 5.3 6V I_o = 0.894 A P_o = 0.95 W C_o = 1.6 µF L_o = 44.4 µH (A max. of 2 µH shall be discrete inductance, the balance being allowed as cable inductance)

14 DESCRIPTIVE DOCUMENTS

14.1 Drawings

Refer to Certificate Annexe.

14.2 Associated Sira Reports and Certificate History

Issue	Date	Report no.	Comment
0	03 February 2016	R70008420A	The release of the prime certificate.

15 SPECIAL CONDITIONS FOR SAFE USE (denoted by X after the certificate number)

15.1 Under certain extreme circumstances, the exposed plastic/fibre glass surfaces of the non-metallic enclosure version of the equipment may generate, and its unearthed metal parts may store, an ignition-capable level of electrostatic charge. Therefore this version of the equipment shall not be installed in a location where the external conditions are conducive to the build-up of electrostatic charge on the enclosure surfaces. In addition, the equipment shall only be cleaned with a damp cloth. This is particularly important if the equipment is installed in a Zone 0 location.

This certificate and its schedules may only be reproduced in its entirety and without change.

Sira Certification Service

Unit 6, Hawarden Industrial Park,
Hawarden, CH6 3US, United Kingdom

Tel: +44 (0) 1244 070 800
Fax: +44 (0) 1244 539 301
Email: ukinfo@csagroup.org
Web: www.csagroupuk.org

Form 9400 Issue3

Page 2 of 3

ER Datalogger (continued)

**SCHEDULE****EC TYPE-EXAMINATION CERTIFICATE**

Sira 16ATEX2024X
Issue 0

- 15.2 The maximum radio power output at the RF connectors is 1W. Any antenna fitted shall not result in the radiated power exceeding 2 W when any antenna gain is taken into account.
- 15.3 The RDC2-COT-G* version of the equipment is not capable of passing a 500 V dielectric strength test, according to Clause 6.3.13 of EN 60079-11, between its intrinsically safe circuits and its enclosure. This shall be taken into account in any equipment installation.
- 16 **ESSENTIAL HEALTH AND SAFETY REQUIREMENTS OF ANNEX II (EHSRs)**
The relevant EHSRs that are not addressed by the standards listed in this certificate have been identified and individually assessed in the reports listed in Section 14.2.
- 17 **CONDITIONS OF CERTIFICATION**
- 17.1 The use of this certificate is subject to the Regulations Applicable to Holders of Sira Certificates.
- 17.2 Holders of EC type-examination certificates are required to comply with the production control requirements defined in Article 8 of directive 94/9/EC.
- 17.3 The RDC2-COT* and RDC2-COT-G* incorporates an IS Fusion Limited Type ISF021/T/80 fuse that has previously been Ex Component certified under Sira 05ATEX2274U. It is therefore the responsibility of the manufacturer to continually monitor the status of the certification associated with this device. The manufacturer shall inform CSA-Sira of any modifications to the device that may impinge upon the explosion safety design of the RDC2-COT* and RDC2-COT-G*.

This certificate and its schedules may only be reproduced in its entirety and without change.

Form 9400 Issue3

Page 3 of 3

Sira Certification Service

Unit 8, Hawarden Industrial Park,
Hawarden, CH5 3US, United Kingdom

Tel: +44 (0) 1244 670 900
Fax: +44 (0) 1244 539 301
Email: ukinfo@csagroup.org
Web: www.csagroupuk.org

ER Datalogger (continued)

Certificate Annexe

Certificate Number: Sira 16ATEX2024X
Equipment: RDC2-COT⁺ and RDC2-COT-G⁺
Applicant: Rohrback Cosasco Systems

Issue 0

Drawing no.	Sheets	Rev.	Date (Sira stamp)	Description
726008	1 to 13	-	28 Jan 16	Main PCB Layout
726010	1 of 1	-	28 Jan 16	Main PCB Assembly
726015	1 to 7	-	28 Jan 16	Main PCB Schematic
726017	1 of 1	-	28 Jan 16	Adapter Board Schematic
726021	1 to 10	-	28 Jan 16	Adapter Board PCB Layout
726023	1 of 1	-	28 Jan 16	Adapter Board Assembly
726027	1 of 1	-	28 Jan 16	Bluetooth Chip Potting Mould
726043-1	1 of 1	-	28 Jan 16	Battery Pack - Detail
726044-1	1 of 1	-	28 Jan 16	Battery Pack - Label
726046-1	1 of 1	-	28 Jan 16	Certification Label – ATEX and IECEx Detail
726062	1 of 1	-	29 Jan 16	Control Drawing Detailing Equipment Configurations and Intrinsic Safety Parameters
748598	1 and 2	-	28 Jan 16	General Assembly

This certificate and its schedules may only be reproduced in its entirety and without change.

Form 9400 Issue3

Page 1 of 1

Sira Certification Service

Unit 6, Hawarden Industrial Park,
 Hawarden, CH5 3US, United Kingdom

Tel: +44 (0) 1244 670 800
 Fax: +44 (0) 1244 539 301
 Email: ukinfo@csagroup.org
 Web: www.csagroupuk.org

LPR Datalogger



1 EC TYPE-EXAMINATION CERTIFICATE

2 Equipment intended for use in Potentially Explosive Atmospheres Directive 94/9/EC

3 Certificate Number: **Sira 16ATEX2025X** Issue: **0**

4 Equipment: **RDC2-CAT* and RDC2-CAT-G***

5 Applicant: **Rohrback Cosasco Systems**

6 Address: 11841 Smith Ave.
Santa Fe Springs
California 90670
USA

7 This equipment and any acceptable variation thereto is specified in the schedule to this certificate and the documents therein referred to.

8 Sira Certification Service, notified body number 0518 in accordance with Article 9 of Directive 94/9/EC of 23 March 1994, certifies that this equipment has been found to comply with the Essential Health and Safety Requirements relating to the design and construction of equipment intended for use in potentially explosive atmospheres given in Annex II to the Directive.

The examination and test results are recorded in the confidential reports listed in Section 14.2.

9 Compliance with the Essential Health and Safety Requirements, with the exception of those listed in the schedule to this certificate, has been assured by compliance with the following documents:

EN 60079-0:2012/A11:2013 EN 60079-11:2012 EN 60079-26:2015

The above list of documents may detail standards that do not appear on the UKAS Scope of Accreditation, but have been added through Sira's flexible scope of accreditation, which is available on request.

10 If the sign 'X' is placed after the certificate number, it indicates that the equipment is subject to special conditions for safe use specified in the schedule to this certificate.

11 This EC type-examination certificate relates only to the design and construction of the specified equipment. If applicable, further requirements of this Directive apply to the manufacture and supply of this equipment.

12 The marking of the equipment shall include the following:

II 1G
Ex ia IIC T4 Ga
Tamb = -40°C to +70°C

Project Number 70014314

C Ellaby
Deputy Certification Manager

This certificate and its schedules may only be reproduced in its entirety and without change.

Sira Certification Service

Unit 8, Hawarden Industrial Park,
Hawarden, CH5 3US, United Kingdom

Tel: +44 (0) 1244 870 900
Fax: +44 (0) 1244 539 301
Email: ukinfo@csagroup.org
Web: www.csagroupuk.org

Form 9400 Issue 3

Page 1 of 3

LPR Datalogger (continued)



SCHEDULE

EC TYPE-EXAMINATION CERTIFICATE

**Sira 16ATEX2025X
Issue 0**

13 DESCRIPTION OF EQUIPMENT

The RDC2-CAT* and RDC2-CAT-G* Data Loggers are fixed equipment and use an enclosure that is made from either fibreglass (with polyester mounts) or a stainless steel. The enclosure, which provides at least IP 20 ingress protection, contains a main p.c.b. assembly and an internal source of power, this source of power is an RCS RDC2 Battery Pack that incorporates two, D size, primary cells and is identified as part number 726043; a second, 'adapter' p.c.b. assembly may be mounted on the main p.c.b. The Battery Pack can only be replaced by another RCS RDC2 Pack but it can be changed even when an explosive atmosphere is present.

One end of the enclosure has a permanently connected cable that enters the enclosure via a cable gland, the intension being that the cable is connected to an RCS/Cosasco simple apparatus probe (not covered by this certification). This end of the enclosure is also fitted with a vent/drain. The other end of the enclosure may have up to two, RF coaxial connector/adapters fitted, these are connected to an external antenna by the user.

It is intended that an operator takes a reading from the RDC2-CAT* or RDC2-CAT-G* using a Mate, which is a separately certified (Sira 14ATEX2263X/IECEx SIR 14.0096X), hand-held, piece of equipment; or other suitably certified hand-held equipment (including a phone) running RCS application software; the two devices communicate via a wireless, Bluetooth link.

The intrinsic safety parameters at the permanently connected cable are:

U_i = 0 I_i = 0 P_i = 0
U_o = 5.36 V I_o = 67.2 mA P_o = 90 mW C_o = 64.9 µF L_o = 300 µH L_o/R_o = 390 µH/Ω

The intrinsic safety parameters at the RF coaxial connectors are:

U_i = 0 I_i = 0 P_i = 0 C_i = 29.24µF L_i = 35nH
U_o = 5.3 6 V I_o = 0.938 A P_o = 0.95 W C_o = 760 nF L_o = 40.3 µH (A max. of 2 µH shall be discrete inductance, the balance being allowed as cable inductance)

14 DESCRIPTIVE DOCUMENTS

14.1 Drawings

Refer to Certificate Annexe.

14.2 Associated Sira Reports and Certificate History

Issue	Date	Report number	Comment
0	03 February 2016	R70014314A	The release of the prime certificate.

15 SPECIAL CONDITIONS FOR SAFE USE (denoted by X after the certificate number)

15.1 Under certain extreme circumstances, the exposed plastic/fibre glass surfaces of the non-metallic enclosure version of the equipment may generate, and its unearthed metal parts may store, an ignition-capable level of electrostatic charge. Therefore this version of the equipment shall not be installed in a location where the external conditions are conducive to the build-up of electrostatic charge on the enclosure surfaces. In addition, the equipment shall only be cleaned with a damp cloth. This is particularly important if the equipment is installed in a Zone 0 location.

This certificate and its schedules may only be reproduced in its entirety and without change.

Sira Certification Service

Unit 6, Hawarden Industrial Park,
Hawarden, CH5 3US, United Kingdom

Tel: +44 (0) 1244 670 800
Fax: +44 (0) 1244 539 301
Email: ukinfo@csagroup.org
Web: www.csagroupuk.org

Form 9400 Issue3

Page 2 of 3

LPR Datalogger (continued)

**SCHEDULE****EC TYPE-EXAMINATION CERTIFICATE**

Sira 16ATEX2025X
Issue 0

- 15.2 The maximum radio power output at the RF connectors is 1W. Any antenna fitted shall not result in the radiated power exceeding 2W when any antenna gain is taken into account.
- 15.3 The RDC2-CAT-G* version of the equipment is not capable of passing a 500V dielectric strength test, according to Clause 6.3.13 of EN 60079-11, between its intrinsically safe circuits and its enclosure. This shall be taken into account in any equipment installation.
- 16 **ESSENTIAL HEALTH AND SAFETY REQUIREMENTS OF ANNEX II (EHSRs)**
The relevant EHSRs that are not addressed by the standards listed in this certificate have been identified and individually assessed in the reports listed in Section 14.2.
- 17 **CONDITIONS OF CERTIFICATION**
- 17.1 The use of this certificate is subject to the Regulations Applicable to Holders of Sira Certificates.
- 17.2 Holders of EC type-examination certificates are required to comply with the production control requirements defined in Article 8 of directive 94/9/EC.
- 17.3 The RDC2-CAT* and RDC2-CAT-G* incorporates an IS Fusion Limited Type ISF021/T/80 fuse that has previously been Ex Component certified under Sira 05ATEX2274U. It is therefore the responsibility of the manufacturer to continually monitor the status of the certification associated with this device. The manufacturer shall inform CSA-Sira of any modifications to the device that may impinge upon the explosion safety design of the RDC2-CAT* and RDC2-CAT-G*.

This certificate and its schedules may only be reproduced in its entirety and without change.

Form 9400 Issue3

Page 3 of 3

Sira Certification Service

Unit 6, Hawarden Industrial Park,
Hawarden, CH5 3US, United Kingdom

Tel: +44 (0) 1244 670 900
Fax: +44 (0) 1244 539 301
Email: ukinfo@csagroup.org
Web: www.csagroupuk.org

LPR Datalogger (continued)

Certificate Annexe

Certificate Number: Sira 16ATEX2025X
Equipment: RDC2-CAT* and RDC2-CAT-G*
Applicant: Rohrback Cosasco Systems

Issue 0

Drawing no.	Sheets	Rev.	Date (Sira stamp)	Description
726017	1 of 1	-	28 Jan 16	Adapter Board Schematic
726021	1 to 10	-	28 Jan 16	Adapter Board PCB Layout
726023	1 of 1	-	28 Jan 16	Adapter Board Assembly
726027	1 of 1	-	28 Jan 16	Bluetooth Chip Potting Mold
726039	1 to 13	-	28 Jan 16	Main PCB Layout
726041	1 of 1	-	28 Jan 16	Main PCB Assembly
726042	1 to 5	-	28 Jan 16	Main PCB Schematic
726043-1	1 of 1	-	28 Jan 16	Battery Pack - Detail
726044-1	1 of 1	-	28 Jan 16	Battery Pack - Label
726053-1	1 of 1	-	28 Jan 16	Certification Label – ATEX and IECEx Detail
726061	1 of 1	-	29 Jan 16	Control Drawing Detailing Equipment Configurations and Intrinsic Safety Parameters
748603	1 and 2	-	28 Jan 16	General Assembly

This certificate and its schedules may only be reproduced in its entirety and without change.

Form 9400 Issue3

Page 1 of 1

Sira Certification Service

Unit 8, Hawarden Industrial Park,
 Hawarden, CH5 3US, United Kingdom

Tel: +44 (0) 1244 670 900
 Fax: +44 (0) 1244 539 301
 Email: ukinfo@csagroup.org
 Web: www.csagroupuk.org

M-200

The M-200 uses the same certifications as the MWT-3905.

1	EC-TYPE EXAMINATION CERTIFICATE	
2	Equipment or Protective systems intended for use in Potentially Explosive Atmospheres - Directive 94/9/EC	
3	EC-Type Examination Certificate No:	FM09ATEX0018X
4	Equipment or protective system: (Type Reference and Name)	MWT-3905 Microcor Wireless Transmitter
5	Name of Applicant:	Rohrbach Cosasco Systems
6	Address of Applicant:	11841 East Smith Ave Santa Fe Springs, CA 90670 USA
7	This equipment or protective system and any acceptable variation thereto is specified in the schedule to this certificate and documents therein referred to.	
8	FM Approvals Ltd, notified body number 1725 in accordance with Article 9 of Directive 94/9/EC of 23 March 1994, certifies that this equipment has been found to comply with the Essential Health and Safety Requirements relating to the design and construction of equipment intended for use in potentially explosive atmospheres given in Annex II to the Directive. The examination and test results are recorded in confidential report number 3032790EC dated 15 October 2009.	
9	Compliance with the Essential Health and Safety Requirements, with the exception of those identified in item 15 of the schedule to this certificate, has been assessed by compliance with the following documents: EN 60079-0:2006, EN 60079-1:2007, EN 60529:1991 +A1:2000, EN 60079-11:2007	
10	If the sign 'X' is placed after the certificate number, it indicates that the equipment is subject to special conditions for safe use specified in the schedule to this certificate.	
11	This EC-Type Examination certificate relates only to the design, examination and tests of the specified equipment or protective system in accordance to the directive 94/9/EC. Further requirements of the Directive apply to the manufacturing process and supply of this equipment or protective system. These are not covered by this certificate.	
12	The marking of the equipment or protective system shall include:	
		II 2 G Ex d [ib] IIC T4 Ta = -40°C to +70°C IP66
		
	Ron Webb Deputy Certification Manager, FM Approvals Ltd.	 <small>Member of the FM Global Group</small>
	Issue date: 26 October 2009	
	<u>THIS CERTIFICATE MAY ONLY BE REPRODUCED IN ITS ENTIRETY AND WITHOUT CHANGE</u>	
	FM Approvals Ltd. 1 Windsor Dials, Windsor, Berkshire, UK. SL4 1RS T: +44 (0) 1753 750 000 F: +44 (0) 1753 868 700 E-mail: atex@fmapprovals.com www.fmglobal.com	
	FM F ATEX 020 (Feb/07)	Page 1 of 3

M-200 (continued)

SCHEDULE



EC-Type Examination Certificate No. FM09ATEX0018X

13 Description of Equipment or Protective System:

The MWT-3905 Microcor Wireless Transmitter measures corrosion and transmits data via a wireless connection. The transmitter consists of a 6061-T6 aluminum enclosure consisting of a cover that threads onto the base. The enclosure has 2 compartments that are separated by an internal separator plate. The top compartment portion contains an intrinsically safe battery and the bottom compartment portion of the enclosure is flameproof Ex d. The battery provides power to the circuits in the Ex d compartment via a stainless steel Power Module Port feedthrough. Three other stainless steel feedthroughs connect to the Ex d compartment portion of the enclosure and provide intrinsically safe outputs; the Antenna Port, Data Port and Probe Port feedthroughs. DURALCO 4864 compound is present in each feedthrough to form a cement joint. As the transmitter is powered via the battery, there are no connection entries to the enclosure, other than the external port feedthroughs. O-rings are provided on the thread-on cover as well as on the port feedthroughs to provide ingress protection.

The MWT-3905 Microcor Wireless Transmitter is certified for use only with Power MODULE P/N 748400.

14 Special Conditions for Safe Use:

The MWT-3905 shall only be used with the 748400 Battery Pack.

15 Essential Health and Safety Requirements:

The relevant EHSRs that have not been addressed by the standards listed in this certificate have been identified and assessed in the confidential report identified in item 8.

16 Test and Assessment Procedure and Conditions:

This EC-Type Examination Certificate is the result of testing of a sample of the product submitted, in accordance with the provisions of the relevant specific standard(s), and assessment of supporting documentation. It does not imply an assessment of the whole production.

Whilst this certificate may be used in support of a manufacturer's claim for CE Marking, FM Approvals Ltd accepts no responsibility for the compliance of the equipment against all applicable Directives in all applications.

This Certificate has been issued in accordance with FM Approvals Ltd's ATEX Certification Scheme.

17 Approved Drawings

Drawing No:	Revision	Title / Description
702430	E	PCB Assy, Analog Board
702431	C	PCB Fab, Analog Board
702432	C	Schematic, Analog Board
702425	E	PCB Assy, Intrinsic Safety Board
702426	B	PCB Fab, Intrinsic Safety Board
702427	D	Schematic, Intrinsic Safety Board

THIS CERTIFICATE MAY ONLY BE REPRODUCED IN ITS ENTIRETY AND WITHOUT CHANGE

FM Approvals Ltd, 1 Windsor Dials, Windsor, Berkshire, UK, SL4 1RS
T: +44 (0) 1753 750 000 F: +44 (0) 1753 868 700 E-mail: atex@fmapprovals.com www.fmglobal.com

FM F ATEX 020 (Feb/07)

Page 2 of 3



M-200 (continued)

SCHEDULE		
EC-Type Examination Certificate No. FM09ATEX0018X		
 <small>Member of the FM Global Group</small>		
17	Approved Drawings	
Drawing No:	Revision	Title / Description
702461	B	Nameplate, Microcor Wireless Transmitter
702402	B	Certification Drawing
702401-Quickstart	(-)	Safety Manual, MWT-3905
702408	C	MWT-3905 Intrinsic Safety
<u>THIS CERTIFICATE MAY ONLY BE REPRODUCED IN ITS ENTIRETY AND WITHOUT CHANGE</u>		
<small>FM Approvals Ltd. 1 Windsor Dials, Windsor, Berkshire, UK. SL4 1RS T: +44 (0) 1753 750 000 F: +44 (0) 1753 868 700 E-mail: atex@fmapprovals.com www.fmglobal.com</small>		
<small>FM F ATEX 020 (Feb/07)</small>		<small>Page 3 of 3</small>

Appendix C

Certificates of Conformity

Transfer Unit

IEC		IECEX		IECEX Certificate of Conformity	
INTERNATIONAL ELECTROTECHNICAL COMMISSION IEC Certification Scheme for Explosive Atmospheres <small>for rules and details of the IECEX Scheme visit www.iecex.com</small>					
Certificate No.:	IECEX SIR 14.0096X	issue No.:	0	Certificate history:	
Status:	Current				
Date of Issue:	2015-07-06	Page 1 of 3			
Applicant:	Rohrback Cosasco Systems 11841 Smith Ave. Santa Fe Springs California 90670 United States of America				
Electrical Apparatus:	Mate				
Optional accessory:					
Type of Protection:	Intrinsically Safe				
Marking:	Ex ia IIC T4 Ga Ta = -40°C TO +70°C				
Approved for issue on behalf of the IECEX Certification Body:	C Ellaby				
Position:	Deputy Certification Manager				
Signature: (for printed version)					
Date:	<u>2015-07-06</u>				
1. This certificate and schedule may only be reproduced in full. 2. This certificate is not transferable and remains the property of the issuing body. 3. The Status and authenticity of this certificate may be verified by visiting the Official IECEX Website .					
Certificate issued by: SIRA Certification Service CSA Group Unit 6, Hawarden Industrial Park Hawarden Deeside CH5 3US United Kingdom					
			 		

Transfer Unit (continued)

IEC		IECEX		IECEX Certificate of Conformity	
Certificate No.:	IECEX SIR 14.0096X				
Date of Issue:	2015-07-06	Issue No.:	0		
			Page 2 of 3		
Manufacturer:	Rohrback Cosasco Systems 11841 Smith Ave. Santa Fe Springs California 90670 United States of America				
Additional Manufacturing location (s):					
<p>This certificate is issued as verification that a sample(s), representative of production, was assessed and tested and found to comply with the IEC Standard list below and that the manufacturer's quality system, relating to the Ex products covered by this certificate, was assessed and found to comply with the IECEX Quality system requirements. This certificate is granted subject to the conditions as set out in IECEX Scheme Rules, IECEX 02 and Operational Documents as amended.</p>					
STANDARDS:					
The electrical apparatus and any acceptable variations to it specified in the schedule of this certificate and the identified documents, was found to comply with the following standards:					
IEC 60079-0 : 2011 Edition: 6.0	Explosive atmospheres - Part 0: General requirements				
IEC 60079-11 : 2011 Edition: 6.0	Explosive atmospheres - Part 11: Equipment protection by intrinsic safety "I"				
IEC 60079-26 : 2014-10 Edition: 3.0	Explosive atmospheres – Part 26: Equipment with Equipment Protection Level (EPL) Ga				
<i>This Certificate does not indicate compliance with electrical safety and performance requirements other than those expressly included in the Standards listed above.</i>					
TEST & ASSESSMENT REPORTS:					
A sample(s) of the equipment listed has successfully met the examination and test requirements as recorded in					
<u>Test Report:</u>					
GB/SIR/ExTR15.0182/00					
<u>Quality Assessment Report:</u>					
US/UL/QAR08.0005/04					

Transfer Unit (continued)

		<h2 style="margin: 0;">IECEX Certificate of Conformity</h2>	
Certificate No.:	IECEX SIR 14.0096X	Issue No.:	0
Date of Issue:	2015-07-06	Page	3 of 3
Schedule			
EQUIPMENT:			
<i>Equipment and systems covered by this certificate are as follows:</i>			
<p>The Mate is hand-held equipment that is powered by two, AA size, replaceable, primary cells located in a battery compartment. It consists of a plastic enclosure containing a p.c.b. assembly and a window through which an L.C.D. can be viewed. The front of the enclosure is also fitted with a membrane keypad. The enclosure provides at least IP20 ingress protection.</p> <p>The intended use of the equipment is for the operator to connect either a Reader-CAT (separately certified as IECEX SIR 14.0095X) or a Reader-COT (separately certified as IECEX 14.0094X) to probes that are installed on plant. A reading is then taken using the Mate, which communicates with the Readers using a wireless Bluetooth link. The Mate is also intended to be used to communicate with other certified equipment.</p>			
Conditions of manufacture			
The Manufacturer shall comply with the following:			
1.	The Mate incorporates an IS Fusion Limited Type ISF021/T/80 fuse that has previously been Ex Component certified under IECEX SIR 07.0050U. It is therefore the responsibility of the manufacturer to continually monitor the status of the certification associated with this device. The manufacturer shall inform CSA-Sira of any modifications to the device that may impinge upon the explosion safety design of the Mate.		
CONDITIONS OF CERTIFICATION: YES as shown below:			
1.	No precautions against electrostatic discharge are necessary for hand-held equipment that has an enclosure made of plastic, metal or a combination of the two, except where a significant static-generating mechanism has been identified. Activities such as placing the item in a pocket or on a belt, operating a keypad or cleaning with a damp cloth, do not present a significant electrostatic risk. However, where a static-generating mechanism is identified, such as repeated brushing against clothing, then suitable precautions shall be taken, e.g. the use of anti-static footwear.		

ER Probe Reader

		<h2>IECEX Certificate of Conformity</h2>	
<p>INTERNATIONAL ELECTROTECHNICAL COMMISSION IEC Certification Scheme for Explosive Atmospheres <small>for rules and details of the IECEx Scheme visit www.iecex.com</small></p>			
Certificate No.:	IECEX SIR 14.0094X	issue No.:	0
Status:	Current	Certificate history:	
Date of Issue:	2015-06-15	Page 1 of 4	
Applicant:	Rohrbach Cosasco Systems 11841 Smith Ave Santa Fe Springs California 90670 United States of America		
Electrical Apparatus:	Reader-COT		
Optional accessory:			
Type of Protection:	Intrinsically Safe		
Marking:	Ex Ib IIC T4 Gb Tamb = -40°C To +70°C		
Approved for issue on behalf of the IECEx Certification Body:	C Ellaby		
Position:	Deputy Certification Manager		
Signature: (for printed version)			
Date:	2015-06-15		
1. This certificate and schedule may only be reproduced in full. 2. This certificate is not transferable and remains the property of the issuing body. 3. The Status and authenticity of this certificate may be verified by visiting the Official IECEx Website.			
Certificate issued by: SIRA Certification Service CSA Group Unit 6, Hawarden Industrial Park Hawarden Deeside CH5 3US United Kingdom			



ER Probe Reader (continued)

		<h2 style="text-align: center;">IECEX Certificate of Conformity</h2>	
Certificate No.:	IECEX SIR 14.0094X	Issue No.:	0
Date of Issue:	2015-06-15	Page 2 of 4	
Manufacturer:	Rohrback Cosasco Systems 11841 Smith Ave. Santa Fe Springs California 90670 United States of America		
Additional Manufacturing location (s):			
<p>This certificate is issued as verification that a sample(s), representative of production, was assessed and tested and found to comply with the IEC Standard list below and that the manufacturer's quality system, relating to the Ex products covered by this certificate, was assessed and found to comply with the IECEx Quality system requirements. This certificate is granted subject to the conditions as set out in IECEx Scheme Rules, IECEx 02 and Operational Documents as amended.</p>			
STANDARDS:			
The electrical apparatus and any acceptable variations to it specified in the schedule of this certificate and the identified documents, was found to comply with the following standards:			
IEC 60079-0 : 2011 Edition: 6.0	Explosive atmospheres - Part 0: General requirements		
IEC 60079-11 : 2011 Edition: 6.0	Explosive atmospheres - Part 11: Equipment protection by intrinsic safety "i"		
<i>This Certificate does not indicate compliance with electrical safety and performance requirements other than those expressly included in the Standards listed above.</i>			
TEST & ASSESSMENT REPORTS:			
A sample(s) of the equipment listed has successfully met the examination and test requirements as recorded in			
<u>Test Report:</u>			
GB/SIR/EXTR15.0152/00			
<u>Quality Assessment Report:</u>			
US/UL/QAR08.0005/04			

ER Probe Reader (continued)

		<h2 style="margin: 0;">IECEX Certificate of Conformity</h2>													
Certificate No.:	IECEX SIR 14.0094X	Issue No.:	0												
Date of Issue:	2015-06-15	Page 3 of 4													
Schedule															
EQUIPMENT:															
<i>Equipment and systems covered by this certificate are as follows:</i>															
<p>The Reader-COT is 'carried by the person' equipment and is powered by two AA size replaceable primary cells located in a battery compartment. These cells may be replaced in the hazardous area.</p> <p>It consists of a plastic enclosure containing a p.c.b. assembly. One end of the enclosure is fitted with a membrane off/on switch and LED indicator. The other end of the enclosure is fitted with a connector intended to be connected to an external probe. The enclosure provides at least IP20 ingress protection.</p> <p>The intended use of the equipment is for the operator to carry the Reader-COT to probes that are installed on plant and connect the Reader-COT to these probes and then take a reading using a Mate, which is a separately certified (IECEX SIR 14.0096X) hand-held piece of equipment which communicates to the Reader-COT via a wireless Bluetooth link.</p> <p>The intrinsic safety parameters at the probe connector are:</p> <table border="0" style="width: 100%; border-collapse: collapse;"> <tr> <td style="width: 25%;">U_i = 0</td> <td style="width: 25%;">U_o = 5.36V</td> <td style="width: 25%;">C_i = 0</td> <td style="width: 25%;">C_o = 65µF</td> </tr> <tr> <td>l_i = 0</td> <td>l_o = 0.329A</td> <td>l_i = 35nH</td> <td>l_o = 328µH</td> </tr> <tr> <td>P_i = 0</td> <td>P_o = 0.45W</td> <td></td> <td>Lo/Ro = 80µH/Ω</td> </tr> </table>				U _i = 0	U _o = 5.36V	C _i = 0	C _o = 65µF	l _i = 0	l _o = 0.329A	l _i = 35nH	l _o = 328µH	P _i = 0	P _o = 0.45W		Lo/Ro = 80µH/Ω
U _i = 0	U _o = 5.36V	C _i = 0	C _o = 65µF												
l _i = 0	l _o = 0.329A	l _i = 35nH	l _o = 328µH												
P _i = 0	P _o = 0.45W		Lo/Ro = 80µH/Ω												
CONDITIONS OF CERTIFICATION: YES as shown below:															
1.	<p>No precautions against electrostatic discharge are necessary for equipment carried by the person that has an enclosure made of plastic, metal or a combination of the two, except where a significant static-generating mechanism has been identified. Activities such as placing the item in a pocket or on a belt, operating a keypad or cleaning with a damp cloth, do not present a significant electrostatic risk. However, where a static-generating mechanism is identified, such as repeated brushing against clothing, then suitable precautions shall be taken, e.g. the use of anti-static footwear.</p>														

ER Probe Reader (continued)

		IECEX Certificate of Conformity	
Certificate No.:	IECEX SIR 14.0094X	Issue No.:	0
Date of Issue:	2015-06-15	Page 4 of 4	
EQUIPMENT(continued):			
Conditions of manufacture			
The Manufacturer shall comply with the following:			
1.	The Reader-COT incorporates an IS Fusion Limited Type ISF021/TI/80 fuse that has previously been Ex Component certified under IECEX SIR 07.0050U. It is therefore the responsibility of the manufacturer to continually monitor the status of the certification associated with this device. The manufacturer shall inform CSA-Sira of any modifications to the device that may impinge upon the explosion safety design of the Reader-COT.		

LPR Probe Reader



IECEX Certificate of Conformity

INTERNATIONAL ELECTROTECHNICAL COMMISSION
IEC Certification Scheme for Explosive Atmospheres
for rules and details of the IECEx Scheme visit www.iecex.com

Certificate No.:	IECEX SIR 14.0095X	issue No.:	0	Certificate history:
Status:	Current			
Date of Issue:	2015-06-15	Page 1 of 3		
Applicant:	Rohrbach Cosasco Systems 11841 Smith Ave. Santa Fe Springs California 90670 United States of America			
Electrical Apparatus:	Reader-CAT			
Optional accessory:				
Type of Protection:	Intrinsically Safe			
Marking:	Ex ib IIC T4 Gb Tamb = -40°C To +70°C			
Approved for issue on behalf of the IECEx Certification Body:	C Ellaby			
Position:	Deputy Certification Manager			
Signature: (for printed version)	 _____			
Date:	2015-06-15 _____			

1. This certificate and schedule may only be reproduced in full.
 2. This certificate is not transferable and remains the property of the issuing body.
 3. The Status and authenticity of this certificate may be verified by visiting the [Official IECEx Website](http://www.iecex.com).

Certificate issued by:

SIRA Certification Service
 CSA Group
 Unit 6, Hawarden Industrial Park
 Hawarden
 Deeside
 CH5 3US
 United Kingdom



LPR Probe Reader (continued)

IEC		IECEX		IECEX Certificate of Conformity	
Certificate No.:	IECEX SIR 14.0095X			Issue No.:	0
Date of Issue:	2015-06-15			Page 2 of 3	
Manufacturer:	Rohrback Cosasco Systems 11841 Smith Ave. Santa Fe Springs California 90670 United States of America				
Additional Manufacturing location (s):					
<p>This certificate is issued as verification that a sample(s), representative of production, was assessed and tested and found to comply with the IEC Standard list below and that the manufacturer's quality system, relating to the Ex products covered by this certificate, was assessed and found to comply with the IECEX Quality system requirements. This certificate is granted subject to the conditions as set out in IECEX Scheme Rules, IECEX 02 and Operational Documents as amended.</p>					
STANDARDS:					
The electrical apparatus and any acceptable variations to it specified in the schedule of this certificate and the identified documents, was found to comply with the following standards:					
IEC 60079-0 : 2011	Explosive atmospheres - Part 0: General requirements				
Edition: 6.0					
IEC 60079-11 : 2011	Explosive atmospheres - Part 11: Equipment protection by intrinsic safety "I"				
Edition: 6.0					
<i>This Certificate does not indicate compliance with electrical safety and performance requirements other than those expressly included in the Standards listed above.</i>					
TEST & ASSESSMENT REPORTS:					
A sample(s) of the equipment listed has successfully met the examination and test requirements as recorded in					
<u>Test Report:</u>					
GB/SIR/ExTR15.0153/00					
<u>Quality Assessment Report:</u>					
US/UL/QAR08.0005/04					

LPR Probe Reader (continued)

		<h2 style="margin: 0;">IECEx Certificate of Conformity</h2>													
Certificate No.:	IECEx SIR 14.0095X		Issue No.: 0												
Date of Issue:	2015-06-15	Page 3 of 3													
Schedule															
EQUIPMENT:															
<i>Equipment and systems covered by this certificate are as follows:</i>															
<p>The Reader-CAT is 'carried by the person' equipment that is powered by two AA size replaceable primary cells located in a battery compartment. These cells may be replaced in the hazardous area. It consists of a plastic enclosure containing a p.c.b. assembly. One end of the enclosure is fitted with a membrane off/on switch and LED indicator. The other end of the enclosure is fitted with a connector intended to be connected to an external probe. The enclosure provides at least IP20 ingress protection.</p> <p>The intended use of the equipment is for the operator to carry the Reader-CAT to probes that are installed on plant and connect the Reader-CAT to these probes and then take a reading using a Mate, which is a separately certified (IECEx SIR 14.0096X) hand-held piece of equipment which communicates to the Reader-CAT via a wireless Bluetooth link.</p> <p>The Reader-CAT has the following parameters at the probe connector:</p> <table border="0" style="width: 100%; border-collapse: collapse;"> <tr> <td style="width: 25%;">U_i = 0</td> <td style="width: 25%;">U_o = 5.36V</td> <td style="width: 25%;">C_i = 0</td> <td style="width: 25%;">C_o = 65µF</td> </tr> <tr> <td>I_i = 0</td> <td>I_o = 67.2mA</td> <td>L_i = 35nH</td> <td>L_o = 7.87mH</td> </tr> <tr> <td>P_i = 0</td> <td>P_o = 90mW</td> <td></td> <td>Lo/Ro = 395µH/Ω</td> </tr> </table>				U _i = 0	U _o = 5.36V	C _i = 0	C _o = 65µF	I _i = 0	I _o = 67.2mA	L _i = 35nH	L _o = 7.87mH	P _i = 0	P _o = 90mW		Lo/Ro = 395µH/Ω
U _i = 0	U _o = 5.36V	C _i = 0	C _o = 65µF												
I _i = 0	I _o = 67.2mA	L _i = 35nH	L _o = 7.87mH												
P _i = 0	P _o = 90mW		Lo/Ro = 395µH/Ω												
Conditions of manufacture															
The Manufacturer shall comply with the following:															
<ol style="list-style-type: none"> 1. The Reader-CAT incorporates an IS Fusion Limited Type ISF021/T/80 fuse that has previously been Ex Component certified under IECEx SIR 07.0050U. It is therefore the responsibility of the manufacturer to continually monitor the status of the certification associated with this device. The manufacturer shall inform CSA-Sira of any modifications to the device that may impinge upon the explosion safety design of the Reader-CAT. 															
CONDITIONS OF CERTIFICATION: YES as shown below:															
<ol style="list-style-type: none"> 1. No precautions against electrostatic discharge are necessary for equipment carried by the person that has an enclosure made of plastic, metal or a combination of the two, except where a significant static-generating mechanism has been identified. Activities such as placing the item in a pocket or on a belt, operating a keypad or cleaning with a damp cloth, do not present a significant electrostatic risk. However, where a static-generating mechanism is identified, such as repeated brushing against clothing, then suitable precautions shall be taken, e.g. the use of anti-static footwear. 															

Legacy Converter



IECEX Certificate of Conformity

INTERNATIONAL ELECTROTECHNICAL COMMISSION
IEC Certification Scheme for Explosive Atmospheres
for rules and details of the IECEx Scheme visit www.iecex.com

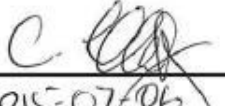
Certificate No.:	IECEX SIR 14.0097X	issue No.:0	<input style="width: 90%;" type="text" value="Certificate history:"/>
Status:	<input type="text" value="Current"/>		
Date of Issue:	2015-07-06	Page 1 of 4	
Applicant:	Rohrback Cosasco Systems 11841 Smith Ave. Santa Fe Springs California 90670 United States of America		
Electrical Apparatus:	Converter*		
Optional accessory:			
Type of Protection:	Intrinsically Safe		
Marking:	Ex ib IIC T4 Gb Ta = -40°C to +70°C		
Approved for issue on behalf of the IECEx Certification Body:	C Ellaby		
Position:	Deputy Certification Manager		
Signature: <small>(for printed version)</small>	 <hr style="width: 100%;"/>		
Date:	<hr style="width: 100%;"/> 2015-07-06		

1. This certificate and schedule may only be reproduced in full.
 2. This certificate is not transferable and remains the property of the issuing body.
 3. The Status and authenticity of this certificate may be verified by visiting the Official IECEx Website.

Certificate issued by:
SIRA Certification Service
 CSA Group
 Unit 6, Hawarden Industrial Park
 Hawarden
 Deeside
 CH5 3US
 United Kingdom



Legacy Converter (continued)

		<h2 style="text-align: center;">IECEX Certificate of Conformity</h2>	
Certificate No.:	IECEX SIR 14.0097X	Issue No.:	0
Date of Issue:	2015-07-06	Page 2 of 4	
Manufacturer:	Rohrbach Cosasco Systems 11841 Smith Ave. Santa Fe Springs California 90670 United States of America		
Additional Manufacturing location (s):			
<p>This certificate is issued as verification that a sample(s), representative of production, was assessed and tested and found to comply with the IEC Standard list below and that the manufacturer's quality system, relating to the Ex products covered by this certificate, was assessed and found to comply with the IECEx Quality system requirements. This certificate is granted subject to the conditions as set out in IECEx Scheme Rules, IECEx 02 and Operational Documents as amended.</p>			
<p>STANDARDS: The electrical apparatus and any acceptable variations to it specified in the schedule of this certificate and the identified documents, was found to comply with the following standards:</p>			
<p>IEC 60079-0 : 2011 Explosive atmospheres - Part 0: General requirements Edition: 6.0</p>			
<p>IEC 60079-11 : 2011 Explosive atmospheres - Part 11: Equipment protection by intrinsic safety 'I' Edition: 6.0</p>			
<p><i>This Certificate does not indicate compliance with electrical safety and performance requirements other than those expressly included in the Standards listed above.</i></p>			
<p>TEST & ASSESSMENT REPORTS: A sample(s) of the equipment listed has successfully met the examination and test requirements as recorded in</p>			
<p><u>Test Report:</u> GB/SIR/ExTR15.0176/00</p>			
<p><u>Quality Assessment Report:</u> US/UL/QAR08.0005/04</p>			

Legacy Converter (continued)

		<h2 style="margin: 0;">IECEx Certificate of Conformity</h2>	
Certificate No.:	IECEX SIR 14.0097X	Issue No.:	0
Date of Issue:	2015-07-06	Page 3 of 4	
Schedule			
EQUIPMENT:			
<i>Equipment and systems covered by this certificate are as follows:</i>			
<p>The Converter* is 'carried by the person' equipment that is powered by two AA size replaceable primary cells located in a battery compartment. These cells may be replaced in the hazardous area.</p> <p>It consists of a plastic enclosure containing a p.c.b. assembly. One end of the enclosure is fitted with an off/on switch and LED indicator. The other end of the enclosure is fitted with two 'RS 232' connectors (a 'LEMO' connector and an 'AMPHENOL' connector) that are internally connected in parallel and which are intended to be connected to equipment installed on plant. The enclosure provides at least IP20 ingress protection.</p> <p>The intended use of the equipment is for the operator to carry the Converter to the equipment installed on plant, connect the Converter to this equipment, and take a reading using a Mate, which is a separately-certified (Sira IECEx SIR 14.0096X) hand-held piece of equipment that communicates to the Converter via a wireless Bluetooth link.</p> <p>Conditions of manufacture</p> <p>The Manufacturer shall comply with the following:</p> <ol style="list-style-type: none"> The Converter* incorporates an IS Fusion Limited Type ISF021/T/80 fuse that has previously been Ex Component certified under IECEx SIR 07.0050U. It is therefore the responsibility of the manufacturer to continually monitor the status of the certification associated with this device. The manufacturer shall inform CSA-Sira of any modifications to the device that may impinge upon the explosion safety design of the Converter*. 			
CONDITIONS OF CERTIFICATION: YES as shown below:			
<ol style="list-style-type: none"> No precautions against electrostatic discharge are necessary for equipment carried by the person that has an enclosure made of plastic, metal or a combination of the two, except where a significant static-generating mechanism has been identified. Activities such as placing the item in a pocket or on a belt, operating a keypad or cleaning with a damp cloth, do not present a significant electrostatic risk. However, where a static-generating mechanism is identified, such as repeated brushing against clothing, then suitable precautions shall be taken, e.g. the use of anti-static footwear. 			

Legacy Converter (continued)



IECEx Certificate of Conformity

Certificate No.: **IECEx SIR 14.0097X**

Date of Issue: **2015-07-06**

Issue No.: **0**

Page 4 of 4

EQUIPMENT(continued):

The intrinsic safety parameters at the 'RS 232' connectors are as follows:

Tx and Rx pins combined w.r.t. GND pin:				
U _i = 11.1 V	I _i = n/a	P _i = n/a	C _i = 0	L _i = 35 nH
U _o = 11.1 V	I _o = 22.5 mA	P _o = 62.3 mW		
Tx pin w.r.t. Rx pin				
U _i = 22.2 V	I _i = n/a	P _i = n/a	C _i = 0	L _i = 35 nH
U _o = 22.2 V	I _o = 11.3 mA	P _o = 62.3 mW		

The load parameters are as follows:

Gas Group	Max. external capacitance (C _o)	Max. external inductance (L _o)	Max. external inductance to resistance ratio (L _o /R _o)
IIC	0.16 µF	70 mH	571 µH/Ω
IIB	1.11 µF	280 mH	2.28 mH/Ω
IIA	4.08 µF	560 mH	4.57 mH/Ω

ER Datalogger



IECEX Certificate of Conformity

INTERNATIONAL ELECTROTECHNICAL COMMISSION
IEC Certification Scheme for Explosive Atmospheres
for rules and details of the IECEx Scheme visit www.iecex.com

Certificate No.:	IECEX SIR 16.0009X	issue No.:0	Certificate history:
Status:	Current		
Date of Issue:	2016-02-03	Page 1 of 4	
Applicant:	<p>Rohrback Cosasco Systems 11841 Smith Ave. Santa Fe Springs California 90670 United States of America</p>		
Electrical Apparatus: Optional accessory:	RDC2-COT* and RDC2-COT-G*		
Type of Protection:	Intrinsically Safe		
Marking:	Ex ia IIC T4 Ga Tamb = -40°C to +70°C		
Approved for issue on behalf of the IECEx Certification Body:	C Ellaby		
Position:	Deputy Certification Manager		
Signature: (for printed version)			
Date:	<u>2016-02-03</u>		

1. This certificate and schedule may only be reproduced in full.
 2. This certificate is not transferable and remains the property of the issuing body.
 3. The Status and authenticity of this certificate may be verified by visiting the Official IECEx Website.

Certificate issued by:

SIRA Certification Service
CSA Group
 Unit 6, Hawarden Industrial Park
 Hawarden
 Deeside
 CH5 3US
 United Kingdom



ER Datalogger (continued)

		<h2>IECEX Certificate of Conformity</h2>	
Certificate No.:	IECEX SIR 16.0009X		
Date of issue:	2016-02-03	Issue No.:	0
			Page 2 of 4
Manufacturer:	Rohrback Cosasco Systems 11841 Smith Ave. Santa Fe Springs California 90670 United States of America		
Additional Manufacturing location (s):			
<p>This certificate is issued as verification that a sample(s), representative of production, was assessed and tested and found to comply with the IEC Standard list below and that the manufacturer's quality system, relating to the Ex products covered by this certificate, was assessed and found to comply with the IECEx Quality system requirements. This certificate is granted subject to the conditions as set out in IECEx Scheme Rules, IECEx 02 and Operational Documents as amended.</p>			
STANDARDS:			
The electrical apparatus and any acceptable variations to it specified in the schedule of this certificate and the identified documents, was found to comply with the following standards:			
IEC 60079-0 : 2011	Explosive atmospheres - Part 0: General requirements		
Edition: 6.0			
IEC 60079-11 : 2011	Explosive atmospheres - Part 11: Equipment protection by intrinsic safety "I"		
Edition: 6.0			
IEC 60079-26 : 2014-10	Explosive atmospheres - Part 26: Equipment with Equipment Protection Level (EPL) Ga		
Edition: 3.0			
<p><i>This Certificate does not indicate compliance with electrical safety and performance requirements other than those expressly included in the Standards listed above.</i></p>			
TEST & ASSESSMENT REPORTS:			
A sample(s) of the equipment listed has successfully met the examination and test requirements as recorded in			
<u>Test Report:</u>			
GB/SIR/EXTR16.0003/00			
<u>Quality Assessment Report:</u>			
US/UL/QAR08.0005/05			

ER Datalogger (continued)

		<h2 style="margin: 0;">IECEX Certificate of Conformity</h2>	
Certificate No.:	IECEX SIR 16.0009X	Issue No.:	0
Date of Issue:	2016-02-03	Page	3 of 4
Schedule			
EQUIPMENT:			
<i>Equipment and systems covered by this certificate are as follows:</i>			
<p>The RDC2-COT* and RDC2-COT-G* Data Loggers are fixed equipment and use an enclosure that is made from either fibreglass (with polyester mounts) or a stainless steel. The enclosure, which provides at least IP 20 ingress protection, contains a main p.c.b. assembly and an internal source of power, this source of power is an RCS RDC2 Battery Pack that incorporates two, D size, primary cells and is identified as part number 726043; a second, 'adapter' p.c.b. assembly may be mounted on the main p.c.b. The Battery Pack can only be replaced by another RCS RDC2 Pack but it can be changed even when an explosive atmosphere is present.</p> <p>One end of the enclosure has a permanently connected cable that enters the enclosure via a cable gland, the intention being that the cable is connected to an RCS/Cosasco simple apparatus probe (not covered by this certification). This end of the enclosure is also fitted with a vent/drain. The other end of the enclosure may have up to two, RF coaxial connector/adapters fitted, these are connected to an external antenna by the user.</p> <p>It is intended that an operator takes a reading from the RDC2-COT* or RDC2-COT-G* using a Mate, which is a separately certified (IECEX SIR 14.0096X), hand-held, piece of equipment, or other suitably certified hand-held equipment (including a phone) running RCS application software; the two devices communicate via a wireless, Bluetooth link.</p> <p>Refer to EQUIPMENT (continued) for additional information</p>			
CONDITIONS OF CERTIFICATION: YES as shown below:			
<ol style="list-style-type: none"> 1. Under certain extreme circumstances, the exposed plastic/fibre glass surfaces of the non-metallic enclosure version of the equipment may generate, and its unearthed metal parts may store, an ignition-capable level of electrostatic charge. Therefore this version of the equipment shall not be installed in a location where the external conditions are conducive to the build-up of electrostatic charge on the enclosure surfaces. In addition, the equipment shall only be cleaned with a damp cloth. This is particularly important if the equipment is installed in a Zone 0 location. 2. The maximum radio power output at the RF connectors is 1W. Any antenna fitted shall not result in the radiated power exceeding 2 W when any antenna gain is taken into account. 3. The RDC2-COT-G* version of the equipment is not capable of passing a 500 V dielectric strength test, according to Clause 6.3.13 of IEC 60079-11, between its intrinsically safe circuits and its enclosure. This shall be taken into account in any equipment installation. 			

ER Datalogger (continued)

		<h2 style="margin: 0;">IECEX Certificate of Conformity</h2>	
Certificate No.:	IECEX SIR 16.0009X		
Date of Issue:	2016-02-03	Issue No.:	0
			Page 4 of 4
EQUIPMENT(continued):			
The intrinsic safety parameters at the permanently connected cable are:			
$U_i = 0$	$i_i = 0$	$P_i = 0$	
$U_o = 5.36 \text{ V}$	$i_o = 0.329 \text{ A}$	$P_o = 0.45 \text{ W}$	$C_o = 64.9 \mu\text{F}$ $L_o = 300 \mu\text{H}$ $L_o/R_o = 53 \mu\text{H}/\Omega$
The intrinsic safety parameters at the RF coaxial connectors are:			
$U_i = 0$	$i_i = 0$	$P_i = 0$	$C_i = 30.4 \mu\text{F}$ $L_i = 35 \text{ nH}$
$U_o = 5.36 \text{ V}$	$i_o = 0.894 \text{ A}$	$P_o = 0.95 \text{ W}$	$C_o = 1.6 \mu\text{F}$ $L_o = 44.4 \mu\text{H}$ (A max. of 2 μH shall be discrete inductance, the balance being allowed as cable inductance)
Conditions of manufacture			
The Manufacturer shall comply with the following:			
1.	The RDC2-COT* and RDC2-COT-G* incorporates an IS Fusion Limited Type ISF021/T/80 fuse that has previously been Ex Component certified under IECEx SIR 07.0050U. It is therefore the responsibility of the manufacturer to continually monitor the status of the certification associated with this device. The manufacturer shall inform CSA-Sira of any modifications to the device that may impinge upon the explosion safety design of the RDC2-COT* and RDC2-COT-G*.		

LPR Datalogger

		<h2>IECEX Certificate of Conformity</h2>	
<p>INTERNATIONAL ELECTROTECHNICAL COMMISSION IEC Certification Scheme for Explosive Atmospheres <small>for rules and details of the IECEx Scheme visit www.iecex.com</small></p>			
Certificate No.:	IECEX SIR 16.0010X	issue No.:	0
Status:	Current		
Date of Issue:	2016-02-03	Page 1 of 4	
Applicant:	Rohrback Cosasco Systems 11841 Smith Ave. Santa Fe Springs California 90670 United States of America		
Electrical Apparatus:	RDC2-CAT* and RDC2-CAT-G*		
Optional accessory:			
Type of Protection:	Intrinsically Safe		
Marking:	Ex ia IIC T4 Ga Tamb = -40°C to +70°C		
Approved for issue on behalf of the IECEx Certification Body:	C Ellaby		
Position:	Deputy Certification Manager		
Signature: (for printed version)			
Date:			
<p>1. This certificate and schedule may only be reproduced in full. 2. This certificate is not transferable and remains the property of the issuing body. 3. The Status and authenticity of this certificate may be verified by visiting the Official IECEx Website.</p>			
<p>Certificate issued by:</p> <p>SIRA Certification Service CSA Group Unit 6, Hawarden Industrial Park Hawarden Deeside CH5 3US United Kingdom</p>			
			

LPR Datalogger (continued)

		<h2 style="text-align: center;">IECEX Certificate of Conformity</h2>	
Certificate No.:	IECEX SIR 16.0010X	Issue No.:	0
Date of Issue:	2016-02-03	Page 2 of 4	
Manufacturer:	Rohrback Cosasco Systems 11841 Smith Ave. Santa Fe Springs California 90670 United States of America		
Additional Manufacturing location (s):			
<p>This certificate is issued as verification that a sample(s), representative of production, was assessed and tested and found to comply with the IEC Standard list below and that the manufacturer's quality system, relating to the Ex products covered by this certificate, was assessed and found to comply with the IECEx Quality system requirements. This certificate is granted subject to the conditions as set out in IECEx Scheme Rules, IECEx 02 and Operational Documents as amended.</p>			
STANDARDS:			
The electrical apparatus and any acceptable variations to it specified in the schedule of this certificate and the identified documents, was found to comply with the following standards:			
IEC 60079-0 : 2011 Edition: 6.0	Explosive atmospheres - Part 0: General requirements		
IEC 60079-11 : 2011 Edition: 6.0	Explosive atmospheres - Part 11: Equipment protection by intrinsic safety "I"		
IEC 60079-26 : 2014-10 Edition: 3.0	Explosive atmospheres - Part 26: Equipment with Equipment Protection Level (EPL) Ga		
<p><i>This Certificate does not indicate compliance with electrical safety and performance requirements other than those expressly included in the Standards listed above.</i></p>			
TEST & ASSESSMENT REPORTS:			
A sample(s) of the equipment listed has successfully met the examination and test requirements as recorded in			
<u>Test Report:</u>			
GB/SIR/ExTR16.0004/00			
<u>Quality Assessment Report:</u>			
US/UL/QAR08.0005/05			

LPR Datalogger (continued)

		<h2 style="margin: 0;">IECEx Certificate of Conformity</h2>	
Certificate No.:	IECEx SIR 16.0010X	Issue No.:	0
Date of Issue:	2016-02-03	Page 3 of 4	
Schedule			
EQUIPMENT:			
<i>Equipment and systems covered by this certificate are as follows:</i>			
<p>The RDC2-CAT* and RDC2-CAT-G* are fixed equipment and use an enclosure that is made from either fibreglass (with polyester mounts) or a stainless steel. The enclosure, which provides at least IP 20 ingress protection, contains a main p.c.b. assembly and an internal source of power, this source of power is an RCS RDC2 Battery Pack that incorporates two, D size, primary cells and is identified as part number 726043; a second, 'adapter' p.c.b. assembly may be mounted on the main p.c.b. The Battery Pack can only be replaced by another RCS RDC2 Pack but it can be changed even when an explosive atmosphere is present.</p> <p>One end of the enclosure has a permanently connected cable that enters the enclosure via a cable gland, the intension being that the cable is connected to an RCS/Cosasco simple apparatus probe (not covered by this certification). This end of the enclosure is also fitted with a vent/drain. The other end of the enclosure may have up to two, RF coaxial connector/adapters fitted, these are connected to an external antenna by the user.</p> <p>It is intended that an operator takes a reading from the RDC2-CAT* or RDC2-CAT-G* using a Mate, which is a separately certified (IECEx SIR 14.0096X), hand-held, piece of equipment; or other suitably certified hand-held equipment (including a phone) running RCS application software; the two devices communicate via a wireless, Bluetooth link.</p> <p>Refer to EQUIPMENT (continued) for additional information</p>			
CONDITIONS OF CERTIFICATION: YES as shown below:			
<ol style="list-style-type: none"> 1. Under certain extreme circumstances, the exposed plastic/fibre glass surfaces of the non-metallic enclosure version of the equipment may generate, and its unearthed metal parts may store, an ignition-capable level of electrostatic charge. Therefore this version of the equipment shall not be installed in a location where the external conditions are conducive to the build-up of electrostatic charge on the enclosure surfaces. In addition, the equipment shall only be cleaned with a damp cloth. This is particularly important if the equipment is installed in a Zone 0 location. 2. The maximum radio power output at the RF connectors is 1 W. Any antenna fitted shall not result in the radiated power exceeding 2 W when any antenna gain is taken into account. 3. The RDC2-CAT-G* version of the equipment is not capable of passing a 500 V dielectric strength test, according to Clause 6.3.13 of IEC 60079-11:2011, between its intrinsically safe circuits and its enclosure. This shall be taken into account in any equipment installation. 			

LPR Datalogger (continued)



IECEX Certificate of Conformity

Certificate No.: **IECEX SIR 16.0010X**

Date of Issue: **2016-02-03** Issue No.: **0**

Page 4 of 4

EQUIPMENT(continued):

The intrinsic safety parameters at the permanently connected cable are:
 $U_i = 0$ $I_i = 0$ $P_i = 0$
 $U_o = 5.36V$ $I_o = 67.2mA$ $P_o = 90mW$ $C_o = 64.9\mu F$ $L_o = 300\mu H$ $L_o/R_o = 390\mu H/\Omega$

The intrinsic safety parameters at the RF connectors are:
 $U_i = 0$ $I_i = 0$ $P_i = 0$ $C_i = 29.24\mu F$ $L_i = 35nH$
 $U_o = 5.36V$ $I_o = 0.938A$ $P_o = 0.95W$ $C_o = 760nF$ $L_o = 40.3\mu H^*$



* A maximum of 2 μH shall be discrete inductance, the balance being permitted to be cable inductance.

Conditions of manufacture
 The Manufacturer shall comply with the following:

1. The RDC2-CAT* and RDC2-CAT-G* incorporates an IS Fusion Limited Type ISF021/T/80 fuse that has previously been Ex Component certified under IECEx SIR 07.0050U. It is therefore the responsibility of the manufacturer to continually monitor the status of the certification associated with this device. The manufacturer shall inform CSA-Sira of any modifications to the device that may impinge upon the explosion safety design of the RDC2-CAT* and RDC2-CAT-G*.

M-200

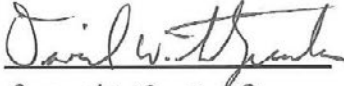
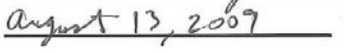
The M-200 uses the same certifications as the MWT-3905.

		<h2 style="margin: 0;">IECEX Certificate of Conformity</h2>	
<p>INTERNATIONAL ELECTROTECHNICAL COMMISSION IEC Certification Scheme for Explosive Atmospheres <small>for rules and details of the IECEx Scheme visit www.iecex.com</small></p>			
Certificate No.:	IECEX FMG 09.0004	issue No.: 0	Certificate history:
Status:	Current		
Date of Issue:	2009-08-13	Page 1 of 3	
Applicant:	Rohrback Cosasco Systems 11841 East Smith Ave Santa Fe Springs, CA 90670 United States of America		
Electrical Apparatus:	MWT-3905		
<i>Optional accessory:</i>			
Type of Protection:	d [ib]		
Marking:	Ex d [ib] IIC		
<i>Approved for issue on behalf of the IECEx Certification Body:</i>	David Styrcula		
<i>Position:</i>	Technical Team Manager		
<i>Signature:</i> <i>(for printed version)</i>			
<i>Date:</i>			
1. This certificate and schedule may only be reproduced in full. 2. This certificate is not transferable and remains the property of the issuing body. 3. The Status and authenticity of this certificate may be verified by visiting the Official IECEx Website .			
Certificate issued by:			
FM Approvals LLC 1151 Boston-Providence Turnpike Norwood, MA 02062 United States of America			

M-200 (continued)

		<h2 style="margin: 0;">IECEX Certificate of Conformity</h2>	
Certificate No.:	IECEX FMG 09.0004	Issue No.:	0
Date of Issue:	2009-08-13	Page 2 of 3	
Manufacturer:	Rohrback Cosasco Systems 11841 East Smith Ave Santa Fe Springs, CA 90670 United States of America		
Manufacturing location(s):	<p>This certificate is issued as verification that a sample(s), representative of production, was assessed and tested and found to comply with the IEC Standard list below and that the manufacturer's quality system, relating to the Ex products covered by this certificate, was assessed and found to comply with the IECEx Quality system requirements. This certificate is granted subject to the conditions as set out in IECEx Scheme Rules, IECEx 02 and Operational Documents as amended.</p>		
STANDARDS:	<p>The electrical apparatus and any acceptable variations to it specified in the schedule of this certificate and the identified documents, was found to comply with the following standards:</p>		
IEC 60079-0 : 2007-10	Explosive atmospheres - Part 0: Equipment - General requirements		
Edition: 5			
IEC 60079-1 : 2007-04	Explosive atmospheres - Part 1: Equipment protection by flameproof enclosures "d"		
Edition: 6			
IEC 60079-11 : 2006	Explosive atmospheres - Part 11: Equipment protection by intrinsic safety "i"		
Edition: 5			
<p><i>This Certificate does not indicate compliance with electrical safety and performance requirements other than those expressly included in the Standards listed above.</i></p>			
TEST & ASSESSMENT REPORTS:	<p>A sample(s) of the equipment listed has successfully met the examination and test requirements as recorded in</p>		
<u>Test Report:</u>			
US/FMG/ExTR09.0006/00			
<u>Quality Assessment Report:</u>			
US/UL/QAR08.0005/00			
US/UL/QAR08.0005/01			

M-200 (continued)

		IECEX Certificate of Conformity	
Certificate No.:	IECEX FMG 09.0004	Issue No.:	0
Date of Issue:	2009-08-13	Page 3 of 3	
Schedule			
EQUIPMENT: <i>Equipment and systems covered by this certificate are as follows:</i>			
MWT-3905			
CONDITIONS OF CERTIFICATION: NO			

Appendix D

Drawing 726061

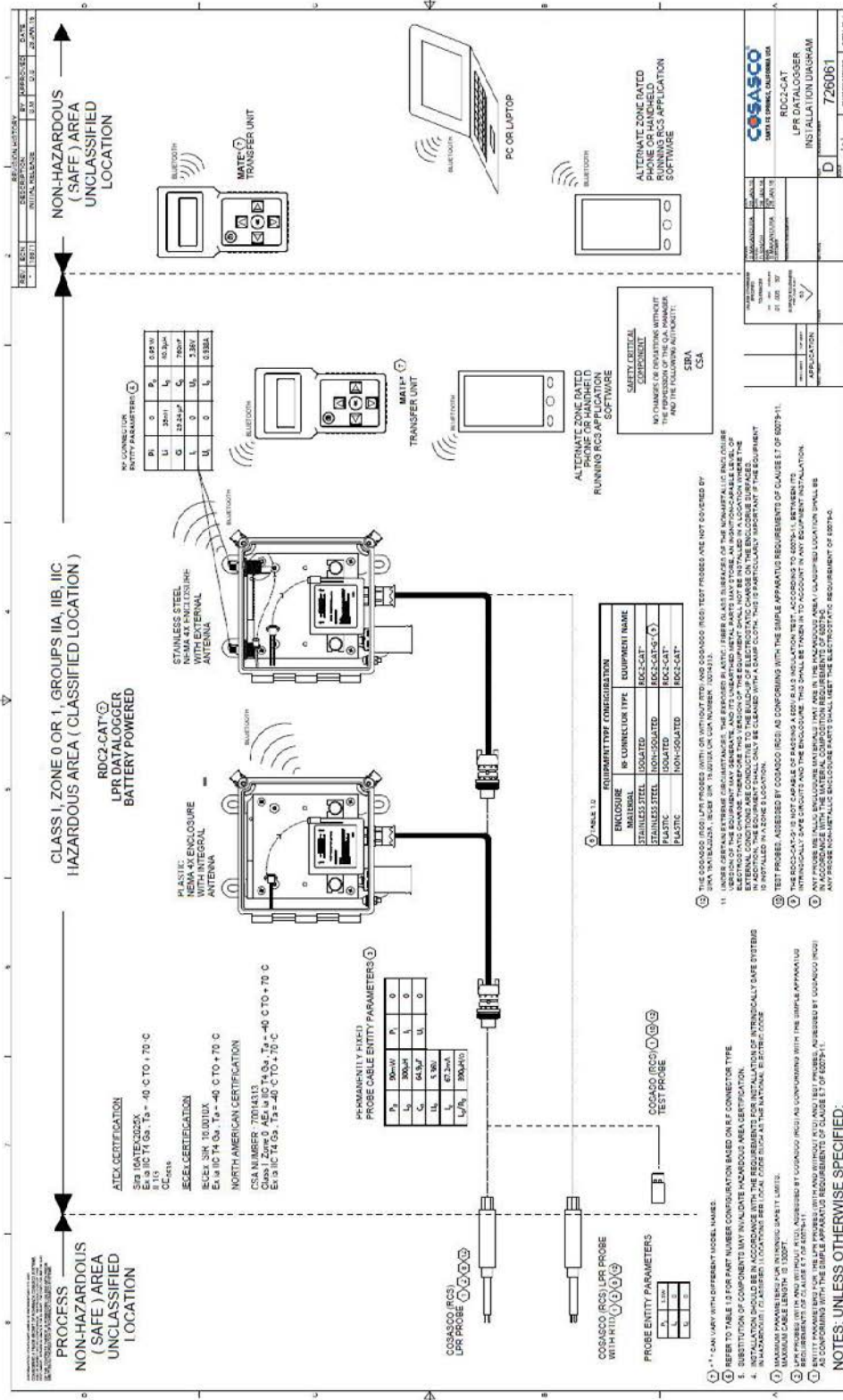

Drawing 702408

REV.	CON.	DESCRIPTION	BY	APP'D	DATE
1		INITIAL RELEASE	R.P. J.B.S.		
2		ISSUED FOR FM	R.P. J.B.S.		
3		ISSUED FOR FM	R.P. J.B.S.		
4		ISSUED FOR FM	R.P. J.B.S.		

EUROPEAN UNION (EU) ATEX CERTIFICATION
 FM 09 ATEX 0018X
 Ex d [ib] CLASS I, ZONE 1, IIC, T4, T5 = -40C TO +70C

NORTH AMERICAN CERTIFICATION
 FM AEx d [ib] CLASS I, ZONE 1, IIC, T4, T5 = -40C TO +70C
 FMEx d [ib] CLASS I, ZONE 1, IIC, T4, T5 = -40C TO +70C

IEC EX CERTIFICATION
 IEC Ex d [ib] CLASS I, ZONE 1, IIC, T4, T5 = -40C TO +70C
 IEC Ex d [ib] CLASS I, ZONE 1, IIC, T4, T5 = -40C TO +70C

MWC-3905
ENCLOSURE IP68
FOR USE ONLY WITH POWER MODULE P/N 748400

COMMUNICATION PORT CONNECTOR

PROBE PORT CONNECTOR

COMMUNICATION PORT CONNECTOR ENTITY PARAMETERS

95-232

OTHER PN 2 TO PN 5 OR PN 3 TO PN 5

$U_p = 11.1 \text{ V}$	$I_p = 25.9 \text{ mA}$	$U_i = 11.1 \text{ V}$	$I_i = 58.1 \text{ mA}$
$P_p = 31.7 \text{ mW}$	$P_i = 288 \text{ mW}$	$P_o = 155.6 \text{ mW}$	$I_o = 58.1 \text{ mA}$
$C_p = 8.1 \mu\text{F}$	$C_i = 0$	$C_o = 11.3 \text{ mH}$	$C_l = 0$
$L_p = 283.5 \text{ mH}$	$L_i = 0$	$L_o = 11.3 \text{ mH}$	$L_l = 0$

$\frac{1}{R} = 228 \frac{\mu\text{S}}{\text{ohm}}$

PROBE PORT CONNECTOR ENTITY PARAMETERS

$U_p = 1.25 \text{ V}$	$I_p = 0.73 \text{ A}$	$U_i = 1.4 \text{ V}$	$I_i = 0.3 \text{ V}$
$P_p = 3.16 \text{ W}$	$P_i = 1.83 \text{ A}$	$I_o = 7.9 \text{ mA}$	$I_l = 0.59 \text{ A}$
$P_o = 0.99 \text{ W}$	$P_l = 5.6 \text{ W}$	$P_p = 15.4 \text{ mW}$	$P_i = 166 \text{ mW}$
$C_p = 100 \mu\text{F}$	$C_i = 0$	$C_o = 100 \mu\text{F}$	$C_l = 0$
$L_p = 5 \mu\text{H}$	$L_i = 0$	$L_o = 137 \text{ H}$	$L_l = 0$

$\frac{1}{R} = 35.4 \frac{\mu\text{S}}{\text{ohm}}$

CONNECT TO ROHRBACK RESISTANCE PROBES (ONLY)

SAFETY CRITICAL

NO CHANGES OR MODIFICATIONS WITHOUT THE FOLLOWING APPROVALS AND THE FOLLOWING CAUTIONS:

FM APPROVALS

ROHRBACK COSASCO SYSTEMS

INSTALLATION DRAWING

MWT-3905

INTRINSIC SAFETY

702408

3. WARNING: SUBSTITUTION OF COMPONENTS MAY IMPAIR INTRINSIC SAFETY.

2. INSTALLATION SHOULD BE IN ACCORDANCE WITH THE REQUIREMENTS FOR LOCATIONS FOR LOCAL CODE SUCH AS THE NATIONAL ELECTRIC CODE (ANSI/NFPA70).

1. THE ENTITY CONCEPT ALLOWS INTERCONNECTION OF INTRINSICALLY SAFE APPARATUS WITH ASSOCIATED APPARATUS WHERE THE FOLLOWING IS TRUE:

$U_p \leq U_i$
 $I_p \leq I_i$
 $P_o \leq P_l + C_{cable}$
 $C_p \leq C_i + C_{cable}$
 $L_p \geq L_i + L_{cable}$ OR $CABLE \leq \frac{1}{R}$

NOTES: UNLESS OTHERWISE SPECIFIED: