

PORCEA STONE DOES NOT TAKE RESPONSIBILITY FOR IMPROPER INSTALLATION. THE INFORMATION IN THIS GUIDE IS PURELY INDICATIVE AND CONDITIONS WILL VARY FROM SITE TO SITE. PLEASE ALWAYS CONSULT WITH PROFESSIONAL INSTALLERS TO PROVIDE SPECIFIC GUIDANCE ON YOUR PROJECT.



Authorized Distributor



INSTALLATION MANUAL

- LAYING ON SCREED WITH GLUE
- LAYING ON WET SAND WITH CEMENT
- RAISED LAYING WITH SUPPORTS
- LAYING ON GRAVEL
- LAYING ON SAND
- LAYING ON GRASS



LEADERS IN OUTDOOR PORCELAIN

PORCEA STONE



DRIVE-OVER

LAYING ON SCREED WITH ADHESIVE



The advanced technical features of the 2 cm (3/4")-thick PORCEA STONE collections, combined with an adhesive laying technique on screed, allow users to create perfectly stable and exceptionally hard-wearing surfaces. PORCEA STONE slabs used with this solution can withstand both moving and parked vehicles. Ideal for heavily frequented areas, in particular for squares, pavements, or ramps.

ADVANTAGES:

- Maximum stability over time
- Ideal for areas open to vehicle traffic
- Ideal for areas frequented by large numbers of pedestrians

INTENDED USE:

- Driveways
- Pool sides
- Terraces
- Car parking
- Residential areas
- Commercial areas
- Outdoor stairs
- Garage ramps

Expansion joints are necessary and joints must be filled with cementitious grout.



INSTALLATION

EXAMPLE OF LAYING ON GROUND

- A PORCEA STONE slabs
- B Concrete screed (may include electro welded mesh) Ensure 2% slope.
- C Reinforcement layer
- D Concrete screed
- E Loose stone foundation (gravel)
- F Soil

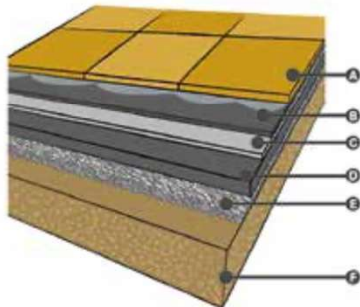

The proposed diagrams and indications are purely indicative of the type of application: please refer to the specific regulations in force in your country in order to lay the floor to the highest technical standards.

WHAT YOU NEED:

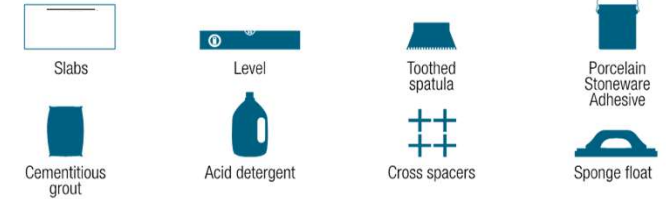

INSTRUCTIONS:

Recommended Adhesives: Mapei or Laticrete

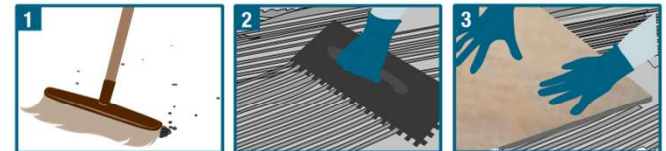

1 Realize a state of art screed and clean the residues.

2 Spread the adhesive homogeneously.

3 Slabs must adhere to the adhesive layer.



4 Use the cross spacers to assure an equal joint.

5 Once the laying is complete, proceed with the grouting.

6 Clean with a water and buffered acid solution to remove residues.

LEADERS IN OUTDOOR PORCELAIN

**PORCEA
STONE**

LAYING ON WET SAND WITH CEMENT

COMMERCIAL-GRADE
WITH 2 CM OR 3 CM

The slabs are laid on a base of sand mixed with cement. This technique guarantees the slabs long term stability and their vehicle accessibility. It also allows to lay the slabs straight on the floor screed avoiding the high costs of the levelling screed arrangements.



ADVANTAGES:

- Maximum stability over time
- Ideal for areas open to vehicle traffic
- Ideal for areas frequented by large numbers of pedestrians

INTENDED USE:

- Driveways
- Pool sides
- Terraces
- Car parking
- Residential areas
- Commercial areas
- Outdoor stairs
- Garage ramps

WHAT YOU NEED:



INSTRUCTIONS:

Recommended Adhesives: Mapei or Laticrete



1 Prepare the mixture of sand and cement in the concrete mixer, two parts of cement by weight per ten parts of sand. Cement and water in equal parts.

2 Lay the mixture over the existing screed and level it guaranteeing a slope of at least 2%. The layer thickness must be between 5 to 7 cm (2"- 3") to guarantee drive-over.

3 Spread the adhesive for porcelain stoneware on the back of the slabs.

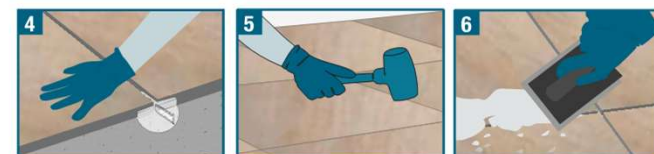

4 Lay the slabs with the aid of the Crocette cross spacers.

5 Use the rubber mallet to level the slabs.

6 Once the laying is complete, proceed with the grouting.



DRIVE-OVER

Expansion joints are necessary and joints must be filled with cementitious grout.

INSTALLATION

EXAMPLE OF LAYING ON SCREED

- A PORCEA STONE slabs
- B Adhesive for porcelain stoneware
- C Sand with cement levelling screed
- D Floor screed

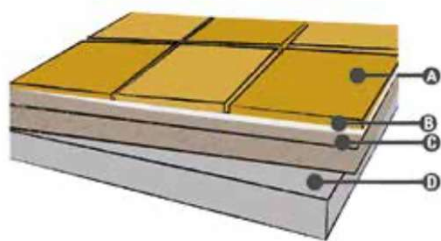

The proposed diagrams and indications are purely indicative of the type of application: please refer to the specific regulations in force in your country in order to lay the floor to the highest technical standards.

LEADERS IN OUTDOOR PORCELAIN

PORCEA STONE

RAISED LAYING WITH SUPPORT



Floating paving is composed by a series of modular and adjustable supports, that easily and safely adapt to all paving types. Designed to guarantee an homogeneous surface, without bringing radical changes to the existing structure, as well as to eliminate humidity problems, water infiltrations, passage of electric cables and pipes, floating paving solutions allow easy and quick inspections and rainwater efficient drainage.

INTENDED USE:

- Residential areas
- Commercial areas
- Terraces
- Garden, courtyard or patio



INSTALLATION

EXAMPLE OF RAISED LAYING

- A PORCEA STONE slabs
- B Adjustable/fixed supports
- C Waterproof sheath
- D Screed with maximum slope of 5%

TRAY SYSTEMS MAY BE REQUIRED FOR 20 MM OR 30 MM PORCEA STONE INSTALLED ON PEDESTALS. ALWAYS CONSULT WITH THE LANDSCAPE ARCHITECT & ENGINEERING CONSULTANT FOR SITE-SPECIFIC GUIDANCE.

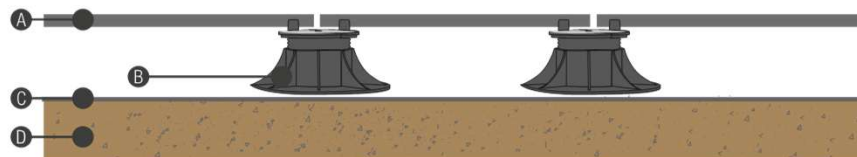

For a vertical application with pedestals, metal clips can be utilized along with cutting the Porcea Stone slabs into risers that can be clamped onto the system.

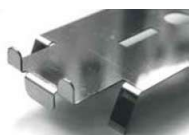

WHAT YOU NEED:

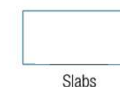

Slabs



Level



Support



Adjusting key

INSTRUCTIONS:



1 Realize a state of art screed and clean the residues.



2 Place the supports in relation to the dimensions of the used tile.

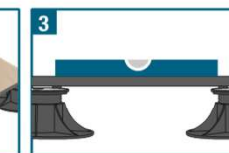

3 Verify the proper levelling of the laid slabs (slope $\geq 1\%$).

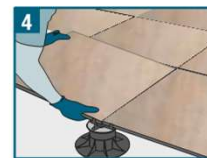

4 When laying, check that the joint width is always constant.

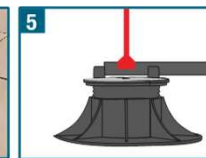

5 Finished the laying, adjust the supports height with the adjusting key.



Installation Guidelines: Porcea Pedestals & Porcea Spacers

TRAY SYSTEMS MAY BE REQUIRED FOR 20 MM OR 30 MM PORCEA STONE INSTALLED ON PEDESTALS. ALWAYS CONSULT WITH THE LANDSCAPE ARCHITECT & ENGINEERING CONSULTANT FOR SITE-SPECIFIC GUIDANCE.

PORCEA STONE

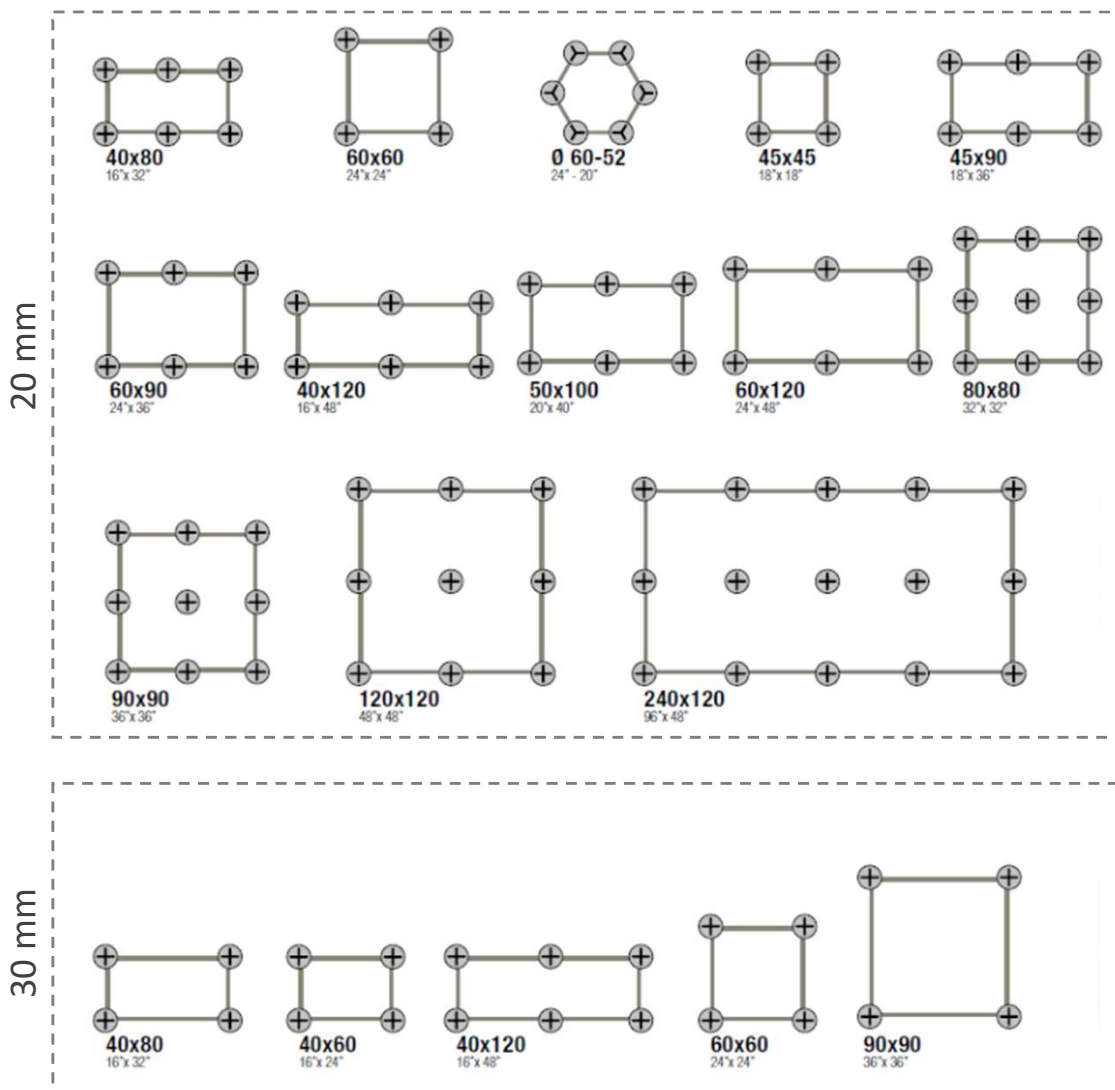

THICKNESS	SIZE	PEDESTALS/M ²	PEDESTALS/SLAB
1,8 CM	45x45 CM	4,94	1
2 CM	60x60 CM	2,78	1
2 CM	40x80 CM	6,25	2
2 CM	45x90 CM	4,94	2
2 CM	40x120 CM	4,17	2
2 CM	50x100 CM	4,00	2
2 CM	60x90 CM	3,70	2
2 CM	60x120 CM	2,78	2
2 CM	80x80 CM	6,25	4
2 CM	90x90 CM	4,94	4
2 CM	120x120 CM	2,78	4
2 CM	120x240 CM	2,78	8
2 CM	ESAGONO Ø 60-52 CM	8,70	2
3 CM	60x60 CM	2,78	1
3 CM	40x60 CM	4,17	1
3 CM	40x80 CM	3,13	1
3 CM	40x120 CM	4,17	2
3 CM	90x90 CM	1,23	1

Note: This information is indicative only. Please consult an certified engineer for rooftop, commercial, or high-traffic applications of Porcea Stone products.

LEADERS IN OUTDOOR PORCELAIN



LAYING ON GRAVEL

This system is particularly recommended in areas where drainage of the water in the underlying soil is a problem, and also for concrete floor screeds, such as on balconies or terraces. The slabs can be laid dry by simply placing them on top of the previously prepared gravel base, without the need of porcelain stoneware adhesives. This means the slabs are easily levelled out on top of the gravel and are ready for use immediately afterwards.

INTENDED USE:

- Residential areas
- Footpaths
- Terraces
- Garden, courtyard or patio

INSTALLATION

EXAMPLE OF LAYING ON GROUND

- A PORCEA STONE slabs
- B Gravel
- C Non-woven fabric
- D Drainage layer
- E Soil

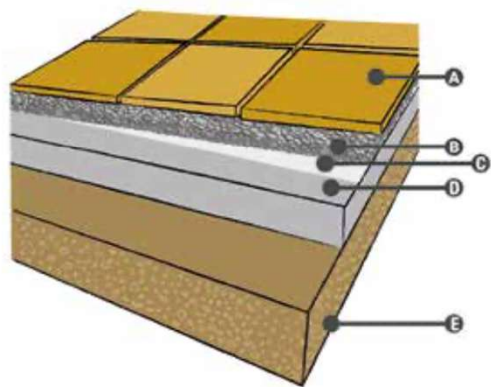

EXAMPLE OF LAYING ON FLAT COVERING

- A PORCEA STONE slabs
- B Ballast layer of gravel
- C Separation layer
- D Thermal insulation element
- E Vapour barrier
- F Waterproof layer
- G Sloping screed
- H Floor

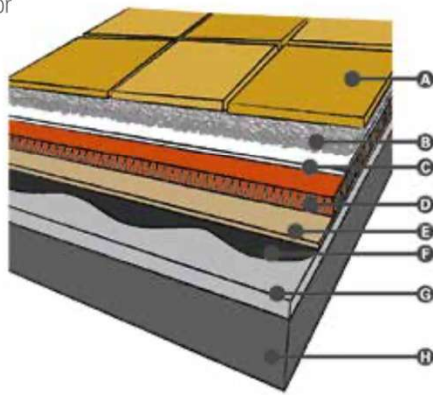

The proposed diagrams and indications are purely indicative of the type of application: please refer to the specific regulations in force in your country in order to lay the floor to the highest technical standards.



WHAT YOU NEED:

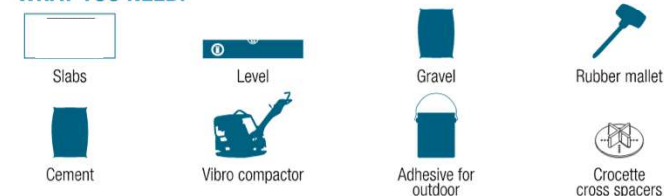

INSTRUCTIONS:

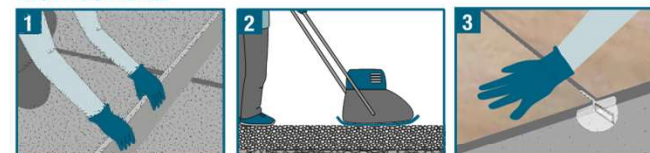

1 Over the non-woven fabric or the separation layer, lay the gravel (10/30 cm 4"-12"). To give more stability can be added a binder.

2 Level the soil with the aid of a vibro compactor, to guarantee stability over the time. A slope of at least 2% is needed to ensure the right water drainage.

3 Lay the slabs with the aid of the Crocette cross spacers.

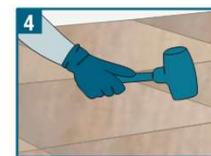

4 Use the rubber mallet to level the slabs.



5 Once the laying is complete, proceed with the grouting.

LEADERS IN OUTDOOR PORCELAIN

PORCEA STONE

LAYING ON SAND

TYPICALLY FOR WARMER CLIMATES SUCH AS FLORIDA, TEXAS AND CALIFORNIA



The slabs can be laid dry by simply placing them in the desired position, without the need adhesives. This means the slabs are easily levelled out on top of the sand and are ready for use immediately afterwards. This allows users to change the paving at any time or reuse the same material several times, even in different locations.

INTENDED USE:

- Residential areas
- Footpaths
- Terraces
- Garden, courtyard or patio



WHAT YOU NEED:

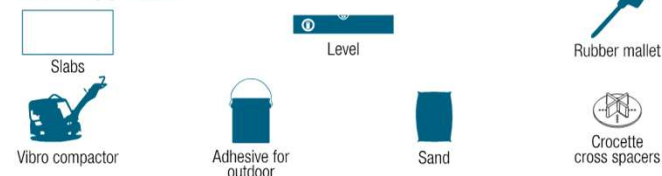

INSTRUCTIONS:

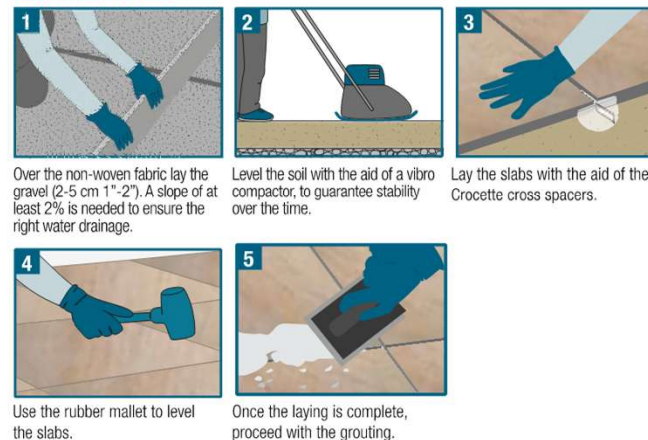

INSTALLATION

EXAMPLE OF LAYING ON GROUND

- A PORCEA STONE slabs
- B Sand
- C Non-woven fabric
- D Drainage layer
- E Soil

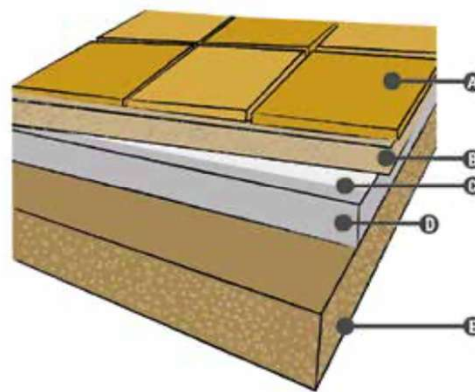

LAYING ON GRASS

Where there are lawns slabs can be dry laid on top of grass without using any adhesives. This allows users to change the paving at any time and reuse the same material several times.

Dry-laying does not require specialized installers and the slabs are ready for use as soon as the job is finished.

INTENDED USE:

- Residential areas
- Footpaths
- Gazebo
- Garden, courtyard or patio



INSTRUCTIONS:

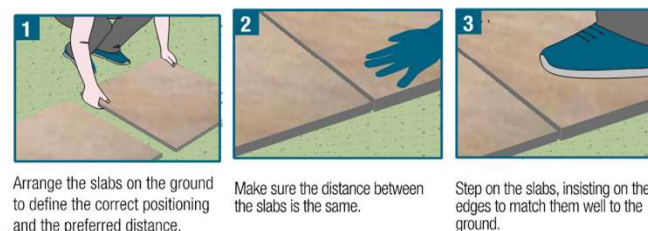

The proposed diagrams and indications are purely indicative of the type of application; please refer to the specific regulations in force in your country in order to lay the floor to the highest technical standards.

LEADERS IN OUTDOOR PORCELAIN



VENTILATED FACADES

ADVANTAGES - VANTAGGI - VORTEILE - AVANTAGES



ENERGY SAVING



THERMAL COMFORT



SELF-CLEANING



TECHNICAL PERFORMANCE



WEATHER-RESISTANT



IDEAL FOR RENOVATIONS



VENTILATED FAÇADES, KERF SYSTEM

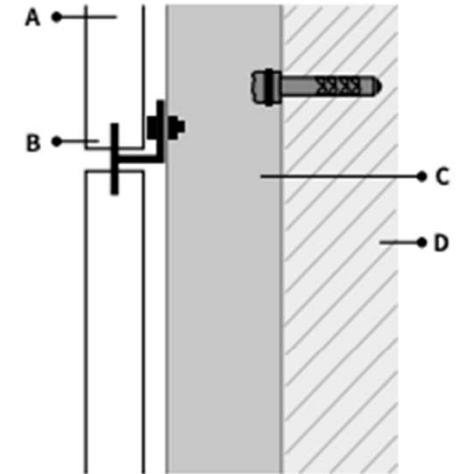
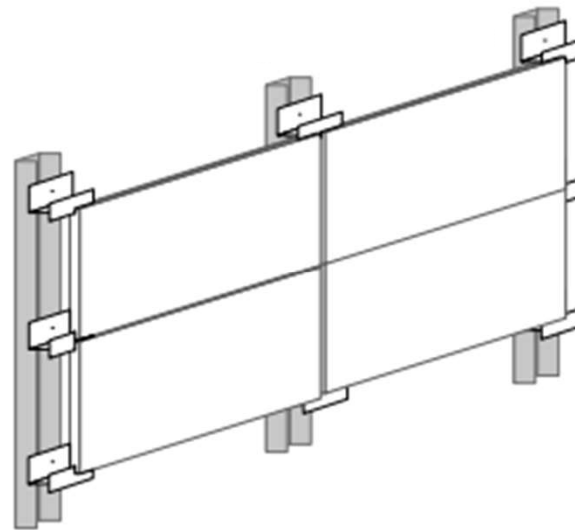

- A: Slab - Lastra - Platte - Dalle
- B: Bracket - Staffa - Klammer - Support
- C: Structure - Struttura - Struktur - Structure
- D: Wall - Muro - Wand - Mur

The KERF technology applied to the 2 cm slabs allows the cladding to be anchored in total safety by means of brackets that allow the upper slab to be supported and prevent the one below from overturning. In addition to the obvious functional advantages, it allows to contain costs and guarantees greater impact resistance than other systems. Maximum recommended size 120x120x2 cm.



RECOMMENDED MORTARS AND GROUT

Grout / joints: Mapei Ultra Colour Plus Max, Mapei Ultra Colour Plus FA Laticrete Permacolor - this is a fast-setting product so in the summer, it is recommended that you mix with colder water and cover the job site with the tarp to prevent the sun from beating down on it. All adhesives must be applied with min. temperature of +5°C. For 30 mm porcelain pavers, it is recommended to use polymeric sand or use backer rods as grout may not reach the bottom. Dynacolor 2000 Portland Cement Tile Grout.

Mortar: Mapei T / Keralastic, Mapei Granirapid (for fast setting), or Laticrete Multimax Lite. Dyna Flex 600 Polymer Modified Thin Set Mortar

Resin / Resin Hybrid Sand: ROMEX Ecofine Resin Jointing Sand, Alliance Gator Nitro Joint Sand, Techniseal NextGel Porcelain Paver Jointing Sand

Polymeric Sand: Dyna Optimax Polysand (for non-drainage bed) or Dyna Optimatrix (permeable bedding), Alliance Nitro Sand, Techniseal NOCO Polymeric Sand, Romex Rompox EcoFine

NOTE: It is strongly recommended that you consult with the manufacturers of these products to best understand which one is the most suitable based on your desired application and installation method. The information above is only indicative and Porcea Stone does not take responsibility for endorsement of any of the above products or warranty against any of the products.



BASE PREP. USING ROMEX

1. Compacted sub-grade.

2. Clear aggregate (3/4"):

- 6" depth for pedestrian
- 12" depth for vehicular

3. Romex Trass-Bed bedding layer:

- 1.5" depth for pedestrian
- 2" depth for 3 ton rating.
- 2.5" depth for 10 ton rating.
- 3" depth for 42 ton rating.

Pedestrian Loading

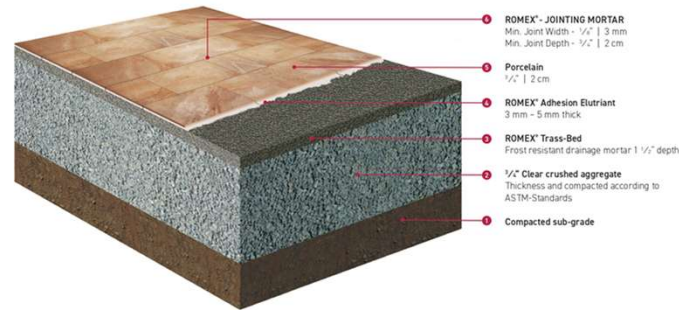

Vehicle Loading

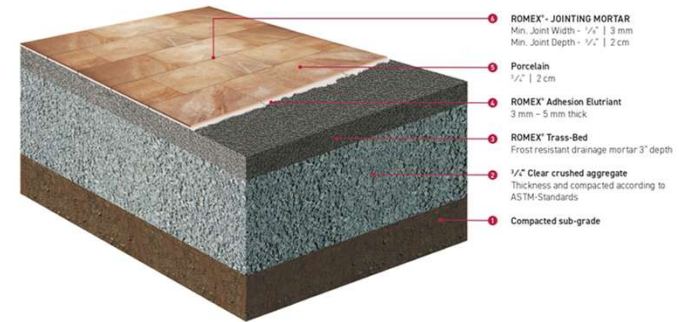

4. Romex Rompox Adhesion Elutriant 3-5 mm applied on back of the tile.

- Acts as thin set. Applied with a 1/4" notch trowel, and laid wet to wet with the Trass-bed layer.

5. Porcea Stone - 2 cm or 3 cm on top

6. Romex Jointing Sand- EcoFine - permeable silica sand.

Additional Information

- You can add filter cloths, geogrids, and make the base layers deeper depending the region, engineer requests, municipal requests, etc.
- Romex does have other build up recommendations for radiant heating, rooftops, bonded edge and on slab

NOTE: It is strongly recommended that you consult with the manufacturers of these products to best understand which one is the most suitable based on your desired application and installation method. The information above is only indicative.



SUGGESTIONS FOR DRIVEWAY INSTALLATION



- ✓ Concrete base is the most long-lasting method to install Porcea Stone for vehicular application
- ✓ Ensure the base is done properly with 2% slope to allow for water runoff and drainage
- ✓ Spread the adhesive on 100% of the back surface of the Porcea Stone tiles (3-4 mm is suggested, avoid empty areas)
- ✓ Use a rubber mallet to level the slabs once laid, fill the joints with grout
- ✓ Thermal expansion MUST be managed, every 5 to 6 linear meters install an expansion joint. Expansion joint MUST be all the way through the tile + adhesive + leveling screed thickness.
- ✓ You may consider: [Laticrete Guidelines](#)
- ✓ Porcelain tile adhesive is a better option in comparison to a mortar
- ✓ Install using a herringbone-pattern for added strength
- ✓ For snow plows, ensure a rubber attachment is used at the bottom of the front of the plow blade. Any metal blade can result in chipping and breakage.

NOTE: It is strongly recommended that you consult with the manufacturers of these products to best understand which one is the most suitable based on your desired application and installation method. The information above is only indicative.



SUGGESTIONS FOR CUTTING PORCEA STONE



- ✓ Use a continuous porcelain blade for cutting, wet cut with a table saw is the best option. Reinforced hub is preferred, there should be no notches or grooves (non-segmented blade)
- ✓ There's a blade called "The Beast" - price is usually around \$300
 - Different levels/types of this blade, get the one that has a 5 rating or higher (there will be little diamonds on it to show the rating)
 - Higher rating = smoother/symmetrical cut, you can get this blade at Prosol and other shops too
- ✓ Rigid Diamond Edge 10" reinforced hub Tile Blade, also found at Home Depot / Lowes
- ✓ Bridge Saws: Raimondi Pikus, SMS, or Raimondi Zoe wet saw
- ✓ Great North Hardscape offers a set of Rubi tools & blades designed specifically for use with Porcea Stone
 - <https://greatnorthhardscape.com/product-showcase/rubi-tools>
 - Various methods include score & snap, hand saws and bridge saws (most refined cut)
 - Contact: Pat Lackenbauer pat@gnhardscape.com for more information



NOTE: It is strongly recommended that you consult with the manufacturers of these products to best understand which one is the most suitable based on your desired application and installation method. The information above is only indicative.

THINGS TO KEEP IN MIND

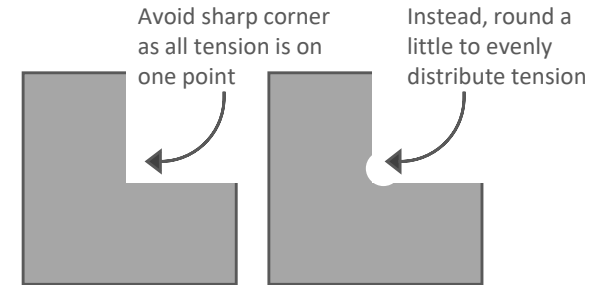

- ✓ Porcea Spacer required when dry-laying to ensure even joints & prevent chipping
- ✓ Use polymeric sands, mortars, and grouts specifically designed for outdoor porcelain tiles
 - ✓ Grout/joints: Mapei Ultra Colour Plus Max, Mapei Ultra Colour Plus FA Laticrete Permacolor
 - ✓ Mortar: Mapei T / Keralastic, Mapei Granirapid (for fast setting), or Laticrete Multimax Lite
- ✓ Ensure there is a 2% slope to allow for water run-off/drainage
- ✓ Spread the adhesive 100% over the back surface of the Porcea tile, 3-4mm suggested
- ✓ L-Copings should be used as cladding to concrete steps and installed with complete adhesion on the horizontal (tread) and the vertical (riser) pieces without overhang
- ✓ Take a look at some suggested installation options:
 - ✓ <https://www.alliancegator.com/gator-tile-system/>
 - ✓ https://techniseal.com/pro_en_ca/ez-base-foam-panels-70971147



NOTE: It is strongly recommended that you consult with the manufacturers of these products to best understand which one is the most suitable based on your desired application and installation method. The information above is only indicative.

THINGS TO KEEP IN MIND

- ✓ Planarity can be managed by the use of self-leveling spacer system such as:
 - <https://www.raimondispa.com/en/products/rls/rls-levelling-spacers-screw-system/>
 - Installing as per 1/3 or 1/4 free length, instead of 1/2



1/4 free length - OK



1/3 free length - OK



1/2 free length – avoid

NOTE: It is strongly recommended that you consult with the manufacturers of these products to best understand which one is the most suitable based on your desired application and installation method. The information above is only indicative.



Authorized Distributor



Email us at info@porceastone.com if you have questions or need additional information.

Please note the information in this catalogue is purely indicative. As case by case conditions will vary at the time of installation, Porcea Stone is not responsible for any damage or injuries as a result of improper installation of its products.