

issues

INFORMATION BULLETIN NO. RTC-081b

**TECHNICAL CONTENT OF THIS DOCUMENT IS APPROVED ON
THE BASIS OF AUTHORIZATION DOA NO. EASA.21J.057.**

1. **CONCERNING TO:** *SportStar RTC.*
2. **REASON:** *Operator's requirement.*
3. **REQUIRED ACTIONS:** *Installation of the MATCO brake system S3243001S.
(Replacement of the brake system RTC-S5 00-51 01 or
S3245001S).*
4. **LATEST DAY OF THE ACTION:** *According to the operator's decision.*
5. **CARIED OUT BY:** *Operator.*
6. **COST COVERED BY:** *Operator.*
7. **NECESSARY MATERIAL:** *The manufacturer according to the order.*
8. **WORK PROCEDURE:** *In accordance with the text of the bulletin.*
9. **APPENDICES:** *None.*

Valid from: 01. 04. 2026

**1. List of required tools and materials**

List of required tools are provided in the individual chapters of the SportStar RTC Maintenance manual, as referenced in the following text.

A breaker knife can be used to dismantle hoses at the glued point in the fuselage.

List of required materials:

Name	Drawing number / Nomenclature	Number of pieces / Dimension
Lever	S5 45-01 21	1 PC
Housing	S5 40-02 21	1 PC
Axis	S1 74-03 21	1 PC
Handle	S1 74-07 21	1 PC
Parking brake console	S5 45-02 21	1 PC
Long fork	S3243011D	2 PCS
Short fork	S3243012D	2 PCS
Double-side brake pedal L	E4 40-18 01	2 PCS
Double side brake pedal P	E4 40-18 02	2 PCS
Brake fluid reservoir	089964	1 PC
Master brake cylinder	089962	4 PCS
Direct connection	089967	1 PC
L-Shaped connection	089968	5 PCS
Brass 90° pressure elbow	089965	12 PCS
AEROTEC PA Hose	056546	1,00 m
Nylon hose	089971	12,00 m
Nylon hose	089972	1,00 m
Screw M4x12	004985	9 PCS
Screw M5x12	001670	2 PCS
Nut M16x1	031920	1 PC
Nut M4	033850	3 PCS
Nut M4	033601	1 PC
Washer 4,3	038204	7 PCS
Washer 17	036345	1 PC
Screw M8x4	004984	1 PC
Clip 1x4	059801	6 PCS
Clip 1x6	059602	1 PC
Pin 6x20	029331	4 PCS
Pin 5x20	028699	4 PCS
Cotter pin 1,6x12	040002	8 PCS
Grommet 6x1	076810	2 PCS
Cable tie	060332	25 PCS
Cable tie	060371	4 PCS
Protective spiral	079875	1,00 m
Self-adhesive clip	060461	16 PCS
TR KR 8x1	083960	0,40 kg
Rubber U-Profile	086866	0,15 m
Hydraulic fluid	097399	0,30 l
Connector	S5 00-67 21	1 PC
Parking brake valve	089973	1 PC
Washer 5,3	038193	9 PCS
Screw M5x35	011009	2 PCS
Washer 5,3	038180	6 PCS
Nut M5	033855	3 PCS
Screw M4x10	011886	2 PCS
Screw M6x16	011004	1 PC
Screw M5x14	016020	1 PC
Washer 4,3	038213	2 PCS

QS-406/F-08K

phone: +420 572 777 111 / +420 572 777 605

e-mail: service@evektor.com / evektor@evektor.com

<http://www.evektor.com>

Page: 2/15



List of required materials (continued):

Washer 6,5	038694	1 PC
Adhesive LOCTITE 577	096249	As required / min package
Sealant SABATACK 750 black	096227	As required / min package
Adhesive LOCTITE 648	096215	As required / min package
Sealant EMFIMASTIC PU 50 white	096257	As required / min package
Rivet 3,2x9,5	047950	2 PCS
Rivets for sealing holes after rivets and bolts on the firewall		
Rivet 3,2x6,4	047554	3 PCS
Rivet 4x9,5	047559	1PC
Cotter pins for brake pedal axles		
Cotter pin 2x20	039910	8 PCS
Wheels, brakes and wheel fairings		
Wheel with brake 6" left	089958	1 PC
Wheel with brake 6" right	089959	1 PC
Cheng Shin inner tube	764013	2 PCS
Cheng shin tyre	764012	2 PCS
Aerodynamic wheel fairings	S5 30-10 01	1 PC
Reduction	S5 00-32 21	8 PCS
Insert	S5 00-37 21	2 PCS
Screw M6x60	011839	8 PCS
Wheel axle	089961	2 PCS
Nut M6	035390	8 PCS
Washer 6,5	038694	8 PCS

2. Disassembly

This paragraph describes the disassembly procedures required to replace the existing brake system with the MATCO brake system.

References in the text refer to the SportStar RTC Maintenance manual, unless otherwise stated.

Before starting the disassembly of the brake system, drain the hydraulic fluid from the brake circuit (Chapter 12, Subchapter 12-10).

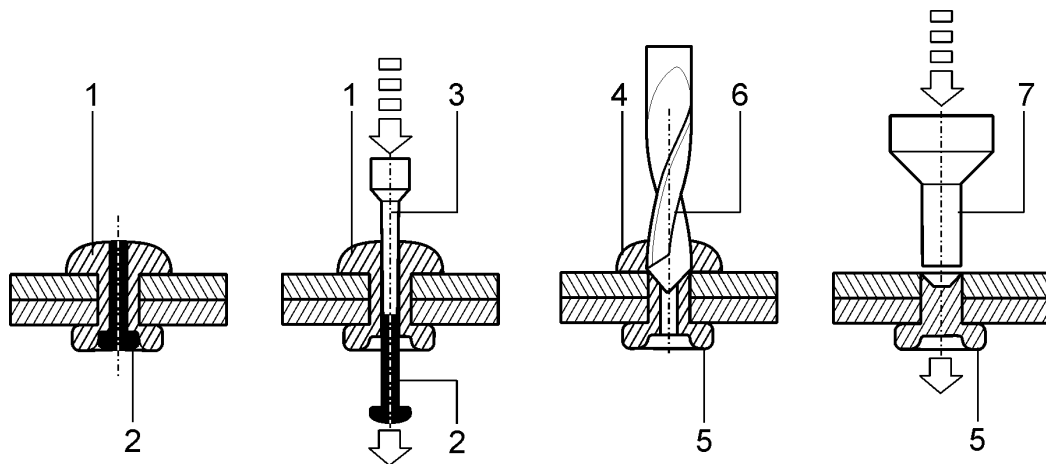

Pos.	Name	Pos.	Name
1	Rivet	5	Rivet blind head
2	Rivet mandrel	6	Drill bit
3	Mandrel ejector	7	Rivet shank ejector
4	Rivet head		

Fig.1 Rivet head drilling procedure



- 2.1 **Removal of the engine covers**
Remove the engine covers according to the procedure described in Chapter 71, subchapter 71-10.
- 2.2 **Removal of the upper fuselage cover**
Remove the upper fuselage according to the procedure described in Chapter 53, subchapter 53-30, paragraph 2, item B.
- 2.3 **Removal of the wing-to-fuselage fairings**
Remove the wing-to-fuselage fairings according to the procedure described in Chapter 53, subchapter 53-50, paragraph 2, item A.
- 2.4 **Removal of the interior equipment**
Remove the upholstery of the pilot seats in accordance with the procedure in chapter 25, subchapter 25-10, item A (Fig. 25-4, position 1).
Remove the equipment in the cockpit (side panels, carpets) according to the procedure described in Chapter 25, Fig.25-2, position 1; 2; 10 or Fig 25-3 position 1; 2; 9, depending on the type of interior.
Remove the flight control rod covers in accordance with the procedure in Chapter 25, subchapter 25-10, paragraph 2, item C.
As required, you may remove other interior equipment according to the procedures described in Chapter 25.
- 2.5 **Lifting of the airplane**
Lift the airplane according to the procedure described in Chapter 7.
- 2.6 **Removal of the landing gear fairings**
Remove the fairings of the main landing gear.
Remove the fairings of the landing gear according to the procedure described in Chapter 32, subchapter 32-10, paragraph 3, item B.
- 2.7 **Removal of wheels and brakes**
Remove the wheels, brakes and axis of the main landing gear.
Remove the wheels according to the procedure described in Chapter 32, subchapter 32-41, paragraph 2, item A.
Before any further handling of the wheels (removal), deflate the tire.
Remove the wheel axis according to Fig. 32-9, Chapter 32, subchapter 32-41 (position 2; 3; 16; 19; 4; 5). Use the washer (5, Fig- 32-9) during the installation of the new axis.
Remove the main wheel braked according to the Chapter 32, subchapter 32-42, paragraph 2, item A or B, depending on the type of brake installed.
- 2.8 **Removal of the hydraulic fluid reservoir**
Remove the hydraulic fluid reservoir from the firewall.
Proceed according to Fig. 2 in this bulletin.
Release the COBRA clips (6).
Remove the screw (9), nut (10) and washer (11) securing the clip (8).
Remove the hose (7)
Remove the screw (3), nut (4) and washer (5) securing the hydraulic fluid reservoir (1).
Remove the reservoir from the engine compartment.
Drill out the rivets securing the console (2).
The rivet head drilling procedure is shown in Fig. 1 in this bulletin.
Remove the elbow (12).
Remove the nut (13) with the washer (14).
Remove the union nut (16) and take off the hose.
Remove the connector (15).
- 2.9 **Removal of the brake pedals**
Remove the brake pedals according to the procedure described in Chapter 27, subchapter 27-20, paragraph 2, item A (3).
- 2.10 **Removal of the brake pumps**
Remove the brake pumps (E5 10-20 01 a E5 10-40 01 / 02) according to the procedures described in Chapter 32. Subchapter 32-42, paragraph 2, item C.
- 2.11 **Removal of the parking brake valve**
Remove the parking brake valve GOLDFREN or TOST according to the procedure described in Chapter 32, subchapter 32-42, paragraph 2, item H, (1) removal of the parking brake valve GOLDFREN or (3) parking brake valve TOST.



2.12 Removal of the parking brake valve console

Remove the parking brake valve console according to the procedure describes in Chapter 32, subchapter 32-50 (GOLDFREN), or Fig- 32-25 (TOST).

2.13 Removal of the parking brake indicator microswitch (if installed)

Remove the parking brake indicator microswitch according to the procedure described in Chapter 32, subchapter 32-50, paragraph 2, item I (1, GOLDFREN) or (3, TOST).

2.14 Removal of brake system hoses

According to Fig.3 in this bulletin, remove the screws (3), and take out the washer (2) and clip (1).

In the areas where the hoses are glued to the fuselage, cut the layer of the adhesive (EMFIMASTIC PU 50) with a sharp knife.

Pull the hose out of the fuselage.

Carefully remove any remaining adhesive so that the fuselage cover is not damaged.

Perform this activity with an assistant who will support the skin from the outside of the fuselage with a suitable mad.

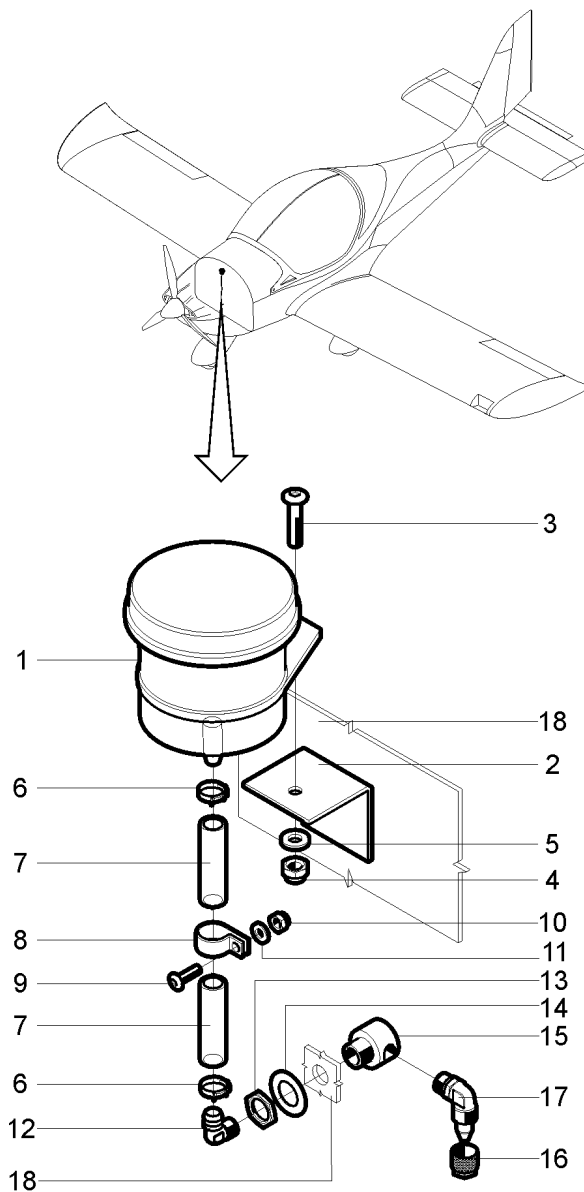
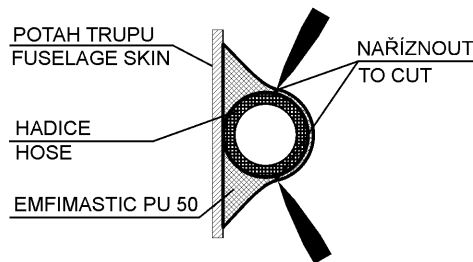
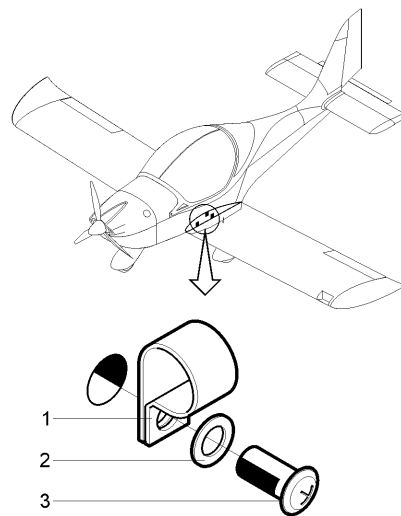

Fig.2, page 1 Removal of the hydraulic fluid reservoir



Pos.	Name	Pos.	Name
1	Hydraulic fluid reservoir	10	Nut
2	Console	11	Washer
3	Screw	12	Elbow
4	Nut	13	Nut
5	Washer	14	Washer
6	COBRA clip	15	Connector
7	Nut	16	Union nut
8	Clip	17	Elbow
9	Screw	18	Firewall (inf.)

Fig.2, page 2 Removal of the hydraulic fluid reservoir



Pos.	Name	Pos.	Name
1	Clip	3	Screw
2	Washer		

Fig. 3 Removal of hoses from the fuselage

3. Installation of the MATCO brake system

3.1 Pump assembly

According to Fig. 7a, view V in this bulletin, install the angle joints (089968) and brass elbows 90°-pressure (089965) onto the MATCO MCMC-4EV brake pump. (pos. 1; 2; 3; 4).

Degrease the elbows and joints with acetone. Apply LOCTITE 577 adhesive to the beginning and centre of the thread and install them onto the pumps. The angles of the elbows and joints are shown in Fig. 7a. view V. Do not spread the adhesive and assemble the parts within 4 minutes at the latest. Keep it cure for 8 hours. The installation of the elbows and joints determines the position of the pumps on the foot control pedal, which must be followed further.



Install the forks S 3243011D and S 3243012D onto the threaded ends of the pump pistons (position 1; 2; 3; 4), set the length L1 and L2 and tighten the nuts on the pump pistons against the forks.
Install the brake pumps onto the foot control pedal.

Pump MATCO pos.:	Fork, drawing number:	Pump setting length L1; L2, mm/in:	Brake pump control rod, drawing number
1	S 3243011D	160,5 mm / 6.31in	E4 40-18 01
2	S 3243012D	157,5 mm / 6.2 in	E4 40-18 01
3	S 3243011D	160,5 mm / 6.31 in	E4 40-18 02
4	S 3243012D	157,5 mm / 6.2 in	E4 40-18 02

3.2 Installation of pumps in the aircraft

According to Fig. 4 in this bulletin, position the assembled pumps onto the foot control pedal. According to detail B. Fig. 4, insert the pins (7; 5x20, nom. 028699) into the appropriate holes in the draft and pump. Slide the washer (8; 5,3, nom. 038193) onto the pins and secure them with cotter pins (9; 1,6x12, nom. 040002).

3.3 Installation of brake pump pedals

Install the pedals E4 40-18 01 a E4 40-18 02 onto the foot control pedals according to Fig. 4.

Secure the pedal axis (11) with cotter pins (12; 2x20, nom. 039310).

Connect the pedal levers to the pump forks according to detail A, Fig. 4 in this bulletin.

Align the holes for the pins in the forks and the pedal levers.

Insert the pins (6; 6x20, nom.029331), into to the appropriate holes, slide the washers (8; 6,4, nom. 038206) onto the pins and secure them with cotter pins (9; 1,6x12, nom.040002).

3.4 Installation of the parking brake valve

According to Fig. 5, detail G, view H in this bulletin, mark and drill ϕ 4,2 holes on the console S5 45-02 21. Use the screw to secure the console to the seat cushion sheet using the original riveted nut.

Mark the hole in the console onto the seat cushion sheet and drill them together. Remove the console, clean the drilled holes and position and tighten the rivet nut M4, OST 1 33260 – 89 (nom. 033601) with an M4 screw. Drill the holes for the rivets, remove the nut and clean the drilled holes. Rivet the nut using rivets 3,2 x 9,5 (nom. 1604 0412).

Mark the ϕ 4,2 hole on the lower side of the console and drill. Clean the holes, position and mark them onto the floor panel and drill. Install the parking brake valve console according to Fig. 5 using M4x12 (nom. 004985) screw on the upper side.

On the lower side, use M4x8 screws (nom. 004984), M4 nuts (nom. 033850) and washer 4,3 (nom. 038213).

Position the MATCO parking brake valve onto the console and test the movement of the parking brake control lever. Modify the holes in the console (S5 45-02 21) and the control cover (S1 02-28 21) according to Fig. 5, detail E, F.

Remove the parking brake valve, remove the blinds from the fittings, and install the brass elbows 90°-pressure (089965). Degrease the threads with acetone and secure the joints with LOCTITE 577 adhesive using the same procedure as in Section 3.1. After the adhesive has cured, install the parking brake valve onto the console using M5x35 screws (nom. 011009), washers 5,4 (nom.038180) and nuts M5 DIN 980 V (nom. 033855). Follow the procedure in Chapter 32, subchapter 32-42, paragraph 2, item H during installation. The washers 5,4 are placed under the nut and under the screw head.

3.5 Installation of the hydraulic fluid reservoir

According to Fig. 7b in this bulletin, mark and drill ϕ 5,3 holes in the firewall for securing the brake fluid reservoir console.

Install the console onto the firewall using screws (2, Fig.6 in this bulletin), washers (3) and nuts (4).

Install the cap (5) onto the console using a screw (7) with washer (6).

Insert the seal (8) into the cap (5) and screw the reservoir (9) on.

Install the fitting (10) with washer (11) into the bottom of the reservoir. Install the direct connection (12) into the thread of the fitting .

Slide the clip (14) onto the hose (13) and install it onto the thread of the fitting (12).

Install 2 elbow fitting (19) onto the connector (18).

Position the connector (18) with the fittings (19) into the ϕ 16,5 hole in the firewall. Slide the washer (21) onto the external thread of the connector and install the nut (20). The connector position (rotation) is



shown in Fig. 3b. view P (45°).

Tighten the nut in this position. Install the fitting (22) into the internal thread of the connector (18, Fig.6 in this bulletin). Connect the hose (13) to the fitting (22). Install the clip (14) into the ϕ 4,3 hole in the firewall using a screw (15), washer (16) and nut (17). During installation, secure the crew joints of hydraulic fluid lines between the reservoir, the reduction fitting, the hose and the connector with fittings using LOCTITE 577 adhesive according to Section 3.1.

3.6 Installation of main landing gear brakes and wheels

According to the chapter 32, subchapter 32-42, paragraph 2, item D, install the wheel fairing brackets, the main landing gear axles and the brake assemblies. During installation, use the washers (5, Fig. 32-9) from the original installation.

According to Chapter 32, subchapter 32-41, paragraph 2, item D, install the main landing gear wheels.

3.7 Installation of hoses

Insert the grommet into the hole in bulkhead no. 2 according to Fig. 7b, detail B (hose lines in the fuselage).

The placement of the clips is evident from details C and D as well as the gluing of the hose with SABA SEAL TACK 750 adhesive.

Before gluing with SABA SEAL TACK 750 adhesive, degrease the bonding surfaces with acetone and apply the adhesive after 8 minutes. The curing time is 24 hours.

The hose is supplied by the metre. Before installation, it is necessary to measure the required hose lengths according to Fig. 7a. 7b and 8.

The supply of hydraulic fluid from the reservoir on the firewall is performed using a nylon hose (nom. 089972). Behind the firewall to the pumps, the supply is routed via AEROTEC PA (nom. 056546).

The high-pressure part of the system consists of nylon hoses (nom. 089971).

The use of the VESTAMID protective tube (nom. 083960) and protective spirals (nom. 079875) is evident from Fig. 7a and 8a in this bulletin.

The hoses are connected to the fittings using union nuts which are included in the delivery of the fittings and elbows.

When installing the hoses to the foot control pedal using cable ties, proceed so that free control is maintained in all three possible pedal positions (Fig. 8).

Glue the U-profile (nom. 086866) onto the structure of bulkhead no.1 according to Fig. 8.

On the landing gear legs, the hoses are secured using cable ties 4,8x360 (nom. 060371) Fig. 7a. and 7b.

The cable ties are glued to the landing gear legs in the front area using EMFIMASTIC PU 50 white adhesive.

Degrease the area before gluing with alcohol and allow to ventilate for at least 8 minutes. Secure the cable ties with an appropriate amount of adhesive. Curing time is 24 hours.

During hoses installation, observe the minimum bend radius of the hoses according to Fig. 7b.

3.8 Installation of the microswitch

Install the parking brake indicator microswitch according to the procedure described in Chapter 32, Subchapter 32-50, item (2) and adjust it.

3.9 Plugging holes in the firewall

Plug the holes left by screws and rivets using rivets.

Rivet the holes remaining after the removal of the hydraulic fluid reservoir console using rivets 3,2x6,4.

Rivet the hole remaining after the screw that secured the hose clip using a rivet 4x9,5.

3.10 Brake system filling

Fill and bleed the brake system in accordance with the procedure described in Chapter 12.

3.11 Installation of interior equipment

Install all interior equipment parts removed in connection with the replacement of the brake system.

Carpets.

Side panels.

Flight control rod covers.

Pilot seat upholstery.

Other parts removed to facilitate the disassembly / installation of the brake system.

Perform installation according to the procedure described in Chapter 25.

3.12 Installation of wing-to-fuselage fairings

Install the wing-to-fuselage fairings according to the procedure described in Chapter 53, subchapter 53-50, paragraph 2, item A.

**3.13 Installation of the upper fuselage cover**

Install the upper fuselage cover located forward of the cabin according to the procedure described in Chapter 53 subchapter 53-30, paragraph 2, item B.

3.14 Installation of engine cover

Install the engine cover according to the procedure describe in Chapter 71, subchapter 71-10.

3.15 Aircraft lowering

Lower the aircraft from the supports according to the procedure described in Chapter 07.

3.16 Brake test

During taxiing test the functionality of the brake system several times.

Anticipate a possible reduced braking efficiency and adjust taxiing speed accordingly so that the aircraft can safely taxi to the stop before any potential obstacle or the end of the runway.

3.17 Installation of the aerodynamic fairings

Install the aerodynamic fairings (if used) according to the Chapter 32, subchapter 32-10, paragraph 3, item B.

3.18 Aircraft weighing

Perform a check weighing of the aircraft according to the Chapter 8 and determine the empty weight and center of gravity after installation of the MATCO braking system.

4. Operational documentation

4.1 Without affecting the accompanying technical documentation.

4.2 Record the work performed on the aircraft into the aircraft logbook.

Installation of the MATCO brake system performed according to Information bulletin RTC-081b, date and signature.

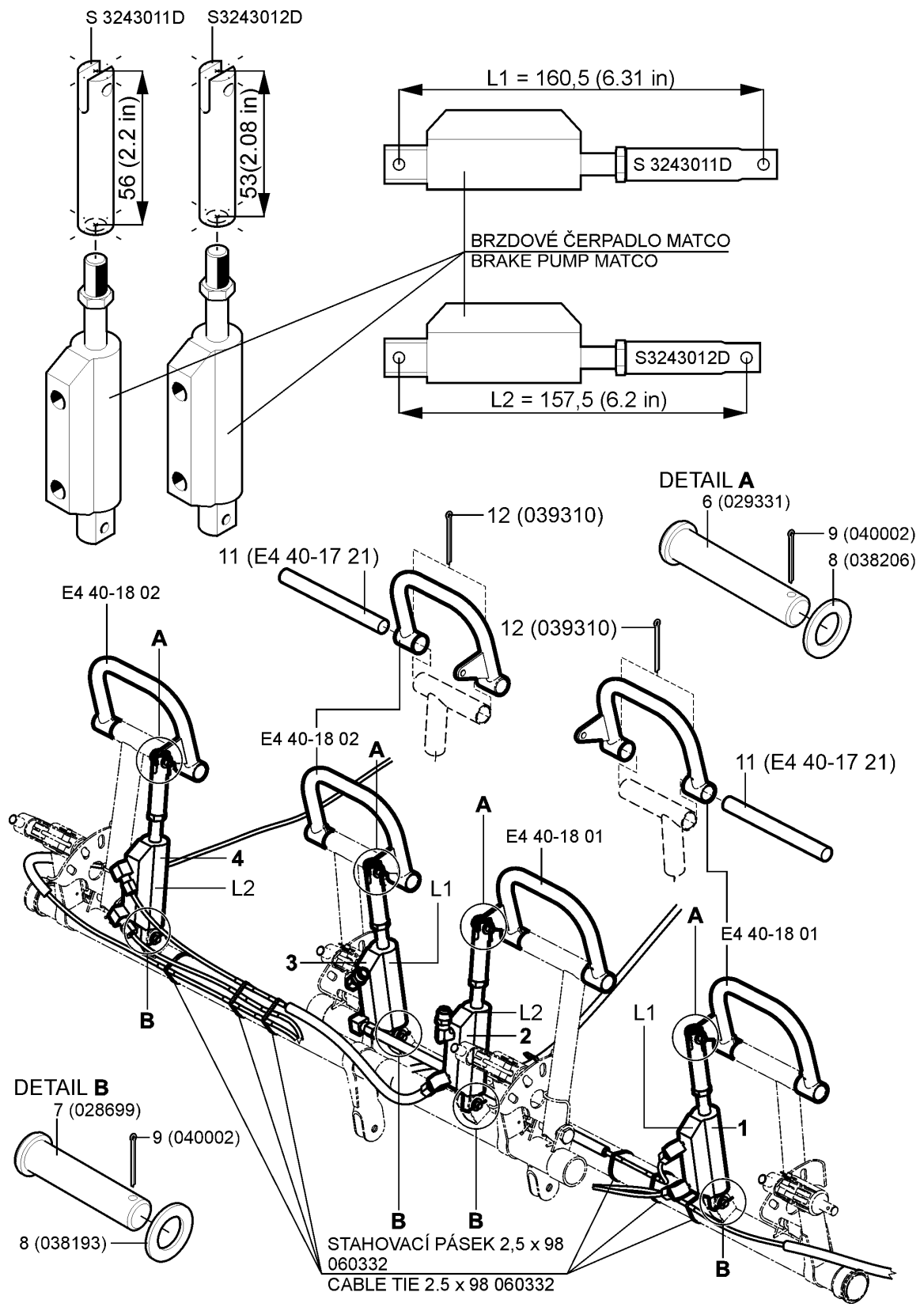

Fig. 4 Installation of brake pumps

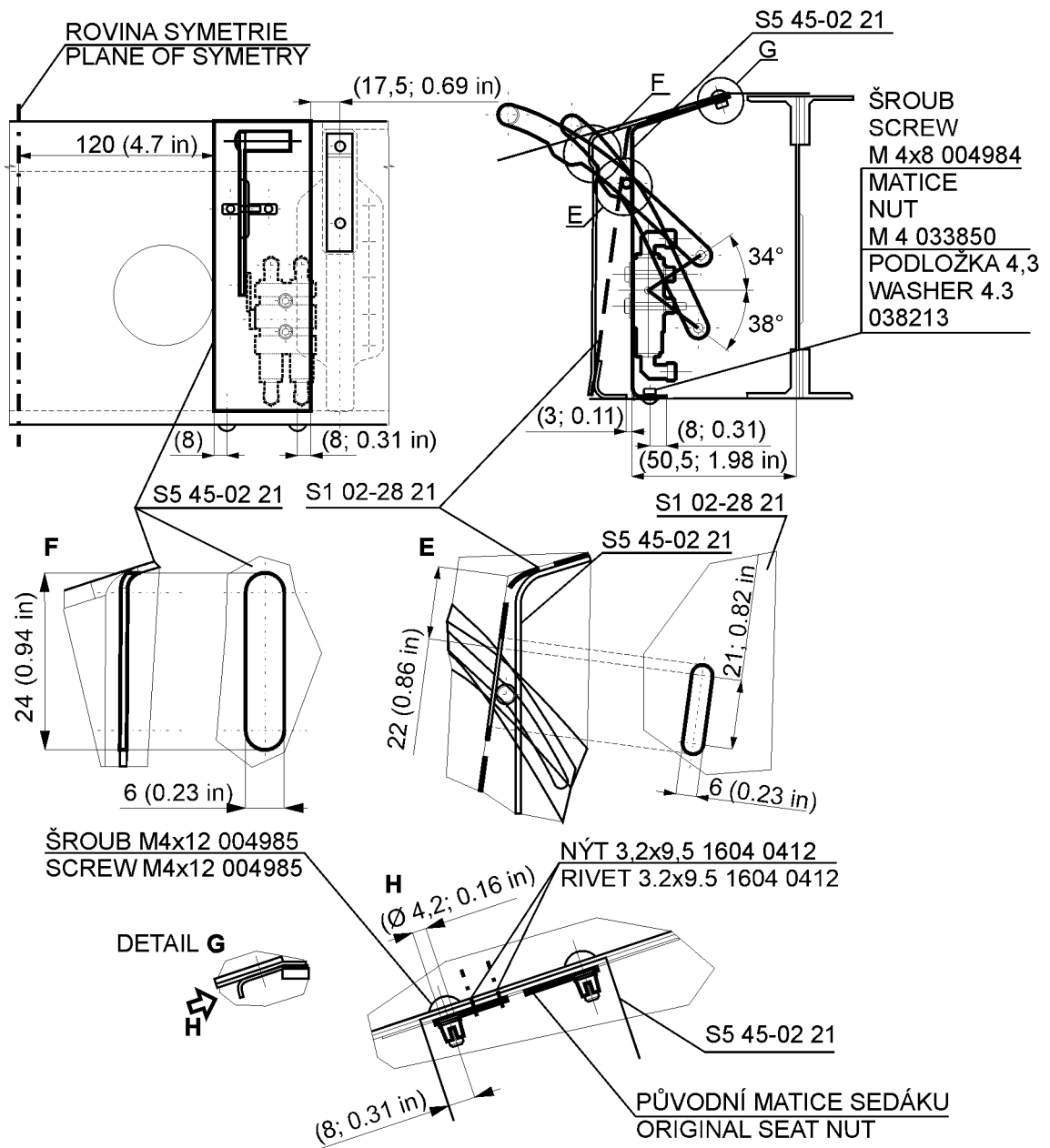
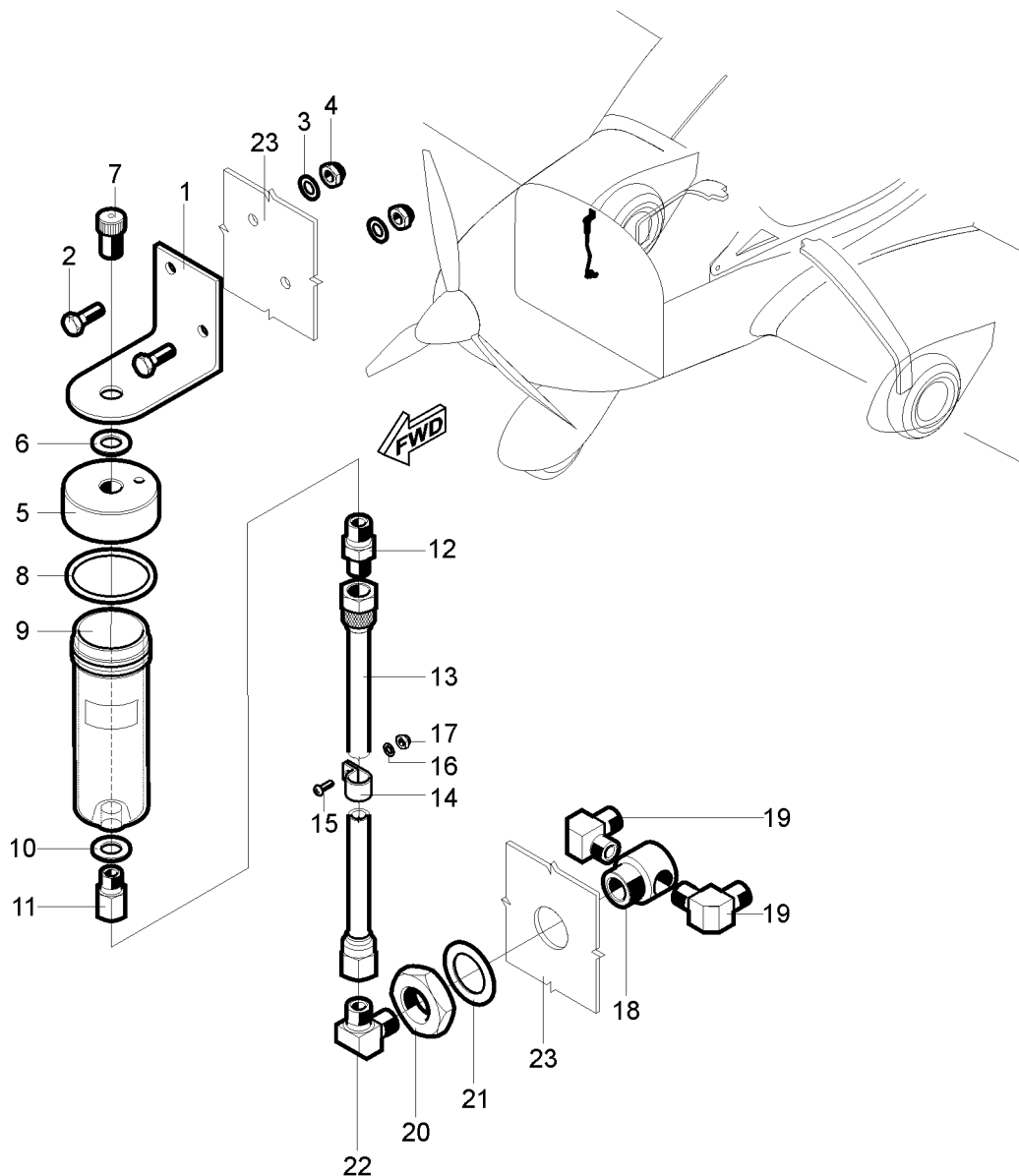
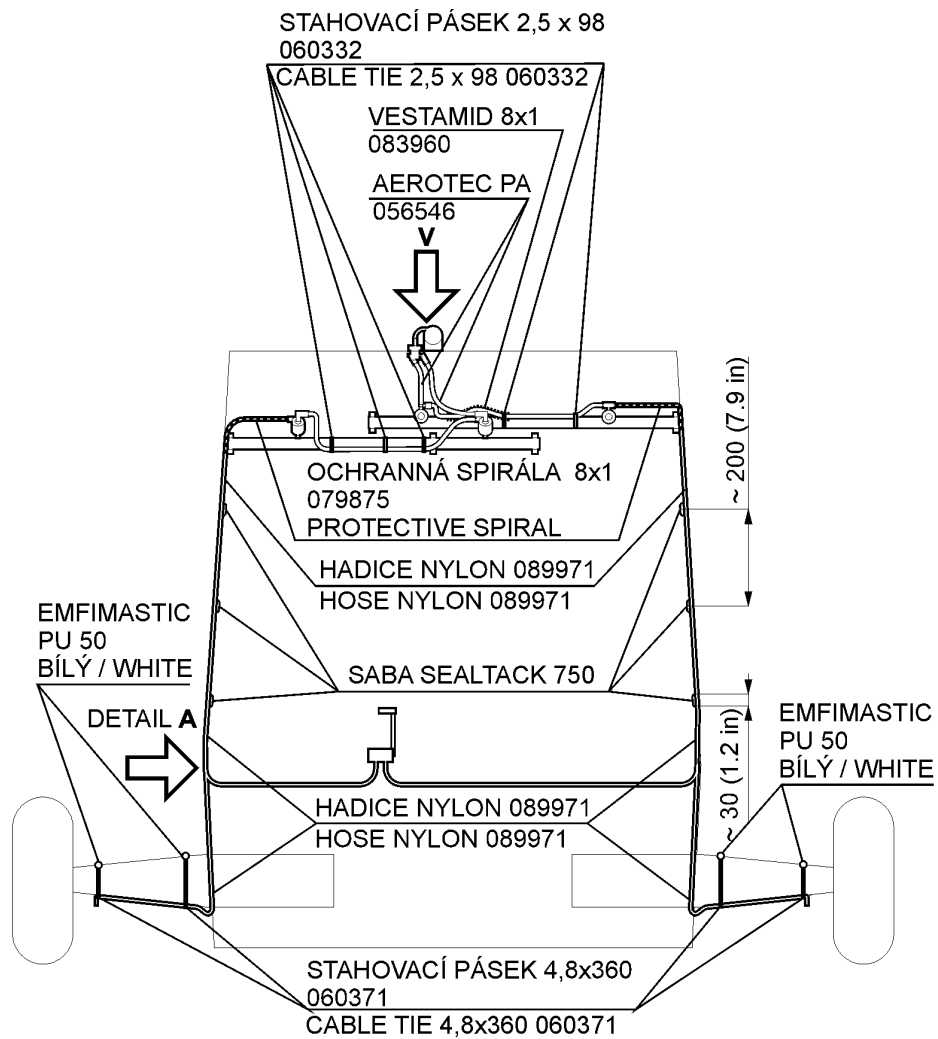

Fig. 5 Installation of parking brake valve



Pos.	Name	Pos.	Name
1	Console MATCO	12	Direct connection (089967)
2	Screw M5x12 (001670)	13	Nylon hose (089972)
3	Washer 5,3 (038180)	14	Clip 1x6 (059602)
4	Nut M5 (033855)	15	Screw M4x12 (004985)
5	Cap MATCO	16	Washer 4,3 (038180)
6	Washer MATCO	17	Nut M4 (033855)
7	Screw MATCO	18	Connector S5 00-67 21
8	O-ring MATCO	19	Angled connection – L (089968)
9	Reservoir MATCO	20	Nut M16x1 (031920)
10	Washer MATCO	21	Washer 17 (036345)
11	Reduction MATCO	22	Angled connection – L (089968)

Fig. 6 Installation of hydraulic fluid reservoir (MATCO)



PŘÍPOJKA ÚHLOVÁ - L, 089968
ANGLED CONNECTION - L, 089968
L1/8" NPT-1/4"

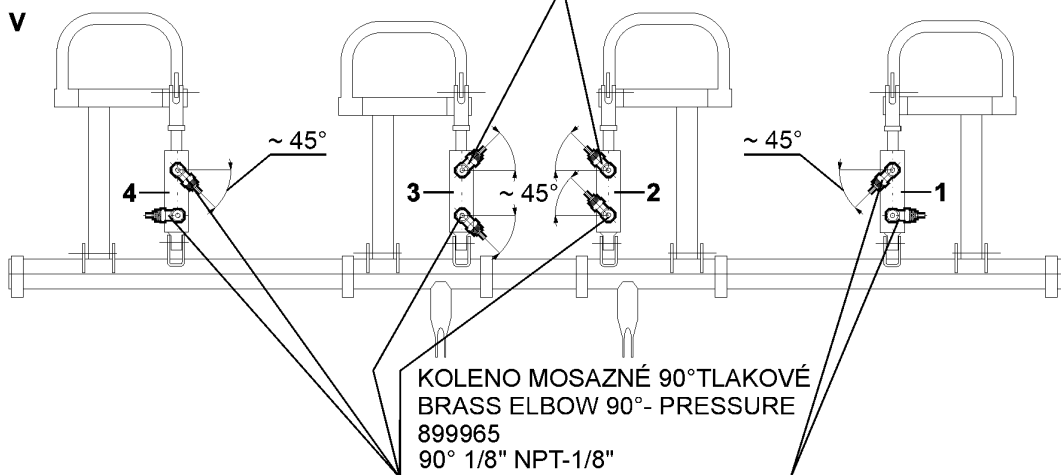

Fig. 7a Installation of hoses in the fuselage

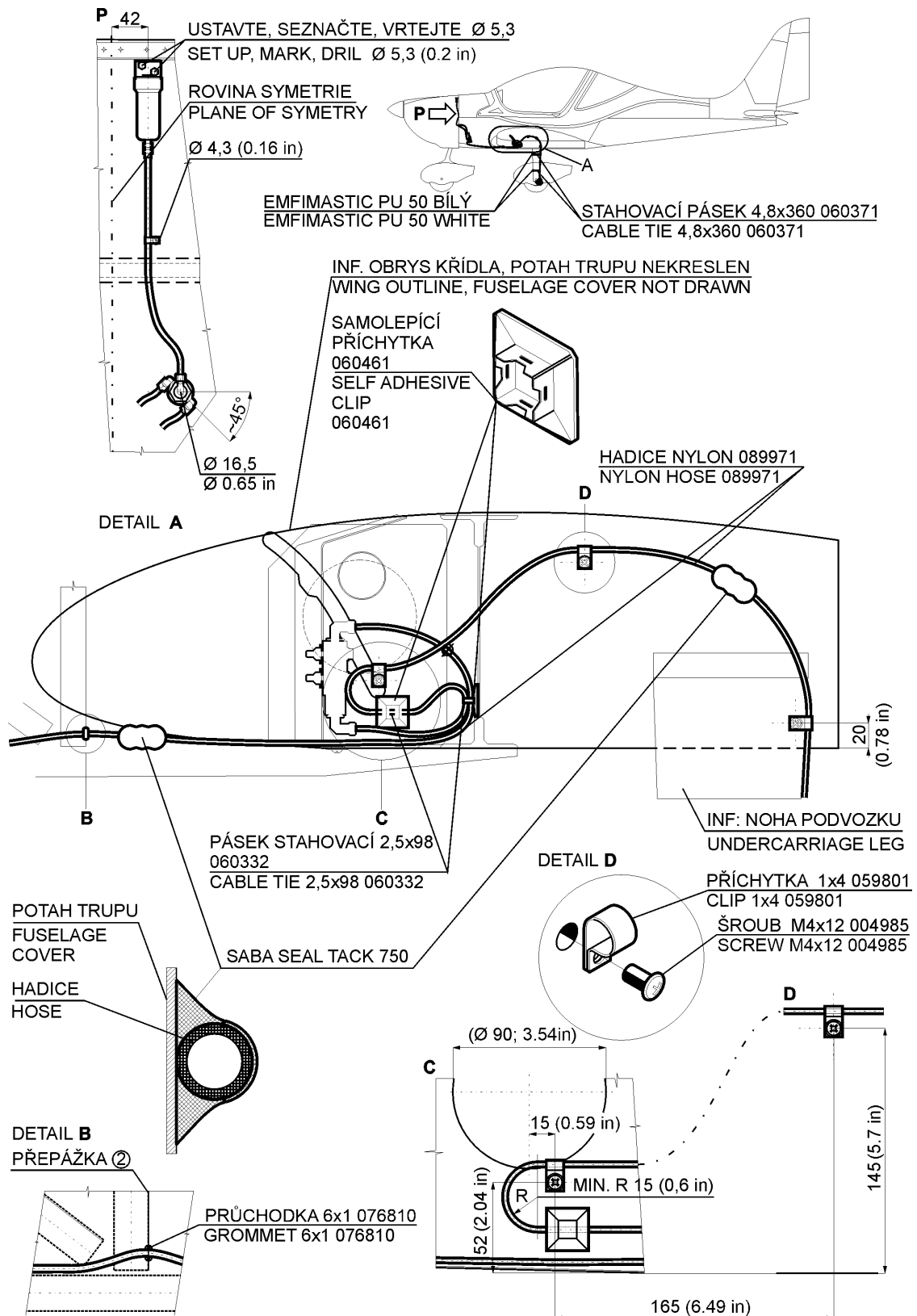

Fig. 7b Installation of hoses in the fuselage

