



## CLOAK 250 / Sconce

WALL LIGHT

Cloak is defined by its clean profile and considered detailing. Refined fixings are thoughtfully resolved, while textured glass lends depth and tactility to the form.

The design centres on the warmth and diffusion of light through hand-formed glass, creating a soft ambient glow. Each panel is individually moulded, giving every piece subtle variation.

Rooted in design and craftsmanship, Cloak is a beautifully resolved object as much as it is a source of light.

*Note: There are natural variations in the glass profile due to the gravity slumping process.*

MADE IN MELBOURNE, AUSTRALIA

### FINISHES

FRAME	<input checked="" type="radio"/> Bronze	<input checked="" type="radio"/> Black Ace	<input type="radio"/> White
GLASS	<input checked="" type="radio"/> Ribbed Grey	<input type="radio"/> Ribbed Clear	<input checked="" type="radio"/> Ribbed Bronze
	<input checked="" type="radio"/> Textured Grey	<input type="radio"/> Textured Clear	<input checked="" type="radio"/> Textured Bronze

### SPECIFICATIONS

LEAD-TIME Enquire at [info@southdrawn.com.au](mailto:info@southdrawn.com.au)

SHADE 250mm Tall Glass

FRAME Aluminium, Powder Coated

CONTROL Remote Driver, Dali or Phase

RATING IP65

LAMP LED Module, Constant Current

POWER/TEMP 3.6W, 2700k (Warm) (3000k available)

OUTPUT 500 lm

AVG LIFETIME 50,000 hours

INSTALLATION Sconce must be installed and wired by a qualified electrician.

WARRANTY 3 Years Manufactures Warranty

CARE

Ensure the electricity supply is switched off before cleaning. Remove dust with a soft dry cloth. Do not use solvents or abrasive materials when cleaning.

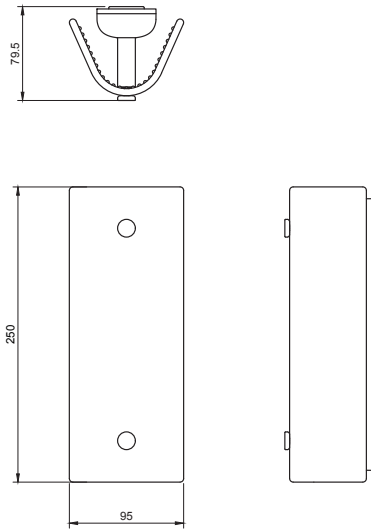

Dims: 95mm W x 250mm H x 79.5mm D  
Weight: 0.8kg