

PRODUCT CATALOGUE

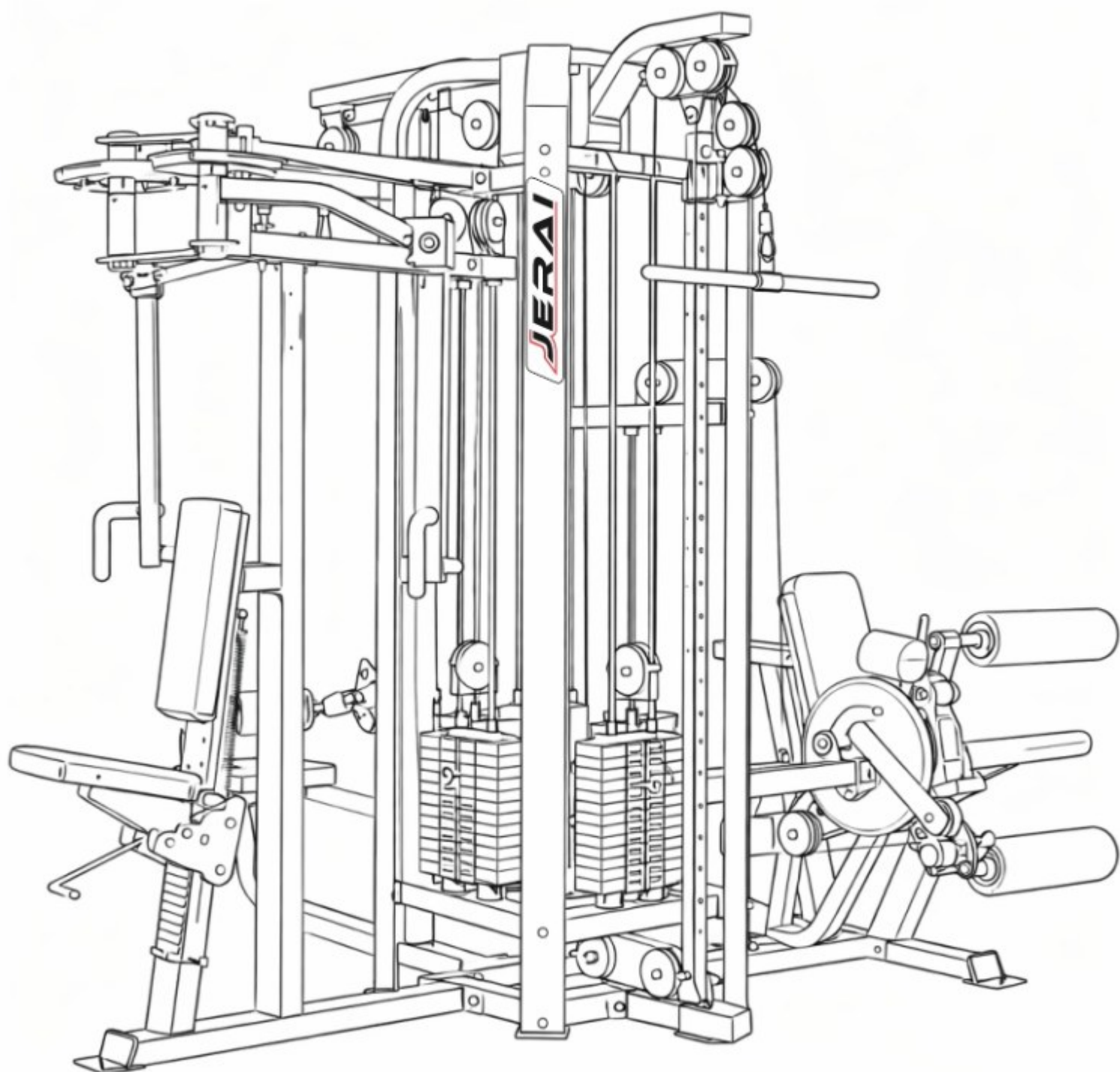

SINCE 1994



Jerai Fitness is an Indian manufacturer with over three decades of expertise in designing and producing world-class fitness equipment. The company caters to a diverse clientele, including commercial gyms, hotels, corporate wellness centers, and real estate projects, serving both the domestic market and 26 international markets such as USA, UK, Germany, Japan, Australia, Sweden, UAE, Saudi Arabia, and France, among others. With 9 official international distributors, Jerai Fitness ensures seamless access, service, and support worldwide - combining global reach with strong regional impact.

Through years of industry experience, Jerai Fitness has developed strong capabilities in manufacturing processes, inventory management, distribution efficiency, and customer service, enabling it to consistently deliver reliable and innovative fitness solutions. A pan-India network of 15 exclusive showrooms strengthens customer engagement, provides accessible support, and enhances brand reach.

As a pioneer in automated manufacturing, Jerai Fitness incorporates robotic welding, advanced assembly techniques, and high-precision Turkish and Japanese machinery into its production processes. This modern infrastructure ensures accuracy, durability, and compliance with international standards, while enabling the company to scale operations, meet increasing global demand, and remain competitively priced.

JX-FIT

SERIES



The JX-FIT Series is a versatile range of functional training equipment designed to elevate your workout experience. From multi-gyms and jungles to rigs, racks, and training cages, it covers all your fitness needs. Each piece is rigorously tested to deliver top-tier performance, reliability, and safety-perfect for high-intensity training environments.

EUROPEAN
STANDARDS
EN ISO 20957-1:2013,
EN957-2:2021



ASTM F2216-17A



MULTI GYM (UPPERBODY) J4MGU



- ▣ L : 152 inches / 386 cms
- ▣ W : 85 inches / 216 cms
- ▣ H : 92 inches / 234 cms



FEATURES:

- ▶ PEC FLY / REAR DELT
- ▶ LAT PULL DOWN
- ▶ LONG PULL ROW
- ▶ HIGH LOW PULLEY
- ▶ 4 SIDE WEIGHT STACKS (220 LBS / 100 KGS EACH)



MULTI GYM WITH SEATED LEG CURL / EXTENSION COMBO.

J4MGC



- ▣ L : 85 inches / 216 cms
- W : 115 inches / 292 cms
- H : 92 inches / 234 cms



FEATURES:

- ▶ PEC FLY / REAR DELT
- ▶ LAT PULL DOWN
- ▶ SEATED LEG CURL / EXT. COMBO
- ▶ HIGH LOW PULLEY
- ▶ 4 SIDE WEIGHT STACKS (220 LBS / 100 KGS EACH)



MULTI GYM (LOWERBODY)

J4MGL



- ▣ L : 115 inches / 292 cms
- W : 95 inches / 241 cms
- H : 80 inches / 203 cms



FEATURES:

- ▶ LEG EXTENSION
- ▶ SEATED LEG CURL
- ▶ SEATED LEG PRESS (400 LBS / 180 KGS)
- ▶ STANDING CALF
- ▶ 3 SIDE WEIGHT STACKS (220 LBS / 100 KGS EACH)



5 STATION MULTI GYM J5MG



- ❑ L : 218 inches / 554 cms
- W : 115 inches / 292 cms
- H : 92 inches / 234 cms



FEATURES:

- ▶ PEC FLY / REAR DELT
- ▶ LAT PULL DOWN
- ▶ LONG PULL ROW
- ▶ CABLE CROSSOVER
- ▶ 5 SIDE WEIGHT STACKS (220 LBS / 100 KGS EACH)



4 STATION MULTI GYM & 4 STATION JX - FIT J8XMG



- ☑ L : 192 inches / 488 cms
- W : 115 inches / 292 cms
- H : 92 inches / 234 cms



FEATURES:

- ▶ PEC FLY / REAR DELT
- ▶ LAT PULL DOWN
- ▶ LONG PULL ROW
- ▶ HIGH LOW PULLEY
- ▶ CABLE CROSSOVER
- ▶ BOXING BAG WITH CONNECTOR
- ▶ VERTICAL LADDER
- ▶ PULL-UP STATION
- ▶ HIGH LOW BATTLE ROPE STATION
- ▶ T-BAR PIVOT
- ▶ TRX ATTACHMENT
- ▶ VERSA SPACE
- ▶ DIP STATION
- ▶ STEP UP STATION
- ▶ ACCESSORIES RACK
- ▶ 5 SIDE WEIGHT STACKS (220 LBS / 100 KGS EACH)



JX - FIT MULTI JUNGLE JXMJ



- ☑ L : 324 inches / 823 cms
W : 120 inches / 305 cms
H : 92 inches / 234 cms

FEATURES:

- ▶ 4 HALF RACK
- ▶ VERTICAL LADDER
- ▶ HORIZONTAL MONKEY LADDER
- ▶ BAR HOLDER X 4 NOS.
- ▶ TRX STATION
- ▶ KETTLE BELL RACK
- ▶ ACCESSORIES RACK
- ▶ DIP STATION
- ▶ STEP-UP STATION
- ▶ T-BAR PIVOT
- ▶ HIGH LOW BATTLE ROPE STATION
- ▶ PULL UP STATION
- ▶ BOXING BAG



8 STATION MULTI GYM & 4 STATION JX - FIT J12XMG



- ☑ L : 264 inches / 671 cms
- W : 240 inches / 610 cms
- H : 92 inches / 234 cms



FEATURES:

- ▶ PEC FLY / REAR DELT
- ▶ LAT PULL DOWN
- ▶ LONG PULL ROW
- ▶ DUAL CABLE CROSSOVER
- ▶ ASSISTED DIP CHIN
- ▶ SEATED LEG CURL / EXTENSION COMBO.
- ▶ BOXING BAG
- ▶ PULL-UP STATION
- ▶ VERTICAL LADDER
- ▶ DIP STATION
- ▶ HIGH LOW BATTLE ROPE STATION
- ▶ T-BAR PIVOT
- ▶ TRX STATION
- ▶ STEP-UP STATION
- ▶ ACCESSORIES RACK
- ▶ 9 SIDE WEIGHT STACKS (220 LBS / 100 KGS EACH)



PERSONAL TRAINING STATION JPTS



- ▣ L : 100 inches / 254 cms
- ▣ W : 88 inches / 224 cms
- ▣ H : 90 inches / 229 cms



FEATURES:

- ▶ DUAL ADJUSTABLE PULLEY CABLE STATION
- ▶ INTEGRATED SMITH STATION
- ▶ MULTIPLE PULL-UP STATION
- ▶ FREE WORKOUT RACK
- ▶ HOOK MOUNT
- ▶ 3 SIDE WEIGHT STACKS (220 LBS / 100 KGS EACH)



Optional Attachment*



4 SIDE HIGH LOW PULLEY J4MP



☑ L : 58 inches / 147 cms
W : 58 inches / 147 cms
H : 92 inches / 234 cms



FEATURES:

- ▶ 4 SIDE SINGLE HIGH-LOW PULLEY STATION
- ▶ FOOT ROW BAR
- ▶ 4 SIDE WEIGHT STACKS (220 LBS / 100 KGS EACH)

*Attachments, Accessories, Weight Plates, Dumbbells & Bars to be Ordered Separately



FOREARM JUNGLE JFJ



- ❑ L : 60 inches / 152 cms
- W : 60 inches / 152 cms
- H : 48 inches / 122 cms



FEATURES:

- ▶ WRIST CURL
- ▶ GORILLA GRIPPER
- ▶ FOREARM TWIST
- ▶ FOREARM ROTATION



BATTLE ROPE JUNGLE JXBRJ



- ❑ Dia : 20 inches / 51 cms
- H : 14 inches / 36 cms

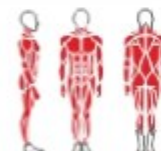

FEATURES:

- ▶ CENTRE ROD FOR WEIGHT PLATE LOADING
- ▶ THREE ROPE ANCHORS



SLEDGE JXS



- ☑ L : 30 inches / 76 cms
- W : 30 inches / 76 cms
- H : 20 inches / 51 cms

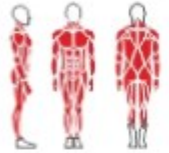

FEATURES:

- ▶ TWO SIDE RODS FOR WEIGHT PLATE LOADING
- ▶ MULTIPLE GRIP OPTIONS
- ▶ ROPE HOOK



STRETCH TRAINER JST



- ☑ L : 59 inches / 150 cms
- W : 31 inches / 79 cms
- H : 43 inches / 109 cms

FEATURES:

- ▶ DUAL PEDALS
- ▶ MOVING SEAT
- ▶ ADDITIONAL SUPPORT PAD
- ▶ DUAL FOOT SUPPORT ROLLERS
- ▶ MULTIPLE GRIP OPTIONS
- ▶ TRAINING INSTRUCTION BOARD



TYRE LIFT JTL



- Dia : 50 inches / 127 cms
- H : 40 inches / 102 cms

FEATURES:

- ▶ DUAL RODS FOR WEIGHT PLATE LOADING
- ▶ DUAL ROPE ANCHORS

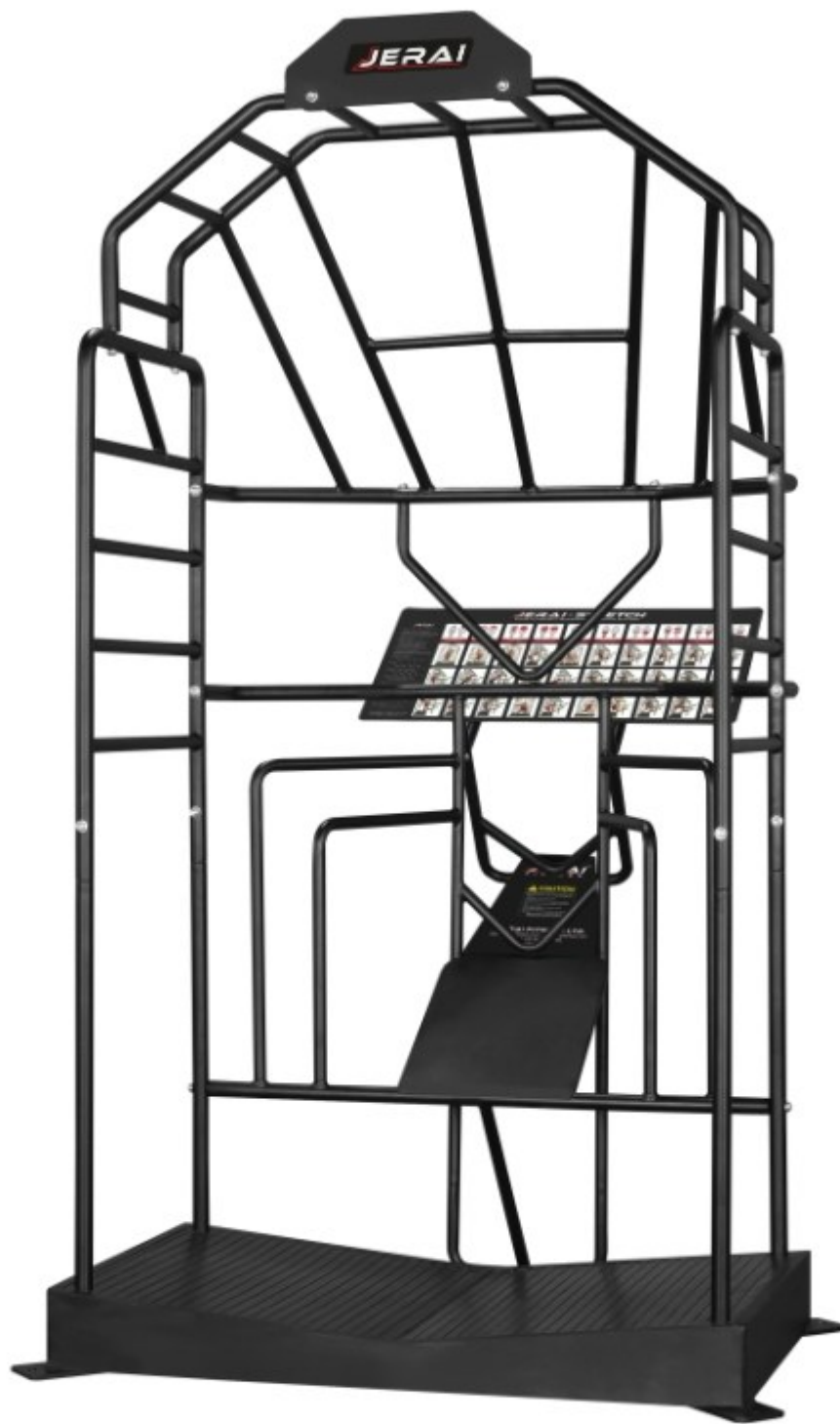

STRETCH CAGE JSC



▣ L : 60 inches / 153 cms
W : 48 inches / 122 cms
H : 87 inches / 221 cms

FEATURES:

- ▶ STURDY CAGE DESIGN WITH MULTI-LEVEL GRIPS
- ▶ INSTRUCTIONAL EXERCISE CHART INCLUDED
- ▶ STABLE BASE PLATFORM
- ▶ INCLINED PLATFORM FOR FOOT SUPPORT



VERTICAL JX - FIT JXV



☑ L : 95 inches / 241 cms
W : 91 inches / 231 cms
H : 122 inches / 311 cms

FEATURES:

- ▶ REBOUNDER STATION
- ▶ STEP-UP STATION
- ▶ DIP STATION
- ▶ PUNCHING BAG
- ▶ ROPE ANCHOR
- ▶ T-BAR STATION
- ▶ CROSS TRAINING WOODEN FITNESS RINGS
- ▶ PULL-UP BARS
- ▶ MINI ACCESSORIES RACK



SHAPE XX JXSXX



▣ L : 295 inches / 749 cms
W : 125 inches / 318 cms
H : 96 inches / 243 cms

FEATURES:

- ▶ DUAL ADJUSTABLE PULLEY
- ▶ HALF RACK
- ▶ BOXING BAG
- ▶ DIP STATION
- ▶ STEP-UP STATION
- ▶ T-BAR STATION
- ▶ REBOUNDER STATION
- ▶ HIGH LOW BATTLE ROPE STATION
- ▶ PULL-UPS STATION
- ▶ TRX STATION
- ▶ DUAL LADDER
- ▶ MONKEY BAR
- ▶ ACCESSORIES RACK
- ▶ WEIGHT PLATE HOLDERS
- ▶ DUAL WEIGHT STACKS (220 LBS / 100 KGS EACH)

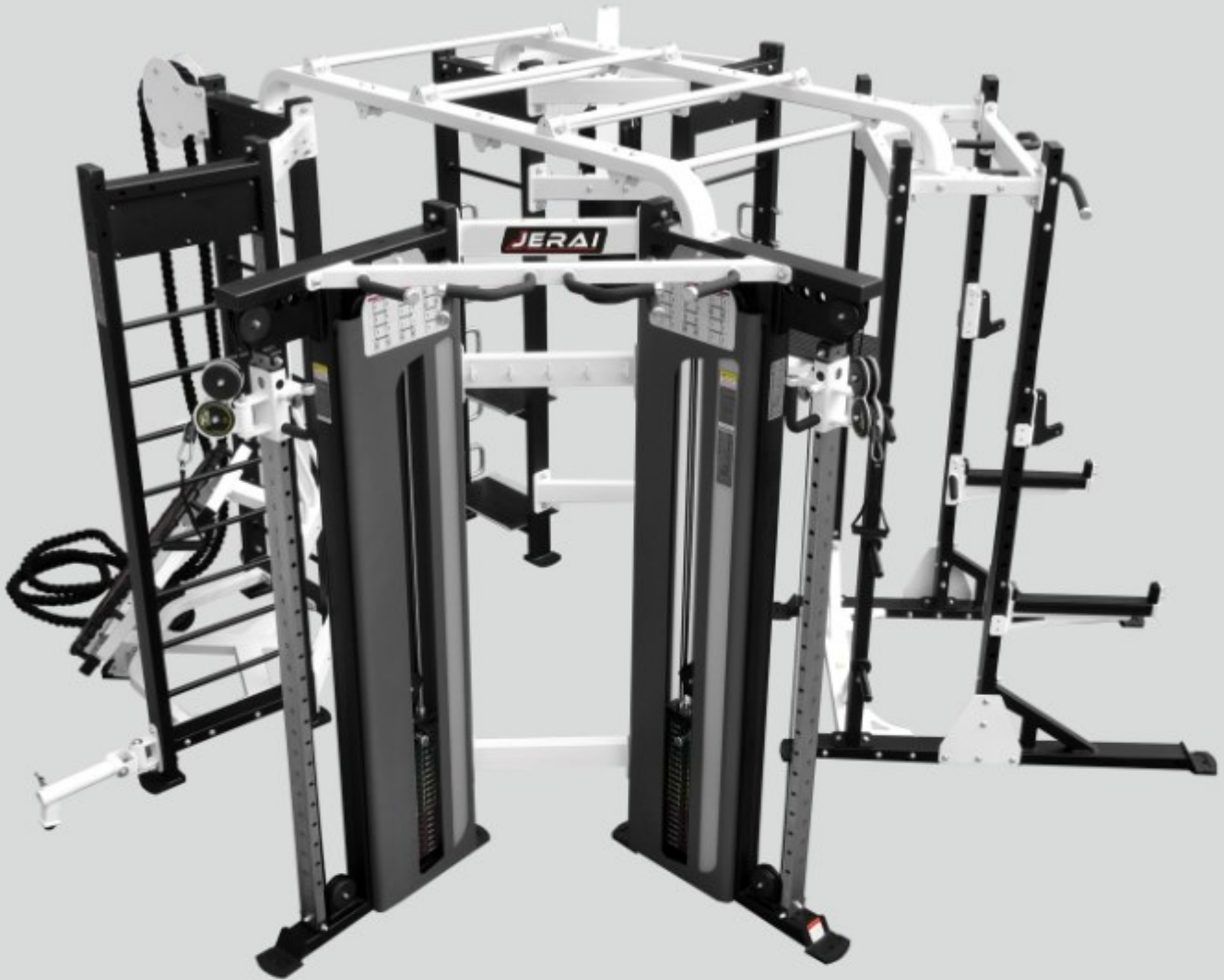

SHAPE O JXSO



- ☑ L : 141 inches / 358 cms
W : 137 inches / 348 cms
H : 96 inches / 243 cms

FEATURES:

- ▶ DUAL ADJUSTABLE PULLEY
- ▶ HALF RACK
- ▶ BOXING BAG
- ▶ DIP STATION
- ▶ STEP-UP STATION
- ▶ T-BAR STATION
- ▶ REBOUNDER STATION
- ▶ HIGH LOW BATTLE ROPE STATION
- ▶ PULL-UP STATION
- ▶ TRX STATION
- ▶ DUAL LADDER
- ▶ MONKEY BAR
- ▶ ACCESSORIES RACK
- ▶ WEIGHT PLATE HOLDERS
- ▶ BAR CATCHES CONNECTOR
- ▶ DUAL WEIGHT STACKS (220 LBS / 100 KGS EACH)



SHAPE T JXST



📏 L : 185 inches / 470 cms
W : 124 inches / 315 cms
H : 96 inches / 243 cms

FEATURES:

- ▶ HALF RACK
- ▶ BOXING BAG
- ▶ DIP STATION
- ▶ STEP-UP STATION
- ▶ REBOUNDER STATION
- ▶ PULL-UP STATION
- ▶ T-BAR STATION
- ▶ HIGH LOW BATTLE ROPE STATION
- ▶ TRX STATION
- ▶ DUAL LADDER
- ▶ MONKEY BAR
- ▶ ACCESSORIES RACK
- ▶ WEIGHT PLATE HOLDERS

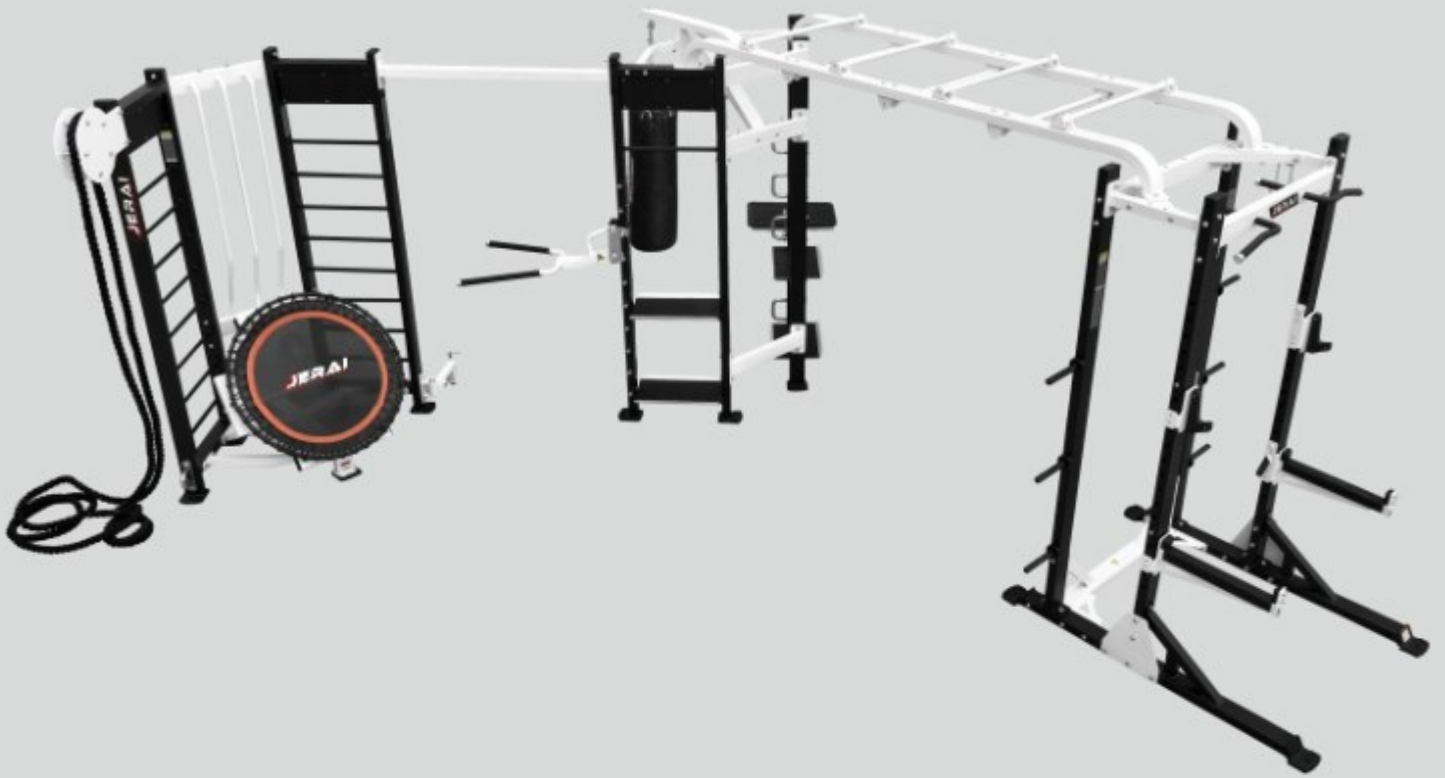

SHAPE L JXSL



▣ L : 189 inches / 480 cms
W : 128 inches / 325 cms
H : 96 inches / 243 cms

FEATURES:

- ▶ HALF RACK
- ▶ BOXING BAG
- ▶ DIP STATION
- ▶ STEP-UP STATION
- ▶ T-BAR STATION
- ▶ REBOUNDER STATION
- ▶ HIGH LOW BATTLE ROPE STATION
- ▶ PULL-UP STATION
- ▶ TRX STATION
- ▶ DUAL LADDER
- ▶ MONKEY BAR
- ▶ ACCESSORIES RACK
- ▶ WEIGHT PLATE HOLDERS



SHAPE I JXSI



📏 L : 189 inches / 480 cms
W : 65 inches / 165 cms
H : 96 inches / 243 cms

FEATURES:

- ▶ HALF RACK
- ▶ BOXING BAG
- ▶ DIP STATION
- ▶ STEP-UP STATION
- ▶ PULL-UP STATION
- ▶ ACCESSORIES RACK
- ▶ MONKEY BAR
- ▶ WEIGHT PLATE HOLDERS



SHAPE S JXSS



📏 L : 128 inches / 325 cms
W : 44 inches / 112 cms
H : 96 inches / 243 cms

FEATURES:

- ▶ BOXING BAG
- ▶ DIP STATION
- ▶ STEP-UP STATION
- ▶ T-BAR STATION
- ▶ REBOUNDER STATION
- ▶ HIGH LOW BATTLE ROPE STATION
- ▶ DUAL LADDERS
- ▶ ACCESSORIES RACK

ATTACHMENTS

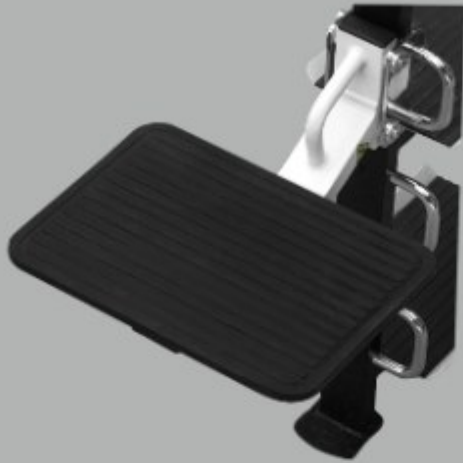

STEP BOARD



PUNCHING BAG

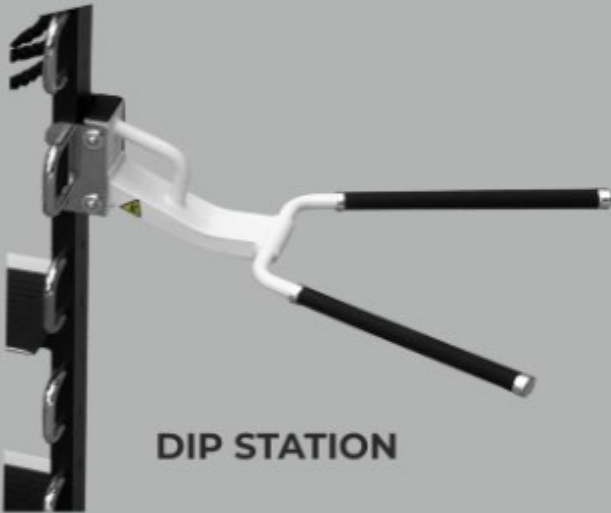

DIP STATION

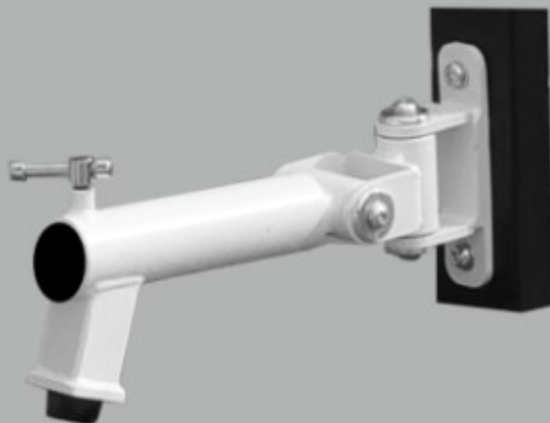

T-BAR STATION

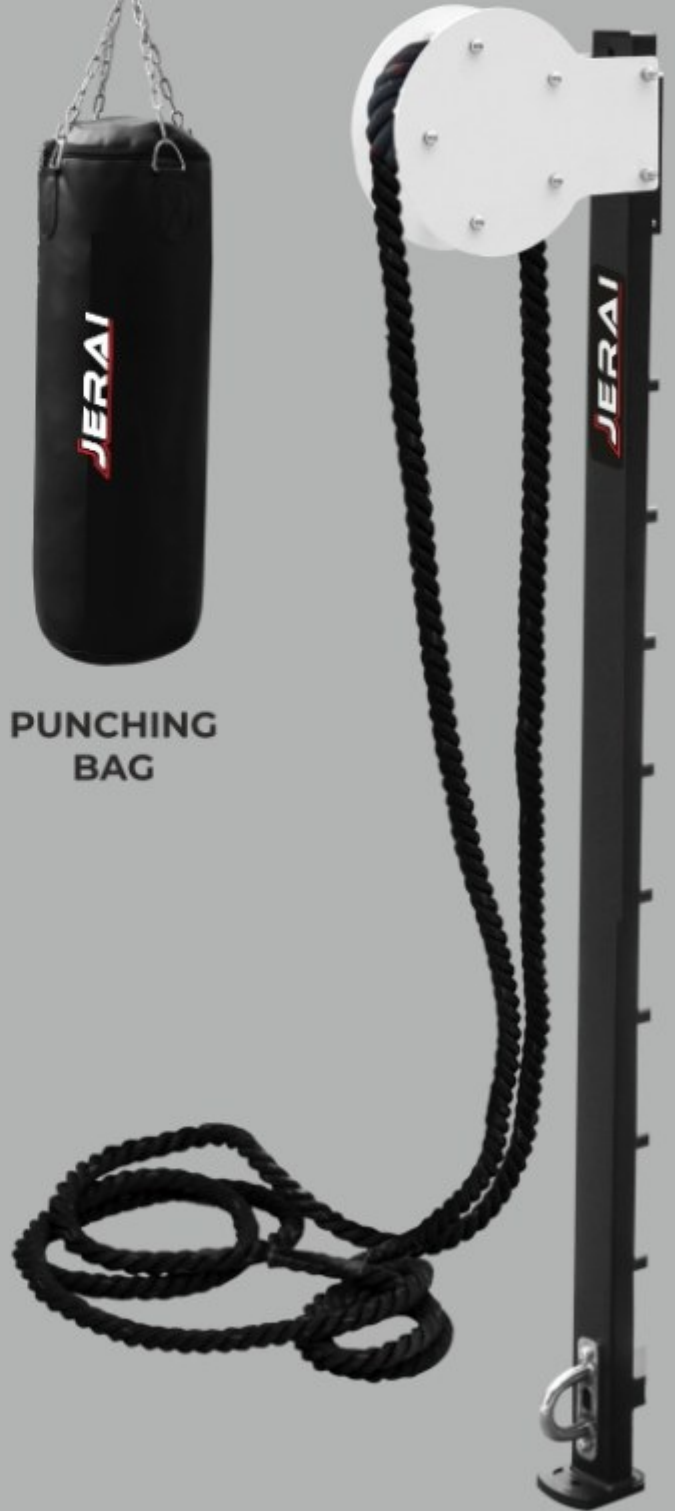

BATTLE ROPE



JX - 4 WAY RIG JX4WR



- ▣ L : 156 inches / 396 cms
- ▣ W : 86 inches / 218 cms
- ▣ H : 108 inches / 274 cms

FEATURES:

- ▶ 4-SIDE POWER RACK STATION
- ▶ 6 TO 14 PULL-UP STATION



JX - MOUNTAIN RIG JXMR



- ▣ L : 288 inches / 731 cms
- ▣ W : 72 inches / 183 cms
- ▣ H : 108 inches / 274 cms

FEATURES:

- ▶ 6 POWER RACK STATION
- ▶ 6 PULL-UP STATION
- ▶ 24 FEET MONKEY BAR STRUCTURE



JX - 4 WALL UNIT JXWU



📏 L : 48 inches / 122 cms
W : 72 inches / 183 cms
H : 108 inches / 274 cms

FEATURES:

- ▶ DUAL PULL-UP STATION
- ▶ WALL-MOUNTED HALF RACK



JX - CUSTOMIZE WALL UNIT

JXWUS



- ▣ L : Customizable
- W : 72 inches / 183 cms
- H : 108 inches / 274 cms

FEATURES:

- ▶ 6 PULL-UP STATION
- ▶ 3 WALL-MOUNTED HALF RACKS



POWER RACK
JXPR1



☑ L : 36 inches / 91 cms
W : 49 inches / 124 cms
H : 100 inches / 254 cms

FEATURES:

- ▶ DUAL SIDE RACK STATION
- ▶ SINGLE PULL-UP STATION



POWER RACK
JXPR2



☑ L : 49 inches / 124 cms
W : 49 inches / 124 cms
H : 100 inches / 254 cms

FEATURES:

- ▶ DUAL SIDE RACK STATION
- ▶ SINGLE PULL-UP STATION



POWER RACK
JXPR3



☑ L : 76 inches / 193 cms
W : 49 inches / 124 cms
H : 100 inches / 254 cms

FEATURES:

- ▶ DUAL SIDE RACK STATION
- ▶ SINGLE PULL-UP STATION
- ▶ WEIGHT STORAGE HOLDERS

FRAME

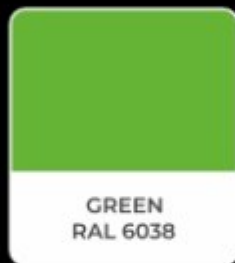

UPHOLSTERY

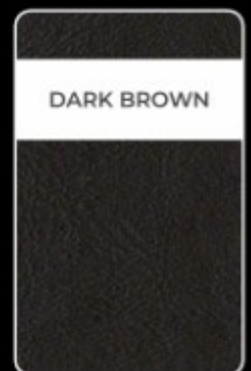
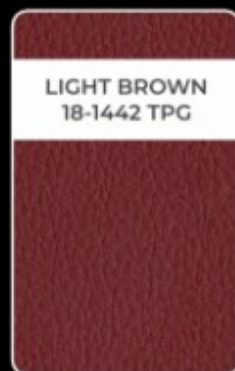
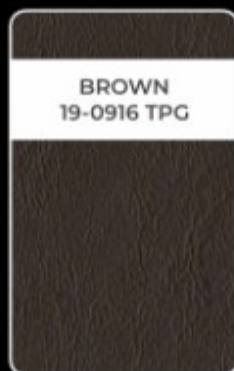
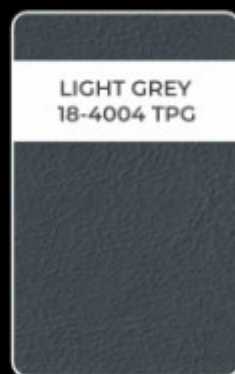

JERAI[®] **FITNESS LTD.**

A PIONEER IN FITNESS EQUIPMENT MANUFACTURING.



+91 86579 64733

+91 91520 04941

Website: www.jeraifitness.com / www.jeraihomegym.com

Email: sales@jeraifitness.com

Connect with us on   

Registered Office: D - 204, Gagangiri Complex, New Link Road, Near Mcdonald's, Kandarpada, Dahisar (west), Mumbai - 400 068, Maharashtra, INDIA.

Corporate Office: 209 - 212, Techno IT Park, Link Road, Borivali (West), Mumbai - 400 092, Maharashtra, INDIA.

Factory: Survey 215, Plot No. 08, 09, 13, 14, 18, 19, 22, and 23 of Survey No. 216 (P), Survey 217, Survey 218 (P), Unit No. 3A, 05, and 06 of Survey 219, Village Ghonsai, Wada, Palghar - 421 303, Maharashtra, INDIA.

Jerai Fitness Ltd. reserves the right to modify its products, specifications, and documentation at any time without prior notice. All trademarks, product names, and patents are the property of Jerai Fitness Ltd., in India and internationally. © Jerai Fitness Ltd., 2025. All rights reserved. All training structures, including indoor and outdoor rigs or wall-mounted setups, must be securely installed using appropriate fasteners. Installation and anchoring are the sole responsibility of the customer. Jerai Fitness Ltd. shall not be held liable for any injury, damage, or loss resulting from improper installation, misuse, or failure to follow safety guidelines.