



Parametric BIM Family Creation & Architectural Component Library Development for QSR Projects

(BIM Family Creation & Component Development, BIM Content Standardization Services)

CASE STUDY



TECHTURE



Client : Design Consultant

Team Size : 2 No.s (BIM Engineer & BIM Coordinator)

Disciplines : Architectural, Interior, Electrical & Plumbing

Duration : 3 Weeks

Type : Retail

Software : Autodesk Revit 2024

Location : Texas, USA

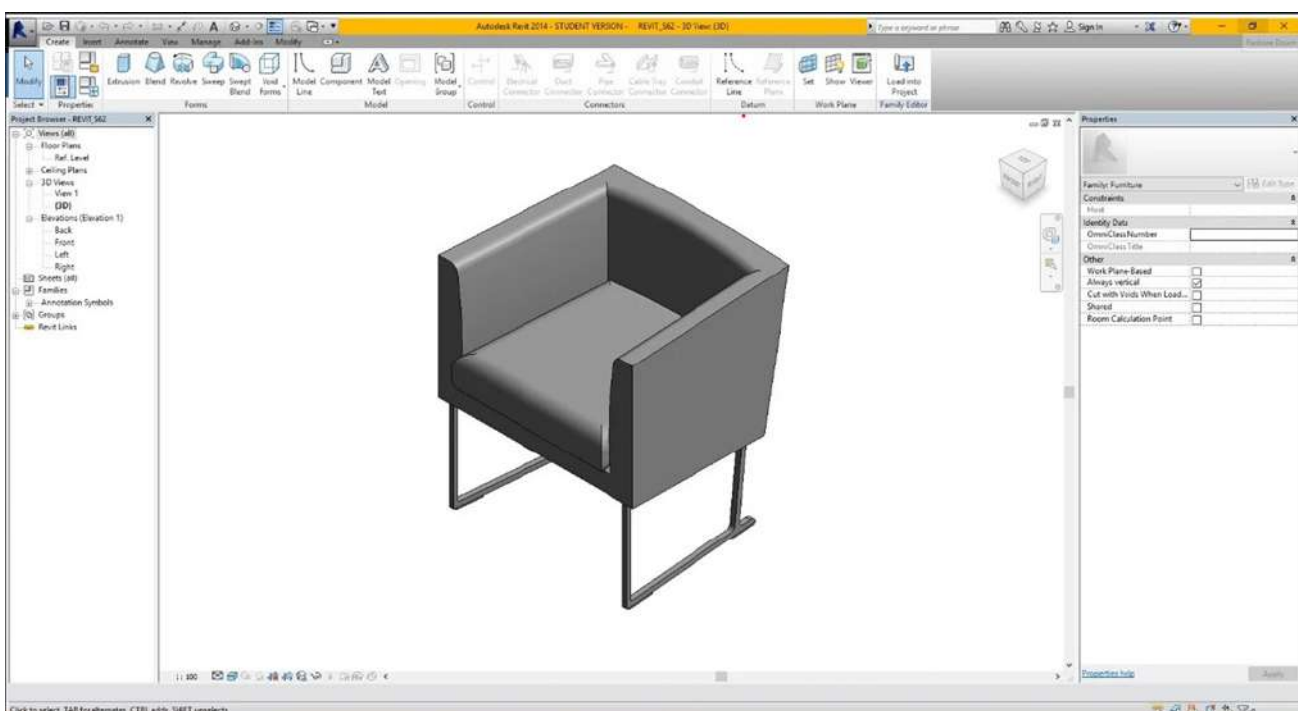

Project Overview

Techture delivered parametric BIM family creation and architectural component library development for QSR retail projects using Autodesk Revit 2024. The scope focused on building a standardized, reusable library of 3D and 2D components across Architectural, Interior, Electrical, and Plumbing disciplines. The families were developed to ensure consistency, scalability, and efficient project execution. The solution enabled faster modeling workflows and improved design standardization across multiple projects.

Scope & Deliverables

- Develop parametric Revit families for Architectural, Interior, Electrical & Plumbing components.
- Create 3D & 2D components including site elements, furniture, fixtures, walls & details.
- Organize families under walls, doors & windows, ceilings, furniture, and detail categories.
- Model lighting fixtures, plumbing fixtures, signage, and specialty architectural elements.
- Deliver standardized BIM library with one iteration based on client feedback inputs.

Challenges

- Managing large-scale component library with diverse element categories.
- Ensuring consistency across multi-discipline parametric family standards.
- Balancing detail level for performance optimization and usability efficiency.

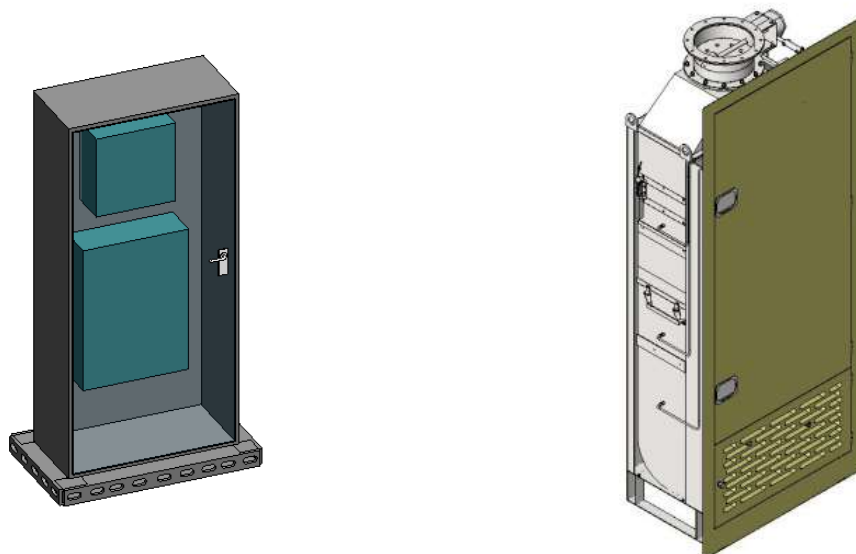

Techture Approach

- ❏ Developed high-quality parametric families with standardized naming conventions.
- ❏ Structured library for easy reuse across multiple retail project typologies.
- ❏ Incorporated client inputs to align families with brand and design standards.
- ❏ Ensured optimized geometry for performance and efficient model handling.

Benefits

- ❏ Accelerated modeling with ready-to-use standardized BIM component library.
- ❏ Improved consistency across Architectural, Interior, Electrical & Plumbing elements.
- ❏ Reduced rework through parametric and scalable family creation approach.
- ❏ Enhanced project efficiency with optimized and reusable BIM assets.

