



LOD 400 Fire BIM Modeling & Coordination for Large-Scale Data Center

(Fire Protection BIM Modeling, Shop Drawing Development & BIM & VDC Coordination Services)

CASE STUDY



TECHTURE

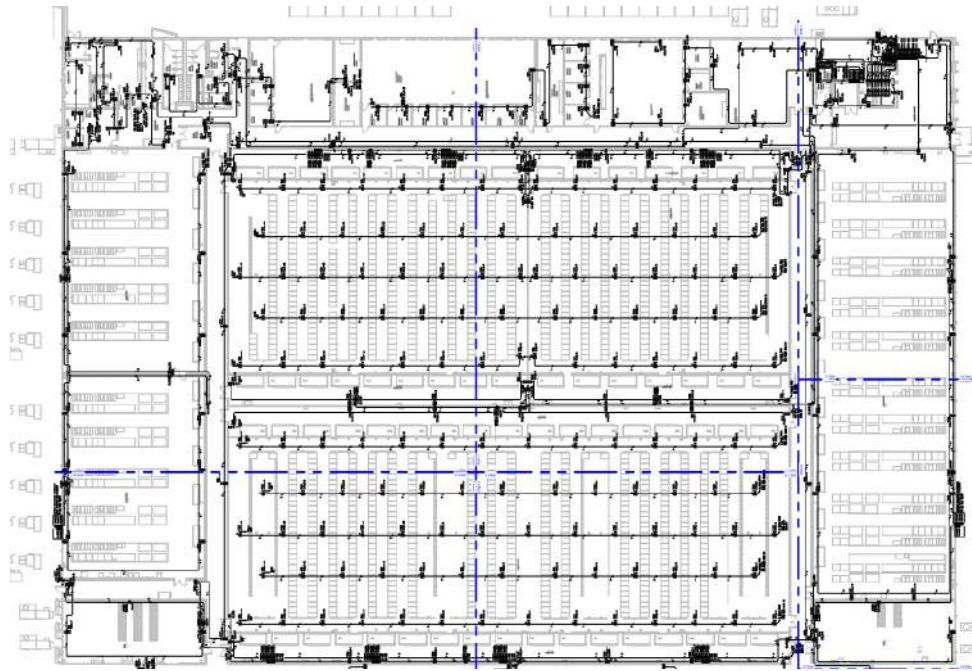

Client : Engineering Consultant

Team Size : 5 No.s (BIM Engineer & BIM Coordinator)

Disciplines : Fire

Duration : 3 Month

Scale : 800,000 Sq. Ft.

Software : Autodesk Revit & Navisworks

Type : Data Center

Location : Texas, USA

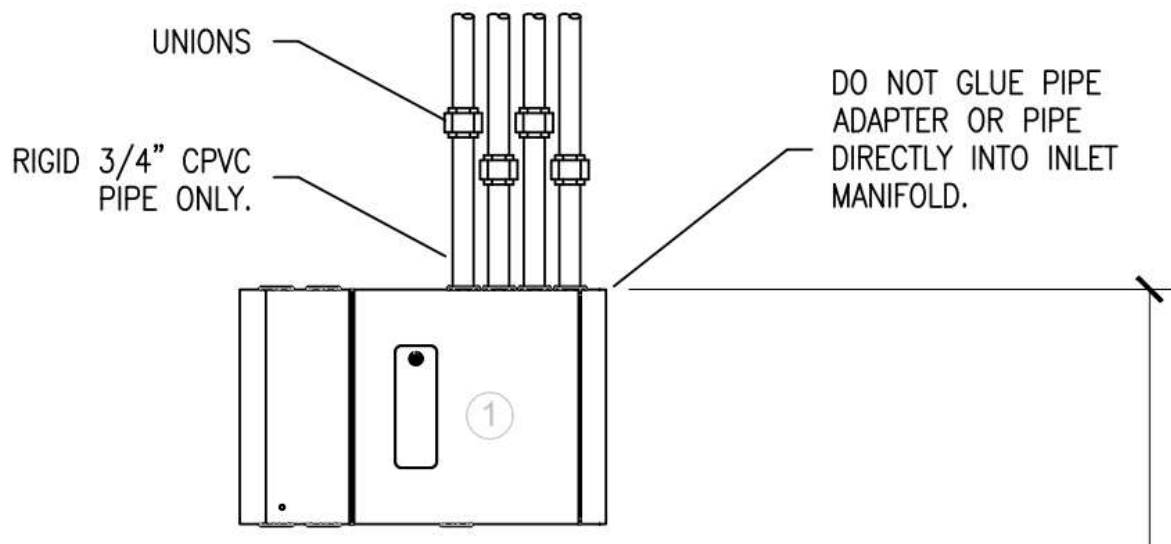

Project Overview

Techture delivered LOD 400 Fire BIM modeling and coordination for an 800,000 Sq. Ft. large-scale data center project. The scope focused on developing detailed fire protection systems, including fire alarm and VESDA networks, based on design inputs. Using Autodesk Revit and Navisworks, the team ensured coordinated, clash-free models aligned with multi-disciplinary systems. The outcome supported precise installation and high-performance safety infrastructure.

Scope & Deliverables

- 📦 Develop LOD 400 Fire BIM model based on design drawings and client inputs.
- 📦 Model fire alarm systems, VESDA networks, and associated fire protection components.
- 📦 Perform clash detection with ASMEP, Architecture & Structure models.
- 📦 Update model based on coordination meetings, RFIs, and approved resolutions.
- 📦 Generate coordinated fire shop drawings from finalized BIM model outputs.

Challenges

- 📦 Coordinating fire systems within high-density data center environments.
- 📦 Ensuring accuracy for critical fire alarm and VESDA system layouts.
- 📦 Managing coordination across multiple disciplines and large-scale models.

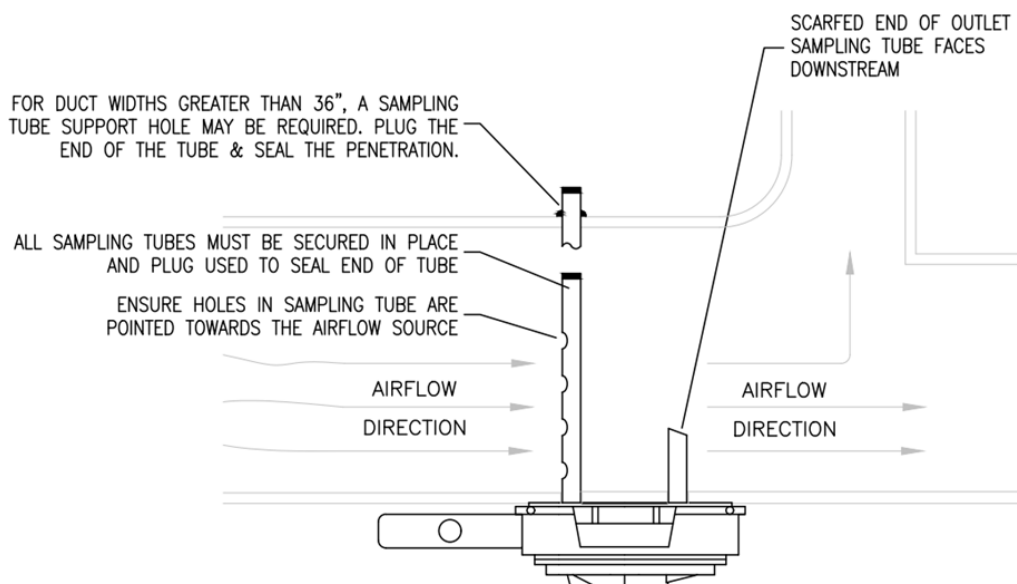

Techture Approach

- Developed high-detail LOD 400 fire models aligned with design specifications.
- Conducted structured clash coordination with multi-disciplinary BIM models.
- Implemented RFI-based resolution workflows for model validation.
- Extracted shop drawings directly from coordinated and clash-free BIM models.

Benefits

- Delivered fabrication-ready fire protection BIM models and drawings.
- Enhanced safety planning with accurate fire alarm and VESDA layouts.
- Reduced coordination conflicts through clash detection and resolution workflows.
- Improved execution efficiency using coordinated BIM-driven deliverables.

