

T2SL Balder

Experience the revolution. IRnova eSWIR T2SL technology, originally designed for space, now on the market at VGA level.

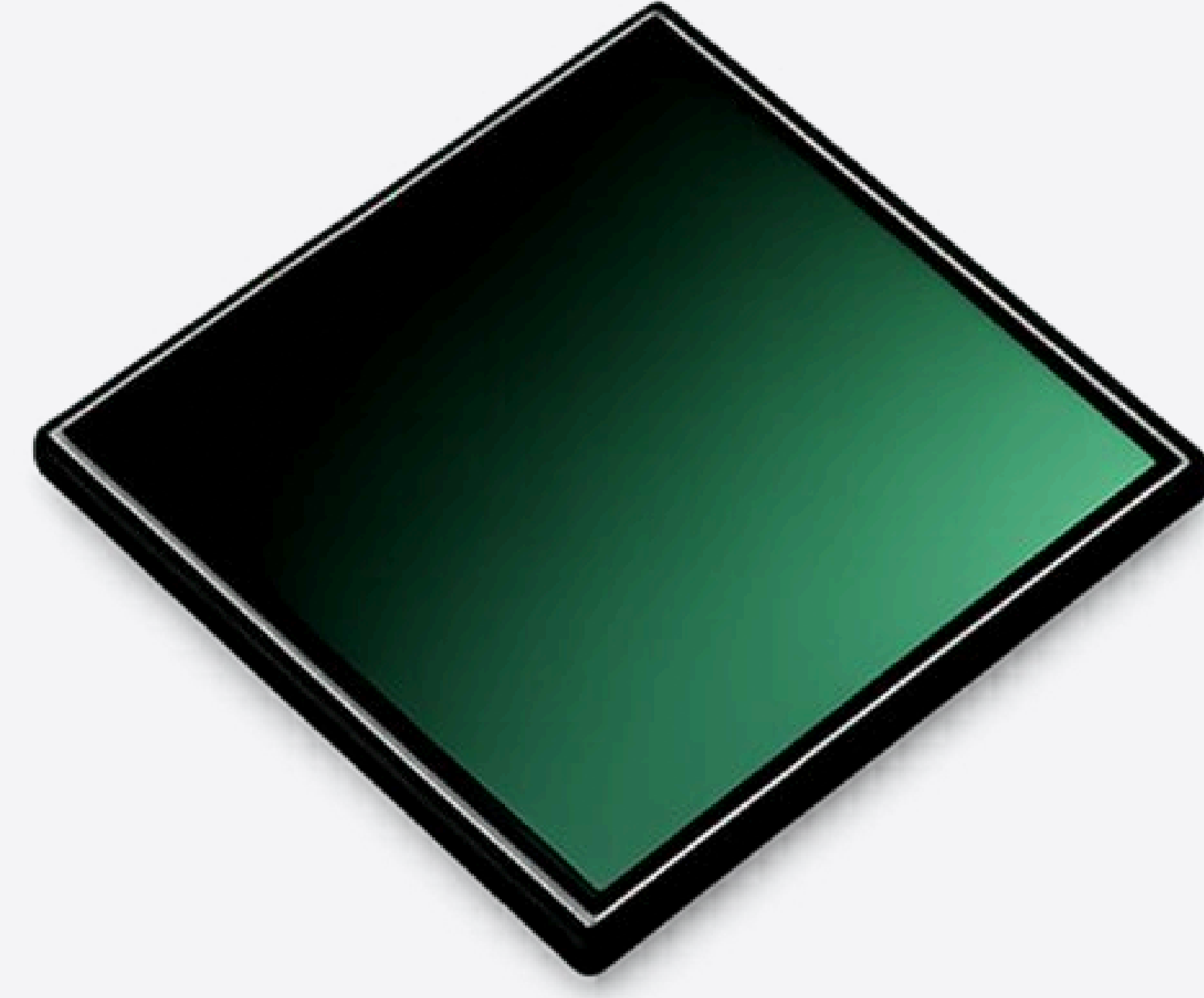

Balder FPA
eSWIR T2SL



Balder SL
eSWIR T2SL - K588



Balder
eSWIR T2SL - RMs1

Description

With the Balder, IRnova's T2SL now brings the ultimate sensitivity, uniformity, stability, and resolution to the full shortwave spectral range. The detector is available in three formats: SWaP rotary, SWaP split linear, and also in FPA format for manufacturers wishing to integrate into a TEC-cooled system.

Applications

- ✓ Space monitoring
- ✓ Machine vision
- ✓ Enhanced visibility through degraded environments
- ✓ Industrial monitoring
- ✓ Active imaging with SWIR light source
- ✓ Spectrometry

General information

Application: General purpose

Format: 640x512

Technology: T2SL

Pixel pitch: 15 μ m

Typical detector performance

Spectral range: 0.9 - 2.5 μ m

Pixel operability: 99.9%

F number options: F/1.2, F/2

Dark current at 180 K: <0.5 μ A/cm²

PRNU: < 2%

MTF at Nyquist: > 60%

Spectral response

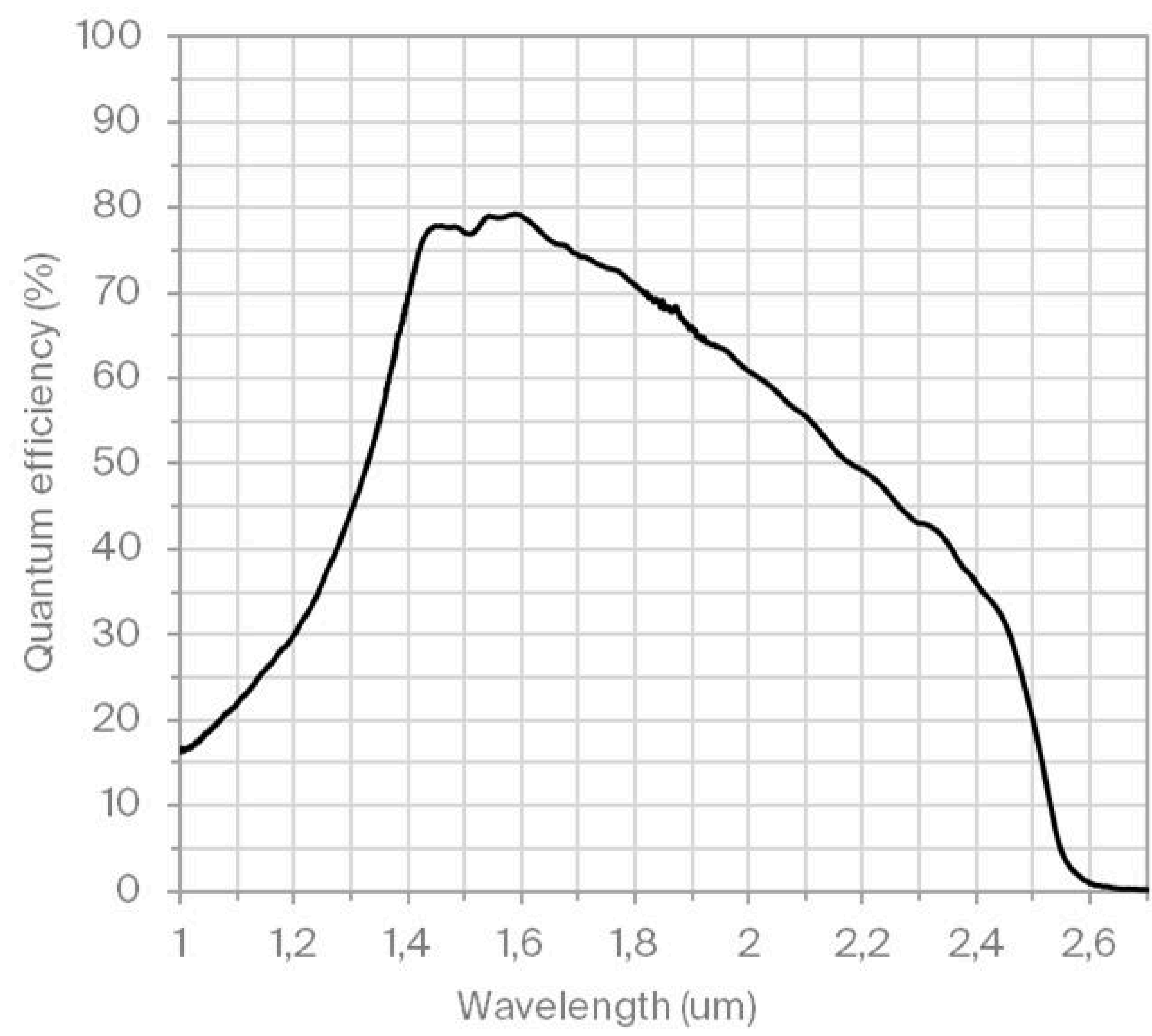

Read-out electronics

Read-out modes : Windowing, ITR IWR and IMRO

Supply voltage: 5 V

Frame rate: up to 300 Hz @ full resolution

Electrical interfaces: Camera Link
Cooler control and proximity electronics included

IDDCA Parameters

Cooler options: RMs1 or K588

Weight: 240g (RMs1), 330g (K588)

Power consumption: < 2 W
Without proximity electronics

Dimensions: 143x76x62 mm

Cool down time: 3.5 min

Cooler MTTF: > 15 000h (RMs1), >35 000 (K588)

Cooler voltage: 12 V

Environmental conditions: MIL-STD-810

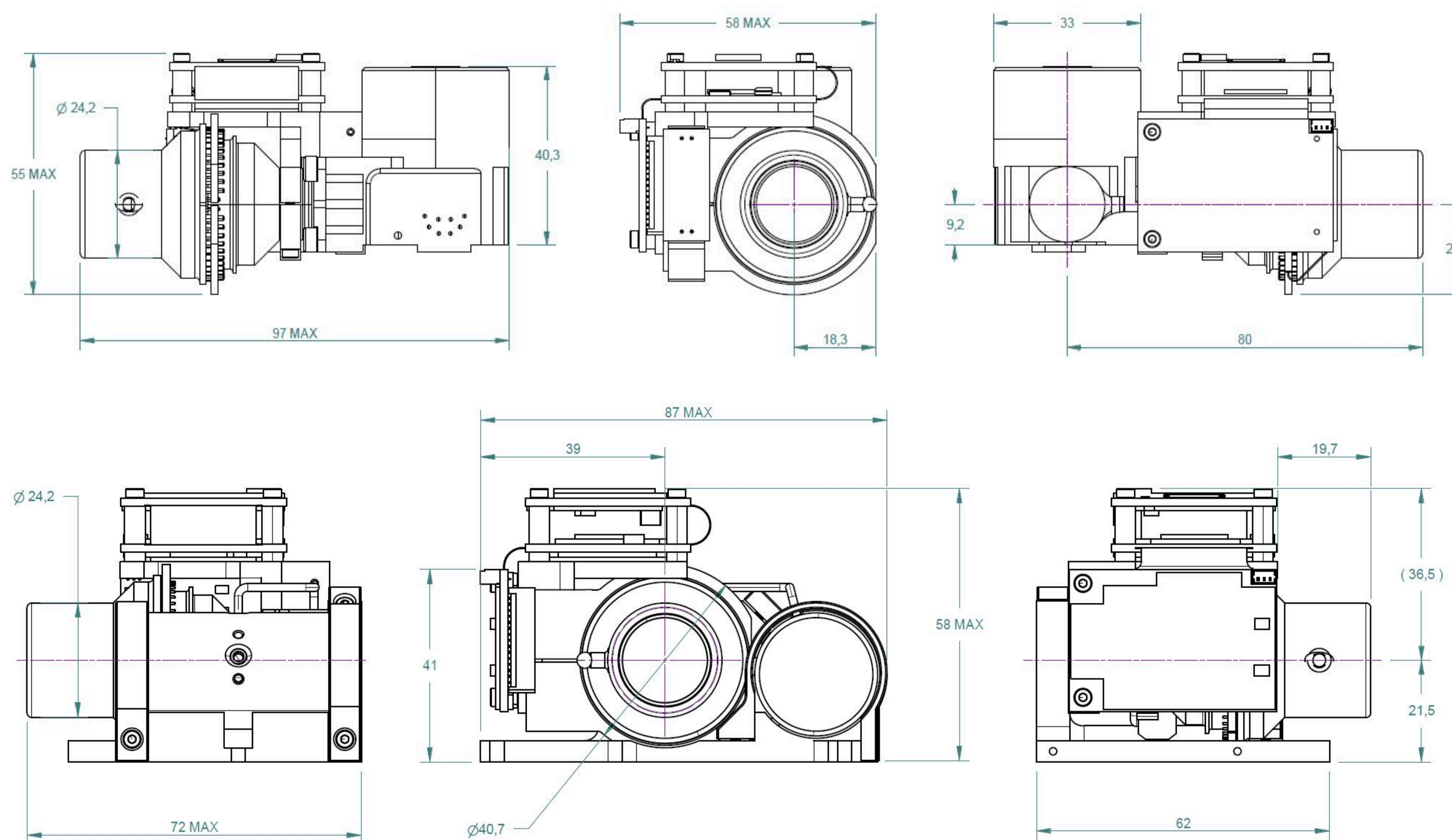

Technical characteristics described above are not contractual and may change without prior notice. This is revision 1.0