

T2SL Freja 460

One of the higher spectral ranges in the Freja product range, the Freja 460 delivers highly uniform optical gas imaging for carbon monoxide (CO). Choose this detector for handheld and battery-operated cameras and feel the benefits of IRnova's pioneering T2SL technology.

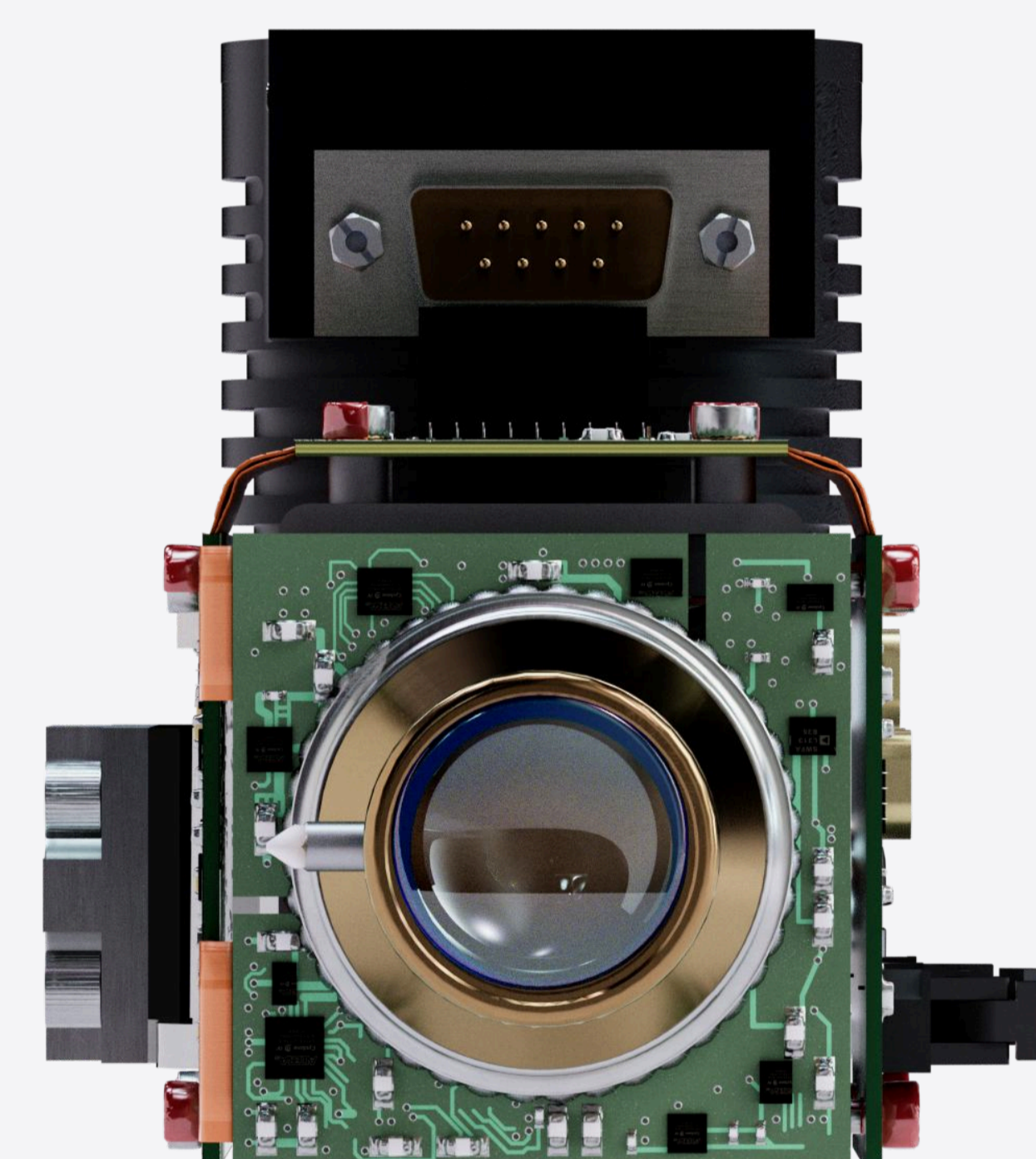
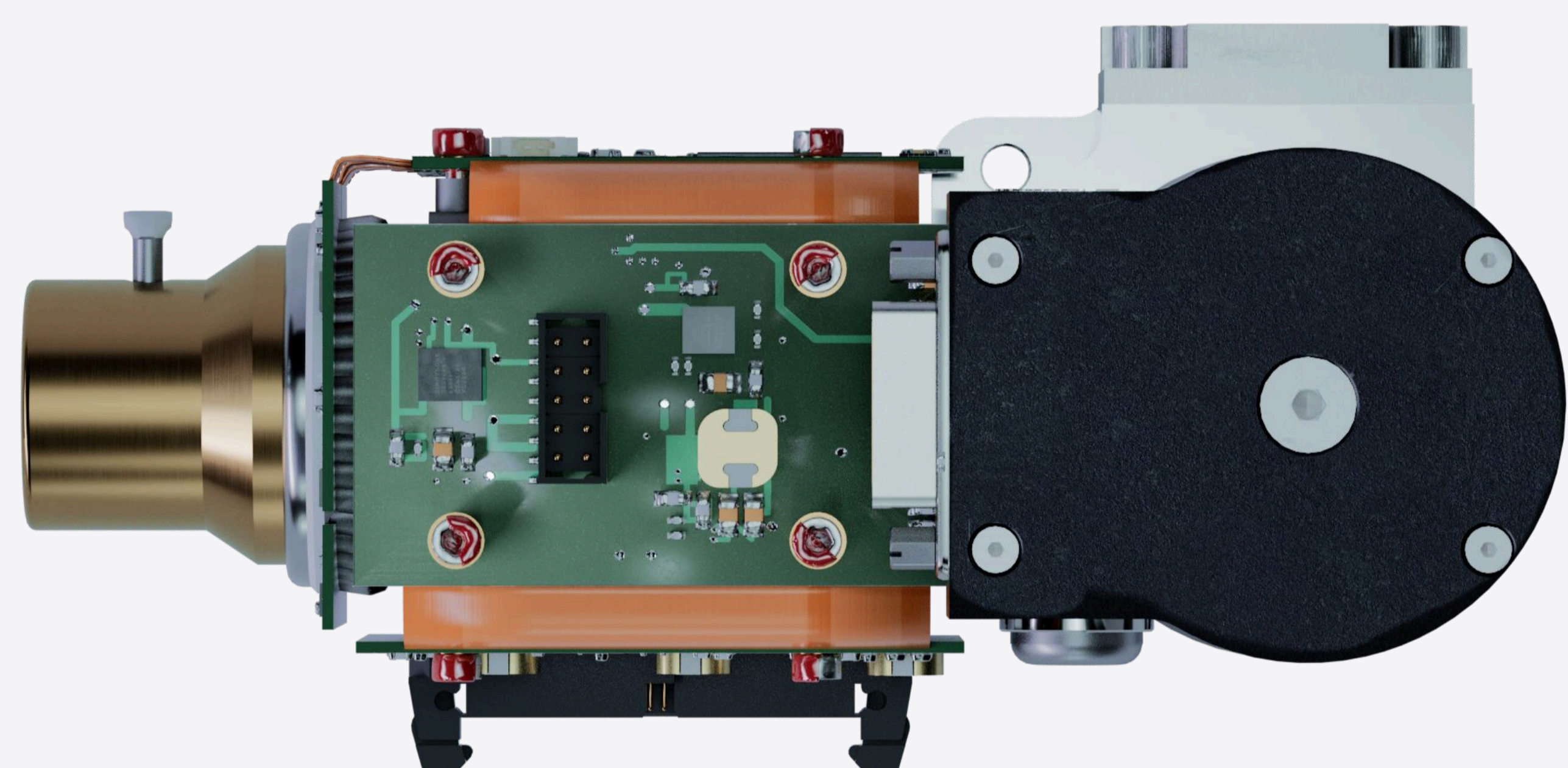
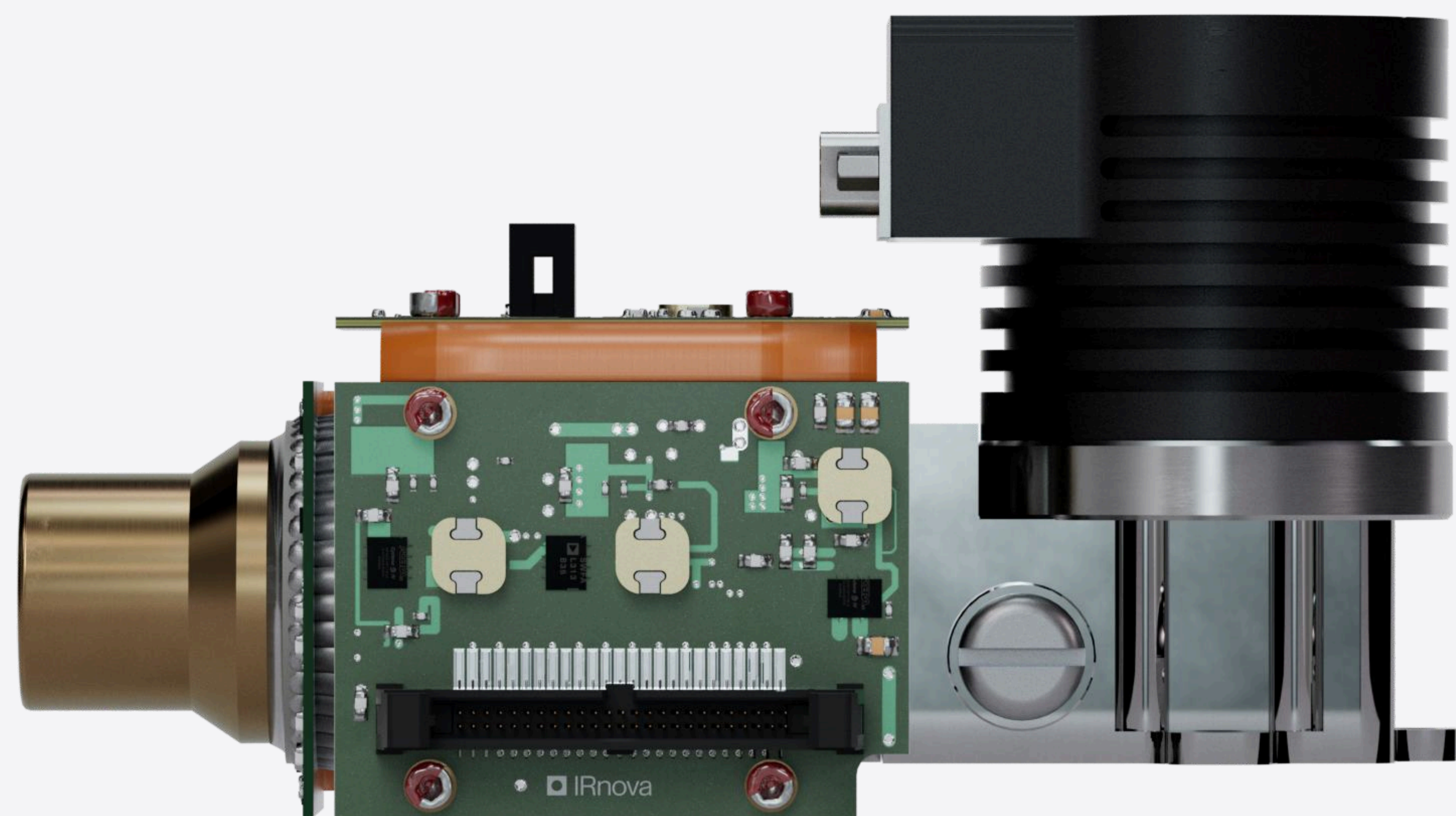

Description

Freja 460 detector takes advantage of IRnova's T2SL technology breakthrough and a wide F/1.2 optical aperture to provide best-in-class gas detection capability for carbon monoxide having its absorption peak near 4.6 μ m.

Applications

- ✓ Optical gas imaging for any gas with absorption in the 4.6 μ m range
- ✓ Optimized for carbon dioxide (CO₂) detection
- ✓ Handheld and battery powered cameras
- ✓ Mobile and stationary platforms

General information

Application: Gas & pollution detection

Format: 320x256

Technology: T2SL

Pixel pitch: 30 μm

Typical detector performance

Spectral range: 4.5 - 4.7 μm

Pixel operability: 99.9 %

F number options: F/1.2

MTF: 64 %
@ Nyquist frequency

NETD: 10 mK @F/1.2, 30 Hz

Proximity electronics

Supply voltage: 12 V

Electrical interfaces: Camera Link
Cooler control and proximity
electronics included

Maximum frame rate: 60 Hz

IDDCA Parameters

Cooler options: RM3i, K508, K508N,
SRI401

Weight: 590 g

Power consumption: 5.5 W
Without proximity electronics

Dimensions: 133x76x68 mm

Cool down time: 3 min

Cooler MTTF: >50 000 h

Cooler voltage: 12 V
24 V options available

Environmental conditions: MIL-
STD-810

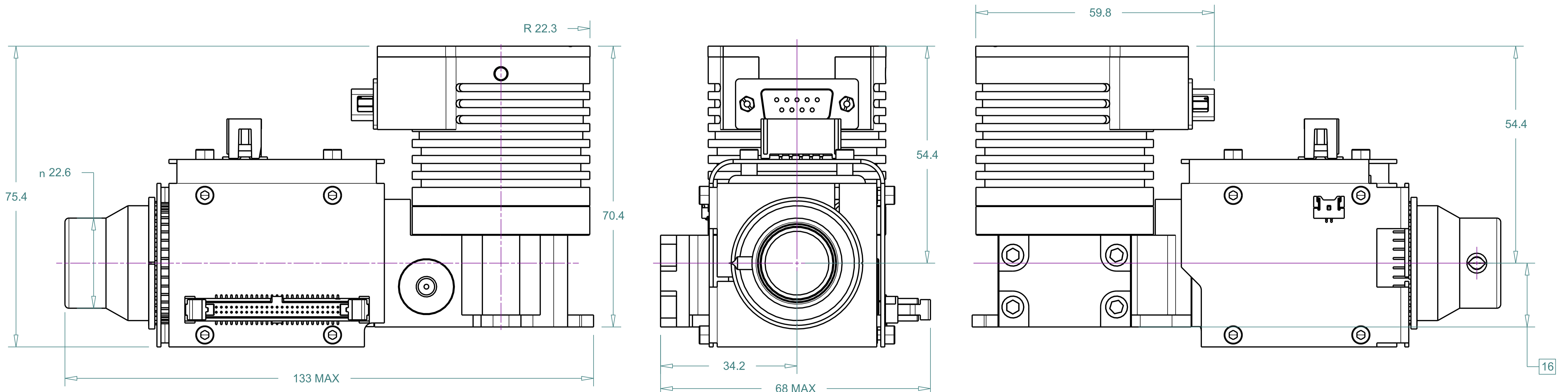

Technical characteristics described above are not contractual and may change without prior notice. This is revision 1.0.