

T2SL Hnoss 330 LLT

The Hnoss 330 LLT, equipped with our advanced T2SL technology and 640x512 resolution, transforms optical gas imaging (OGI). Optimised for fixed and mobile installations, it boasts a long-life cooler and the increased resolution allows for a large field of view.

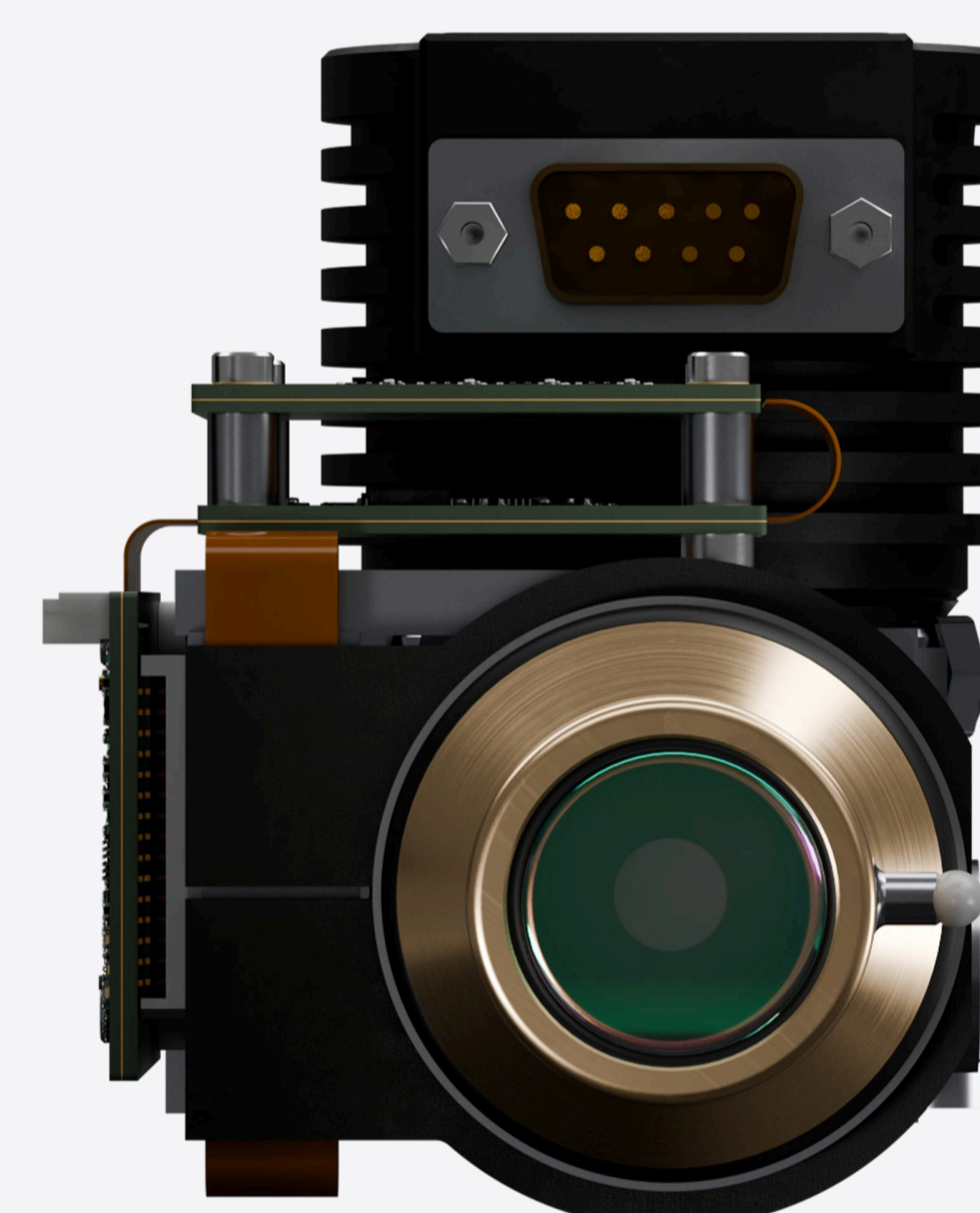
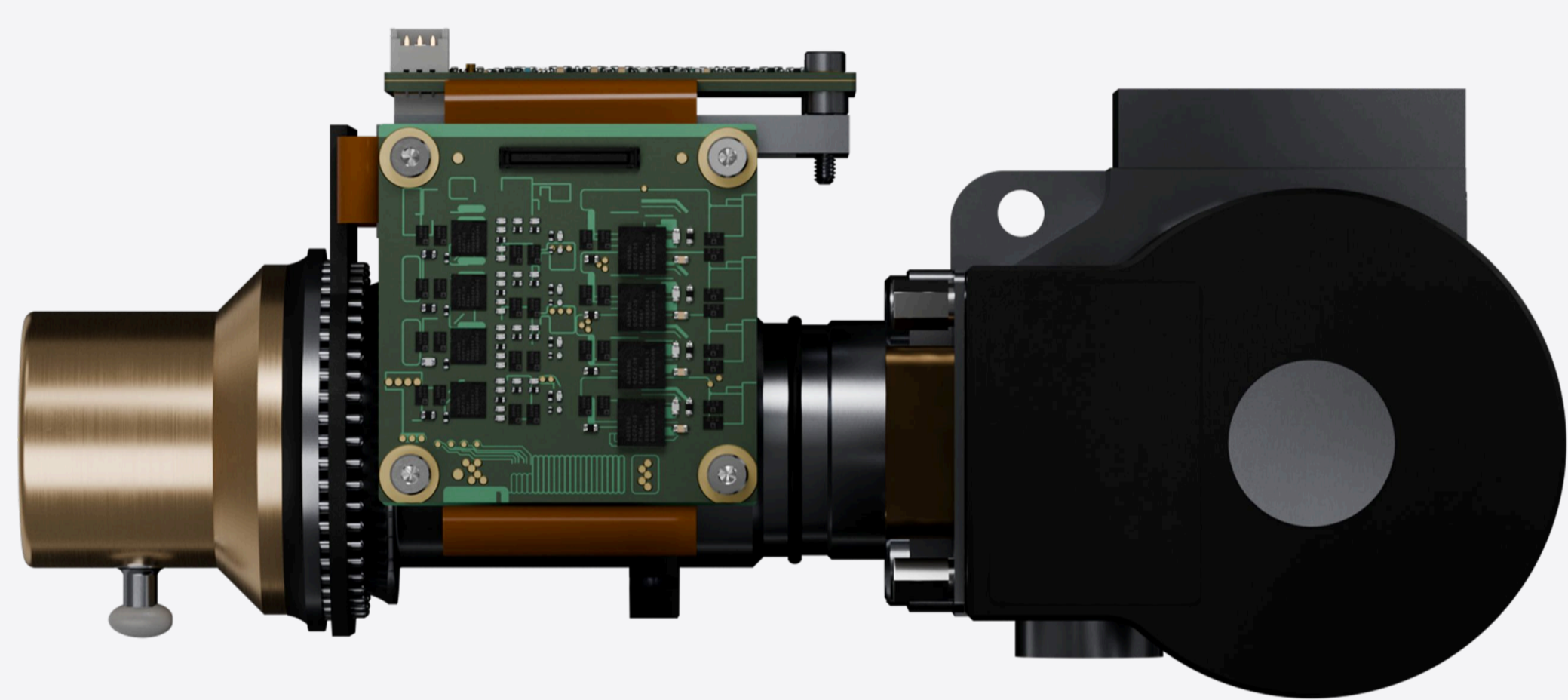
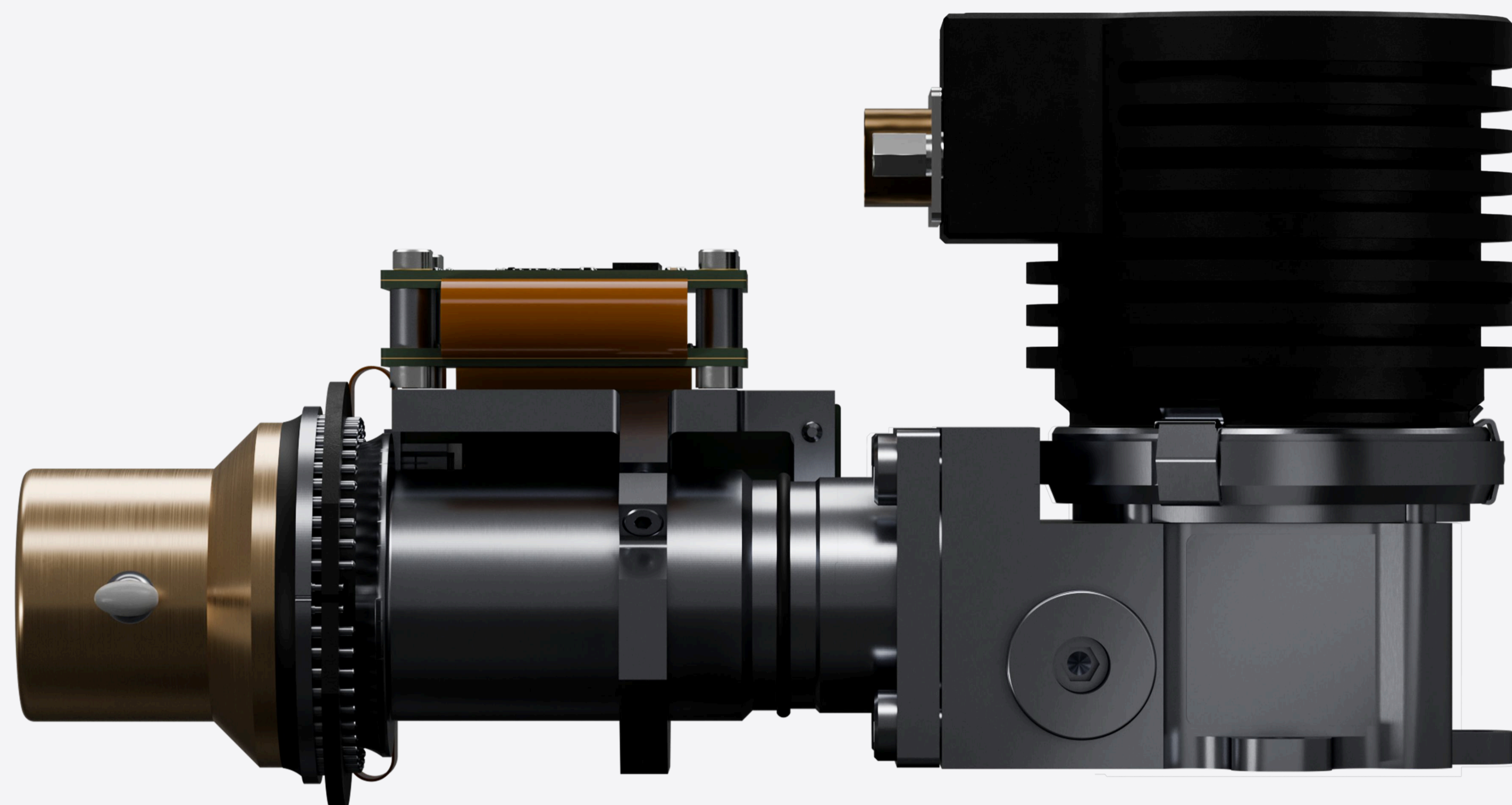

Description

The T2SL Hnoss 330 LLT offers unmatched sensitivity and image clarity. Its large field of view makes the Hnoss 330 LLT ideal for both mobile and stationary platforms and 24/7 monitoring. Whether detecting methane, ethane, propane, or other VOC gases, the Hnoss 330 LLT is engineered for precision and reliability, redefining OGI standards in the spectral range of 3.3 μm .

Applications

- ✓ Optical gas imaging for any gas with absorption in the 3.3 μm range
- ✓ Optimized for detection of methane, ethane, propane and other VOC gases
- ✓ Mobile and stationary platforms
- ✓ Fixed 24/7 large area surveillance
- ✓ Handheld and battery powered cameras

General information

Application: Gas & pollution detection

Format: 640x512

Technology: T2SL

Pixel pitch: 15 μm

Typical detector performance

Spectral range: 3.2 - 3.4 μm

Pixel operability: 99.9 %

F number options: F/1.2

MTF: 62 %
@ Nyquist frequency

NETD: 16 mK @ F/1.2, 30 Hz

Proximity electronics

Supply voltage: 5 V

Electrical interfaces: Camera Link

Maximum frame rate: 60 Hz
120 Hz optional

Cooler control and proximity
electronics included

IDDCA Parameters

Cooler options: RM3i, K508, K508N,
SRI1401

Weight: 590 g

Power consumption: 3 W
Without proximity electronics

Dimensions: 133x76x66 mm

Cool down time: 3 min

Cooler MTTF: >50 000 h

Cooler voltage: 12 V
24 V options available

Environmental conditions: MIL-
STD-810

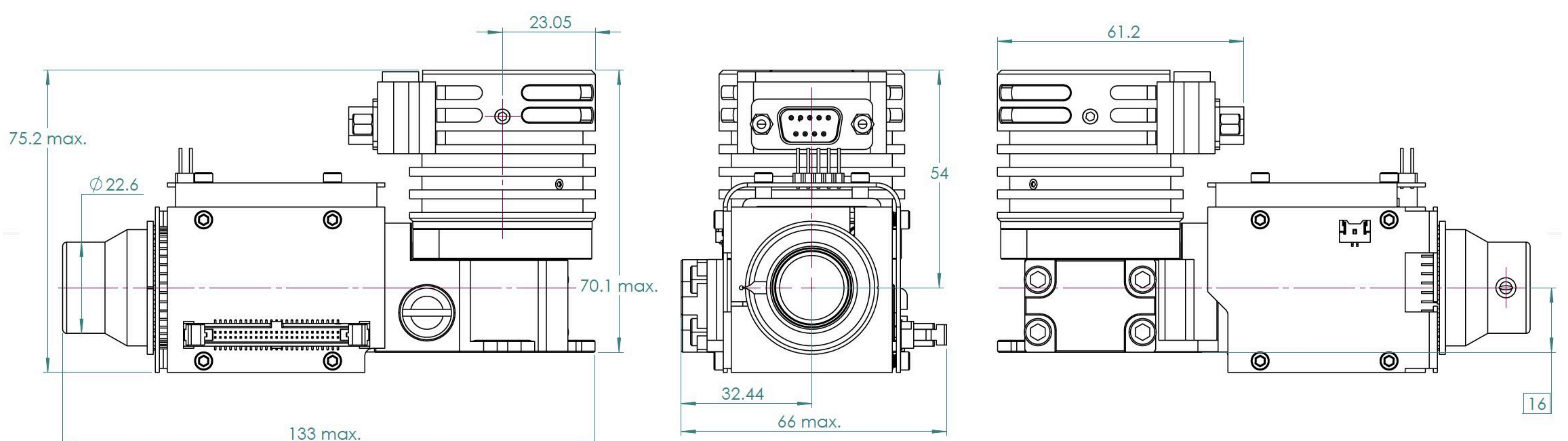

Technical characteristics described above are not contractual and may change without prior notice. This is revision 1.0