

# T2SL Njord

T2SL Njord is a 1280x1024, 10  $\mu\text{m}$  pixel pitch SWaP MWIR detector pioneering our exciting HD format roadmap.

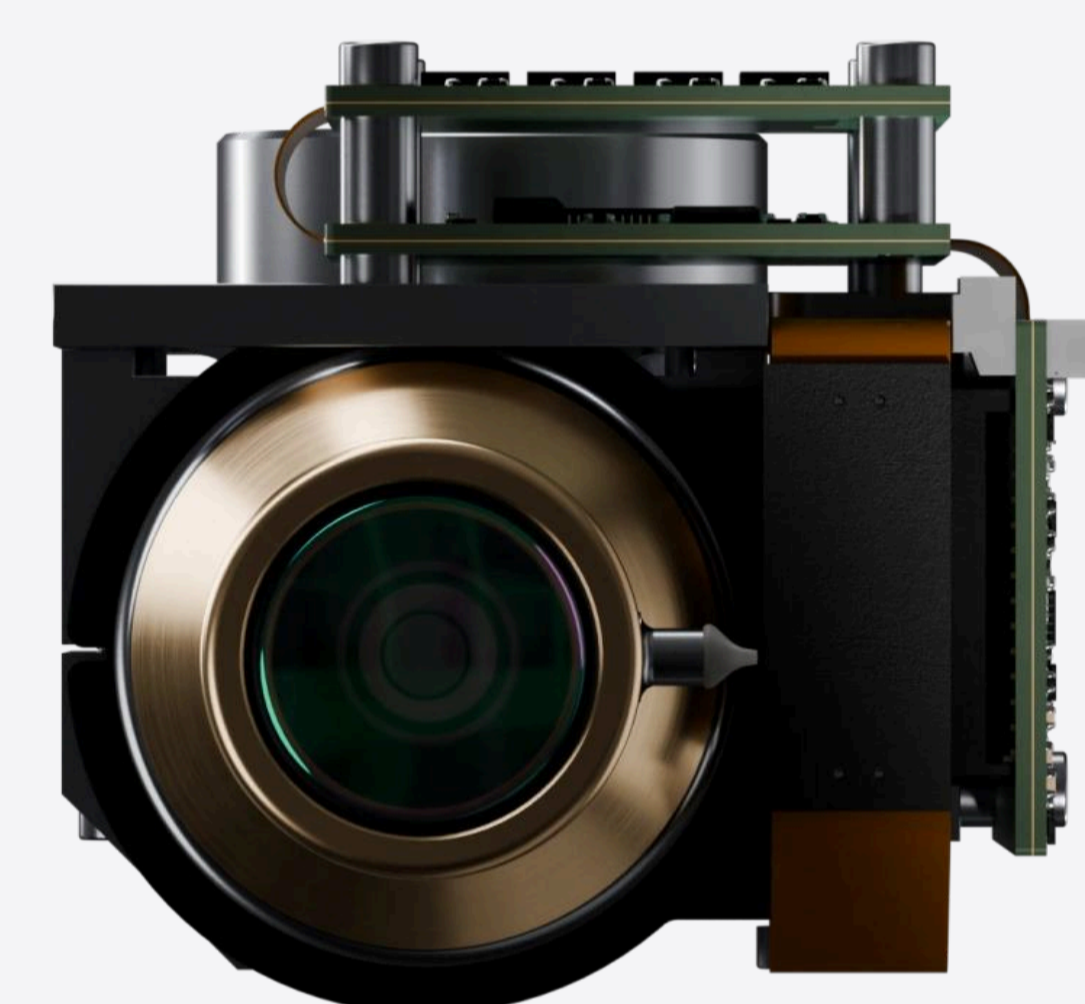
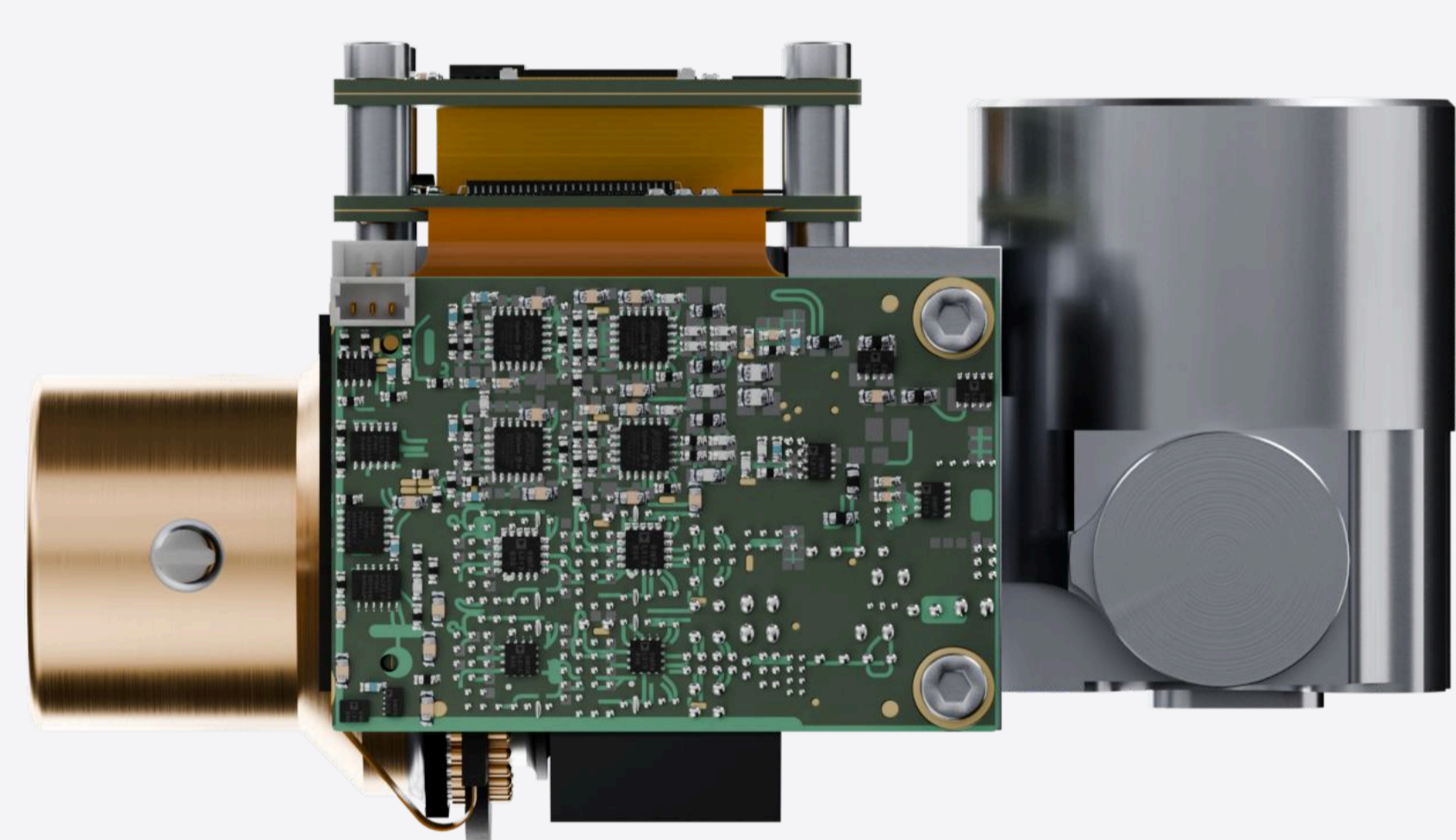
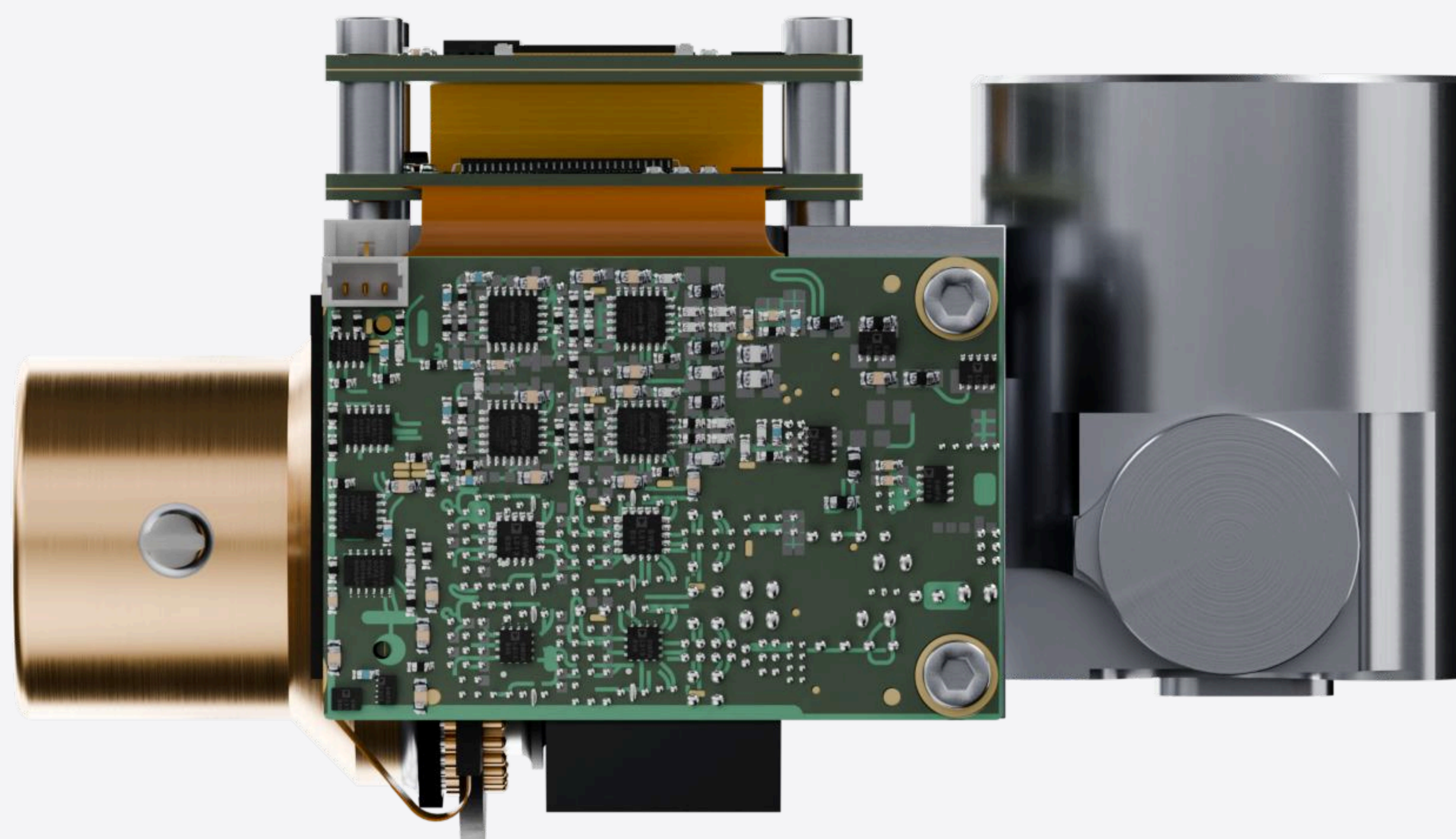

## Description

T2SL Njord is a 1280x1024, 10  $\mu\text{m}$  pitch T2SL detector serving demanding MWIR applications. Our ground breaking T2SL technology combines all the long awaited key benefits (high resolution, high quantum efficiency over the full 3-5  $\mu\text{m}$  spectrum, low NETD, unprecedented array uniformity and operability, all within outrageous SWaP (Size, Weight and Power) footprint.

## Applications

- ✓ Long range security & surveillance
- ✓ Space constrained systems (UAV gimbals, compact multisensor systems)
- ✓ High performance ISR and targeting airborne gimbals
- ✓ Handheld and battery powered systems (goggles, portable cameras)
- ✓ Mobile and stationary platforms

## General information

Application: General purpose

Format: 1280x1024

Technology: T2SL

Pixel pitch: 10  $\mu\text{m}$

## Typical detector performance

Spectral range: 3.7 - 5.1  $\mu\text{m}$   
CO2 notch filter optional

Pixel operability: 99.9 %

F number options: F/2, F/3.4, F/4

MTF: 61 %  
@ Nyquist frequency

NETD: 25 mK @ F/4, 60 Hz

## Proximity electronics

Supply voltage: 5 V

Electrical interfaces: Camera Link

Maximum frame rate: 60 Hz

Cooler control and proximity electronics included

## IDDCA Parameters

Cooler options: RMs1, K580

Weight: 260 g

Power consumption: 2 W  
Without proximity electronics

Dimensions: 97x58x55 mm

Cool down time: 4 min

Cooler MTTF: 12 500 h

Cooler voltage: 12 V

Environmental conditions: MIL-STD-810

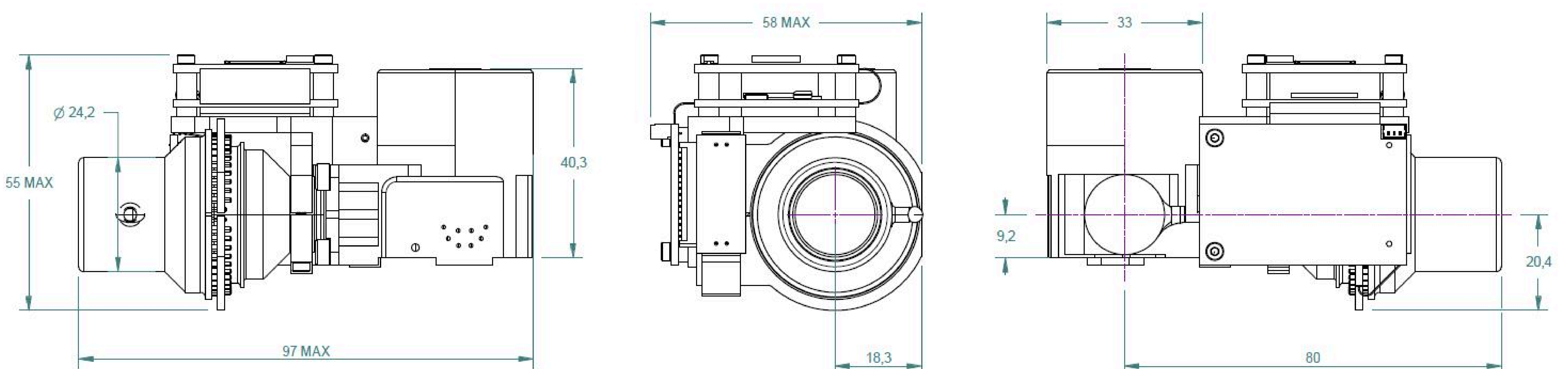

Technical characteristics described above are not contractual and may change without prior notice. This is revision 1.0