

# Price list 2026



The products



Showtime 3



Slide 7



Slide Connect 19



Spark 29



Upsite 35



Pace 43



Star 49



Talk 57



Convo 65



Tune 75









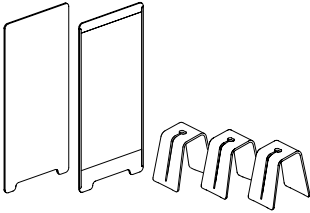
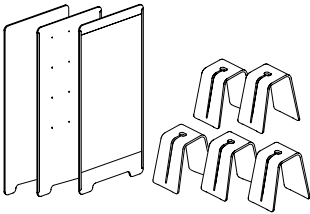
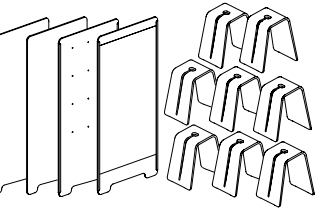
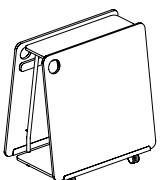

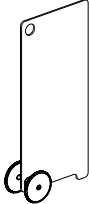
Site 85

# SHOWTIME



		Dim. in cm W D H	HPL white High gloss	HPL white	PET- fleece	Birch natural	Birch stained  - white - lemon - coral - berry - lagoon - sage - olive
<p><b>START-UP</b></p> 	<p>Set consisting of:</p> <ul style="list-style-type: none"> <li>- 3 x Woody stool natural</li> <li>- 2 x Board (selectable from Q 20 B1/B2/B3)</li> <li>- 1 x presentation set</li> </ul> <p>The Woody stool in natural birch is the basis, the birch stained version or a Soft Seat is available at additional cost. The boards (Flying Board, Magnetic Board or Silent Board) can be selected individually</p>		3.566				
<p><b>IDEA LAB</b></p> 	<p>Set consisting of:</p> <ul style="list-style-type: none"> <li>- 5 x Woody stool natural</li> <li>- 3 x Board (selectable from Q 20 B1/B2/B3)</li> <li>- 1 x presentation set</li> </ul> <p>The Woody stool in natural birch is the basis, the birch stained version or a Soft Seat is available at additional cost. The boards (Flying Board, Magnetic Board or Silent Board) can be selected individually</p>		5.484				
<p><b>WORKSHOP</b></p> 	<p>Set consisting of:</p> <ul style="list-style-type: none"> <li>- 8 x Woody stool natural</li> <li>- 4 x Board (selectable from Q 20 B1/B2/B3)</li> <li>- 1 x presentation set</li> </ul> <p>The Woody stool in natural birch is the basis, the birch stained version or a Soft Seat is available at additional cost. The boards (Flying Board, Magnetic Board or Silent Board) can be selected individually</p>		7.862				
<p><b>Q 50</b></p> 	<p><b>Workstation</b></p> <p>Transport and presentation trolley for up to 8 Flying, Magnetic or Silent Boards</p>	100 65 108	2.649				

			Dim. in cm W D H	HPL white High gloss	PET- fleece	HPL white	Birch natural	Birch stained  - white - lemon - coral - berry - lagoon - sage - olive	
	Q 10	<b>Roller Board</b> Free standing, mobile whiteboard with 2 wheels	88 32 180	1.320					
	Q 20 B1	<b>Flying Board</b> Portable, lightweight whiteboard	80 1,5 180	998					
	Q 20 B2	<b>Magnetic Board</b> Portable, lightweight whiteboard made of PET fleece with magnetic, writable surface on both sides	80 1,5 180		998				
	Q 20 B3	<b>Silent Board</b> Portable, light whiteboard made of PET fleece prepared for up to 12 magnetic dots	80 1,5 180		998				
	Q 28	<b>Magnetic Dots</b> Set of 3, 1 x each in yellow (RAL 1018), coral (RAL 2001) and lagoon (RAL 6034)	Ø 7						154
	Q 30 S	<b>Woody</b> Birch molded wooden stool with inclined seat, non-slip lacquered surface/standing tool for whiteboards	41 52 58				460	548	
	Q 30 E	<b>Single price</b> (outside a set)					615	704	
	Q 30 S	<b>Woody with Soft Seat</b> Birch molded wooden stool with inclined seat, incl. a felt seat cushion anthracite/standing tool for whiteboards					584	672	
	Q 30 E	<b>Single price</b> (outside a set)					740	828	
	Q 29	<b>Presentation Set</b> 4 pens in a case + 1 cleaning cloth incl. adapter to Q 30							190
	Q 40	<b>Side Table</b> Height adjustable side table, frames in black or white	46 46 47-77			695	751	839	

## Product description

### SHOWTIME

was specifically developed to meet the needs of agile work and communication settings. The mobile elements of the program support changing tasks and flexible use of space.

#### Roller Board

Mobile whiteboard, 15 mm thick, made of plywood with oiled edges. The whiteboard surface is made of glossy white HPL and writable on both sides. Thanks to two large wheels, it can be easily and quickly moved to any desired location and freely positioned in the room. The wheels are not lockable.

#### Flying Board

Portable, ultra light whiteboard with a thickness of 15 mm thick (weight: approx. 6.5 kg). The whiteboard surface is made of glossy white HPL and is writable on both sides. It can be used free standing in combination with the Woody stool, inserted vertically or horizontally into the presentation trolley, or simply leaned against the wall.

#### Magnetic Board

Portable whiteboard with a total thickness of 15 mm made of PET fleece, anthracite. Framed on the left and right by black-coated metal rails. A white, magnetic, writable surface is applied on both sides. The Magnetic Board can be used free standing with the Woody stool or inserted vertically or horizontally into the presentation trolley.

#### Silent Board

Portable whiteboard with a total thickness of 15 mm made of PET fleece, anthracite. Framed on the left and right by black-coated metal rails. The board is prepared for up to 12 Magnetic Dots onto which documents can be attached with magnets. The set has 3 dots in the colors: yellow (RAL 1023), red-orange (RAL 2001) and turquoise (RAL 6034). The Silent Board can be used free standing with the Woody stool or inserted vertically or horizontally into the presentation trolley.

#### Woody Stool

Made of 20 mm thick molded birch wood, finished in a natural lacquer or available in 7 other attractive stains. Its inclined seat promotes active sitting. The surface is coated with anti-slip lacquer. An optional felt pad (Soft Seat) made of PET fleece adds seating comfort. A handle hole makes it easy to move and stack. The multifunctional stool also serves as a holder for the ultra light Flying, Magnetic and Silent Boards.

#### Sets, customizable

The sets consist of stools and boards and the presentation set. The basis is always the Woody stool in natural birch, the birch stained version or a Soft Seat is available at additional cost. The different boards in the range (Flying Board, Magnetic Board or Silent Board) can be selected individually.

#### Side Table

Height adjustable side table (47- 77 cm) with cross-shaped base, available in white or black. Tabletop made of 15 mm birch plywood, size 460 x 460 mm, with rounded corners. The surface is finished in natural lacquer and 7 attractive stain shades or in the HPL white version. Handle hole in the top left corner of the tabletop.

#### Workstation

Transport trolley for up to 8 Flying, Silent or Magnetic Boards. Can also be used as a presentation trolley with 2 boards inserted vertically or horizontally. Top shelf in HPL white. Equipped with 4 universal double castors, Ø 75 mm, lockable.

# SLIDE









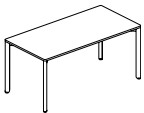
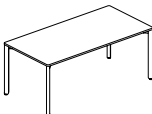
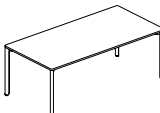
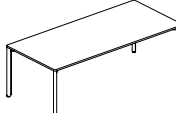
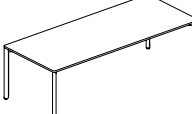
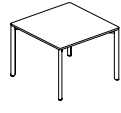
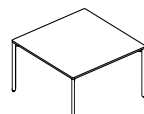

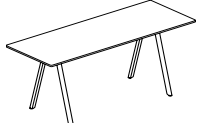
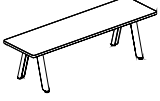
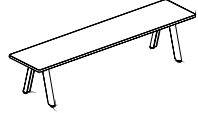

		Dim. in cm W D H	Oak urban grey  Oak matt Oak smoked Legs + frame, black, white, stone, pine, brick, mocca or RAL	Legs polished aluminium- frame moon	Oak solid oiled  Legs + frame, black, white, stone, pine, brick, mocca or RAL	Legs polished aluminium- frame moon	Laminate uni black, white, grey, stone, mocca  Legs + frame, black, white, stone, pine, brick, mocca or RAL	Legs polished aluminium frame moon	Laminate nano black, white, stone, pine, brick, mocca  Legs + frame, black, white, stone, pine, brick, mocca or RAL	Legs polished aluminium frame moon
D 10	<b>Table</b> Table legs, on glides or on castors.  straight edge bevelled edge edge profile	240 100 74	3.635 3.853	4.048 4.267	5.025	5.436	3.236 3.570	3.649 3.984	3.459 3.793	3.495 4.207
D 12	<b>Meeting table (two-part)</b> Table legs, on glides.  straight edge bevelled edge  <small>The 2 segments of the solid wood top fit together, but the solid wood slats are not in one line.</small>	320 120 74	5.838 6.120	6.264 6.548	7.927	8.354	5.010 5.445	5.437 5.871	5.366 5.800	5.793 6.227
D 23	<b>Meeting table</b> Table legs, on glides or on castors.  straight edge bevelled edge edge profile	190 110 74	3.442 3.642	3.867 4.068	4.670	5.096	3.096 3.401	3.521 3.827	3.290 3.595	3.715 4.021
D 25	<b>Meeting table</b> Table legs, on glides or on castors.  straight edge bevelled edge edge profile	240 110 74	3.830 4.060	4.266 4.496	5.294	5.729	3.585 3.816	3.834 4.188	3.642 3.998	4.079 4.433
D 27	<b>Meeting table</b> Table legs, on glides or on castors.  straight edge bevelled edge edge profile	200 148 74	4.201 4.443	4.717 4.960	5.696	6.216	3.738 4.110	4.255 4.629	4.013 4.384	4.529 4.903
D 29	<b>Meeting table</b> Table legs, on glides or on castors.  straight edge bevelled edge edge profile	240 148 74	4.667 4.940	5.247 5.515	6.333	6.911	4.132 4.547	4.709 5.124	4.461 4.876	5.038 5.453
D 32	<b>Meeting table</b> Table legs, on glides or on castors.  straight edge bevelled edge edge profile	Ø 110 74	2.279 2.338	2.690 2.750	3.020	3.433	2.043 2.138	2.456 2.550	2.155 2.251	2.568 2.662
D 34	<b>Meeting table</b> Table legs, on glides or on castors.  straight edge bevelled edge edge profile	Ø 140 74	3.189 3.290	3.602 3.703	4.266	4.677	2.794 2.945	3.206 3.360	2.976 3.127	3.387 3.542

		Dim. in cm W D H	Oak urban grey		Oak solid oiled		Laminate uni		Laminate nano	
			Oak matt Oak smoked							
			Legs + frame, black, white, stone, pine, brick, mocca or RAL	Legs polished aluminium- frame moon	Legs + frame, black, white, stone, pine, brick, mocca or RAL	Legs polished aluminium- frame moon	Legs + frame, black, white, stone, pine, brick, mocca or RAL	Legs polished aluminium- frame moon	Legs + frame, black, white, stone, pine, brick, mocca or RAL	Legs polished aluminium- frame moon
	<b>D 14</b> <b>Table</b> Table legs, on glides or on castors.  straight edge bevelled edge	160 80 74	2.739 2.916	3.151 3.327			2.479 2.734	2.891 3.147	2.598 2.853	3.010 3.266
	<b>D 16</b> <b>Table</b> Table legs, on glides or on castors.  straight edge bevelled edge	180 90 74	2.946 3.139	3.357 3.551			2.648 2.933	3.061 3.345	2.798 3.083	3.211 3.551
	<b>D 18</b> <b>Table</b> Table legs, on glides or on castors.  straight edge bevelled edge	200 100 74	3.133 3.344	3.546 3.757			2.797 3.113	3.210 3.524	2.983 3.298	3.396 3.710
	<b>D 20</b> <b>Table</b> Table legs, on glides or on castors.  straight edge bevelled edge	220 100 74	3.290 3.515	3.703 3.927			2.922 3.258	3.499 3.723	3.126 3.515	3.466 3.927
	<b>D 22</b> <b>Table</b> Table legs, on glides or on castors.  straight edge bevelled edge	240 100 74	3.443 3.682	3.855 4.096			3.046 3.399	3.457 3.812	3.268 3.622	3.680 4.034
	<b>D 36</b> <b>Meeting table</b> Table legs, on glides or on castors.  straight edge bevelled edge	100 100 74	2.529 2.678	2.941 3.090			2.321 2.535	2.732 2.947	2.414 2.628	2.825 3.040
	<b>D 38</b> <b>Meeting table</b> Table legs, on glides or on castors.  straight edge bevelled edge	155 155 74	3.418 3.567	3.832 3.979			2.958 3.177	3.371 3.589	3.181 3.400	3.594 3.811

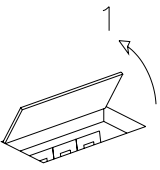
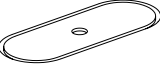
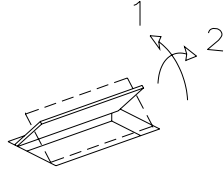
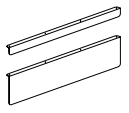
		Dim. in cm W D H	Oak urban grey  Oak matt Oak smoked Legs + frame, black, white, stone, pine, brick, mocca or RAL	Legs polished aluminium- frame moon	Oak solid oiled  Legs + frame, black, white, stone, pine, brick, mocca or RAL	Legs polished aluminium- frame moon	Laminate uni black, white, grey, stone, mocca  Legs + frame, black, white, stone, pine, brick, mocca or RAL	Legs polished aluminium- frame moon	Laminate nano black, white, stone, pine, brick, mocca  Legs + frame, black, white, stone, pine, brick, mocca or RAL	Legs polished aluminium- frame moon
	D 24 <b>Standing table</b> Table legs, on glides.  straight edge bevelled edge edge profile	180 90 110	3.226 3.400	3.637 3.811	4.210	4.621	2.929 3.193	3.341 3.606	3.079 3.344	3.491 3.757
	D 26  Table legs, on glides.  straight edge bevelled edge edge profile	200 90 110	3.394 3.582	3.807 3.995	4.467	4.879	3.066 3.353	3.479 3.765	3.233 3.520	3.646 3.932
	D 28 <b>Standing table</b> Table legs, on glides.  straight edge bevelled edge edge profile	220 90 110	3.565 3.765	3.977 4.178	4.725	5.137	3.207 3.511	3.621 3.923	3.390 3.694	3.804 4.107
	D 30 <b>Standing table</b> Table legs, on glides.  straight edge bevelled edge edge profile	240 90 110	3.693 3.905	4.106 4.319	4.940	5.352	3.303 3.629	3.717 4.043	3.503 3.829	3.917 4.243
	D 98 <b>Bench</b> Table legs, on glides.  straight edge bevelled edge	150 44 43	1.988 2.130	2.186 2.342			1.787 1.919	1.984 2.130	1.848 1.980	2.045 2.192
	D 99 <b>Bench</b> Table legs, on glides.  straight edge bevelled edge	190 44 43	2.265 2.428	2.462 2.640			2.004 2.154	2.202 2.366	2.082 2.232	2.280 2.444

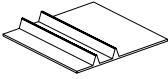
		Dim. in cm W D H					
	D 41	<b>Vertical cabling</b> Textile black, l = 200 cm, max. 5 cables for attachment to the table leg.	200	240			
	D 43	<b>Drawer below table top</b> With lock, steel black.  Cannot be combined with models D14 - D22 and D32 - D38.	50 26 5,5	556			
	OZ31 K000	<b>Cable outlet</b> Evoline Circle 80 Access, in black or white colour. 1 cable outlet with 2 openings, 1 clip for 6 single cables.		118			
	OZ31 K001	<b>Cable outlet + Qi-Charger</b> Evoline Circle 80 Access, in black or white colour. 1 cable outlet 1 rotating lid with a Qi charger 15W. Power cord Z90 required.		401			
	OZ31 SUU0	<b>Electric module</b> Evoline Circle 80, in black or white colour. 1 x power, 2 x USB charge (A/C), integrated cable outlet with cover. Connection cord l = 100 cm, with plug connection GST. Power cord Z90 required.	Ø 9	293			
	OZ31 SUU1	<b>Electric module + Qi Charger</b> Evoline Circle 80, in black or white colour. 1 Socket, 1 USB charge, (A/C), 1 rotating lid with a Qi charger 15W. Power cord Z90 required.		520			
	OZ90 0500	<b>Power cord 500 cm</b> Black cable, power plug with connection GST. To connect 1 electric module Z31 with a power socket.	500	53			
	OZ91 1005	<b>Distributor box power</b> 5 x outlet GST for up to 5 electrical modules Z31 per table. 1 input GST for power cord Z90. Total capacity in combination with 1 x powercord Z90 = max. 3500W.	32 28 3	75			

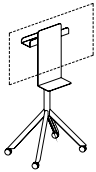
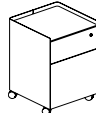
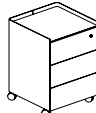
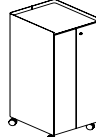
			Dim. in cm W D H					
	D 44	<b>Power box</b> The lid is finished to match the table top. The power strip is not included. It must be selected and completed from page 93. Standard positions of the power box see page 17.	23 11	898				
	D 44 M	For installation in the table center.		1.230				
	F 47	<b>Power box</b> The lid is finished in black, white, pine, brick or mocca. Can be used in the center of tables D12, D22 - D30. The power strip is not included. It must be selected and completed from page 93. Standard positions of the power box see page 17.	30 12	734				
	F 47 M	For installation in the table center.		1.071				
	D 49	<b>Power box(can be opened to 2 sides)</b> The lid is finished to match the table top. Can be used in the center of tables D12, D22 - D30. The power strip is not included. It must be selected and completed from page 93. Standard positions of the power box see page 17.	23 15	1.270				
	D 49 M	For installation in the table center.		1.597				
	D 50 D 51 D 52 D 53 D 54	<b>Modesty Panel</b> 7,5 or 30 cm high for table width 160 cm. for table width 180 cm. for table width 200 cm. for table width 220 cm. for table width 240 cm. Steel black, white, stone, pine, brick or mocca	136 7,5/30 156 7,5/30 176 7,5/30 196 7,5/30 216 7,5/30	378 404 428 452 474				
	D 56 D 57 D 58	<b>Acoustic Screen</b> Fiber core with fabric cover. Fiber core with fabric cover. Fiber core with fabric cover.  Base plate steel black.	66,5 39 76,5 39 13 39	512 528 548				
	D 95	<b>Divider insert</b> for container D 63, D 64, D 74 Felt anthracite	33 36	125				

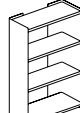
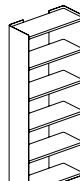
		Dim. in cm W D H		Oak urban grey  Oak matt Oak smoked	Solid oak look oiled	Laminate uni black white grey stone mocca	Laminate Nano black white stone pine brick mocca		
	D 60 <b>Media trolley</b> for flat screens up to approx. 55" diagonal (VESA 200 x 200 - 400 x 400, max. 18 kg). 1 tray for remote control, 1 tray for power strip, soundbar which can be attached. The power strip is not included. If required it can be selected and completed from page 93. Steel black, white, stone, pine, brick or mocca	77 59 155	2.208						
	D 63 <b>Mobile container</b> 1 drawer, 1 high drawer, with lock.  Container sides steel black, white, stone, pine, brick or mocca	43 43,5 60		1.852	1.852	1.765	1.799		
	D 64 <b>Mobile container</b> 3 drawers, with lock.  Container sides steel black, white, stone, pine, brick or mocca	43 43,5 60		2.049	2.049	1.950	1.984		
	D 74 <b>Mobile container</b> 2 doors, with lock. Behind doors is 1 drawer and 1 shelf.  Container sides steel black, white, stone, pine, brick or mocca	43 50 100		2.010	2.010	1.911	1.959		
	D 80 <b>Shelf unit (2H)</b> Shelves are fixed / not adjustable.  Unit sides steel black, white, stone, pine, brick or mocca	80 35 83		1.761	1.761	1.618	1.692		
	D 81 <b>Shelf unit (3H)</b> Shelves are fixed / not adjustable.  Unit sides steel black, white, stone, pine, brick or mocca	80 35 121		2.284	2.284	2.092	2.191		
	D 82 <b>Shelf unit (5H)</b> Shelves are fixed / not adjustable.  Unit sides steel black, white, stone, pine, brick or mocca	80 35 197		3.344	3.344	3.059	3.206		

## Product description

### SLIDE

Slide is a modular table system that offers a variety of tabletop shapes, sizes, edges and frames to suit nearly every application. Containers and shelves provide practical storage space in the workplace.

#### Tabletops

The veneer or laminate tabletops have an MDF core and are 23 mm thick. The edges are available in two different versions:

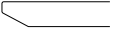
-  Straight edge
-  Beveled edge; a 10 mm thick edge with a lacquered chamfer on the underside

The underside of white-finished tabletops is white; all other versions have a black underside. Some tabletops are available in solid European oak with a thickness of 25 mm. Solid wood shows the character and history of the grown tree. Small knots, adhesions and irregularities in color and structure are natural features. The perimeter is tapered to a 10 mm vertical edge at the top and bottom.

-  Edge profile (solid oak)

Solid wood tabletops are protected by an oil/wax finish. We recommend an annual refresher treatment in accordance with our care instructions. The corners of the tabletops are rounded.

#### Table legs

Table legs are available in slanted (desk 20°, standing desk 15°) and straight version. They are either aluminium powder-coated in black, white, stone, pine, brick or mocca and have a fine surface texture. Or the legs are aluminium polished with a powder-coated frame in color „moon“. The groove in the U-shaped cross-section (28 x 20 mm) can be used to accommodate cables.

The table legs are connected by a steel frame, which is powder coated to match the legs. On the electrically height-adjustable table, the slanted legs attach directly to the lifting column.

#### Glides and castors

The table legs have adjustable glides to compensate for uneven floors. Many tables are also available with castors. Height-adjustable tables, standing desks and multi-part conference tables are not available with castors.

#### Desk drawer

The lockable drawer made of steel, black powder-coated, can be assembled afterwards. With full extension, without divider insert.

#### Electrically height-adjustable desks

The electrically adjustable desks can be set to heights between 74 and 114 cm. The control switch is located under the tabletop. As a safety precaution, the height adjustment is programmed to stop 50 mm before the downward limit. The final reduced-speed adjustment is activated by pressing the button again.

The standard cable net cannot be used in combination with a flush-mounted lid. This is also omitted when using a modesty panel. For the electrically height-adjustable tables, we recommend using a 7.5 cm high modesty panel (risk of collision), which at the same time conceal the previously described under-table fixtures. The power cable has an available length of 4 m.

#### Modesty panels

Modesty panels are available in two heights (7.5 cm and 30 cm) in powder-coated steel to match the color of the table frame. The modesty panels are attached under the table. The 7.5-cm modesty panels can be used to conceal technical fixtures.

#### Acoustic screens

Tables can be divided using acoustic screens. The noise-reducing panels are available in a variety of fabrics. The feet are made of black powder-coated steel and are fitted with felt glides. All acoustic screens can be combined at right angles with no gap.

#### Mobile containers on castors

The outside panels and backs of the mobile containers are made of steel, finely powder coated to match the table legs.

Drawers are push-to-open, with partial extension and self-closing mechanisms. All containers are delivered with a lock. The cylinder is located at the upper-right front of the drawer unit. Fronts and tops are available to match the tabletops.

To accompany solid oak tabletops, containers are finished with solid oak-look veneer.

#### Shelf units

The side panels of the shelf units are of finely structured powder-coated steel, available in colors to match the table legs. The shelves can be chosen to coordinate with tabletop surfaces. Shelves are available with solid oak-look veneer for use with solid oak tabletops.

Veneer and laminate shelves have a thickness of 29 mm. The shelf unit is delivered disassembled. Shelf height cannot be adjusted and is designed to accommodate lever arch files.

Shelves must be anchored to the wall to secure against tipping.

#### Electric supply and cable routing for tables

The vertical cable routing runs through flexible cable covers in the groove of the table leg. Horizontal cables are fixed under the tabletop using cable sheaths with Velcro closures. On the electrically height-adjustable table there is a cable net under the tabletop.

Single or multiple electric outlets, available in black or white, can be installed in the specified positions of the table surface.

In the case of multiple outlets, a pluggable power distribution box is required, one per circuit.

#### Power box (opens to one side)

The power box for desks (D44) is mounted flush into the tabletop. The flip-open lid is finished to match the tabletop. A 17-mm cutout serves as a cable outlet and provides access to the power strip below. Power strips must be ordered separately. Power strips with various configurations must be selected and completed from page 93 on.

#### Power box (oval)

The power box (D47) is mounted flush into the tabletop. It is usually powder-coated in the same color as the table frames, but an aluminum polished version is not available. The lid is held in position by several magnets for better handling and to allow the flexible rearrangement of the tabletops. Cables can be led out through the all-round gap to all sides. Power strips must be selected and ordered separately. Power strips with various configurations must be selected and completed from page 93 on.

#### Power box (opens to two sides)

The power box for conference tables (D49) is mounted flush into the tabletop. The flip-open lid is finished to match the tabletop. The lid can be opened to two sides. A 17-mm cutout on each side serves as a cable outlet and provides access to the power strip below. Power strips must be ordered separately. Power strips with various configurations must be selected and completed from page 93 on.

#### Media element

The media element is fitted with castors and suitable for screens up to 55 inches (diagonal) and approx. 25 kg. The attachments can be adjusted to accommodate VESA 200 x 200 to VESA 400 x 400.

Screen height is selected during set-up and adjusted in 5-cm steps up to about 30 cm. The front of the unit provides space for a soundbar.

Cable routing runs through the central column. A power strip can be placed in the tray.

D01...D09 / D02...D10  
D14...D22 / D24...D30

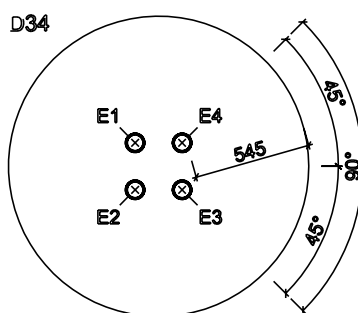
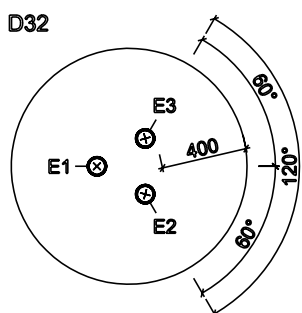
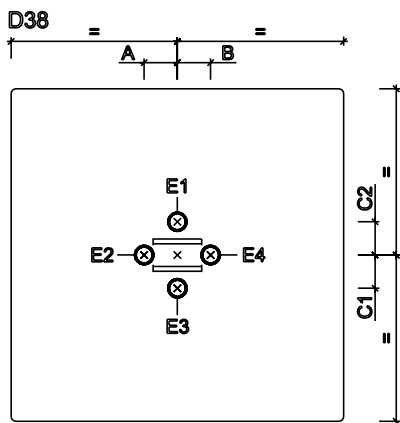
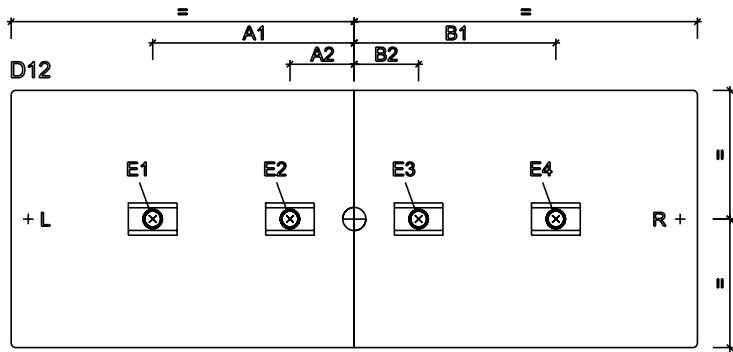
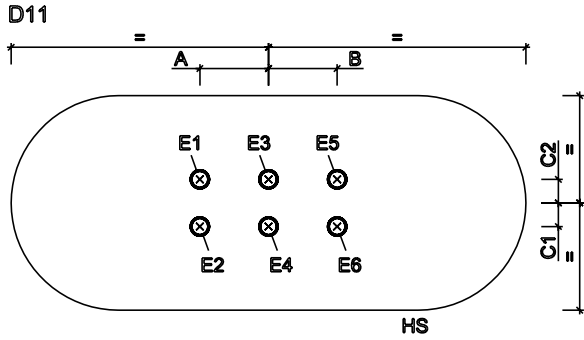
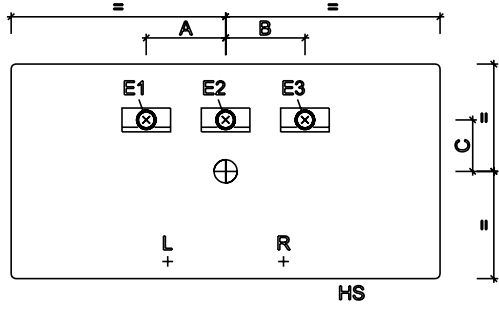

Mod. / Pos.:	E1	E2	E3
D01, D03, D05	A= 370 / C= 240	0 / C= 240	B= 370 / C= 240
D07, D09	A= 470 / C= 240	0 / C= 240	B= 470 / C= 240

D02	A= 320 / C= 240	0 / C= 240	B= 320 / C= 240
D04	A= 370 / C= 240	0 / C= 240	B= 370 / C= 240
D06	A= 420 / C= 240	0 / C= 240	B= 420 / C= 240
D08	A= 470 / C= 240	0 / C= 240	B= 470 / C= 240
D10	A= 520 / C= 240	0 / C= 240	B= 520 / C= 240

D14	A= 320 / C= 140	0 / C= 140	B= 320 / C= 140
D16	A= 420 / C= 190	0 / C= 190	B= 420 / C= 190
D18	A= 520 / C= 240	0 / C= 240	B= 520 / C= 240
D20	A= 620 / C= 240	0 / C= 240	B= 620 / C= 240
D22	A= 720 / C= 240	0 / C= 240	B= 720 / C= 240

D24	A= 370 / 0	0 / 0	B= 370 / 0
D26	A= 420 / 0	0 / 0	B= 420 / 0
D28	A= 470 / 0	0 / 0	B= 470 / 0
D30	A= 520 / 0	0 / 0	B= 520 / 0

Mod. / Pos.:	E1 / E2	E3 / E4	E5 / E6
D11	A= 320 / C1,2= 110	0 / C1,2= 110	B= 320 / C1,2= 110





Mod. / Pos.:	E1 / E4	E2 / E3
D12	A1,B1= 940	A2,B2= 300

Mod. / Pos.:	E1 / E2 / E3 / E4
D38	A, B, C = 155

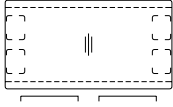

# SLIDE CONNECT



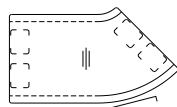

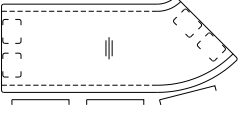
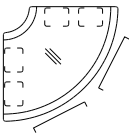
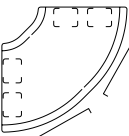
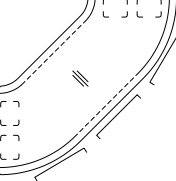
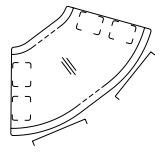
		Dim. in cm W D H	Oak urban grey Oak matt Oak smoked	Laminate uni black white grey stone mocca Further finishes on request.	Laminate nano black white stone pine brick mocca	
* Table segment not to use as single table						
	<b>F0 JG</b>	<b>Rectangle</b>	160 85 74/110			
		straight edge bevelled edge		1.760 1.888	1.435 1.568	1.676 1.827
	<b>F0 B1 J</b>	<b>Modesty Panel</b> steel, black incl. horizontal cable routing	10			537
	<b>F0 B2 J</b>	<b>Modesty Panel</b> steel, black incl. horizontal cable routing	30			599
	<b>F0 PG</b>	<b>Rectangle</b>	220 85 74/110			
		straight edge bevelled edge		2.153 2.329	1.705 1.890	2.039 2.246
	<b>F0 B1 P</b>	<b>Modesty Panel</b> steel, black incl. horizontal cable routing	10			650
	<b>F0 B2 P</b>	<b>Modesty Panel</b> steel, black incl. horizontal cable routing	30			735
	<b>F1 MG</b>	<b>End top</b>	190 85 74/110			
		straight edge bevelled edge		1.957 2.109	1.571 1.729	1.859 2.036
	<b>F1 B1 M</b>	<b>Modesty Panel</b> steel, black incl. horizontal cable routing	10			528
	<b>F1 B2 M</b>	<b>Modesty Panel</b> steel, black incl. horizontal cable routing	30			586
	<b>F1 SG</b>	<b>End top</b>	250 85 74/110			
		straight edge bevelled edge		2.350 2.550	1.842 2.051	2.220 2.454
	<b>F1 B1 S</b>	<b>Modesty Panel</b> steel, black incl. horizontal cable routing	10			641
	<b>F1 B2 S</b>	<b>Modesty Panel</b> steel, black incl. horizontal cable routing	30			724
	<b>F2 KG*</b>	<b>Corner top</b>	170 85 74/110			
		straight edge bevelled edge		1.826 1.963	1.480 1.622	1.737 1.897
	<b>F2 B1 K</b>	<b>Modesty Panel</b> steel, black incl. horizontal cable routing	10			637
	<b>F2 B2 K</b>	<b>Modesty Panel</b> steel, black incl. horizontal cable routing	30			732

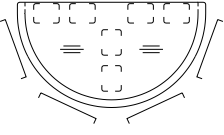
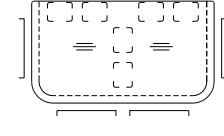
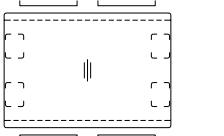
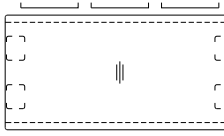
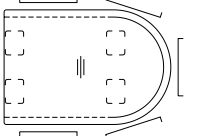
		Dim. in cm W D H	Oak urban grey Oak matt Oak smoked	Laminate uni black white grey stone mocca  Further finishes on request.	Laminate nano black white stone pine brick mocca	
* Table segment not to use as single table						
	<b>F2 QG*</b>	<b>Corner top</b>	230 85 74/110			
		straight edge bevelled edge		2.220 2.403	1.752 1.945	2.099 2.315
	<b>F2 B1 Q</b>	<b>Modesty Panel</b> steel, black incl. horizontal cable routing	10			750
	<b>F2 B2 Q</b>	<b>Modesty Panel</b> steel, black incl. horizontal cable routing	30			867
	<b>F3 JG*</b>	<b>Head top 90°</b>	160 85 74/110			
		straight edge bevelled edge		1.760 1.888	1.435 1.568	1.676 1.827
	<b>F3 B1 J</b>	<b>Modesty Panel</b> steel, black incl. horizontal cable routing	10			718
	<b>F3 B2 J</b>	<b>Modesty Panel</b> steel, black incl. horizontal cable routing	30			818
	<b>F3 KG*</b>	<b>Head top 90°</b>	170 85 74/110			
		straight edge bevelled edge		1.826 1.963	1.480 1.622	1.737 1.897
	<b>F3 B1 K</b>	<b>Modesty Panel</b> steel, black incl. horizontal cable routing	10			738
	<b>F3 B2 K</b>	<b>Modesty Panel</b> steel, black incl. horizontal cable routing	30			840
	<b>F3 RG*</b>	<b>Head top 90°</b>	240 85 74/110			
		straight edge bevelled edge		2.285 2.476	1.797 1.998	2.161 2.385
	<b>F3 B1 R</b>	<b>Modesty Panel</b> steel, black incl. horizontal cable routing	10			870
	<b>F3 B2 R</b>	<b>Modesty Panel</b> steel, black incl. horizontal cable routing	30			1.000
	<b>F4 KG*</b>	<b>Head top 75°</b>	170 85 74/110			
		straight edge bevelled edge		1.826 1.963	1.480 1.622	1.737 1.897
	<b>F4 B1 K</b>	<b>Modesty Panel</b> steel, black incl. horizontal cable routing	10			816
	<b>F4 B2 K</b>	<b>Modesty Panel</b> steel, black incl. horizontal cable routing	30			951

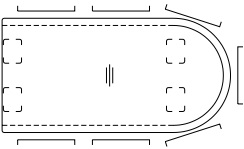
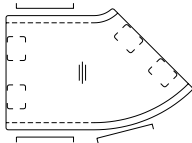
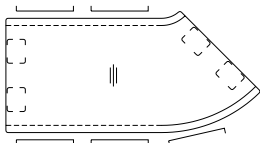
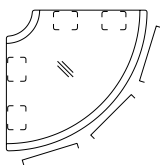
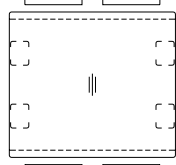
		Dim. in cm W D H	Oak urban grey Oak matt Oak smoked	Laminate uni black white grey stone mocca  Further finishes on request.	Laminate nano black white stone pine brick mocca
* Table segment not to use as single table					
<b>F8 KI</b> 	<b>End top</b>	170 95 74/110			
	straight edge bevelled edge		2.182 2.318	1.837 1.978	2.094 2.253
<b>F9 KI</b> 	<b>End top</b>	170 95 74/110			
	straight edge bevelled edge		2.182 2.318	1.837 1.978	2.094 2.253
<b>F0 JL</b> 	<b>Rectangle</b>	160 110 74/110			
	straight edge bevelled edge		2.399 2.649	1.916 2.169	2.123 2.373
<b>F0 PL</b> 	<b>Rectangle</b>	220 110 74/110			
	straight edge bevelled edge		3.032 3.375	2.367 2.714	2.652 2.997
<b>F1 JL</b> 	<b>End top</b>	160 110 74/110			
	straight edge bevelled edge		2.399 2.649	1.916 2.169	2.123 2.373

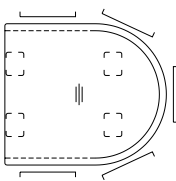
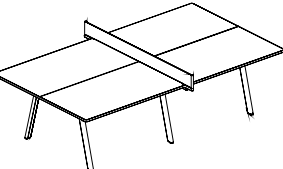
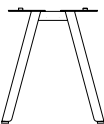
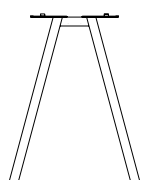
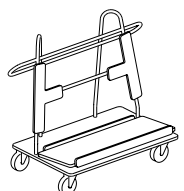
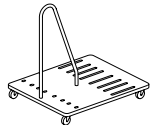
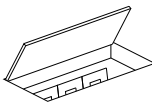
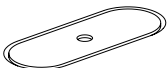
		Dim. in cm W D H	Oak urban grey Oak matt Oak smoked	Laminate uni black white grey stone mocca Further finishes on request.	Laminate nano black white stone pine brick mocca	
* Table segment not to use as single table						
<b>F1 PL</b> 	<b>End top</b>	220 110 74/110				
	straight edge		3.032	2.367	2.652	
	bevelled edge		3.375	2.714	2.997	
<b>F2 LL*</b> 	<b>Corner top</b>	180 110 74/110				
	straight edge		2.609	2.066	2.300	
	bevelled edge		2.892	2.350	2.582	
<b>F2 PL*</b> 	<b>Corner top</b>	220 110 74/110				
	straight edge		3.032	2.367	2.652	
	bevelled edge		3.375	2.714	2.997	
<b>F3 NL*</b> 	<b>Corner top</b>	200 110 74/110				
	straight edge		2.820	2.217	2.476	
	bevelled edge		3.133	2.533	2.790	
<b>F0 JT</b> 	<b>Rectangle meeting table</b>	160 150 74				
	straight edge		2.817	2.274	2.546	
	bevelled edge		3.070	2.530	2.800	

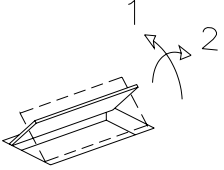
		Dim. in cm W D H	Oak urban grey Oak matt Oak smoked	Laminate uni black white grey stone mocca  Further finishes on request.	Laminate nano black white stone pine brick mocca
* Table segment not to use as single table					
	<b>F1 JT</b> <b>End top meeting table</b>  straight edge bevelled edge	160 150 74	2.817 3.070	2.274 2.530	2.546 2.800
	<b>OF 66</b> <b>Table tennis table</b> Consisting of 2 table tops and 3 table legs, without net, straight edge  Black, white, stone, pine, brick, mocca or RAL Solid oak, natural lacquer finish Polished aluminum	247 152,5 74			6.734 6.933 7.124
	<b>F 70</b> <b>Table leg, in 3 depths</b> Depths 1 (85) 2 (110) 3 (150)  Black, white, stone, pine, brick, mocca or RAL Solid oak, natural lacquer finish Polished aluminum	74	703 767 837		
	<b>F 80</b> <b>Table leg, in 2 depths</b> Depths 1 (85) 2 (110)  Black, white, stone, pine, brick, mocca or RAL Solid oak, natural lacquer finish Polished aluminum	110	758 853 924		
	<b>F 84</b> <b>Transport trolley for tabletops</b> for max. 6 tabletops and cable conduits. With safety belt.	145 82 122 Dimensions without equipment	1.847		
	<b>F 85</b> <b>Transport trolley for table legs</b> for max. 4 table legs	100 79 96	810		
	<b>D 44</b> <b>Power box</b> The lid is finished to match the table top. The power strip is not included. It must be selected and completed from page 93. Standard positions of the power box see page 27.	23 11	899		
	<b>F 47</b> <b>Power box</b> The lid is finished in black, white, stone, pine, brick or mocca. The power strip is not included. It must be selected and completed from page 93. Standard positions of the power box see p. 27. Special items on request.	30 12	734		

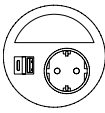
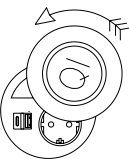
		Dim. in cm W D H			
	<b>D 49</b> <b>Power box (can be opened to 2 sides)</b> The lid is finished to match the table top. The power strip is not included. It must be selected and completed from page 93. Standard positions of the power box see page 27.	23 15	1.270		
	<b>F 41</b> <b>Vertical cabling</b> Textile black, l = 200 cm, max. 5 cables for attachment to the table leg.		240		
	<b>V 81</b> <b>Horizontal cabling</b> Textile. For attachment below tabletop.		146		
	<b>OZ31 K000</b> <b>Cable outlet</b> Evoline Circle 80 Access, in black or white colour. 1 cable outlet with 2 openings, 1 clip for 6 single cables.	Ø 9,2	118		
	<b>OZ31 K001</b> <b>Cable outlet + Qi-Charger</b> Evoline Circle 80 Access, in black or white colour. 1 cable outlet 1 rotating lid with a Qi charger 15W. Power cord Z90 required.	Ø 9,2	401		
	<b>OZ31 SUU0</b> <b>Electric module</b> Evoline Circle 80, in black or white colour. 1 x power, 2 x USB charge (A/C), integrated cable outlet with cover. Connection cord l = 100 cm, with plug connection GST. Power cord Z90 required.	Ø 9,2	293		
	<b>OZ31 SUU1</b> <b>Electric module + Qi Charger</b> Evoline Circle 80, in black or white colour. 1 Socket, 1 USB charge, (A/C), 1 rotating lid with a Qi charger 15W. Power cord Z90 required.	Ø 9,2	520		
	<b>OZ90 0500</b> <b>Power cord 500 cm</b> Black cable, power plug with connection GST. To connect 1 electric module Z31 with a power socket.	500	53		
	<b>OZ91 1005</b> <b>Distributor box power</b> 5 x outlet GST for up to 5 electrical modules Z31 per table. 1 input GST for power cord Z90. Total capacity in combination with 1 x powercord Z90 = max. 3500W.	32 28 3	75		

## Product description

### SLIDE Connect

is an intelligent, modular table system for the planning and realization of fixed or flexible tables and conference systems. The modular system of tabletops consists of many shapes and dimensions and table legs in sitting height (74cm) and in standing height (110cm). It allows maximum flexibility and usability. Challenges when planning work, meeting, and conference rooms can be answered using one uniform design language.

The A-shaped table frames appear visually light while offering high stability in any table height and table depths from 85 to 150 cm. Tabletops and table frames are connected without the need of tools by an easy-to-use mechanism. Table frames are either put underneath one single table top or connecting two table tops with each other. For assembly, a table base is fixed to the table top via two locks. When linked together, the table base establishes a firm table connection connecting two table tops via four locks.

### Tabletops

The tabletops are MDF material. The top's thickness is approx. 30 mm, depending on top and bottom layers. The longitudinal edges of the tabletops are available with straight or chamfered edge.



Straight edge



Beveled edge; a 13 mm thick edge with a lacquered chamfer on the underside

For technical reasons, transverse edges, where table frames are placed, are always straight. The selected profile for the longitudinal edge also continues over the transverse end panel sides. All tabletop corners are rounded with a radius of 21 mm.

Further tabletop sizes and shapes as well as non-standard wood types and surfaces are available upon request. Tabletops are scalable in length and width according to the customer's requirements. In addition to our standard dimensions specified in the price list, we provide intermediate dimensions centimeter accurate.

### FENIX<sup>NTM</sup>

Fenix NTM is a nanotech material from the company Arpa Industriale, which we label Laminate Nano in our collection.

Laminate grey is a durable standard laminate from the company Thermopal (U 009 ST 47).

### Table legs

SLIDE Connect tables have table frames with slanted legs (15°). The table legs are made of aluminum and have a U-shaped cross-section. They are available in 2 table heights (74 and 110 cm) and in 3 depths, see Fig. p.27.

The table legs are available in black, white, stone, pine, brick or mocca color with a fine structure powder coating or in aluminum polished. Other colors are available on request. Crosspiece between table legs and adapter plates are always black.

The groove on the inner table leg has a dimension of 28 x 20 mm and can accommodate cables. The table legs have adjustable glides that can compensate for irregularities in the floor.

### Modesty panels with integrated cabling

The modesty panels are fixed under the tabletop by knurled screws without the need of tools. They are mounted on the front side. Modesty panels in black powder-coated steel are available in 2 heights (10 cm and 30 cm).

The gap between the panel and the tabletop (12 mm wide) allows cabling at almost any point between the cable routing behind the panel from behind the modesty panel onto the tabletop.

### Horizontal cable routing

Horizontal cable routing comes as standard with stable velcro straps, which can be used to securely hold and variably organize cable bundles on the back of the modesty panels.

### Vertical cable element

The vertical cable routing runs through a flexible cable cover in the groove of the table leg. The textile cable cover is held in place via a velcro strip.

### Power box (oval)

The power box (F 47) is integrated flush with the tabletop. The lid, rounded on both sides, is provided with a grip hole. They are available in the same colors as the table legs. A polished aluminum version is not available.

The removable lid remains safely in place by several magnets during handling and transport of the tabletops. Cables can be lead through a surrounding gap to all sides. Power strips with various configurations must be selected and completed from page 93 on.

### Power box (opens to one side)

The power box for desks (D44) is mounted flush into the tabletop. The flip-open lid is finished to match the tabletop. A 17-mm cutout serves as a cable outlet and provides access to the power strip below. Power strips must be ordered separately. Power strips with various configurations must be selected and completed from page 93 on.

### Power box (opens to two sides)

The power box for conference tables (D49) is mounted flush into the tabletop. The flip-open lid is finished to match the tabletop. The lid can be opened to two sides. A 17-mm cutout on each side serves as a cable outlet and provides access to the power strip below. Power strips must be ordered separately. Power strips with various configurations must be selected and completed from page 93 on.

**FO JG Rectangle**  
**F 47 Power box**

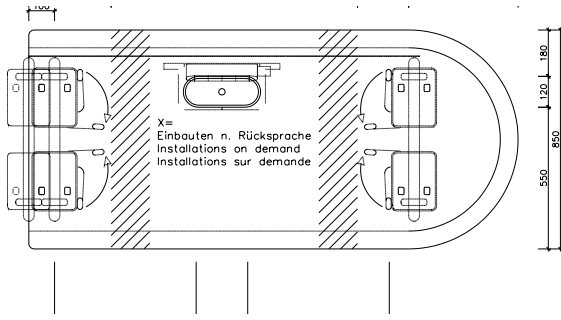

**Lateral cut**

OF...B1... + B2...

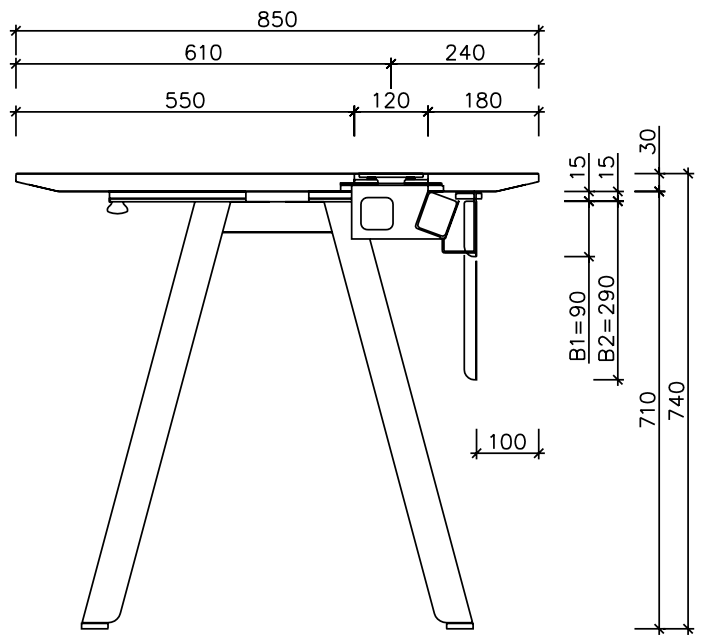

**F1 JL End top**  
**F 47 Power box**

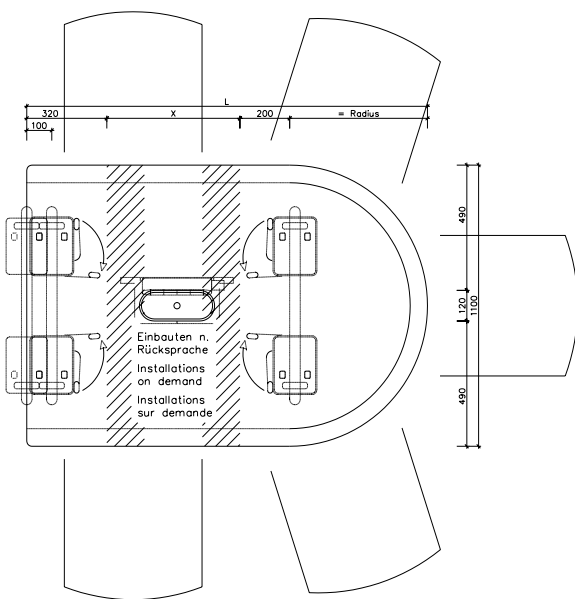

**Various table depths and frame variants**

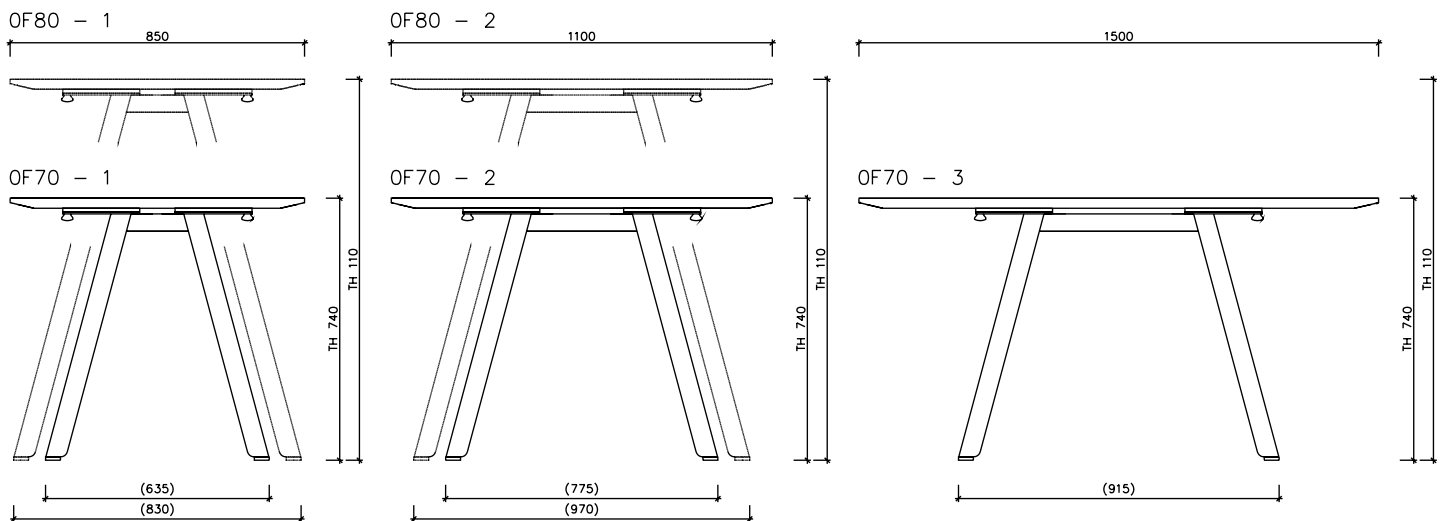

Prices of example units

Scale 1:100

A

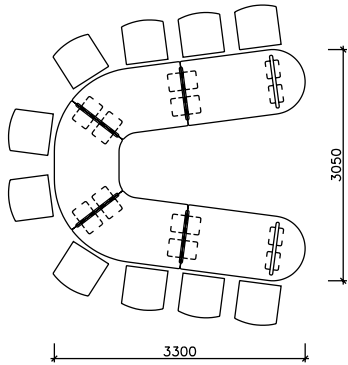

Sitting height Euro 12.934 \*  
 Standing height Euro 13.270 \*

B

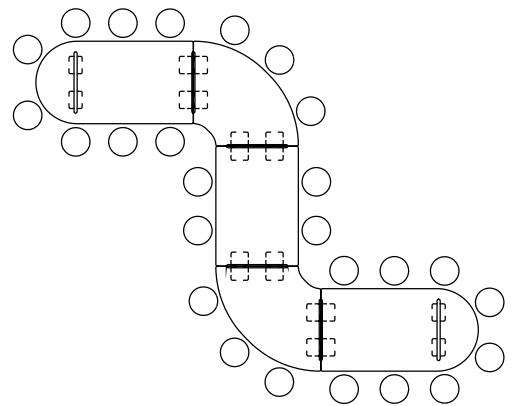

Sitting height Euro 18.008 \*  
 Standing height Euro 18.345 \*

C

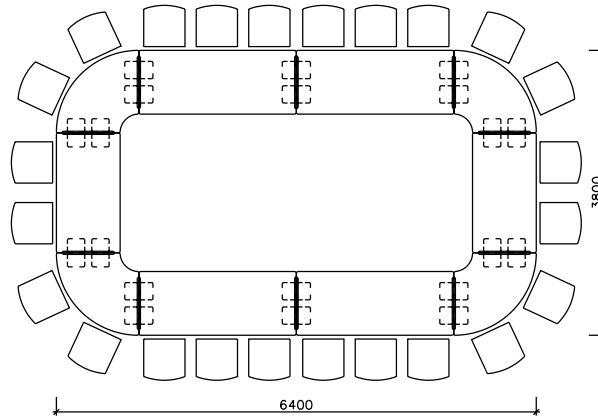

Sitting height Euro 25.748 \*

D

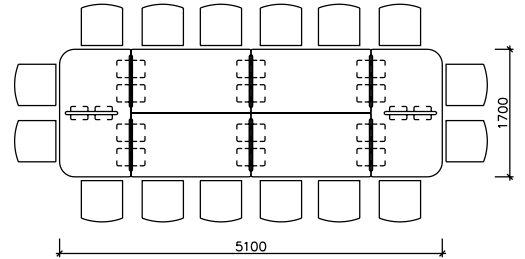

Sitting height Euro 16.291 \*

E

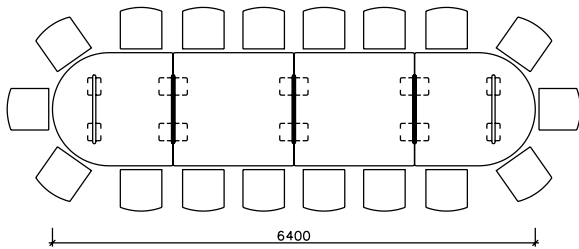

Sitting height Euro 14.769 \*

F

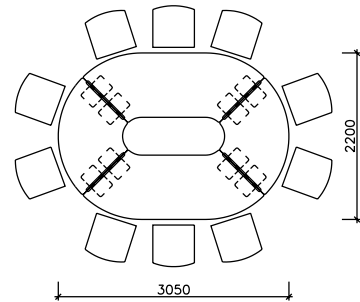





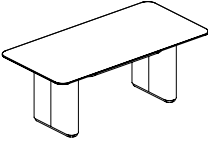
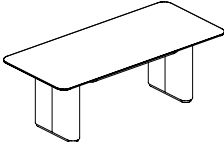
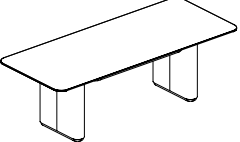
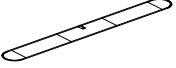
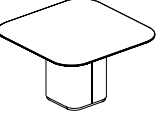
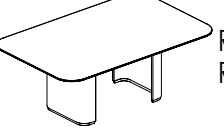

Sitting height Euro 10.782 \*

\* Retail prices in Euro. Wood finish oak urban grey/oak matt/oak smoked.

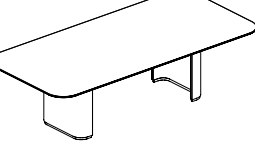
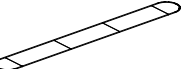
# Spark

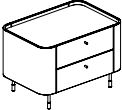
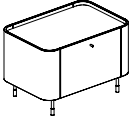
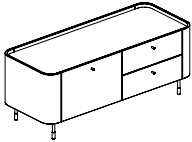
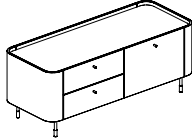

		Dim. in cm W D H	Oak grey titan urban grey  Oak matt Oak smoked Cherry Walnut	Walnut tobacco	Laminate nano black white stone pine brick mocca		
	X 07 <b>Desk</b> Electrically height-adjustable from 74 - 120 cm. Incl. cable guide and anthracite cable tray. Side panels black, white, stone, pine, brick, mocca lacquered. Frame in gold, bronze, silver or anthracite  Straight edge Chamfered edge	200 100	6.829 6.964	7.581 7.730	6.806 7.120		
	X 09 <b>Desk</b> Electrically height-adjustable from 74 - 120 cm. Incl. cable guide and anthracite cable tray. Side panels black, white, stone, pine, brick, mocca lacquered. Frame in gold, bronze, silver or anthracite  Straight edge Chamfered edge	220 100	6.925 7.068	7.755 7.916	6.898 7.230		
	X 11 <b>Desk</b> Electrically height-adjustable from 74 - 120 cm. Incl. cable guide and anthracite cable tray. Side panels black, white, stone, pine, brick, mocca lacquered. Frame in gold, bronze, silver or anthracite  Straight edge Chamfered edge	240 100	7.026 7.178	7.939 8.111	6.989 7.341		
	X 91 <b>Built-in desk unit</b> for desks, in black, white, stone, pine, brick or mocca. The power strip is not included. It must be selected and completed from page 93.	118,5 14,5				1.442	
	X 13 <b>Meeting table</b> Frame in black, white, stone, pine, brick, mocca lacquered. Base in gold, bronze, silver or anthracite  Straight edge Chamfered edge	125 125 74	3.766 3.877	4.255 4.381	3.582 3.842		
	X 23 <b>Meeting table</b> Frame in black, white, stone, pine, brick, mocca lacquered. Base in gold, bronze, silver or anthracite  Straight edge Chamfered edge	200 125 74	5.284 5.443	6.102 6.286	5.039 5.398		
	X 92 <b>Built-in desk unit</b> for meeting tables, in black, white, stone, pine, brick, or mocha. The power strip is not included. It must be selected and completed from page 93.	94,5 18,5				1.309	
	X 33 <b>Meeting table</b> Frame in black, white, stone, pine, brick, mocca lacquered. Base in gold, bronze, silver or anthracite  Straight edge Chamfered edge	270 125 74	5.716 5.899	6.745 6.960	5.372 5.780		
	X 93 <b>Built-in desk unit</b> for meeting tables, in black, white, stone, pine, brick, or mocha. The power strip is not included. It must be selected and completed from page 93.	148,9 18,5				1.649	

		Dim. in cm W D H	Cover panels + Fronts		Cover panel: Laminate nano Fronts: Lacquered			
			Oak grey titan urban grey  Oak matt Oak smoked Cherry Walnut	Walnut tobacco				black white stone pine brick mocca
	X 63	<b>Sideboard</b> Side panels in black, white, stone, pine, brick, mocca lacquered. Frame in gold, bronze, silver or anthracite. 2 drawers with central locking in front	82 56 55	3.117 3.216	3.802 3.902	3.288 3.387		
	X 64	<b>Sideboard</b> Side panels in black, white, stone, pine, brick, mocca lacquered. Frame in gold, bronze, silver or anthracite. 1 file drawer with central locking in front	82 56 55	2.875 2.975	3.508 3.607	3.034 3.133		
	X 70	<b>Sideboard</b> Side panels in black, white, stone, pine, brick, mocca lacquered. Frame in gold, bronze, silver or anthracite. 1 file drawer, 2 drawers with central locking in front	140 56 55	4.176 4.376	5.011 5.210	4.364 4.563		
	X 71	<b>Sideboard</b> Side panels in black, white, stone, pine, brick, mocca lacquered. Frame in gold, bronze, silver or anthracite. 2 drawers, 1 file drawer with central locking in front	140 56 55	4.176 4.376	5.011 5.210	4.364 4.563		
	R 40	<b>Leather desk pad</b> Black leather  ... customer-supplied leather Required leather: 96 cm x 70 cm	85 55 0,4				747 618	
	R 42	<b>Cable outlet</b> Chrome, matt chrome or black. Standard positions see p. 34. Special items on request.	9 9				125	
	X 80	<b>Vertical cabling</b> Lacquered in the same colour as the side panel. To attach to the inner side of panel.					202	



## Product description

### SPARK

is a management furniture program featuring electric height-adjustable desks and fixed-height tables. Rectangular tabletops rest on a frame with two panel legs. Sideboards with drawers offer additional storage space.

#### Tabletops

The veneered tabletops are made of MDF. For height-adjustable desks, the tabletop thickness is 26 mm; for fixed-height conference tables, it is 31 mm. Edges are available either straight or profiled. A 13 mm thick solid veneer edge transitions into a chamfered edge sloping inward at a 13° angle. Tabletop corners are rounded: 100 mm corner radius for height-adjustable desks and 200 mm for fixed-height meeting tables. The chamfer and the underside of the tabletops are lacquered in anthracite. The veneer runs lengthwise. Custom-sized tabletops are available upon request. The cable tray underneath the tabletop is made of felt in anthracite color.

#### Frame height-adjustable

The frame of the height-adjustable desks can be electrically adjusted in height from 74 to 120 cm. The table legs are made of molded wood, rounded in a semi-circular shape at each end. They are available in lacquer finishes as per Price List Column 3. Special colors are available upon request. The desk can be leveled using adjustable glides integrated into the legs. The lifting column is covered with an aluminum profile, which also houses the cable guide duct. The aluminum tube is available with a coating in gold, silver, bronze, or anthracite. The panel leg base is coated in the same color.

#### Frame with a set height

The frame for fixed-height meeting tables provides a table height of 74 cm. The frame sides are C-shaped and open inward. The optional cable routing runs inside the panel leg behind a cover, lacquered in the same color. Panel legs are available in finishes listed in Price List Column 3; special colors are available upon request. The table can be leveled using adjustable glides in the legs. Bases are available in gold, silver, bronze, or anthracite.

#### Built-in desk unit

An optional table inset module is available for both height adjustable desks and fixed height meeting tables. Available in two different built-in lengths, made of metal in black, white, stone, pine, brick or mocca finish. Underneath the built-in panel (X 91), the desks have a utensil tray, 1 empty space for individual cabling and one tray pre-configured for a power strip (not included). By arranging the 3 insert elements, the customer can individually determine whether the cable outlet should be on the left, right or in the middle. The utensil tray and cable tray can be installed underneath in the same way.

On the meeting tables underneath the build-in unit (X 92/X 93) there is space for individual cabling and 1 tray with preparation for an electrical strip (not included).

Power strips with various configurations must be selected and completed from page 93 on.

### Sideboards

The sideboards with drawers are available in various dimensions, with outer sides and rear panel lacquered according to Price List Column 3. Fronts and top panels are veneered either crosswise or vertically. All sideboards are available with locking mechanism. The lock cylinder is positioned on the front right of the cover panel. Handles and legs are available in gold, silver, bronze, or anthracite.

#### Power box (can be opened to 1 side)

The power box (D 44) is leveled into the tabletop and finished to match the tabletop. A 17 mm wide cut-out serves as cable outlet. The power box does not yet contain a power strip. Power strips with various configurations must be selected and completed from page 93 on.

#### Electrical Box (oval)

The electrical box (F 47) is flush-mounted into the tabletop. It is available in the same color as the table frames. The lid is held in place with magnets. Cables can exit on all sides through the surrounding gap. A power strip must be selected and ordered separately. Power strips with different configurations are available from page 93 on.

#### Power box (can be opened to 2 sides)

The power box (D 49) is leveled into the tabletop and finished to match the tabletop. A 17 mm wide cut-out each serves as cable outlet. The power box does not yet contain a power strip. Power strips with various configurations must be selected and completed from page 93 on.

**Meeting table X13**  
 Integrated desk modules F47 / D49  
 (centered L/C) possible

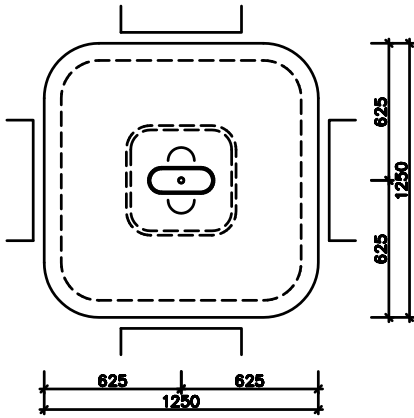

**Desks X07 / X09 / X11**  
 with X91 integrated desk module

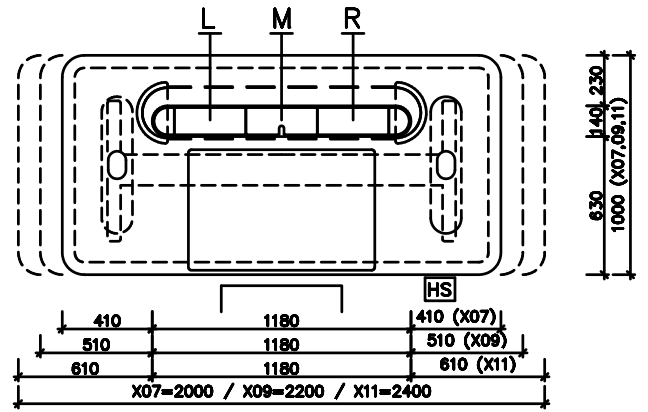

**Meeting table X23 with X92 integrated desk module**  
 (alt. R42 / D44 / F47 / D49 possible)

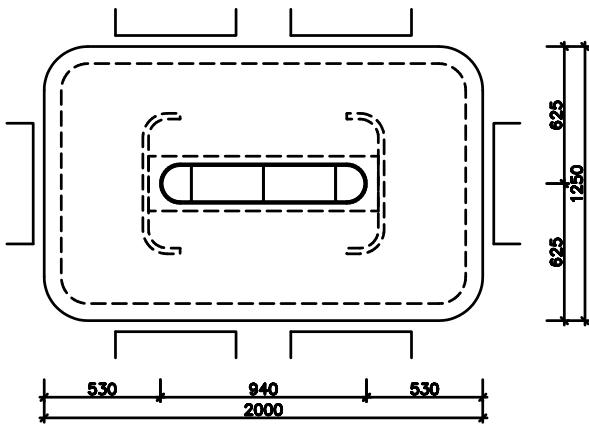

**X91 integrated desk module (only for desks)**

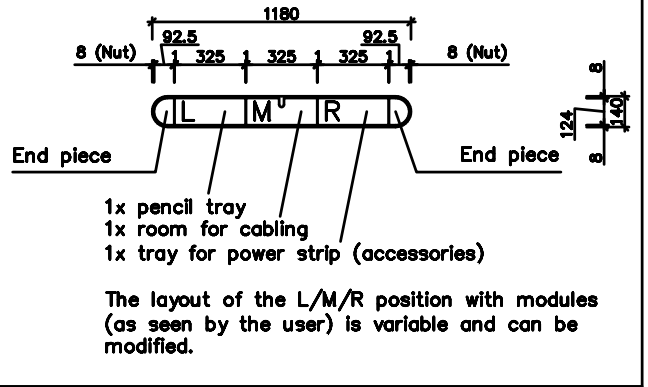

**Desks X07 / X09 / X11**  
 with accessories F47 / R42 / D44

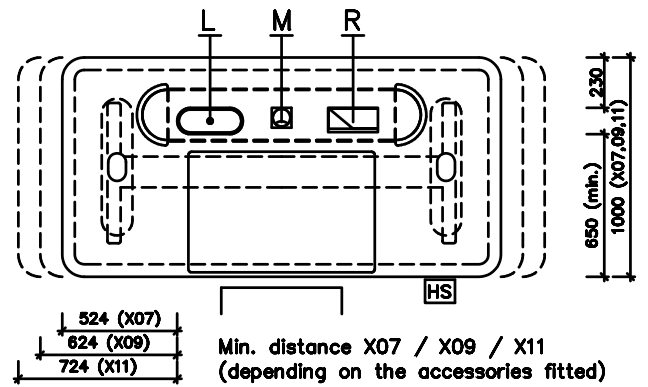

**Meeting table X33 with X93 integrated desk module**  
 (alt. X92 / R42 / D44 / F47 / D49 possible)

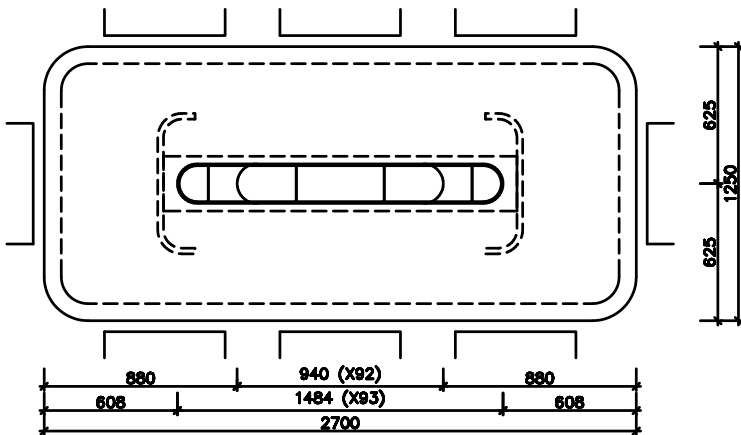

Schloß / Lock / Serrure

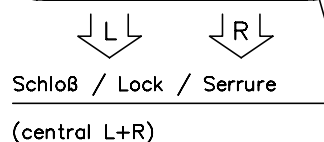
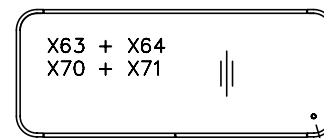
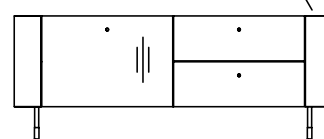

Dimensions in mm

# Upsite

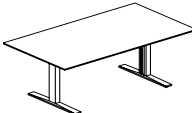
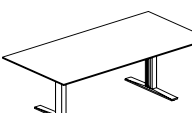
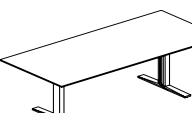
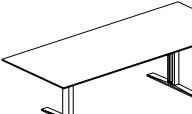
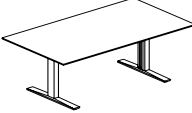
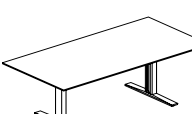
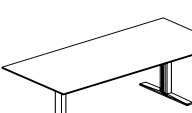
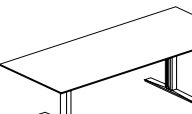

		Dim. in cm W D H	Oak black	Oak light grey titan urban grey  Oak matt Oak smoked Cherry Walnut	Pear  Walnut tobacco	Laminate nano black white stone pine brick mocca		
	<b>U 05</b> <b>Desk</b> Electrically height-adjustable from 74-118 cm. incl. felt cable channel. Edge 13/52mm  Frame chrome Frame black	180 100	5.859 4.985	5.964 5.090	6.627 5.750	6.270 5.396		
	<b>U 07</b> <b>Desk</b> Electrically height-adjustable from 74-118 cm. incl. felt cable channel. Edge 13/52mm  Frame chrome Frame black	200 100	5.961 5.087	6.078 5.206	6.817 5.935	6.404 5.525		
	<b>U 09</b> <b>Desk</b> Electrically height-adjustable from 74-118 cm. incl. felt cable channel. Edge 13/52mm  Frame chrome Frame black	220 100	6.100 5.225	6.231 5.355	7.044 6.159	6.575 5.697		
	<b>U 11</b> <b>Desk</b> Electrically height-adjustable from 74-118 cm. incl. felt cable channel. Edge 13/52mm  Frame chrome Frame black	240 100	6.205 5.328	6.343 5.464	7.229 6.346	6.707 5.827		
	<b>U 06</b> <b>Desk</b>  incl. felt cable channel. Edge 13/52mm  Frame chrome Frame black	180 100 74	4.578 3.925	4.684 4.031	5.348 4.688	4.992 4.334		
	<b>U 08</b> <b>Desk</b>  incl. felt cable channel. Edge 13/52mm  Frame chrome Frame black	200 100 74	4.679 4.027	4.798 4.142	5.536 4.875	5.122 4.467		
	<b>U 10</b> <b>Desk</b>  incl. felt cable channel. Edge 13/52mm  Frame chrome Frame black	220 100 74	4.820 4.167	4.951 4.295	5.764 5.100	5.294 4.634		
	<b>U 12</b> <b>Desk</b>  incl. felt cable channel. Edge 13/52mm  Frame chrome Frame black	240 100 74	4.923 4.268	5.062 4.405	5.951 5.283	5.428 4.767		

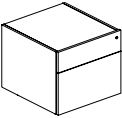
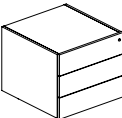
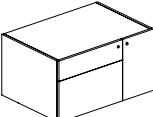
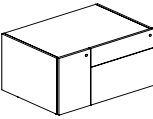
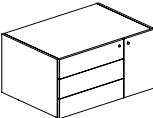
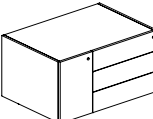
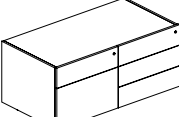
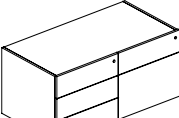

			Dim. in cm W D H	Lacquer silk matt white anthracite aluminium silver black metallic	Oak black	Oak light grey titan urban grey  Oak matt Oak smoked Cherry Walnut	Pear  Walnut tobacco	Laminate nano black white stone pine brick mocca
	U 63	<b>Container</b> Unit with ventilation 1 drawer, 1 drawer for printer  with central locking in front	60 64 54  dimensions printer drawer: 50 48 28	2.080  2.188				
	U 78	<b>Covering panel 60 cm wide</b>		224	266	286	415	264
	U 64	<b>Container</b> 3 drawers  with central locking in front	60 64 54  2.540	2.433				
	U 78	<b>Covering panel 60 cm wide</b>		224	266	286	415	264
	U 65	<b>Container</b> Unit with ventilation 1 drawer, 1 drawer for printer, 1 door for PC  with locks in front	90 64 54  dimensions printer drawer: 50 48 28 dimensions PC compart.: 26 50 48	2.637  2.853				
	U 79	<b>Covering panel 90 cm wide</b>		348	398	428	624	396
	U 66	<b>Container</b> Unit with ventilation 1 drawer, 1 drawer for printer, 1 door for PC  with locks in front	90 64 54  dimensions printer drawer: 50 48 28 dimensions PC compart.: 26 50 48	2.637  2.853				
	U 79	<b>Covering panel 90 cm wide</b>		348	398	428	624	396
	U 67	<b>Container</b> Unit with ventilation 3 drawers, 1 door for PC  with locks in front	90 64 54  dimensions PC compart.: 26 50 48	2.988  3.206				
	U 79	<b>Covering panel 90 cm wide</b>		348	398	428	624	396
	U 68	<b>Container</b> Unit with ventilation 3 drawers, 1 door for PC  with locks in front	90 64 54  dimensions PC compart.: 26 50 48	2.988  3.206				
	U 79	<b>Covering panel 90 cm wide</b>		348	398	428	624	396
	U 70	<b>Container</b> Unit, 4 drawers, 1 drawer for printer  with locks in front	120 64 54  dimensions printer drawer: 50 48 28	3.861  4.079				
	U 80	<b>Covering panel 120 cm wide</b>		445	529	567	830	527
	U 71	<b>Container</b> Unit, 4 drawers, 1 drawer for printer  with locks in front	120 64 54  dimensions printer drawer: 50 48 28	3.861  4.079				
	U 80	<b>Covering panel 120 cm wide</b>		445	529	567	830	527



## Product description

### UPSITE

is a modular system with electrically height-adjustable desks as well as desks with a set height. Rectangular tabletops rest on a chromed or black lacquered T-base frame with lifting columns. Design and construction of the containers — as single container or connected to a toolboard — are in line with the storage system SITE.

### Tops

The tabletops are 25 mm thick and have an MDF core. The edges are available in two different versions:

#### Edge 13 mm:

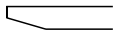

In the optically slim version, a 13 mm thick veneer edge merges into a bevel angled 13° towards the bottom.

#### Edge 52 mm:

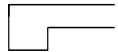

In the block-shaped, optically more present version, the edge is doubled to approx. 52 mm.

The bevel is lacquered anthracite like the bottom of the top. Tabletops are veneered lengthwise. Tabletops in Fenix Nano are also lacquered anthracite underneath. Tabletops in non-standard sizes are possible upon request. The desks are always fitted with a horizontal cable conduit made of felt.

## FENIX NTM

Fenix NTM is a nanotech material of the company Arpa Industriale, which we offer under the label Laminate Nano in our collection.

### Desk electrically height adjustable

The frames (T-base) of the height-adjustable desks offer a range in height from as low as 74 to up to 118 cm. Height adjustment is done electrically.

The two round buttons to regulate the height adjustment are embedded evenly into the desk surface. The height adjustment has a programmed „safety area“ for downwards operation. The downwards movement stops at the last 50 mm and must be restarted at a reduced speed by pressing the button again.

### Desk with a set height

Standard height of table frame is 74 cm. Different table heights ranging from 72 to 77 cm are possible. The table height can be set in 1 cm increments. The chromed lifting columns have a cross section of 10 x 6 cm. The other parts of the frame are powder-coated in RAL 7021 (black grey). The chromed or black lacquered aluminum foot stabilizers complete the high-quality design of the pedestal. Height-adjustable gliders allow levelling the desk. The desks are always delivered with a horizontal felt cable tray. The horizontal cable channel is designed as a molded part made of felt, colored in anthracite-melange. The innovative locking technique provides convenient access to the cable channel and allows adapting the optional electric boxes or cable outlets.

For a standalone desk, the cable management occurs via the supplied vertical cabling. It is attached to the inside of the lifting column on the left or right side. If necessary, the cabling can be switched to the other side without damaging the frame.

Frames mounted in the toolboard are connected through the container via a vertical cabling.

### Power box (can be opened to 1 side)

The power box (U 44) is leveled into the tabletop and finished to match the tabletop. A 17 mm wide cut-out serves as cable outlet. The power box does not yet contain a power strip. Power strips with various configurations must be selected and completed from page 93 on.

The power strips are provided with GST 18 input/output and a connection cord of 2,90 m. A cable for the power connection of two or more power strips can be delivered optionally.

### Meeting table

The tabletops are available in round (Ø 110 cm) or square (110 x 110 cm) shape. Both tables have a central column at a set height. The base plate and column on the round table are round. The base plate and column on the square table are square. The base plate and column are available in polished chrome or black lacquered finish.

### Units

The containers consist of a corpus, a front and covering panel. The corpus and front are available in lacquer silk matt, the covering panels are further available matching the ones of the respective tabletops (lacquer, veneer, HPL). Available widths of the containers are 60, 90 and 120 cm. The containers can stand alone or can be combined into longer toolboards. Full-extension drawers and doors are opened by „push-to-open“ mechanism. The levelling feet are black-grey, distance to the floor is 30 mm.

### Electrification of containers

The cabling of the containers is made possible by a gap in the base panel, all containers provide concealed ventilation in between the top and the back panel. Two silver-coloured profiles form a continuous opening. The back panel can be opened to simplify electrification.

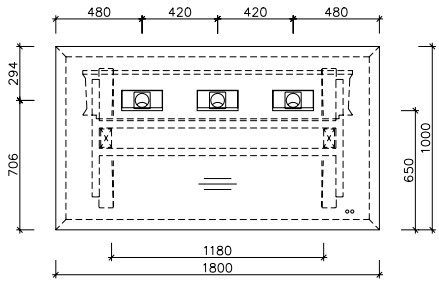

U 05 + U 06 Table  
 U 42 Cable outlet  
 U 44 Power box

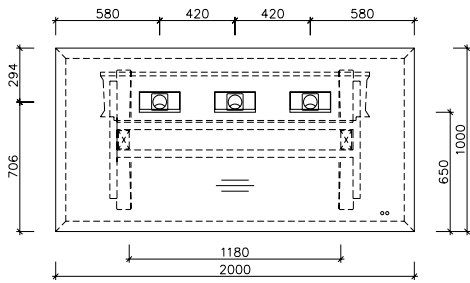

U 07 + U 08 Table  
 U 42 Cable outlet  
 U 44 Power box

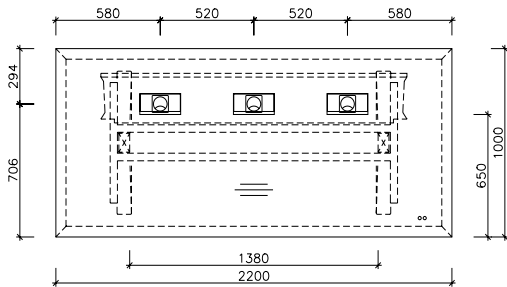

U 09 + U 10 Table  
 U 42 Cable outlet  
 U 44 Power box

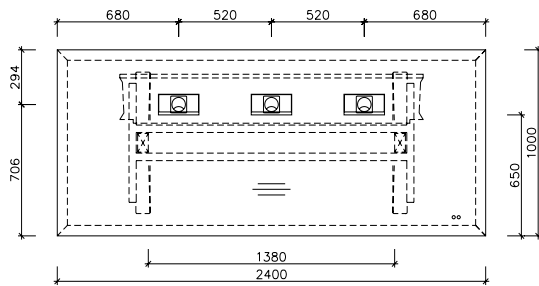

U 11 + U 12 Table  
 U 42 Cable outlet  
 U 44 Power box

Platte = 2000\* // 2200\*\* // 2400\*\*  
 Beinraum: ~ 1180\* // 1380\*\*

Toolboard installation

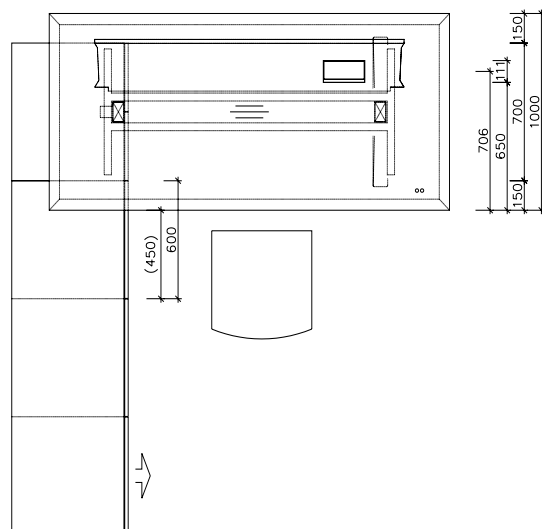



# Pace

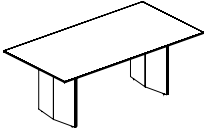
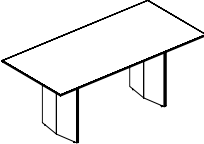
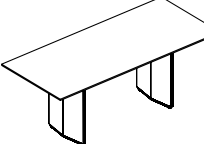
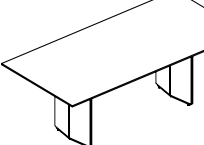
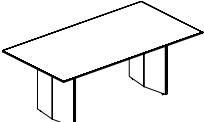
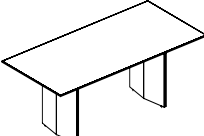
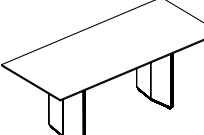
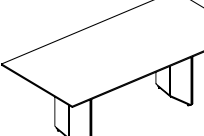

		Dim. in cm W D H	Oak black	Oak light grey titan urban grey	Pear			
				Oak matt Oak smoked Cherry Walnut	Walnut tobacco			
	C 07	<b>Table</b> Electrically height-adjustable from 74-114 cm.	200 105					
		Frame lacquer white Frame lacquer anthracite	8.547 8.547	8.664 8.664	9.531 9.531			
	C 09	<b>Table</b> Electrically height-adjustable from 74-114 cm.	220 105					
		Frame lacquer white Frame lacquer anthracite	8.652 8.652	8.777 8.777	9.731 9.731			
	C 11	<b>Table</b> Electrically height-adjustable from 74-114 cm.	240 105					
		Frame lacquer white Frame lacquer anthracite	8.790 8.790	8.924 8.924	9.966 9.966			
	C 21	<b>Meeting table</b> Electrically height-adjustable from 74-114 cm.	258 125					
		Frame lacquer white Frame lacquer anthracite	9.352 9.352	9.493 9.493	10.878 10.878			
	C 06	<b>Table</b>	200 105 73					
		Frame lacquer white Frame lacquer anthracite	5.999 5.999	6.119 6.119	6.972 6.972			
	C 08	<b>Table</b>	220 105 73					
		Frame lacquer white Frame lacquer anthracite	6.124 6.124	6.253 6.253	7.191 7.191			
	C 10	<b>Table</b>	240 105 73					
		Frame lacquer white Frame lacquer anthracite	6.288 6.288	6.420 6.420	7.448 7.448			
	C 20	<b>Meeting table</b>	258 125 73					
		Frame lacquer white Frame lacquer anthracite	6.719 6.719	6.866 6.866	8.215 8.215			

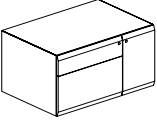
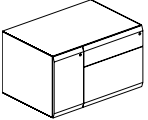
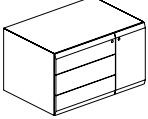
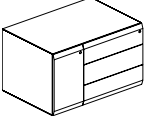
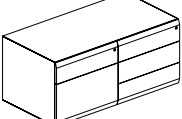
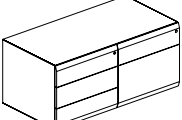
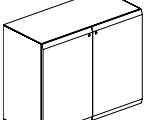
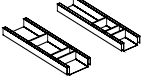

		Dim. in cm W D H	Lacquer white anthracite	Oak black	Oak light grey titan urban grey	Pear	
	C 65	<b>Container</b> Corpus with ventilation	90 62,5 55		2.751	2.795	3.410
	C 65-F	<b>Front panel</b> 1 drawer, 1 drawer for printer, 1 door for PC  with locks in front	dimensions printer drawer: 50 48 28 dimensions PC compart.: 26 50 48	749  969			
	C 66	<b>Container</b> Corpus with ventilation	90 62,5 55		2.751	2.795	3.410
	C 66-F	<b>Front panel</b> 1 drawer, 1 drawer for printer, 1 door for PC  with locks in front	dimensions printer drawer: 50 48 28 dimensions PC compart.: 26 50 48	749  969			
	C 67	<b>Container</b> Corpus with ventilation	90 62,5 55		2.923	2.966	3.583
	C 67-F	<b>Front panel</b> 3 drawers, 1 door for PC  with locks in front	dimensions PC compart.: 26 50 48	896  1.117			
	C 68	<b>Container</b> Corpus with ventilation	90 62,5 55		2.923	2.966	3.583
	C 68-F	<b>Front panel</b> 3 drawers, 1 door for PC  with locks in front	dimensions PC compart.: 26 50 48	896  1.117			
	C 70	<b>Container</b> Corpus	120 62,5 55		3.552	3.598	4.305
	C 70-F	<b>Front panel</b> 4 drawers, 1 drawer for printer  with locks in front	dimensions printer drawer: 50 48 28	1.115  1.336			
	C 71	<b>Container</b> Corpus	120 62,5 55		3.552	3.598	4.305
	C 71-F	<b>Front panel</b> 4 drawers, 1 drawer for printer  with locks in front	dimensions printer drawer: 50 48 28	1.115  1.336			
	C 80	<b>Highboard</b> Corpus Rear laminate anthracite.	100 47,5 82,5		2.448	2.498	3.110
	C 80-F	<b>Pair of doors</b>  with locks in front		831  1.069			
	C 95	<b>Insert with divisions</b> for container C 63-C 71 Anthracite coloured. To arrange freely.		297			

## Product description

### PACE

is a management program with high-adjustable desks as well as desks with a set height. Rectangular tabletops rest on a frame with rhombical crosscuts. Containers and a highboard complete the program with their beveled fronts and reflect the formal language of the table panels.

### Tabletops

The veneered tabletops have a MDF core, they are 31 mm thick, the edges are profiled. A 13 mm thick veneer edge merges into a bevel angled 13° toward the bottom. The bevel is lacquered anthracite like the bottom side of the top. Tabletops are veneered crossways. Tabletops in non-standard sizes are possible on request.

### Frame height-adjustable

The frames of all height-adjustable desks offer a range in height from as low as 74 to up to 114 cm. Height adjustment is done electronically. Both panels have a rhombical crosscut and are cased with sheet steel. The panels are available in lacquer white or anthracite. Non-standard colors are possible on request. The horizontal cable conduit and the welt in the groove of the panels are anthracite as standard.

Height-adjustable glides, integrated in the panels, allow the leveling of the table. The cable inlet is carried out either from below or from the side and is preassembled in either the left or right panel following customer requirements.

### Frame with a set height

The frame of all desks with a set height is construed for either 73 or 75 cm in height. The easy to open frame elements (on both sides) are set up for interior cabling and can be already equipped in the manufacturing process. Frame measurings and available surfaces comply with the height-adjustable desk version. All further (additional) articles like table runners or electronic accessory can be planned out separately / in the same way.

### Tables

The lockable horizontal cable conduit between the panels is accessible from below and allows the setting of the workplace by optional cable outlets or by the sliding leather desk pad.

### Meeting table

The open cable channel is also accessible from below and allows the setting of the optional electric boxes or cable outlets.

Security advice: The CE conformity of the height-adjustment as well as the electrification via the frame panels has been verified by DEKRA Stuttgart. Any change of the technical setting and the subsequent laying of cables by a third party may result in damages or accidents. The CE conformity and the liability of the manufacturer lapse due to any change of the product.

### Container

Containers consist of a corpus and a front panel. The corpus is worked on a miter and veneered crossways like the tabletop. The front panel is available in lacquer white or anthracite, suitable for the table panels, and is chamfered crossways above and below in the identical formal language. The rears are lacquered in the color of the front. Full-extension drawers and doors are opened by „push-to-open“-mechanism. Leveling feet (Ø 55 mm, black) provide a floor distance of 25 mm. Cables are routed into the corpus through apertures in the base panel. Containers C 65 – C 68 provide additional ventilation grilles in the rear for technical equipment. We recommend paying careful attention to equipment manufacturers' instructions regarding the ventilation requirements of electronic devices. Printer cables have to be routed in the preinstalled cable brackets.

All containers are available with locking mechanism. The lock cylinders are positioned in the top right corner of the front drawer panel. If doors are hinged on the right, the lock is on the upper left, and vice versa.

### Leather desk pad

A leather desk pad can be embedded into the desk top. The pad is covered with black leather (customer leather possible). Underneath is a pen tray and 2 DIN A4-sized compartments. On the top left of the leather desk pad is a cable outlet. The pad does not yet contain a power strip. Power strips with various configurations must be selected and completed from page 101 on.

### Cable outlet

The cable outlet (C 42) does not yet contain a power strip. Power strips with various configurations must be selected and completed from page 93 on.

### Power box (can be opened to 1 side)

The power box (C 43/C 44) is leveled into the tabletop and finished to match the tabletop. A 17 mm wide cut-out serves as cable outlet. The power box does not yet contain a power strip. Power strips with various configurations must be selected and completed from page 93 on.

### Power box (can be opened to 2 sides)

The power box (C 49) is leveled into the tabletop and finished to match the tabletop. A 17 mm wide cut-out each serves as cable outlet. The power box does not yet contain a power strip. Power strips with various configurations must be selected and completed from page 93 on.

### Power strips in height-adjustable desks

Without selecting an electric bar height-adjustable tables C 07, C 09, C 11 and C 21 have only one internal wiring for height adjustment, external accessories can not be connected. The electric strip in table is therefore always separately on the item C 41, C 43, C 44 or to order C 45 and is located in the cable channel running under the tabletop. The power strip is accessible from below via the conduit, with the order of a sliding leather desk pad or a power box it is to be reached from above. The complete wiring for the electric strip is already integrated in the delivery from the factory in the table cheek and may not be retrofitted! Security advice: Please note that changes or modifications in the cable guide and into the frame of height-adjustable desks cheeks invalidate the CE conformity and carry with it the responsibility of the manufacturer expires.

### Power strips in desks with set height

For the electrical equipment of the tables with set height all offered electrical boxes and cable outlet variants are available - in each case without power strips. All offered power strips and cable passages are available for desks with a set height. Cabling done by the customer is not limited. Power strips with various configurations must be selected and completed from page 93 on.

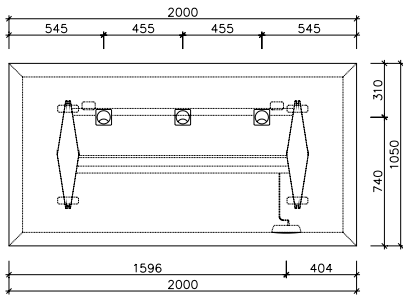

Table C 06 and C 07  
C 42 Cable outlet

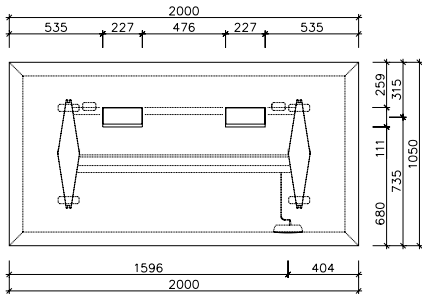

Table C 06 and C 07  
C 44 Power box

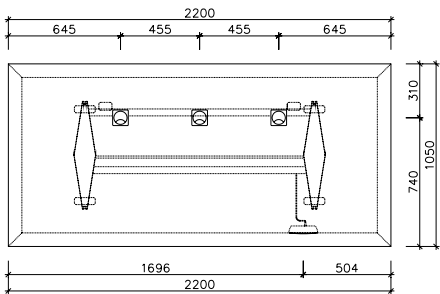

Table C 08 and C 09  
C 42 Cable outlet

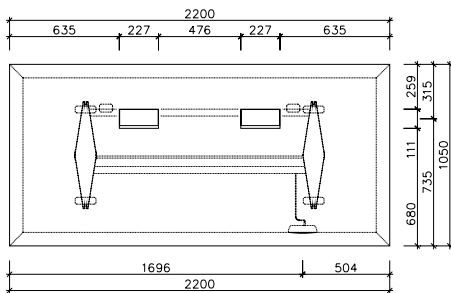

Table C 08 and C 09  
C 44 Power box

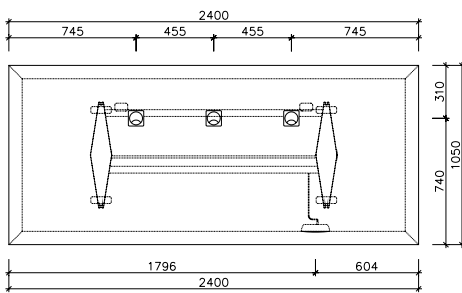

Table C 10 and C 11  
C 42 Cable outlet

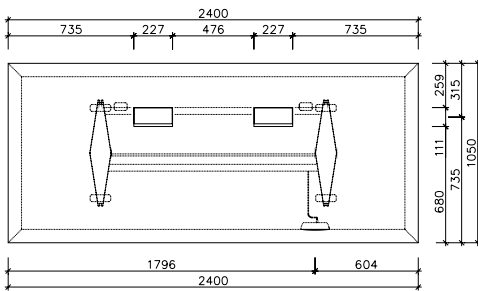
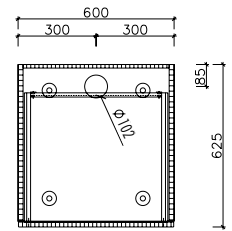
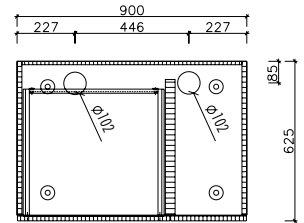

Table C 10 and C 11  
C 44 Power box

C 63/C 64 Container



C 65/C 67 Container



C 66/C 68 Container

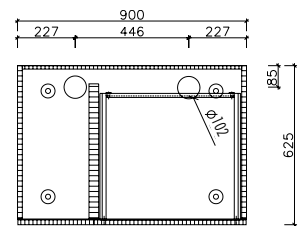

C 70/C 71 Container

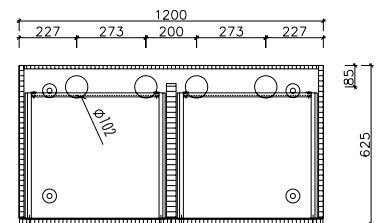

Meeting table C 20 and C 21 / C 42 Cable outlet

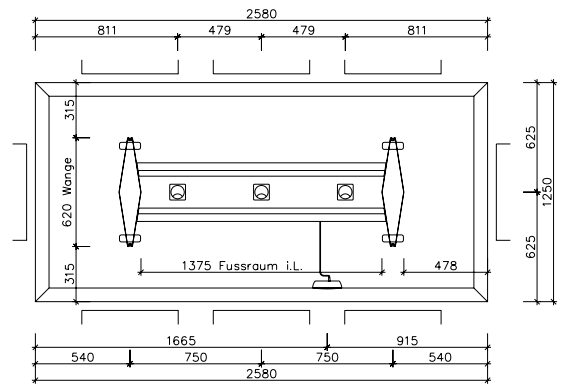



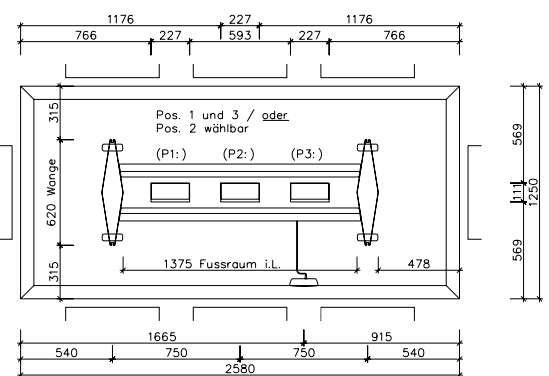



Meeting table C 20 and C 21  
C 43/C 49 Power box for meeting table



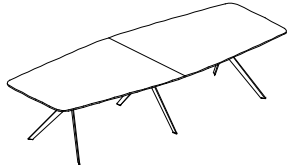

# Star



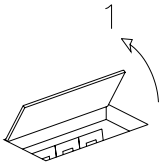
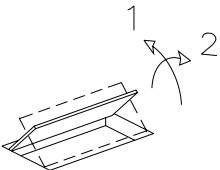

		Dim. in cm W D H	Oak black	Oak light grey titan urban grey	Pear	Laminate nano black white stone pine brick mocca		
	<b>R 21 Meeting table</b> Frame chrome Frame lacquer white or black	Ø 110 73/75	2.571 2.501	2.645 2.570	2.970 2.896	2.782 2.705		
	<b>R 23 Meeting table</b> Frame chrome Frame lacquer white or black	240 120 73/75	5.117 4.960	5.207 5.050	6.042 5.891	5.476 5.312		
	<b>R 25 Meeting table (two-part)</b> Frame chrome Frame lacquer white or black	320 127 73/75	8.038 7.737	8.226 7.920	9.352 9.048	8.655 8.331		
	<b>R 40 Leather desk pad</b> Black leather  ... customer-supplied leather Required leather: 96 cm x 70 cm	85 55 0,4					747 618	
	<b>R 42 Cable outlet</b> Chrome, matt chrome or black. Standard positions see p. 58. Special items on request.	9 9					125	
	<b>R 43 Vertical cabling</b> Chrome, lacquer white or lacquer black. To attach to a table leg.						192	
	<b>R 44 Power box</b> The lid is finished to match the tabletop. The power strip is not included. It must be selected and completed from page 93. Standard positions of the elec. box see p. 55. Special items on request.	23 11					898	
	<b>R 49 Power box (can be opened to 2 sides)</b> The lid is finished to match the tabletop. Can be used in table R 23 / R 25. The power strip is not included. It must be selected and completed from page 93. Standard positions of the power box see p. 55.	23 15					1.522	

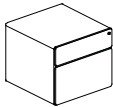
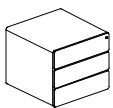
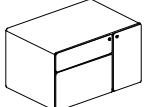
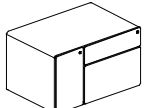
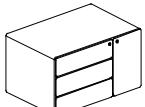
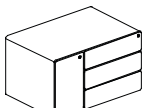
		Dim. in cm W D H	Lacquer aluminium silver black metallic brown metallic silk matt white	Oak black	Oak light grey titan urban grey	Pear  Walnut tobacco	Laminate nano black white stone pine brick mocca
	R 60 <b>Mobile container</b> 3 drawers With central locking device rh. Drawer front is projecting lh or rh and serving as a grip handle.	43 60 55	1.826				
	R 62 <b>Mobile container</b> 1 drawer 1 file drawer With central locking device rh. Drawer front is projecting lh or rh and serving as a grip handle.	43 60 55	1.734				
	R 63 <b>Container</b> Corpus  R 63-F <b>Front panel</b> 1 drawer 1 drawer for printer or filing frame  with central locking in front	60 61,5 55  dimensions printer drawer: 50 48 28	1.834	563  669	598  705	659  764	598  705
	R 64 <b>Container</b> Corpus  R 64-F <b>Front panel</b> 3 drawers  with central locking in front	60 61,5 55	2.057	749  855	794  902	843  950	794  902
	R 65 <b>Container</b> Corpus with ventilation  R 65-F <b>Front panel</b> 1 drawer, 1 drawer for printer or filing frame, 1 door for PC  with locks in front	90 61,5 55  dimensions printer drawer: 50 48 28 dimensions PC compart.: 26 50 48	2.316	860  1.077	915  1.131	1.003  1.218	915  1.131
	R 66 <b>Container</b> Corpus with ventilation  R 66-F <b>Front panel</b> 1 drawer, 1 drawer for printer or filing frame, 1 door for PC  with locks in front	90 61,5 55  dimensions printer drawer: 50 48 28 dimensions PC compart.: 26 50 48	2.316	860  1.077	915  1.131	1.003  1.218	915  1.131
	R 67 <b>Container</b> Corpus with ventilation  R 67-F <b>Front panel</b> 3 drawers, 1 door for PC  with locks in front	90 61,5 55  dimensions PC compart.: 26 50 48	2.541	1.046  1.261	1.114  1.329	1.190  1.403	1.114  1.329
	R 68 <b>Container</b> Corpus with ventilation  R 68-F <b>Front panel</b> 3 drawers, 1 door for PC  with locks in front	90 61,5 55  dimensions PC compart.: 26 50 48	2.541	1.046  1.261	1.114  1.329	1.190  1.403	1.114  1.329



## Product description

### STAR

is a modular system for the workplace. Interesting tabletop shapes rest on an organically styled base. Elegant containers and highboards offer storage space as well as all the necessary functions.

### Tabletops

The tabletops have an MDF core. Veneered tops are 31 mm thick. Corners are rounded. A 13 mm thick veneer edge merges into a bevel (lacquered MDF) angled 13° toward the center. Tabletops are rectangular or freeform; other shapes and sizes are available upon request.

### FENIX NTM

Fenix NTM is a nanotech material of the company Arpa Industriale, which we offer under the label Laminate nano in our collection.

### Frame

The self-supporting steel frame comes finished in chrome-plated, lacquer white or black. Other colors are available upon request. The attachment plate and upper frame are generally coated black. The frame comes in standard table heights of 73 cm and 75 cm. Table legs have black plastic gliders. Horizontal cable management is facilitated by a black metal cable conduit fitted to the upper frame. The vertical cable guide (R 43) matches the frame and attaches to the side of it.

### Mobile container

Mobile Containers are offered in lacquer aluminium silver, lacquer black metallic, lacquer brown metallic and lacquer matt white. The 1,5 cm projecting end of the front pieces of the drawers serve a grip handle for opening the drawers and file extensions. The mobile containers are provided with damped self-closing drawers, automatic drawer stop and central locking. Rh and lh mobile Containers are available. The projecting ends of the drawer front pieces of a rh mobile container are on the left side. The castors of the containers are partly hidden. Both castors in front are fixable.

### Container

Containers consist of a corpus and a front panel. The corpus is available in lacquer aluminium silver, lacquer black metallic, lacquer brown metallic and lacquer silk matt white. The transition from the top and base to the side panels is rounded with a 19 mm radius, as are the edges of the front panel, which are finished to match the tabletop. Doors and full-extension drawers can be opened with a gentle push. Black height-adjustable glides (Ø 55 mm) support the base panel with 25 mm clearance.

Generous cable apertures in the base panel also assure adequate air inflow. Containers with a computer compartment are also fitted with two ventilation grilles in the back panel. We recommend paying careful attention to equipment manufacturers' instructions regarding the ventilation requirements of electronic devices. The deep drawers can also accommodate a printer. Printer cables should be clipped into the preinstalled cable brackets. All containers are available with locking mechanism. The lock cylinder is positioned in the top right corner of the front drawer panel. If doors are hinged on the right, the lock is on the upper left, and vice versa. All units supplied in one order are fitted with identical locks.

### Power box (can be opened to 1 side)

The power box (R 44) is leveled into the tabletop and finished to match the tabletop. A 17 mm wide cut-out serves as cable outlet. The power box does not yet contain a power strip. Power strips with various configurations must be selected and completed from page 93 on.

### Power box (can be opened to 2 sides)

The power box (R 49) is leveled into the tabletop and finished to match the tabletop. A 17 mm wide cut-out each serves as cable outlet. The power box does not yet contain a power strip. Power strips with various configurations must be selected and completed from page 93 on.

All power strips come fitted with a GST18 power input/output. The length of cable is 2,90 m. Cables for connecting two or more power strips, as well as other options for outfitting power strips, are available upon request.

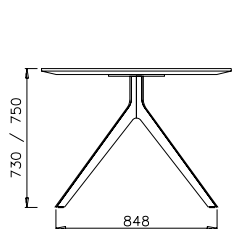
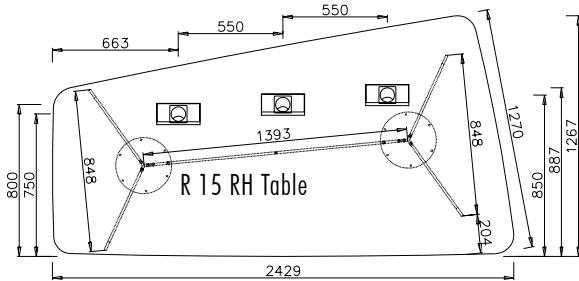
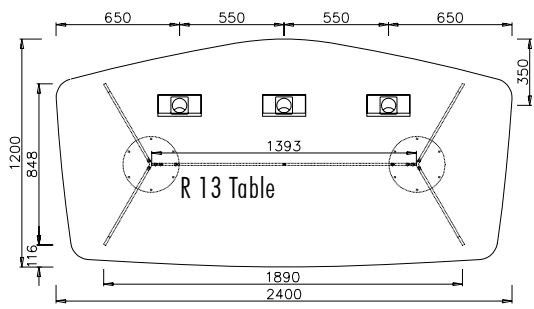
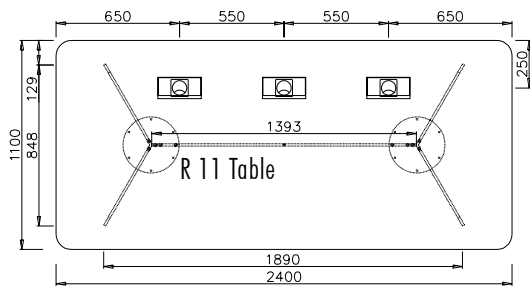
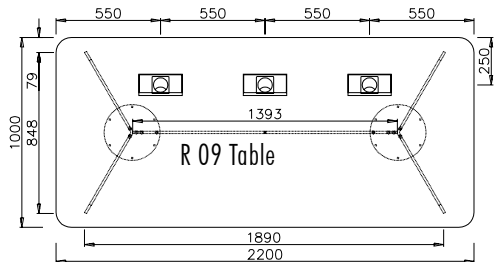
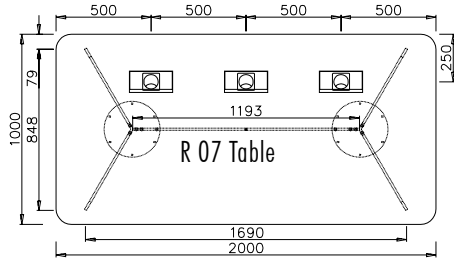
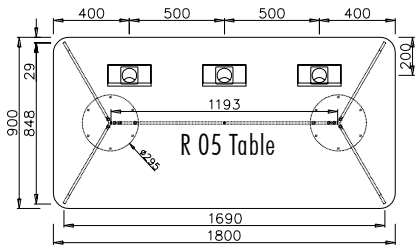

R 07 Side view

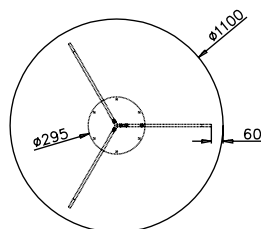

R 21 Meeting table

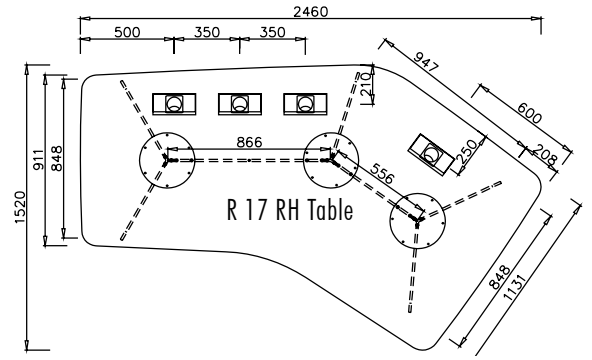

Meetin Table R 23 / R 25  
R 44 / R 49 Power box for meeting table

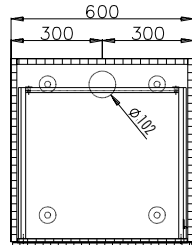
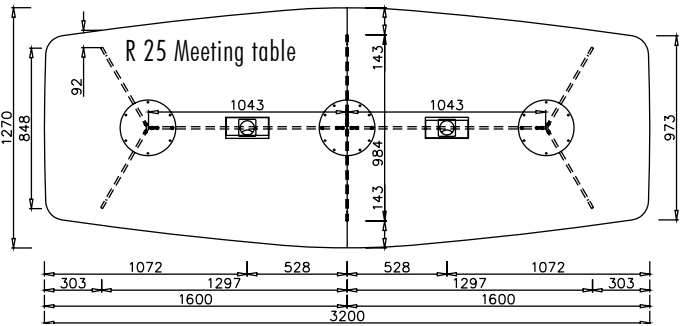
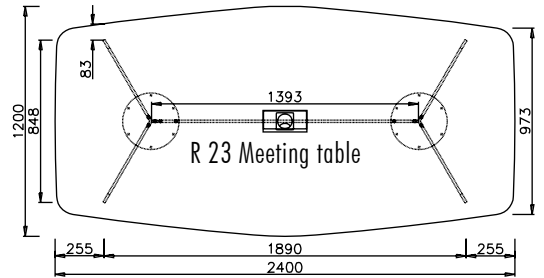

R 63/R 64 Container

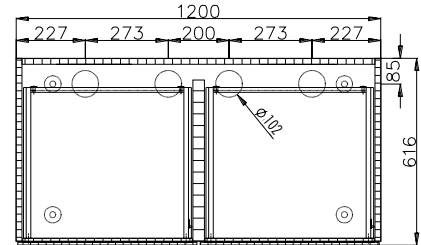

R 70/R 71 Container

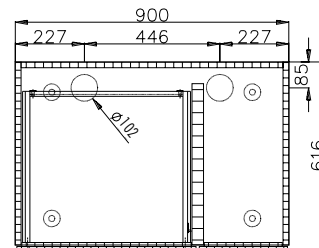



R 65-R 68 Container



# Talk

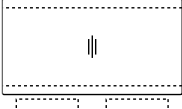

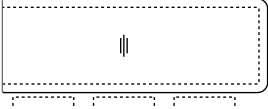
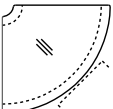
		Dim. in cm W D H	Oak black	Oak light grey titan urban grey  Oak matt Oak smoked Cherry Walnut	Pear  Walnut tobacco	Laminate uni black white grey stone mocca  Further finishes on request.	Laminate nano black white stone pine brick mocca	
* Table segment not to use as single table, ** Installation of power box A72 not possible								
	A 03	<b>Rectangle</b>	160 85 73	1.867	1.933	2.372	1.634	2.040
	A 03-K	<b>Cable conduit</b> Anthracite-coloured coating						542
	A 03-S	<b>Modesty Panel</b> Anthracite-coloured coating	25					555
	A 04	<b>Rectangle</b>	220 85 73	2.256	2.338	2.953	1.987	2.475
	A 04-K	<b>Cable conduit</b> Anthracite-coloured coating						663
	A 04-S	<b>Modesty Panel</b> Anthracite-coloured coating	25					581
	A 06	<b>End top</b>	180 85 73	1.961	2.034	2.532	1.732	2.162
	A 06-K	<b>Cable conduit</b> Anthracite-coloured coating						542
	A 06-S	<b>Modesty Panel</b> Anthracite-coloured coating	25					555
	A 07	<b>End top</b>	240 85 73	2.373	2.459	3.134	2.083	2.599
	A 07-K	<b>Cable conduit</b> Anthracite-coloured coating						663
	A 07-S	<b>Modesty Panel</b> Anthracite-coloured coating	25					581
	A 42* A 42**	<b>Quarter circle</b>	95 85 73 radius	1.510	1.574	1.948	1.313	1.642
	A 42-K	<b>Cable conduit</b> Anthracite-coloured coating						613
	A 42-S	<b>Modesty Panel</b> Anthracite-coloured coating	25					504

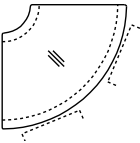
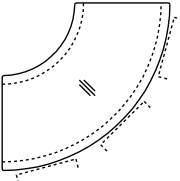
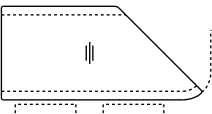
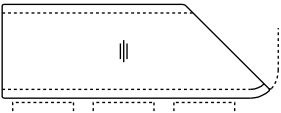
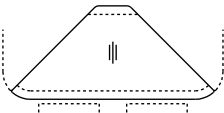
		Dim. in cm W D H	Oak black	Oak light grey titan urban grey	Pear	Laminate uni	Laminate nano	
* Table segment not to use as single table								
	A 43*	Quarter circle	110 85 73 radius	1.676	1.744	2.206	1.456	1.821
	A 43-K	<b>Cable conduit</b> Anthracite-coloured coating						661
	A 43-S	<b>Modesty Panel</b> Anthracite-coloured coating	25					555
	A 45*	Quarter circle	150 85 73 radius	2.338	2.425	3.146	2.061	2.573
	A 45-K	<b>Cable conduit</b> Anthracite-coloured coating						849
	A 45-S	<b>Modesty Panel</b> Anthracite-coloured coating	25					586
	A 63	Corner top	190 85 73	1.986	2.059	2.561	1.742	2.173
	A 63-K	<b>Cable conduit</b> Anthracite-coloured coating						465
	A 63-S	<b>Modesty Panel</b> Anthracite-coloured coating	25					510
	A 64	Corner top	250 85 73	2.378	2.464	3.145	2.088	2.605
	A 64-K	<b>Cable conduit</b> Anthracite-coloured coating						637
	A 64-S	<b>Modesty Panel</b> Anthracite-coloured coating	25					559
	A 66	Head top	200 85 73	1.940	2.015	2.525	1.689	2.114
	A 66-K	<b>Cable conduit</b> Anthracite-coloured coating						384
	A 66-S	<b>Modesty Panel</b> Anthracite-coloured coating	25					454





## Product description

### TALK

is an intelligent table system for temporary or permanent conference facilities, or for meetings or seminars. Thanks to its modular construction, it allows a variety of different tabletop sizes and shapes to be combined. The chrome-plated, light-weight and elegantly designed aluminum frame not only guarantees stability but also maximum leg freedom. In the case of table assemblies, it also serves as a patented connecting element between two tabletops. The table legs are secured to the tabletop by means of two elegantly designed levers.

### Tabletops

The tabletops are manufactured with an MDF core. The tabletop thickness varies depending on the selected surface material. The tops are available as a veneer (31 mm thick, cross-veneered) or laminated (32 mm thick). The lengthwise edges of the tabletops are beveled making them appear thin and light. A 13 mm thick veneer edge merges into a bevel (lacquered MDF) angled 13° toward the center. The leading edges are not beveled. All corners are rounded to a radius of 15 mm. Other tabletop sizes and shapes, along with non-standard wood types and surface finishes, are available on request.

### FENIX<sup>NTM</sup>

Fenix NTM is a nanotech material of the company Arpa Industriale, which we offer under the label Laminate nano in our collection.

### Frame

The chrome-plated aluminium frame can either be located under the join between two tabletops or inserted between them. The frame is fastened to the tabletop by means of two levers that are operated without the need for tools. This allows the position of the frame, and the arrangement of the tables, to be easily adjusted at any time. Black plastic glides are used to compensate for irregularities in the floor. Trolleys for transporting and storing unused tabletops and frames are available for purchase.

### Power box (can be opened to 1 side)

The power box (A 72) is leveled into the tabletop and finished to match the tabletop. A 17 mm wide cut-out serves as cable outlet. The power box does not yet contain a power strip. Power strips with various configurations must be selected and completed from page 93 on.

All power strips come fitted with a GST18 power input/output. The length of cable is 2,90 m. Cables for connecting two or more power strips, as well as other options for outfitting power strips, are available upon request.

### Cable conduits (horizontal cabling)

The spacious cable conduits are retractable, and can also be mounted and removed without the need for tools. They also function as a modesty panel when mounted. The cable conduits have a cross-sectional dimension of 175 x 75 mm. The cross-section reduces to approx. 30 x 75 mm at the location of the power boxes.

### Vertical cabling element

The chrome-plated vertical cabling element can be fastened to any of the table legs. The cable conduits have a cross-sectional dimension of approx. 40 x 25 mm.

### Modesty panel

The modesty panels are assembled underneath the tabletop or, in conjunction with a cable conduit, to this (tool-free).

A 03 Rectangle  
A 72 Power box

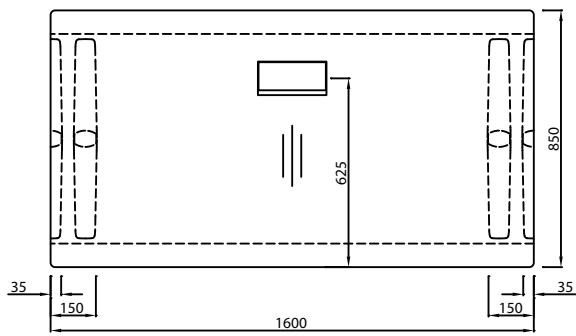

A 06 End top

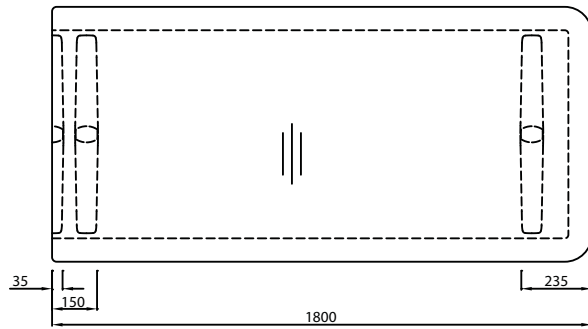

Lateral cut

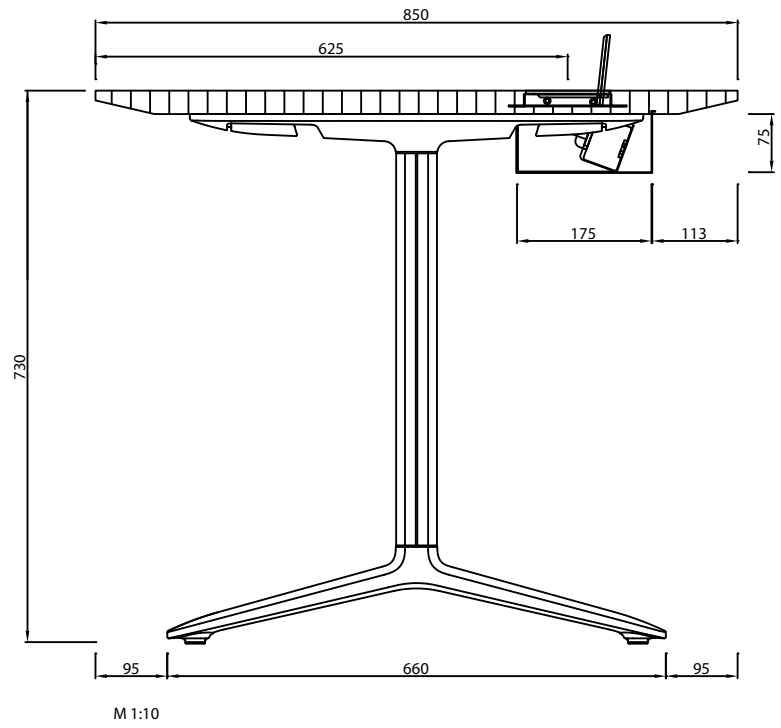

A 64 Corner top  
A 66 Head top

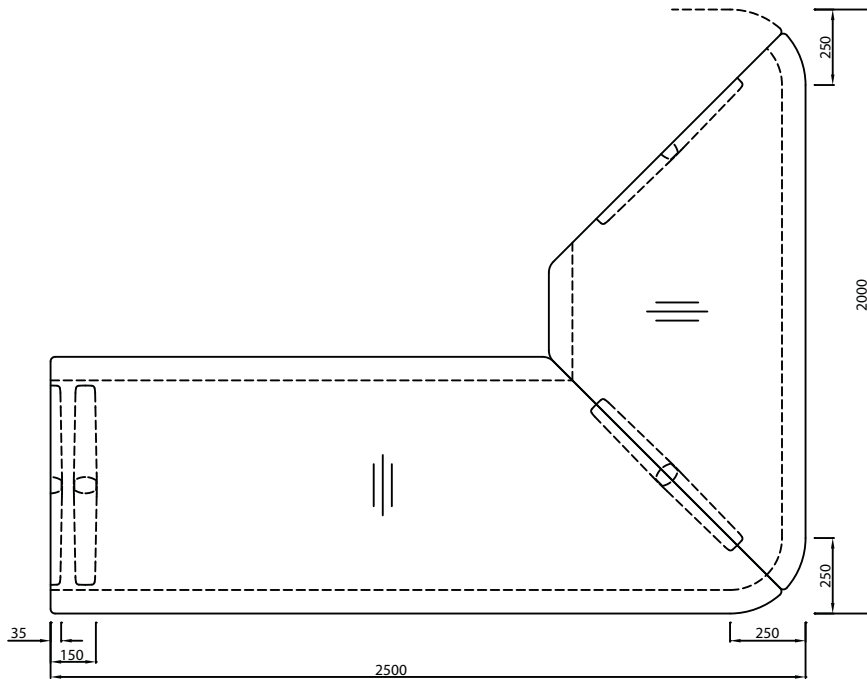

## Prices of example units

Scale 1:100

A

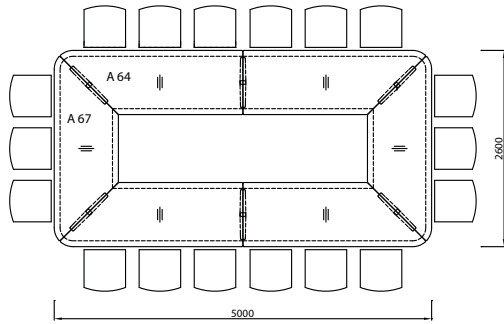

Euro 18.998 \*

B

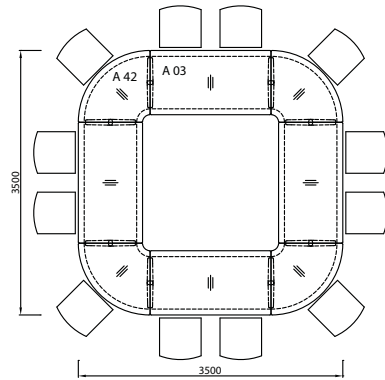

Euro 19.796 \*

C

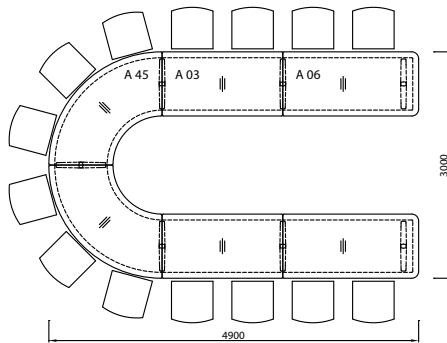

Euro 17.831 \*

D

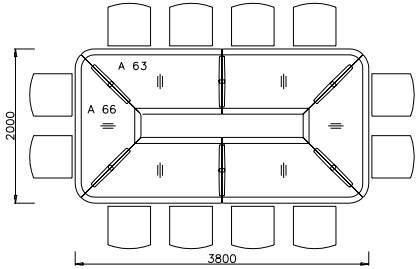

Euro 16.592 \*

E

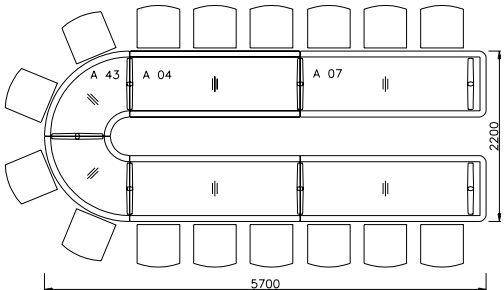

Euro 18.129 \*



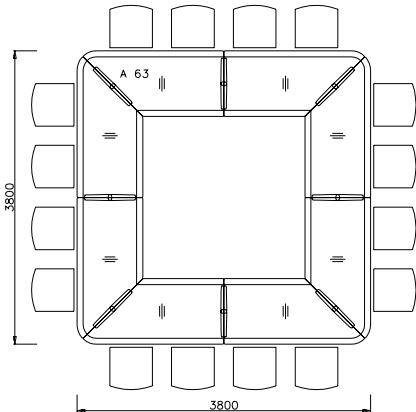

F

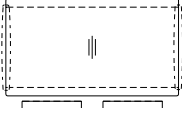

Euro 22.240 \*

# Convo

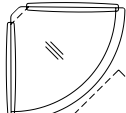

		Dim. in cm W D H	Oak black	Oak light grey titan urban grey	Pear	Laminate uni black white grey stone mocca Further finishes on request.	Laminate nano black white stone pine brick mocca	
	V 03	<b>Rectangle</b> Frame Aluminium chrome Frame Aluminium polished Frame powder-coated white, antracite or RAL	160 90 73					
	V 03-K	<b>Cable conduit</b> Felt anthracite		2.893 2.837 2.837	2.962 2.905 2.905	3.437 3.367 3.367	2.740 2.687 2.687	3.116 3.055 3.055
	V 03-S	<b>Modesty Panel</b> Felt anthracite	28					458
	V 04	<b>Rectangle</b> Frame Aluminium chrome Frame Aluminium polished Frame powder-coated white, antracite or RAL	215 90 73					
	V 04-K	<b>Cable conduit</b> Felt anthracite		3.310 3.245 3.245	3.400 3.334 3.334	4.044 3.963 3.963	3.105 3.044 3.044	3.604 3.533 3.533
	V 04-S	<b>Modesty Panel</b> Felt anthracite	28					472
	V 06	<b>End top</b> Frame Aluminium chrome Frame Aluminium polished Frame powder-coated white, antracite or RAL	185 90 73					
	V 06-K	<b>Cable conduit</b> Felt anthracite		3.572 3.503 3.503	3.645 3.573 3.573	4.197 4.115 4.115	3.404 3.337 3.337	3.835 3.761 3.761
	V 06-S	<b>Modesty Panel</b> Felt anthracite	28					463
	V 07	<b>End top</b> Frame Aluminium chrome Frame Aluminium polished Frame powder-coated white, antracite or RAL	240 90 73					
	V 07-K	<b>Cable conduit</b> Felt anthracite		3.989 3.910 3.910	4.079 4.000 4.000	4.803 4.708 4.708	3.768 3.691 3.691	4.321 4.237 4.237
	V 07-S	<b>Modesty Panel</b> Felt anthracite	28					472
	V 42*	<b>Quarter circle</b> Frame Aluminium chrome Frame Aluminium polished Frame powder-coated white, antracite or RAL	97,5 radius 73					
	V 42-K	<b>Cable conduit</b> Felt anthracite		2.723 2.670 2.670	2.778 2.723 2.723	3.199 3.139 3.139	2.603 2.553 2.553	2.936 2.877 2.877
	V 42-S	<b>Modesty Panel</b> Felt anthracite	28					303

\* Installation of power box V72 not possible

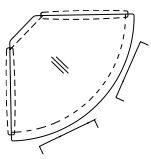
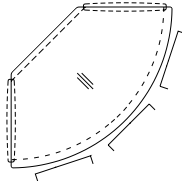
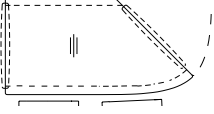
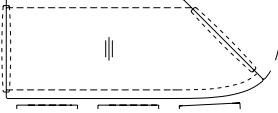
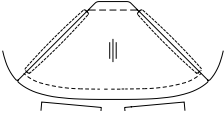
		Dim. in cm W D H	Oak black	Oak light grey titan urban grey	Pear	Laminate uni black white grey stone mocca Further finishes on request.	Laminate nano black white stone pine brick mocca			
	V 43	<b>Quarter circle</b> Frame Aluminium chrome Frame Aluminium polished Frame powder-coated white, antracite or RAL	112,5 radius	73	2.905 2.850 2.850	2.976 2.919 2.919	3.483 3.413 3.413	2.769 2.716 2.716	3.164 3.104 3.104	
	V 43-K	<b>Cable conduit</b> Felt anthracite							261	
	V 43-S	<b>Modesty Panel</b> Felt anthracite		28					330	
	V 45	<b>Quarter circle</b> Frame Aluminium chrome Frame Aluminium polished Frame powder-coated white, antracite or RAL	152,5 radius	73	3.512 3.443 3.443	3.600 3.529 3.529	4.390 4.303 4.303	3.307 3.244 3.244	3.905 3.828 3.828	
	V 45-K	<b>Cable conduit</b> Felt anthracite							378	
	V 45-S	<b>Modesty Panel</b> Felt anthracite		28					448	
	V 63	<b>Corner top</b> Frame Aluminium chrome Frame Aluminium polished Frame powder-coated white, antracite or RAL	190	90	73	3.055 2.995 2.995	3.145 3.081 3.081	3.638 3.569 3.569	2.840 2.785 2.785	3.297 3.232 3.232
	V 63-K	<b>Cable conduit</b> Felt anthracite								378
	V 63-S	<b>Modesty Panel</b> Felt anthracite		28					448	
	V 64	<b>Corner top</b> Frame Aluminium chrome Frame Aluminium polished Frame powder-coated white, antracite or RAL	250	90	73	3.487 3.416 3.416	3.582 3.513 3.513	4.281 4.196 4.196	3.257 3.193 3.193	3.795 3.721 3.721
	V 64-K	<b>Cable conduit</b> Felt anthracite								398
	V 64-S	<b>Modesty Panel</b> Felt anthracite		28					468	
	V 66	<b>Head top</b> Frame Aluminium chrome Frame Aluminium polished Frame powder-coated white, antracite or RAL	210	90	73	3.009 2.951 2.951	3.091 3.029 3.029	3.604 3.535 3.535	2.837 2.781 2.781	3.272 3.206 3.206
	V 66-K	<b>Cable conduit</b> Felt anthracite								262
	V 66-S	<b>Modesty Panel</b> Felt anthracite		28					331	

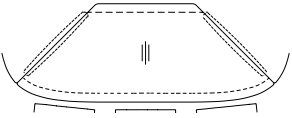
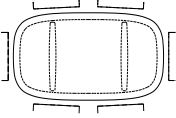
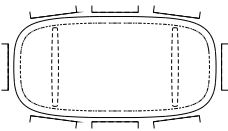
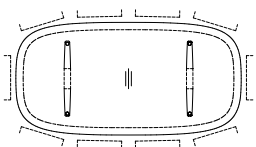
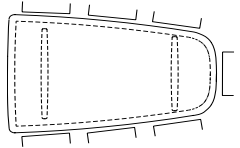
		Dim. in cm W D H	Oak black	Oak light grey titan urban grey	Pear	Laminate uni	Laminate nano	
				Oak matt Oak smoked Cherry Walnut	Walnut tobacco	black white grey stone mocca Further finishes on request.	black white stone pine brick mocca	
	<b>V 67</b> <b>Head top</b> Frame Aluminium chrome Frame Aluminium polished Frame powder-coated white, antracite or RAL	270 90 73	3.513 3.444 3.444	3.605 3.537 3.537	4.311 4.227 4.227	3.283 3.217 3.217	3.827 3.752 3.752	
	<b>V 67-K</b> <b>Cable conduit</b> Felt anthracite							387
	<b>V 67-S</b> <b>Modesty Panel</b> Felt anthracite	28						454
	<b>V 13</b> <b>Meeting table</b> Frame Aluminium chrome Frame Aluminium polished Frame powder-coated white, antracite or RAL	180 100 73	4.523 4.434 4.434	4.601 4.507 4.507	5.225 5.122 5.122	4.201 4.122 4.122	4.907 4.808 4.808	
	<b>V 23</b> <b>Meeting table</b> Frame Aluminium chrome Frame Aluminium polished Frame powder-coated white, antracite or RAL	240 120 73	5.632 5.519 5.519	5.722 5.609 5.609	6.703 6.570 6.570	5.229 5.127 5.127	6.113 5.993 5.993	
	<b>V 25</b> <b>Meeting table</b> Frame Aluminium chrome Frame Aluminium polished Frame powder-coated white, antracite or RAL	280 140 73	7.771 7.618 7.618	7.894 7.739 7.739	9.249 9.066 9.066	7.214 7.074 7.074	8.436 8.269 8.269	
	<b>V 22</b> <b>Meeting table</b> Frame Aluminium chrome Frame Aluminium polished Frame powder-coated white, antracite or RAL	240 148 73	5.923 5.805 5.805	6.037 5.918 5.918	7.245 7.102 7.102	5.756 5.642 5.642	6.675 6.543 6.543	

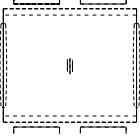
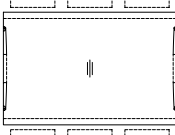
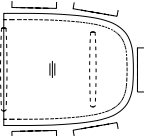
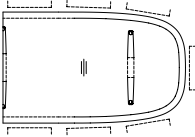
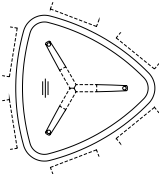
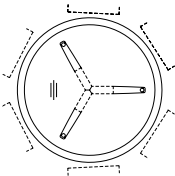
		Dim. in cm W D H	Oak black	Oak light grey titan urban grey  Oak matt Oak smoked Cherry Walnut	Pear  Walnut tobacco	Laminate uni black white grey stone mocca  Further finishes on request.	Laminate nano black white stone pine brick mocca
	V 31 <b>Meeting table</b> Frame Aluminium chrome Frame Aluminium polished Frame powder-coated white, antracite or RAL	160 140 73	4.159 4.076 4.076	4.282 4.197 4.197	4.996 4.896 4.896	3.844 3.771 3.771	4.481 4.394 4.394
	V 32 <b>Meeting table</b> Frame Aluminium chrome Frame Aluminium polished Frame powder-coated white, antracite or RAL	215 140 73	5.737 5.621 5.621	5.910 5.791 5.791	6.891 6.757 6.757	5.304 5.202 5.202	6.181 6.061 6.061
	V 33 <b>Meeting table</b> Frame Aluminium chrome Frame Aluminium polished Frame powder-coated white, antracite or RAL	160 140 73	4.759 4.669 4.669	4.878 4.783 4.783	5.590 5.482 5.482	4.367 4.282 4.282	5.112 5.010 5.010
	V 34 <b>Meeting table</b> Frame Aluminium chrome Frame Aluminium polished Frame powder-coated white, antracite or RAL	230 140 73	6.759 6.625 6.625	6.925 6.787 6.787	7.934 7.781 7.781	6.199 6.082 6.082	7.257 7.115 7.115
	V 15 <b>Meeting table</b> Frame Aluminium chrome Frame Aluminium polished Frame powder-coated white, antracite or RAL	162,5 155 73	4.237 4.168 4.168	4.350 4.281 4.281	5.201 5.132 5.132	3.960 3.890 3.890	4.617 4.549 4.549
	V 19 <b>Meeting table</b> Frame Aluminium chrome Frame Aluminium polished Frame powder-coated white, antracite or RAL	Ø 155 73	4.237 4.168 4.168	4.350 4.281 4.281	5.201 5.132 5.132	3.960 3.890 3.890	4.617 4.549 4.549

		Dim. in cm W D H					
V 80	<b>Vertical cabling</b> Textile. For attachment to the table leg.		223				
V 81	<b>Horizontal cabling</b> Textile. For attachment below tabletop.		146				
V 72	<b>Power box</b> Lid is finished to match the tabletop. Access to the conduit. The power strip is not included. It must be selected and completed from page 93. Standard positions of the power box see p. 72. Special items on request.	23 11	899				
V 92	<b>Power box (can be opened to 2 sides)</b> Lid is finished to match the tabletop. Access to the conduit. Can be used (like V72) in table V13 - V23 and V31/V33. The power strip is not included. It must be selected and completed from page 93.	23 15	1.270				

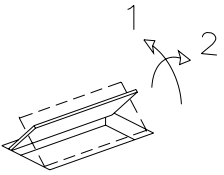
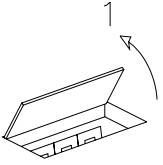

## Product description

### CONVO

is a modular table programme for stationary meeting and conference systems. It offers a wide selection of tabletop sizes and shapes.

CONVO's prominent feature are the outward-angled leg pairs, that are connected through a cross profile in the center. Different lengths of the cross profile match the spacing of the leg pairs to the depth and shape of the tabletop. Leg pairs are available in chrome, white or anthracite coating or upon wish coated in any RAL coloring.

#### Tabletops

The tabletops have an MDF core. Final thickness varies depending on the finishing material used. Available finishes include veneered (31 mm thick, cross-veneered) or laminated (32 mm). The long edges of the tabletops are chamfered from below. The table edge has a thickness of 13mm that merges into a lacquered MDF bevel running inward at a 13° angle. The short edges are not beveled. All corners are rounded with a 15mm radius. This does not apply to table systems consisting of V31 and V 33 tabletops. Other table sizes and forms as well as custom woods and finishes are available on request.

### FENIX<sup>NTM</sup>

Fenix NTM is a nanotech material manufactured by Arpa Industriale and listed in our collection as Laminate nano.

#### Frame

The chrome-plated legs and the aluminium supports form the table base. They can be placed flush with the tabletop or offset.

The base is attached to the tabletop with black coated mounting plates. Black plastic slides can be adjusted for levelling. The tabletop height is 73 cm.

#### Power box (can be opened to 1 side)

The power box (V 72) is leveled into the tabletop and finished to match the tabletop. A 17 mm wide cut-out serves as cable outlet. The power box provides access to the power strips in the horizontal cable conduit, which keeps cables neatly out of view. The power box does not yet contain a power strip. Power strips with various configurations must be selected and completed from page 93 on.

#### Power box (can be opened to 2 sides)

The power box (V 92) is leveled into the tabletop and finished to match the tabletop. A 17 mm wide cut-out each serves as cable outlet. The power box does not yet contain a power strip. Power strips with various configurations must be selected and completed from page 93 on.

All power strips are equipped with GST18 input and output connections. The connection cable is 2.9 m in length. Two or more power strips can be fitted with connection cables on request.

#### Cable conduits and modesty screens

The horizontal cable conduits and modesty screens are made of sculptured felt and attached independently to the tabletop. These components must be ordered separately.

The innovative closure mechanism ensures easy access to the cable conduit and thus to the power strip and power box. The cable conduit measures 180 x 80 mm, narrowing to 30 x 80 mm at the power box.

#### Vertical cabling element

The flexible cable covers can be attached to the inside of the table legs or anywhere under the tabletop using adapters. Their cross-section measures 40 x 20 mm.

V 03 Rectangle  
V 72 Power box

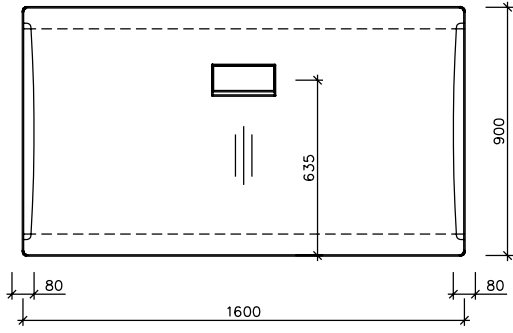

V 06 End top

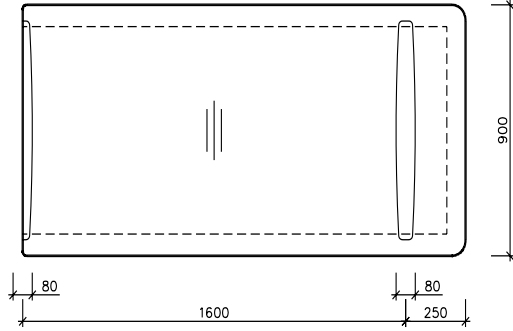

V 64 Corner top  
V 66 Head top

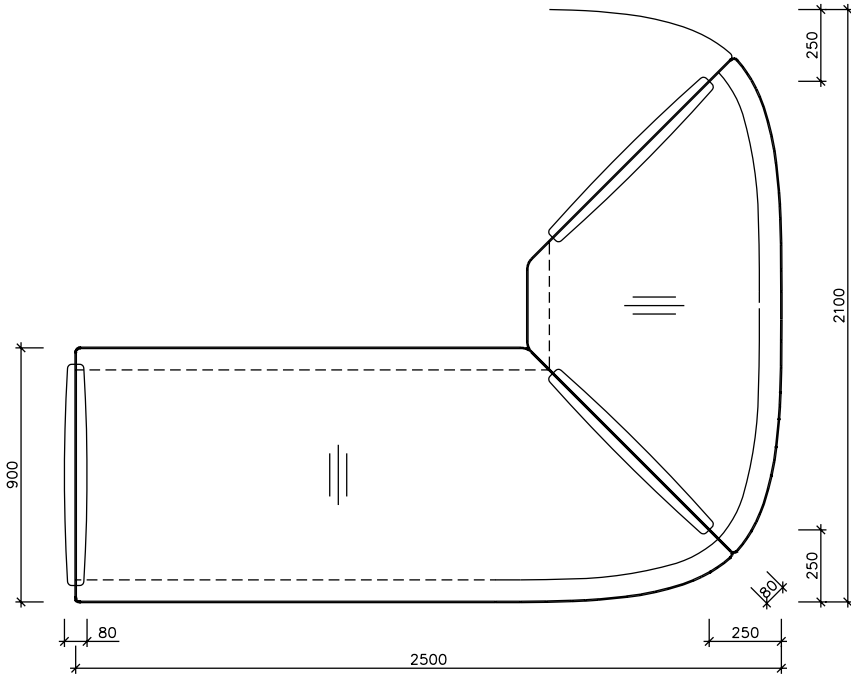

Lateral cut

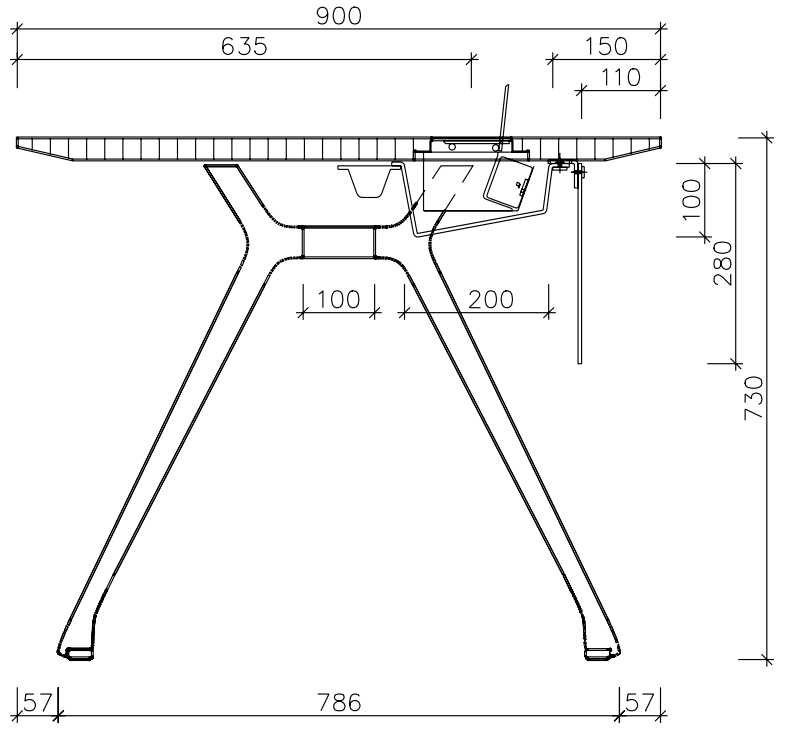

## Prices of example units

Scale 1:100

A

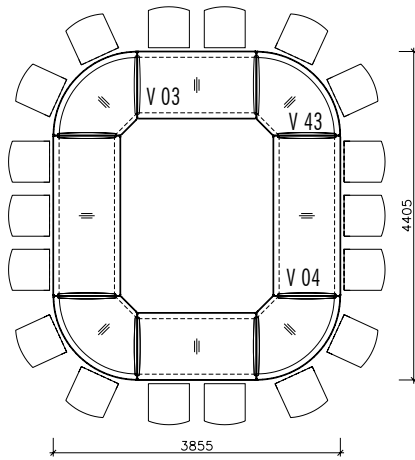

Euro 24.628 \*

B

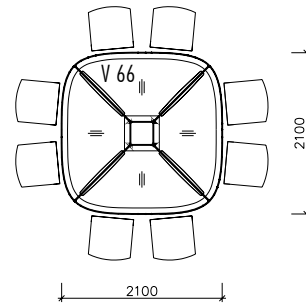

Euro 12.364 \*

C

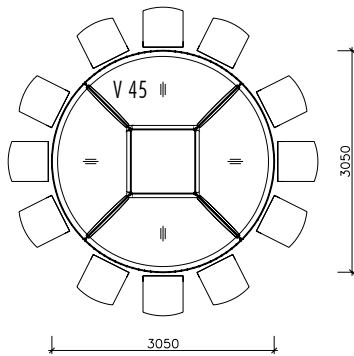

Euro 14.400 \*

D

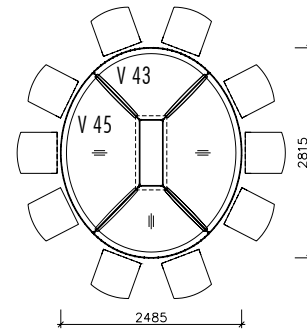

Euro 13.152 \*

E

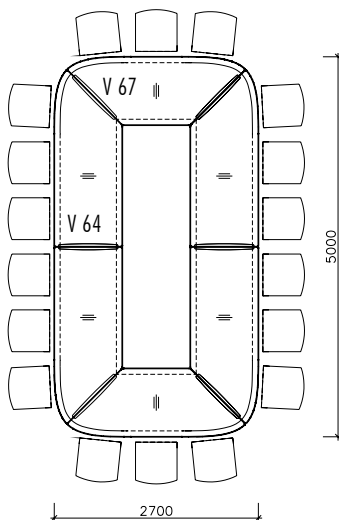

Euro 21.538 \*

F

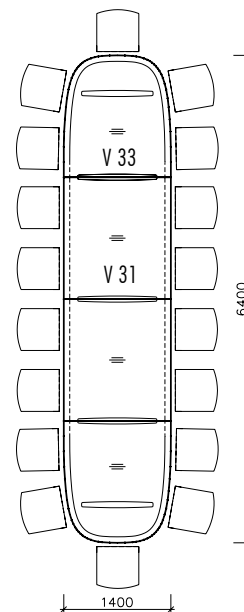









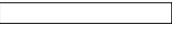
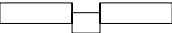

Euro 18.320 \*

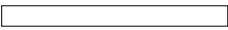
\* Retail prices in Euro. Wood finish oak light/grey titan/urban grey/. Frame chrom.

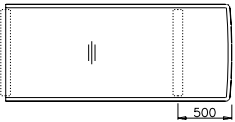
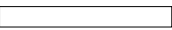

# Tune

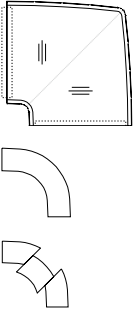
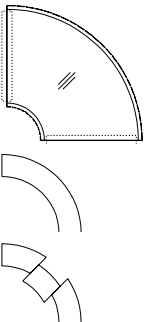
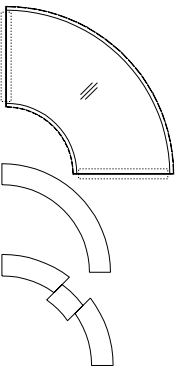

		Dim. in cm W D H	Oak black	Oak light grey titan urban grey  Oak matt Oak smoked Cherry Walnut	Pear  Walnut tobacco	Laminate nano black white stone pine brick mocca		
   	T 03	<b>Inner top</b> Frame chrome	160 90 73	3.037	3.109	3.437	3.139	
	T 03-1	<b>Desk pad</b> Leather black						700
	T 03-2	<b>Desk pad with sliding element</b> Leather black						1.761
	T 03-S	<b>Modesty panel</b> Anthracite-coloured coating						650
   	T 04	<b>Inner top</b> Frame chrome	220 90 73	3.322	3.422	3.844	3.402	
	T 04-1	<b>Desk pad</b> Leather black						825
	T 04-2	<b>Desk pad with sliding element</b> Leather black						1.895
	T 04-S	<b>Modesty panel</b> Anthracite-coloured coating						711
   	T 06	<b>End top</b> Frame chrome	210 90 73	4.212	4.312	4.779	4.399	
	T 06-1	<b>Desk pad</b> Leather black						700
	T 06-2	<b>Desk pad with sliding element</b> Leather black						1.761
	T 06-S	<b>Modesty panel</b> Anthracite-coloured coating						650
   	T 07	<b>End top</b> Frame chrome	270 90 73	4.478	4.603	5.164	4.638	
	T 07-1	<b>Desk pad</b> Leather black						825
	T 07-2	<b>Desk pad with sliding element</b> Leather black						1.895
	T 07-S	<b>Modesty panel</b> Anthracite-coloured coating						711

		Dim. in cm W D H	Oak black	Oak light grey titan urban grey	Pear	Laminate nano black white stone pine brick mocca		
	T 42	<b>Corner top</b> Frame chrome	110 110 73	3.703	3.780	3.968	3.757	
	T 42-1	<b>Desk pad</b> Leather black						585
	T 42-2	<b>Desk pad with sliding element</b> Leather black						1.779
	T 42-S	<b>Modesty panel</b> Anthracite-coloured coating						674
	T 43	<b>Quarter circle</b> Frame chrome	120 90 73 radius	3.680	3.771	4.078	3.733	
	T 43-1	<b>Desk pad</b> Leather black						691
	T 43-2	<b>Desk pad with sliding element</b> Leather black						1.799
	T 43-S	<b>Modesty panel</b> Anthracite-coloured coating						674
	T 45	<b>Quarter circle</b> Frame chrome	150 90 73 radius	4.110	4.240	4.630	4.133	
	T 45-1	<b>Desk pad</b> Leather black						967
	T 45-2	<b>Desk pad with sliding element</b> Leather black						2.029
	T 45-S	<b>Modesty panel</b> Anthracite-coloured coating						736

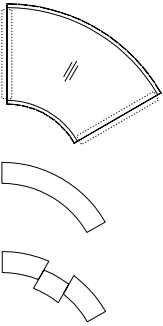
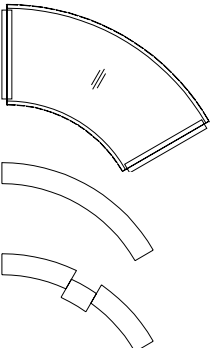
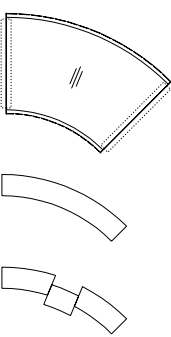
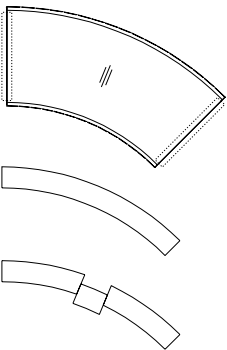
		Dim. in cm radius D H	Oak black	Oak light grey titan urban grey	Pear	Laminate nano black white stone pine brick mocca		
	T 63	<b>Sixth circle</b> Frame chrome	160 90 73	3.680	3.771	4.078	3.733	
	T 63-1	<b>Desk pad</b> Leather black						691
	T 63-2	<b>Desk pad with sliding element</b> Leather black						1.799
	T 63-S	<b>Modesty panel</b> Anthracite-coloured coating						674
	T 65	<b>Sixth circle</b> Frame chrome	210 90 73	4.110	4.240	4.630	4.133	
	T 65-1	<b>Desk pad</b> Leather black						967
	T 65-2	<b>Desk pad with sliding element</b> Leather black						2.029
	T 65-S	<b>Modesty panel</b> Anthracite-coloured coating						736
	T 83	<b>Eighth circle</b> Frame chrome	210 90 73	3.680	3.771	4.078	3.733	
	T 83-1	<b>Desk pad</b> Leather black						691
	T 83-2	<b>Desk pad with sliding element</b> Leather black						1.799
	T 83-S	<b>Modesty panel</b> Anthracite-coloured coating						674
	T 85	<b>Eighth circle</b> Frame chrome	280 90 73	4.110	4.240	4.630	4.133	
	T 85-1	<b>Desk pad</b> Leather black						967
	T 85-2	<b>Desk pad with sliding element</b> Leather black						2.029
	T 85-S	<b>Modesty panel</b> Anthracite-coloured coating						736





## Product description

### TUNE

is a modular system of conference tables. The tabletops will be combined at will to create conference solutions for each room situation.

#### Tops

The tabletops are made out of veneered high density chipboard. They are 31 mm thick and are offered in the common veneers. The veneer runs in direction to the table depth. The outside edge of the tabletop is bevelled. A straight, 13 mm high thick veneer edge shapes a bevel angle of 28°. Changes in veneer pattern and size of tops are available on special request. The required frames are included in the price of the tops.

#### FENIX NTM\*

Fenix NTM is a nanotech material of the company Arpa Industriale, which we offer under the label Laminate nano in our collection.

#### Frames

The tabletops are supported by elegantly curved frames which taper themselves downward in an angle of about 10°. The frames are normally ranged at the joint of the tops. They consist of a 90 mm wide steel band and are offered in the surface chrome-plated. An adjustable screw, installed concealed, allows to level uneven floors. The standard height of the tables is 73 cm.

#### Desk pad / Function strip

Matching to all tabletops a pad is offered, which is 19 cm deep and finished in black leather. It serves as a table mat for bottles and glasses and can be opened for the access to the conduit (via power strip) or to a utensils tray via a sliding element.

Sliding element, power strip and utensils tray have to be ordered separately. The desk pad can be lifted to clean the tabletop.

#### Traverse System / horizontal cabling

Aluminium traverses, 80 mm thick, connect the frames and grant stability. A pivot joint out of aluminium diecast enables to adjust the traverses to all desired table shapes. Cables are routed using cable loops (Velcro) attached parallel to the frames. All power strips are secured in powder-coated steel trays.

#### Modesty panel

The modesty panels (height 32 cm) are made out of sheet steel and have an anthracite-coloured coating. They are fixed beneath the tabletop and bear with their ends on the inside of the frames. Analogical to the frames the modesty panes are bent in an angle of 10° to the inside.

#### Power box (can be opened to 1 side)

The power box (T 72) is leveled into the tabletop and finished to match the tabletop. A 17 mm wide cut-out serves as cable outlet. The power box allows access to the T 71 utensil tray or to the power strips. Utensils tray and power strips must be ordered separately. Power strips with various configurations must be selected and completed from page 93 on.

#### Power box (can be opened to 2 sides)

The power box (T 92) is leveled into the tabletop and finished to match the tabletop. A 17 mm wide cut-out each serves as cable outlet. The power box does not yet contain a power strip. Power strips with various configurations must be selected and completed from page 93 on.

The power strips are fixed in the cable tray under the sliding element or the power box. All power strips come fitted with a GST18 power input/output. The length of cable is 2,90 m. Cables for connecting two or more power strips, as well as other options for outfitting power strips, are available upon request.

#### Vertical cabling

The two-part vertical cabling is attached magnetically to the inner side of the frame. The cable-running conduit is coated in black colour and is covered by a blind, carried out in the finish of the frames.

T 42 Corner top  
T 42-1 Desk pad

T 06 End top  
T 06-2 Desk pad with sliding element

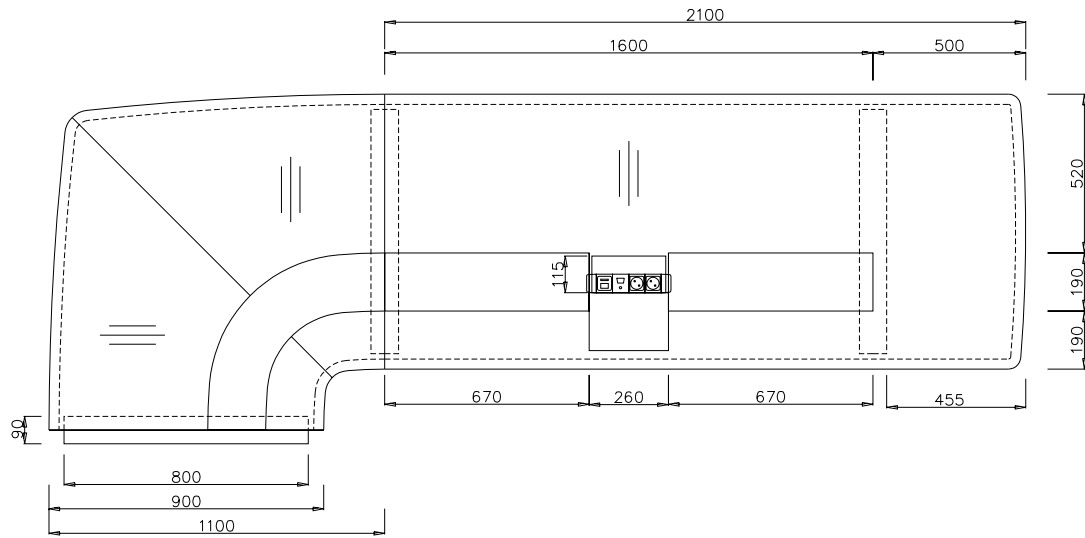

T 31 Inner top  
T 31-3 Desk pad with 2 sliding elements or. Power box T 72 / T 92

T 33 End top  
T 33-3 Desk pad with 2 sliding elements or. Power box T 72 / T 92

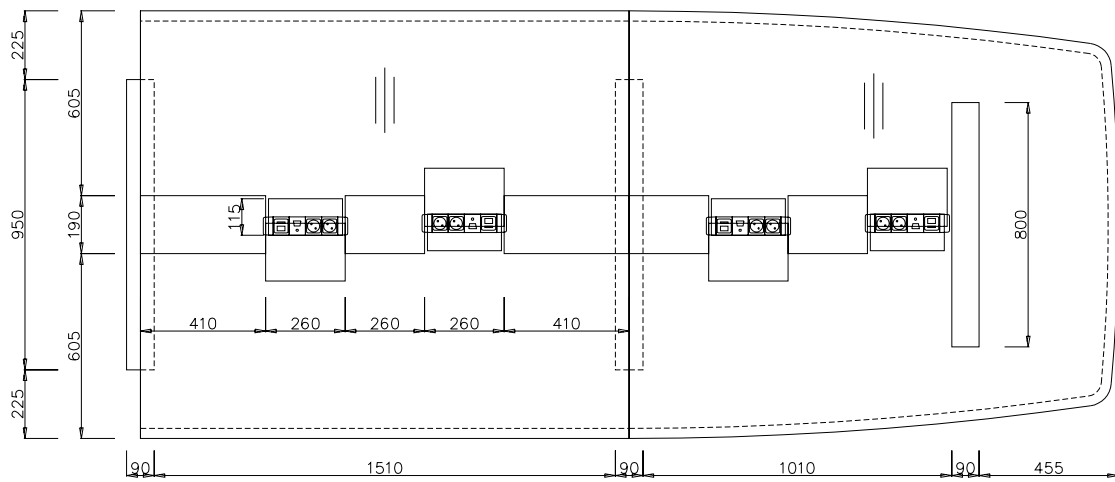

## Prices of example units

Scale 1:100

A

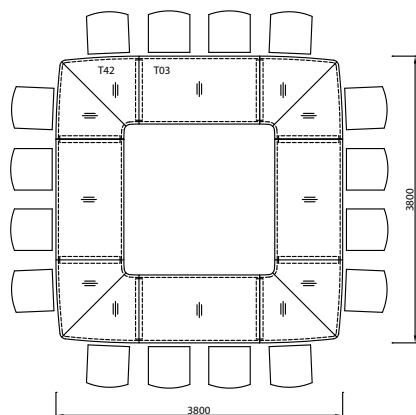

Euro 27.556 \*

B

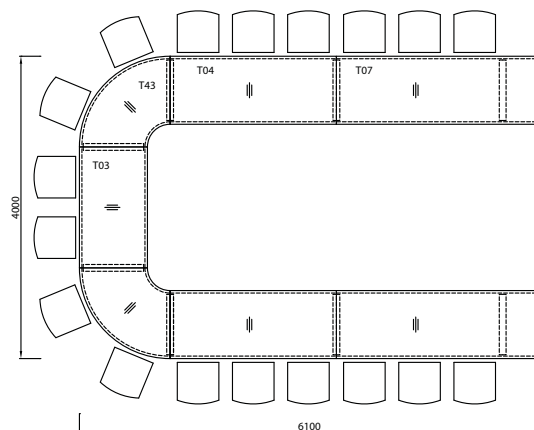

Euro 26.701 \*

C

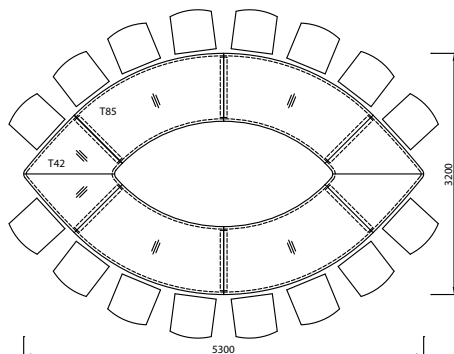

Euro 24.520 \*

D

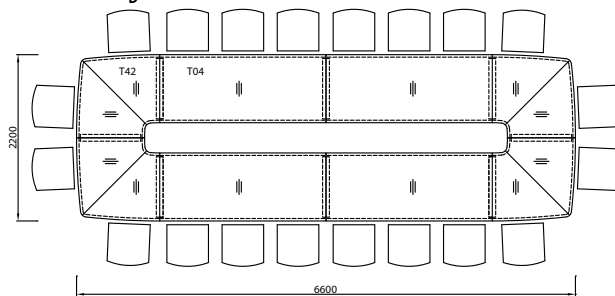

Euro 28.808 \*

E

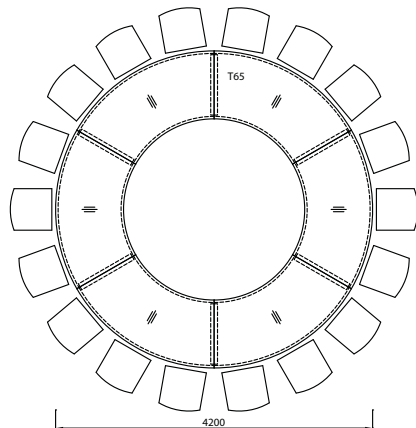

Euro 25.440 \*

F

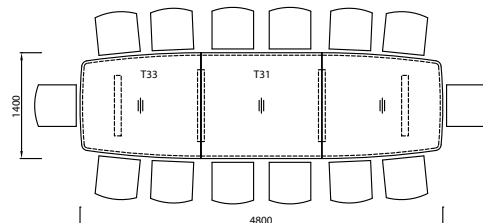





Euro 14.465 \*





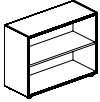

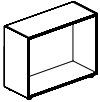
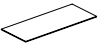
# Site



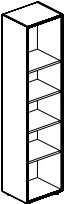

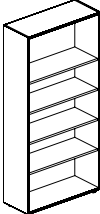
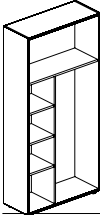
		Dim. in cm W D H	Laminate anthracite	Oak black	Oak light grey titan urban grey	Pear	Lacquer aluminium silver	
	E 01	<b>Unit</b> open unit or door unit lh/rh all laminate anthracite laminate anthracite/sides veneer or lacquer all veneer	577	1.183 1.755	1.208 1.775	1.495 2.405	1.273	
		shelf in addition	63	240	256	332		
	E 02	<b>Door lh/rh</b> Handle chrome bright or aluminium anodised matt		423	440	614	496	
		with lock		537	554	727	610	
	E 03	<b>Unit</b> open unit or door unit all laminate anthracite laminate anthracite/sides veneer or lacquer all veneer	678	1.293 2.072	1.319 2.155	1.609 3.061	1.380	
		shelf in addition	80	318	335	501		
	E 04	<b>Pair of doors</b> Handles chrome bright or aluminium anodised matt		847	877	1.230	995	
		with lock		963	998	1.348	1.115	
	E 05	<b>Unit</b> for filing unit all laminate anthracite laminate anthracite/sides veneer or lacquer all veneer	625	1.235 1.778	1.260 1.845	1.549 2.581	1.322	
	E 06	<b>Filing front</b> Handles chrome bright or aluminium anodised matt Wall fastening required.		1.530	1.571	1.920	1.702	
		with central locking		1.615	1.653	2.005	1.787	
	E 19	<b>Covering panel for E 01 - E 05</b>	run. m 41	184	420	438	612	415

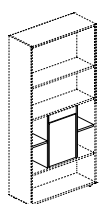
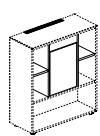
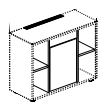

		Dim. in cm W D H	Laminate anthracite	Oak black	Oak light grey titan urban grey	Pear	Lacquer aluminium silver	
	E 41	<b>Unit</b> open unit or door unit lh/rh all laminate anthracite laminate anthracite/sides veneer or lacquer all veneer	1.039	2.077 3.422	2.126 3.557	2.939 4.993	2.156	
		shelf in addition	63	240	256	332		
	E 42	<b>Door lh/rh</b> Handle chrome bright or aluminium anodised matt		808	840	1.335	916	
		with lock		961	991	1.482	1.072	
	E 43	<b>Unit</b> open unit or door unit all laminate anthracite laminate anthracite/sides veneer or lacquer all veneer	1.221	2.261 4.136	2.310 4.307	3.124 6.586	2.338	
		shelf in addition	80	318	335	501		
	E 45	<b>Unit</b> with wardrobe for door unit all laminate anthracite laminate anthracite/sides veneer or lacquer all veneer	1.405	2.476 4.349	2.524 4.523	3.338 6.790	2.553	
	E 44	<b>Pair of doors</b> Handles chrome bright or aluminium anodised matt		1.609	1.670	2.658	1.824	
		with lock		1.758	1.821	2.811	1.981	
	E 90	<b>Built-in fridge</b> for unit 100 cm wide, 5 folder heights Fridge 28 litre. Finish grey. Door hinged rh. Ventilation by a blank in the plinth.	3.041	3.618	3.720	4.012		
	E 91	<b>Built-in fridge</b> for unit 100 cm wide, 3 folder heights Fridge 28 litre. Finish grey. Door hinged rh. Ventilation by a blank in the plinth and a ventilation grille in the covering panel.	3.041	3.618	3.720	4.012		
	E 92	<b>Built-in fridge</b> for unit 100 cm wide, 2 folder heights Fridge 28 litre. Finish grey. Door hinged rh. Ventilation by a blank in the plinth and a ventilation grille in the covering panel.	3.041	3.618	3.720	4.012		

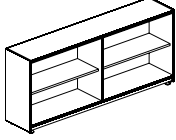
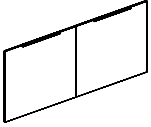
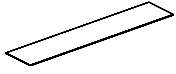
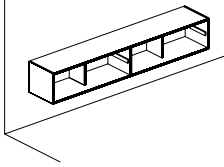
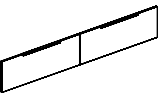
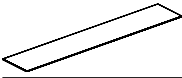
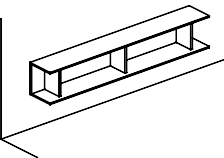

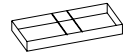
		Dim. in cm W D H	Laminate anthracite	Oak black	Oak light grey titan urban grey	Pear	Lacquer aluminium silver	
	E 61 <b>Unit</b> sliding door unit all laminate anthracite laminate anthracite/sides veneer or lacquer all veneer  shelf in addition	200 43 87,5	3.039	3.663 4.997	3.693 5.135	4.027 6.848	3.563	
	E 62 <b>Pair of sliding doors</b> Handles chrome bright or aluminium anodised matt with 2 locks			1.456	1.521	2.306	1.179	
	E 69 <b>Covering panel for E 61</b>	200 41	237	639	664	1.017	484	
	E 71 <b>Unit</b> Credenza wall mounted, for flaps all laminate anthracite laminate anthracite/sides veneer or lacquer all veneer	220 33 37,2	1.805	2.485 3.931	2.507 4.043	2.647 5.152	2.360	
	E 72 <b>Pair of flaps</b> Handles chrome bright or aluminium anodised matt with 2 locks			1.138	1.183	1.567	1.028	
	E 79 <b>Covering panel for E 71</b>	220 41	259	664	694	1.077	508	
	E 74 <b>Open credenza, wall mounted</b>	220 33 37,2		2.113	2.186	3.114	1.839	
	E 75 <b>Set of dividers (for open credenza)</b>			851	880	969	747	
	E 85 <b>Filing frame</b> for unit 100 cm wide Wall fastening of the units required.		438	438	438	438	438	
	<b>Reduction width</b> Unit (open unit or door unit, without shelf) Shelf Door Pair of doors		223 42 200 288	223 42 200 288	223 42 200 288	223 42 200 288	200 288	
	<b>Reduction height</b> Unit (open unit or door unit) Door Pair of doors		222 136 181	222 136 181	222 136 181	222 136 181	136 181	

## Product description

### SITE

is a modular storage system, consisting of open units and closed units with doors. The elements can be combined freely. Corpuses are offered in two widths and three heights. A sideboard with flaps and an open, wall-mounted shelf are available as wall-mounted furniture. A sideboard with flush sliding doors and a media element round off the range. Units, front panels and covering panels can be chosen and combined in various finishes. The handle profiles are available in either aluminium anodised matt or chrome bright.

### Raster and construction

Units are 43 cm deep (inclusive front panels) and either 50 cm or 100 cm wide. The raster heights are 77,3 cm (2 folder heights), 114,5 cm (3 folder heights), 210,0 cm (5 folder heights). Leveling feet (3 cm) as well as an imperative covering panel (0,8 cm) at credenza and highboard elements are contained in these measures.

Single units are the wall mounted credenza E 71/72 with a width of 220 cm and the sliding door unit E 61/62 with a width of 200 cm. Both single units have divergent special heights (see articles). The lower unit of the media element E 51 has a height of 87.5 cm and is matched in height to the sliding door unit.

The open, wall mounted credenza E 74 can only be ordered together with the set of dividers E 75.

### Units

All units have a grid drilling inside and are offered in three alternatives:

- completely laminate anthracite
- laminate anthracite, sides veneer or lacquer
- completely veneer.

Leveling feet have a black-/gray-coloured powder coating.

### Front panels

Surface finishes of the front panels are available in veneer or lacquer. They are lockable on request.

### Interior equipment

Filing frames (RAL 9006) can be mounted as front pull-outs or behind doors.

### Media element

Flat screens with a diameter from 58 to 70 inches can be attached to the E 51 media element. Optionally, sound bar, camera and microphone for video conferencing can be added. The element contains a monitor holder with a load capacity of up to 60 kg for screens from VESA 200/200 to 600/400. The element has to be fastened to the wall to prevent from falling over. A wall socket and data connections at the rear / bottom of the wall are required on site for installation. Ventilation openings are built-in.

There is a flap door storage compartment in the lower unit of the media element. It may be used to store accessories such as keyboard, mouse, remote control, ... . There is a main switch and a USB 3.0 data socket for presentations with USB flash drives. The corpus, with a total depth of 22 cm, offers space inside for hardware equipment and a power strip with 4 x power.

### Sliding doors

The sliding door unit E 61/62 has pre-front sliding doors to be opened mutually. They are moved forwards and following sideways above the other front panel.

### Assembly

Storage elements are delivered completely assembled and have only to be placed flush in line and screwed together on site. Afterwards the continuous upper covering panel (maximum length 250 cm = 2,5 width grids) is mounted at credenza and highboard elements. Units with filing frames have to be fastened to the wall by customer to prevent from falling over.

The sliding door unit is delivered ex works with a preassembled and adjusted fitting. The element has to be set up exactly and must be fastened to the wall by customer – this is precondition for the faultless function of the sliding doors. Afterwards the sliding doors are mounted. For this please follow the notes in our assembly instruction.

The wall mounted credenza E 71/72 can only be installed to a load-bearing wall.

Please, already observe the assembly requirements in the field of planning and ask about the constitution and load capacity of the relevant wall. Reinforcements in the wall construction are required for dry and stud walls.

The assembly material (screws and plugs) has to be harmonized to the relevant wall. Therefore it cannot be enclosed ex works.

- E 51 Media element
- E 52 Flap door front
- E 59 Covering panel for E 51

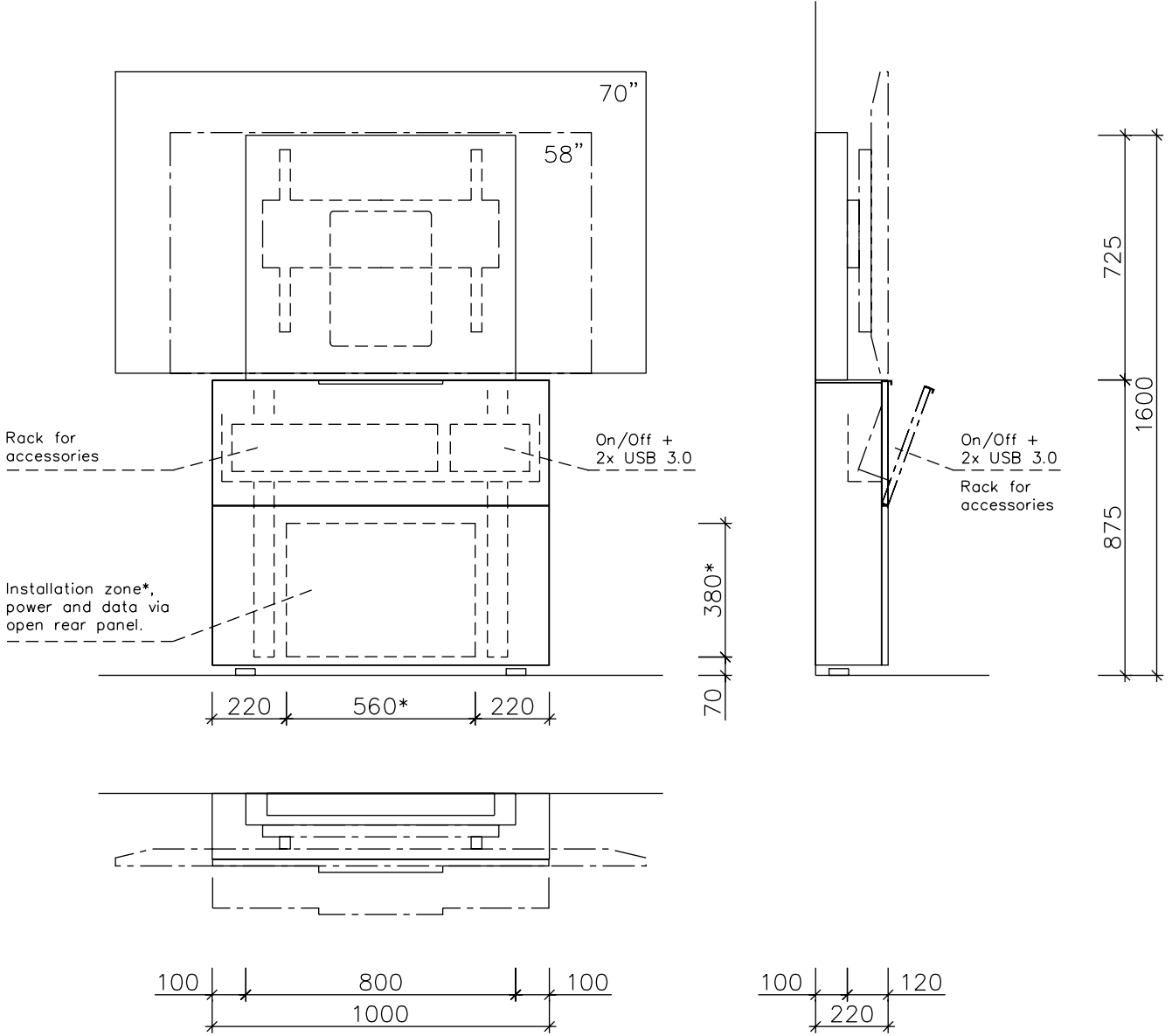





		Dim. in cm								
		W	D	H						
	0Z99 0000	<b>Built-in inductive charger</b> Visible installation			Ø 8	405				

## Product description

### POWER STRIP

Power strips made of high-quality black plastic material. For to be used in power boxes, sliding leather desk pads and many other articles specified in the price list.

For some power strips and the X 92 and X 93 built-in desk units (SPARK program), custom power strips with more than four sockets are available upon request.

All articles have 230V input and output (plug + socket GST 18/3) for connecting with main cables and / or connecting cables.

## Delivery and Payment Conditions for International Sales

These conditions form an integral part of all our offers and contracts, also in current or future business relationships. They take precedence over any conflicting contractual documents or terms and conditions of the customer. All deviating provisions must be agreed upon in writing and signed by both parties in order to be valid.

If we use terms such as EXW, DDP etc. for an order, they shall have the meaning assigned to INCOTERMS 2020.

### 1. Offers, contracts

Our offers are in general non-binding. Contracts become valid with our order confirmation. Changes and additions must be made in writing, verbal agreements require our written confirmation. If an order that has already been processed and confirmed is changed, we reserve the right to charge EUR 400.00 (retail price) for the additional cost of the change.

We reserve the right to make minor technical, constructional and formal alterations of our products. With natural materials, such as wood and veneer, the customer accepts that any descriptions, illustrations or samples can only be examples due to the natural and/or typical variations of wood in structure, colour and quality. Customers are obliged to accept goods in the case of products manufactured on a commission basis and in the case of those produced in specially-ordered shades or sizes. Altering or cancelling orders such as these is not permitted.

### 2. Delivery

Delivery dates which are indicated in our order confirmations are dates, when orders are ready and prepared for collection or shipment. Delivery dates are approximate, fixed delivery dates has to be confirmed in writing. Goods can be shipped in time, when the customer has fulfilled his contractual obligations with respect to previous contracts. The dispatch can only occur promptly provided that we have been provided with all the necessary information for its manufacture on time. Delays in the receipt of colour samples and measurements, etc. automatically result in an extension of the dispatch deadline.

Our failure to meet delivery dates will only entitle the customer to assert remedies after a reasonable additional time period of at least 21 working days has expired. In the event of delays that are due to force majeure, industrial action, official acts and business interruptions through no fault of our own, the delivery period will be appropriately extended.

The customer will be in default of acceptance and have to pay reasonable storage costs if he fails to collect or take delivery of the goods within 2 weeks after notice has been given that the goods are ready for shipment, we have the right to invoice the customer for the goods and demand storage fee of 0,5 % of the order value per week, limited to a maximum of 15 %.

### 3. Minimum quantity surcharge

If the quantity ordered by the customer results in an order value below the retail price of EUR 1.000,00, we are entitled to charge an additional price of EUR 100,00 (retail price) due to the increased logistics efforts.

### 4. Passing of the risk

Risk is passed to the client as soon as the goods have been handed over to the carrier. This is also valid in the event that a freight paid delivery has been agreed. If the order is being collected, risk is passed at the goods' allocation.

### 5. Payment

Our invoices are denominated, and have to be paid, in Euros; currency risks are borne by the customer. Making deductions is not allowed. If the time allowed for payment is exceeded, we may charge 8 % interest, subject to further damage. All payments must be received such that the amount is credited to our bank account by the due date.

Upon default of payment, we may combine all quantities of goods yet to be supplied in a single delivery and make such delivery contingent upon the payment of all invoices due and on an advance payment on the invoices yet to be paid. We may further demand immediate payment of all receivables outstanding at the time of default, for whatever legal reasons and, in particular, under whatever contract, and terminate any agreements concerning payment in installments. Until all outstanding receivables have been paid, we have the right to retain any goods not yet supplied or other services yet to be provided.

### 6. Retention of Title

The goods remain our property until the customer has paid all claims arising from the business relationship, including future claims and, in particular, any current account balance, or until all bills of exchange and checks that were delivered in payment have been honored.

Furthermore, the goods remain our property if and to the extent that we assume an obligation to third parties on behalf of the customer until such obligation ceases to exist.

The customer may sell the goods only in the ordinary course of business; he is not authorized to pledge the goods or transfer them by way of security. If the goods are sold or otherwise made available to third parties, the customer hereby assigns to us all financial and other claims accruing to him.

### 7. Warranty for Defects

The customer must, without undue delay, carry out a thorough examination of the products supplied. For this purpose, he must examine the entire delivery. The examination must, in particular, include a visual examination of the surface. Any defects must be reported to us without undue delay, but in any case within 4 working days after delivery. If an examination does not occur or the defects are not reported, the customer will forfeit all his warranty claims. If we bear the transport risk in particular cases, any damages in transit must be confirmed by the carrier upon delivery. Warranty claims for defects become time-barred within 2 years of the delivery (limitation period).

We will primarily carry out the subsequent performance – where appropriate, with the assistance of third parties – at the customer's place of business, even if we are aware of the final destination of the consignment, or reduce the purchase price appropriately.

### 8. Damage to goods in transit

Damages in transit must be noted on the delivery note immediately upon delivery for legal insurance reasons. Details of latent damages in transit must be made known to us or to the forwarding agency in writing within 7 days of the goods being received. The client or recipient is liable to prove that the damages were caused by our carrier. All claims shall lapse in the event of the acknowledgment of the delivery note without reservation, further transportation of the goods by the client and at the latest 7 days after the receipt of the goods.

### 9. Liability

Damage claims against us arise only in the event that damage was caused by us or one of our vicarious agents wilfully or as a result of gross negligence on our behalf. In principle, damage claims against us are excluded. In the event that the client withdraws from their assigned commission or fails to fulfil the terms of the contract, we reserve the right to demand 30% of the order amount in damages. We reserve the right to demand demonstrably increased damages.

### 10. Miscellaneous

This agreement shall be governed by German law, with the exception of the law applicable to general terms and conditions. In this respect, the laws that apply in the customer's jurisdiction shall apply. The place of performance for the delivery and payment is 71034 Böblingen, Germany. The place of jurisdiction for all disputes is Stuttgart, Germany. Customer's rights arising from this contract are non-transferable.



Pear natural

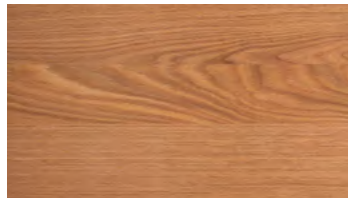

Solid oak, oiled

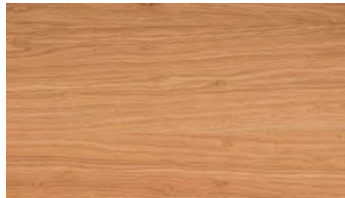

Oak matt

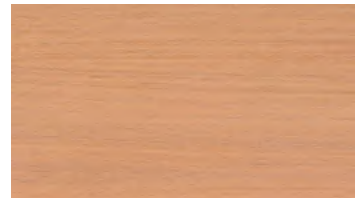

Oak light

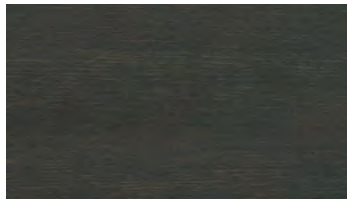

Oak grey titan

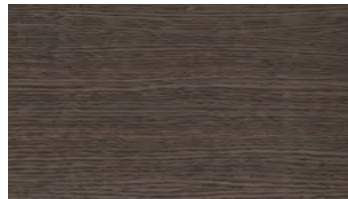

Oak urban grey

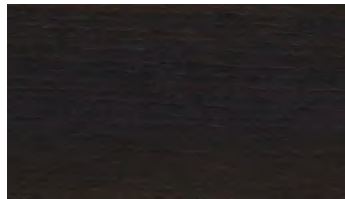

Oak smoked

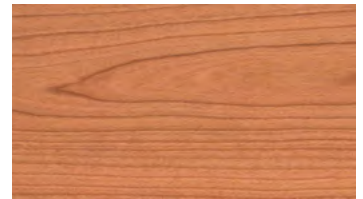

Am. Cherry natural



Am. Walnut natural

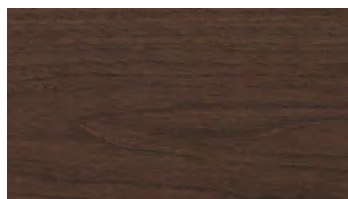

Walnut tobacco

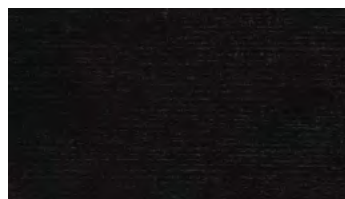

Oak black



Laminate nano white / Lacquer white



Laminat nano stone / Lacquer stone



Laminat nano pine / Lacquer pine

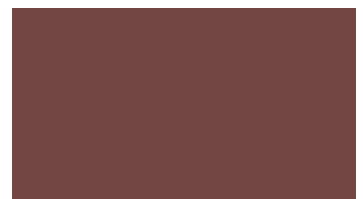

Laminate nano brick / Lacquer brick



Laminat nano mocca / Lacquer mocca



Laminate nano black / Lacquer black

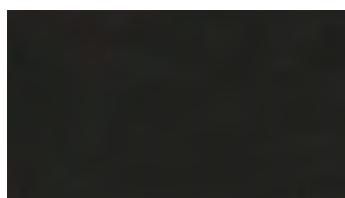

Lacquer black metallic



Lacquer brown metallic



Lacquer anthracite

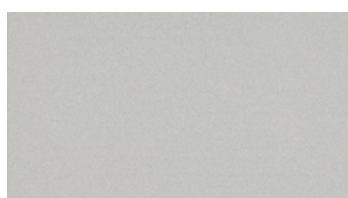

Lacquer aluminium silver



Laminate uni white



Laminate uni stone

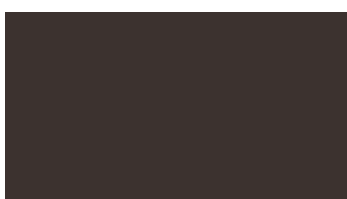

Laminate uni mocca



Laminate uni black



Laminate uni grey



Laminate anthracite



Wilhelm Renz GmbH + Co. KG  
Hanns-Klemm-Straße 35  
71034 Böblingen  
Germany

T +49 (0)7031.21880  
[info@renz.de](mailto:info@renz.de)

[www.renz.de](http://www.renz.de)